

# Assembly Instructions

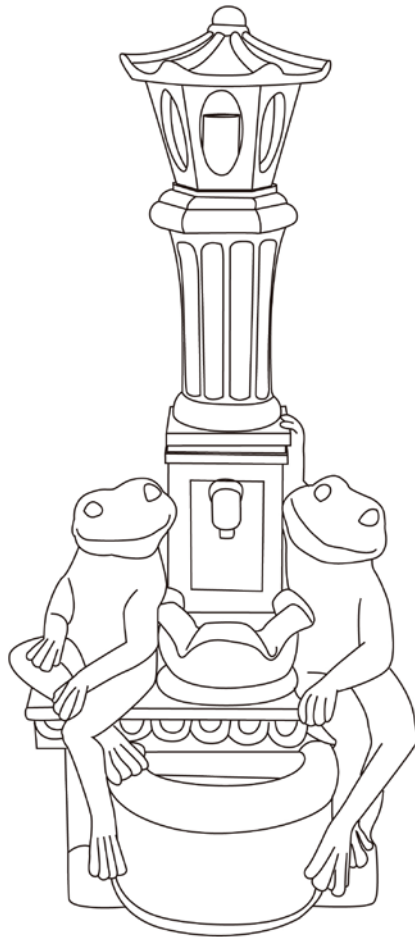



**Caution : You must read this before you proceed**



**WARNING**

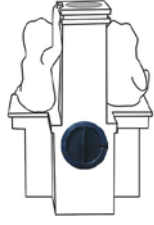

**Choose an appropriate location for the fountain.**  
**Excessive weight or pressure on any of the fountain sections may cause it to fall. Keep pets, children, or anyone from sitting, leaning, or climbing on any components of the fountain.**  
**While fountain is designed to operate as splash free as possible, some water splashing out of the fountain is inevitable. Place the fountain in a location where any splashing will not cause damage.**  
**Keep this manual for future reference.**  
**Take out all the package parts from the carton, follow assembly the fountain as below steps**



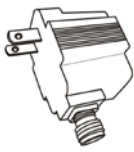

## Parts List

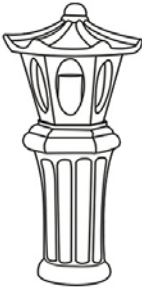
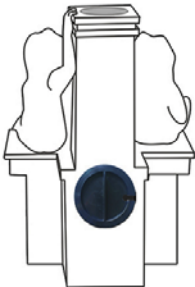
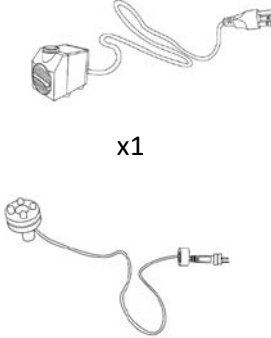
Label	Picture	Description	QTY
A		Fountain Body	1
B		Fountain Base with LED light and 6 LED lights	1
C		Pump	1
D		6 LED Light	1
E		Splitter	1

F		Transformer	1
---	---	-------------	---

## Assembly Preparation

<p><b>Before Beginning Assembly:</b></p>	 x1	 x1	 x1	 x1	 x1
--	---	---	--	---	---

- 
• Read instructions, cover to cover-
- 
• Have 2 adults on hand for assembly-
- 
• Do not assemble on flooring or carpet-
- 
• Assemble on a clean non-marring surface (packing foam)-
- 
• Save all packaging until finished-

## Assembly Steps

This Fountain has multiple parts and may require up to some minutes to assemble. Please read through the instructions below to familiarise yourself with the parts and steps before assembly.

## Step 1

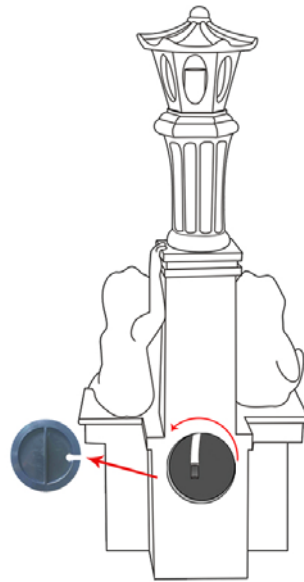

Attach Fountain Body(A) with Fountain Base(B). And place it on a level surface away from areas where it is likely to get colgged with leaves and make sure that the cable will reach the socket and open the back door(anticlockwise).

## Step 2

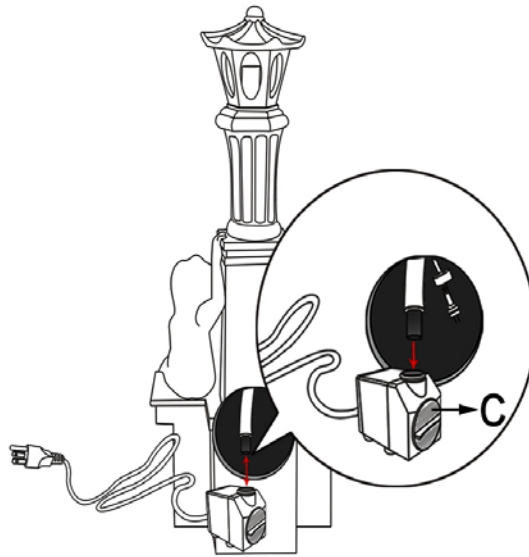

Insert water pipe into the Pump(C).

Step 3

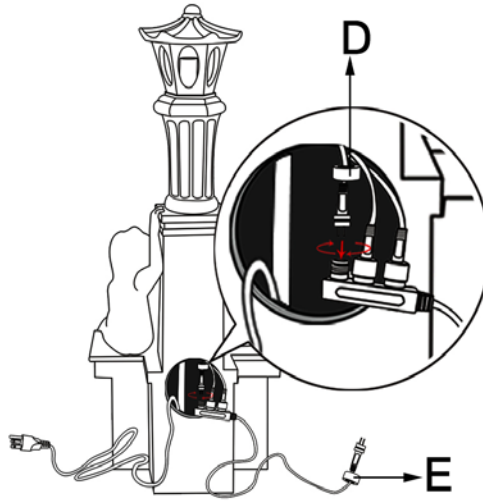

Connect and insert the 6 LED Light(D) into Splitter(E).

Step 4

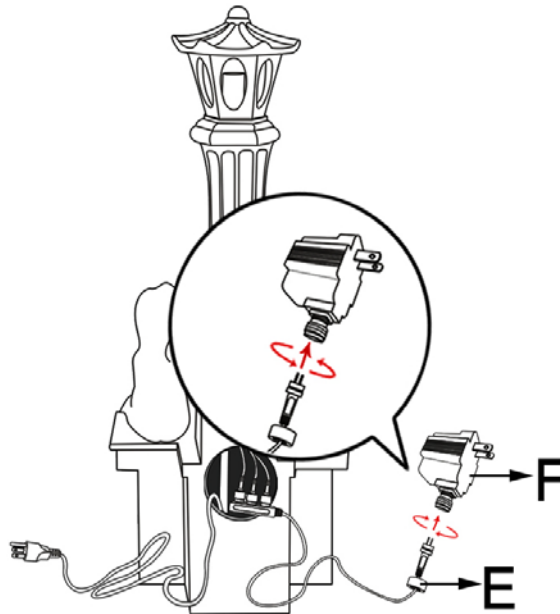

Connect the end of Splitter(E) into Transformer( F).

## Step 5

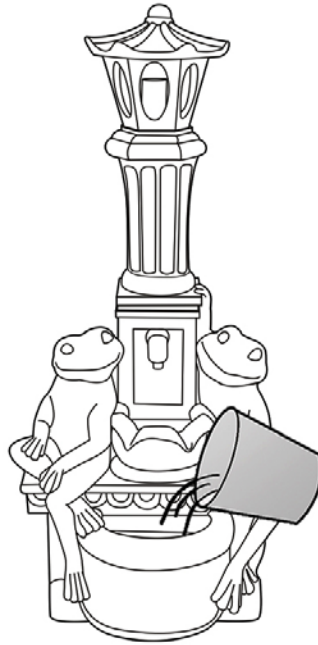

Fill the Fountain with clean water.

## Step 6

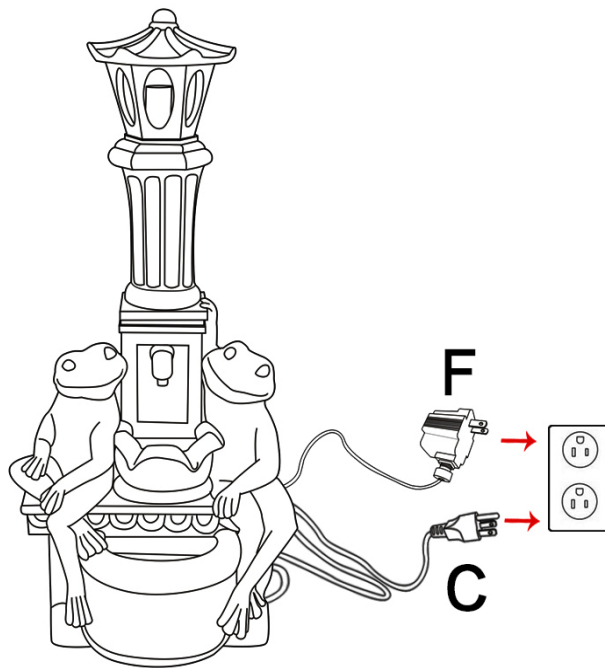

Plug the Pump(C) and Transformer(F) in the socket, then the water will start to flow in minutes.

**Attention:** Always make sure the water can submerge the pump completely to work properly to prevent the pump damage.

**Troubleshooting:**



















## Troubleshooting:

### Turn off the power before you check following!

If pump does not run, or lights not on:

- (1) Check the circuit breaker, try another outlet.
- (2) Check the water level in the fountain. Running the pump without sufficient water can damage the pump.
- (3) Check the setting of the flow control on the pump and adjust the flow.
- (4) Check the pump discharge and intake for dirt and debris.
- (5) The pump might be "air locked", plug and unplug the pump.
- (6) Check and reconnect all the cords and try again.

## Care & Maintenance

-   ● Do not put hot items directly on furniture surface
  -   ● Do not clean furniture with harsh cleansers or polish.
  -   ● To obtain the longest lifespan of your outdoor products, minimizing exposure to direct sunlight is recommended.
  -   ● Children should not climb or jump on the furniture.
  -   ● Do not write on furniture without a padded barrier to protect the surface.
  -   ● To obtain the longest lifespan of your outdoor products, avoid extended and lengthy exposure to rain, snow, and direct sunshine. Whenever possible cover the product and /or place under patio or awnings.
  -   ● Not for commercial use. For residential use only .
  -   ● Stains may be removed with mild soap solution and damp cloth.
- 
-   ● Dust and pick-up spills using a clean, non-colored, lint-free cloth .