

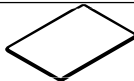









ASSEMBLY INSTRUCTION





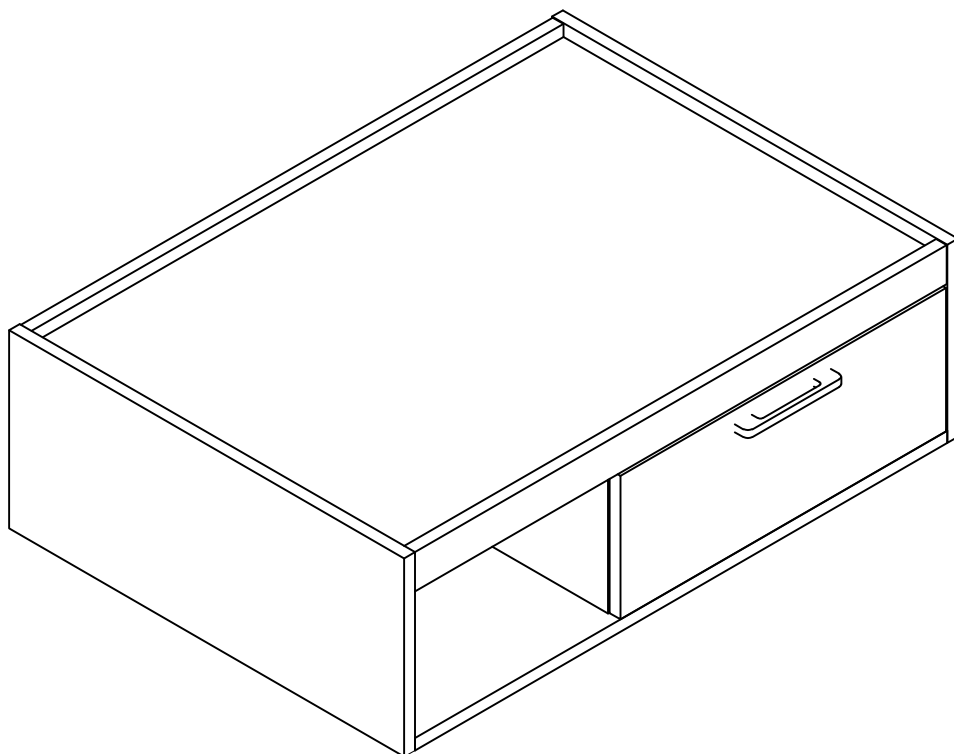
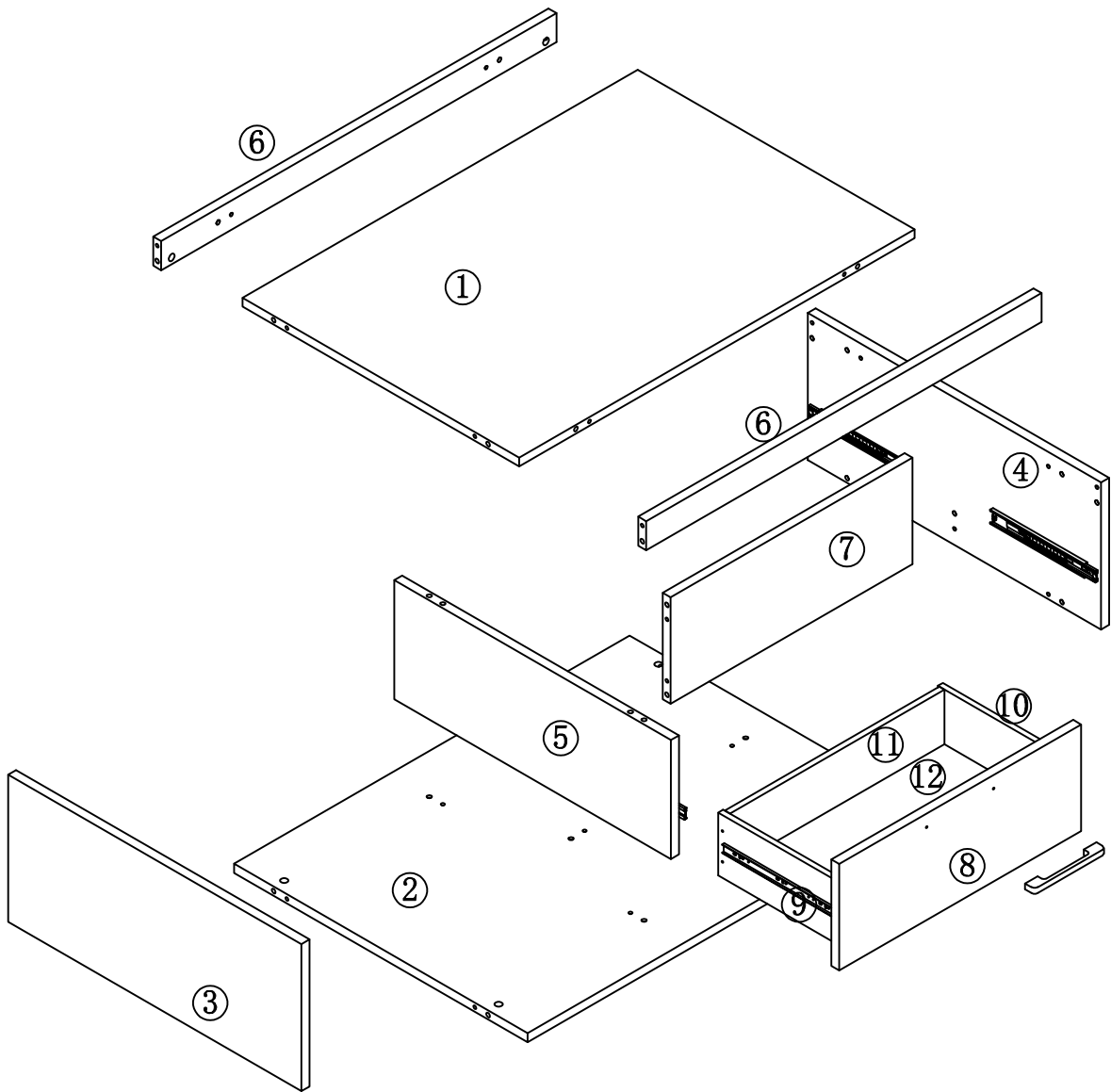

Thank you for purchasing the quality product. Be sure to check all packing material carefully for small parts which may have come loose inside the carton during shipment. Separate, Identify and count all parts and metal hardware. Compare with all parts listed to be sure all parts are present. If any part(s) are missing or damaged, please contact your local furniture dealer. For efficient and speedy service, please indicate the model number and code letter of part(s) needed.

****Do not fully tighten screws until fully assembled****

| COMPONENT PARTS | | |
|-----------------|--|-----------|
| DESCRIPTION | PART NAME | QTY (PCS) |
| ① | 947x666x18mm  | 1 |
| ② | 947x700x16mm  | 1 |
| ③/④ | 700x303x16mm  | 2 |
| ⑤ | 666x250x16mm  | 1 |
| ⑥ | 947x61x16mm  | 2 |
| ⑦ | 564x250x16mm  | 1 |
| ⑧ | 576x222x16mm  | 1 |
| ⑨/⑩ | 300x130x12mm  | 2 |
| ⑪ | 514x130x12mm  | 1 |
| ⑫ | 524x294x5mm  | 1 |

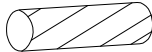

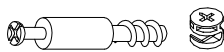
HARDWARE REQUIRED

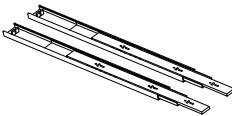
| | | | |
|---|---|-------------|-------|
| Ⓐ |  | L=42mm | 28pcs |
| Ⓑ |  | Ø15*13.5 | 28pcs |
| Ⓒ |  | Ø8*30 | 28pcs |
| Ⓓ |  | M3*12 | 8pcs |
| Ⓔ |  | M4*30 | 4pcs |
| Ⓕ |  | / | 4set |
| Ⓖ |  | M6H34 Ø 37 | 6pcs |
| Ⓗ |  | 169*23*11.5 | 1set |
| Ⓘ |  | 250mm | 1pa |

Attention

***Some number parts listed on the instruction sheet may not be in parts bag as they may be assembled. Carefully check parts and packing materials prior to ordering replacements. ***

How to assemble :

STEP 1

①



M3*12

4pcs

①

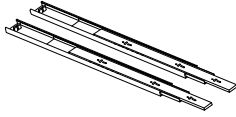

250mm

1pa

PUSH DOWN LEVER
& PULL APART

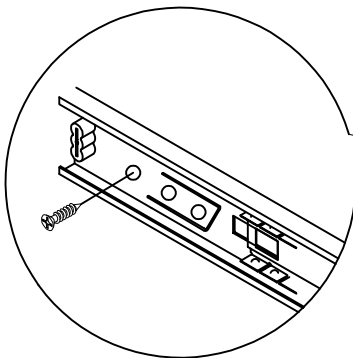
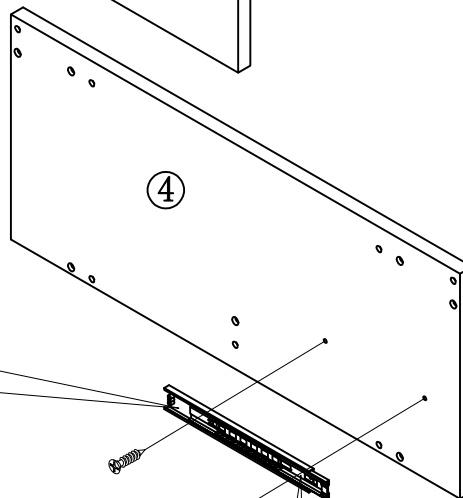
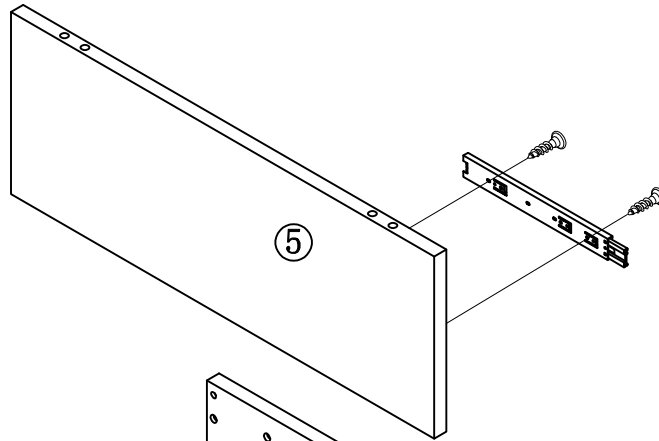
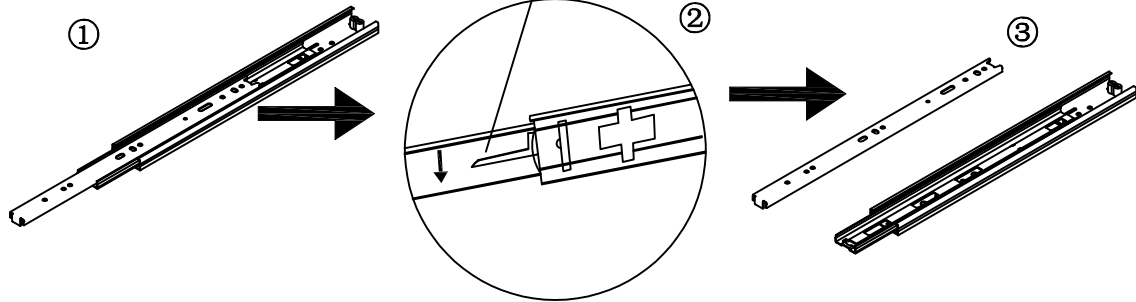

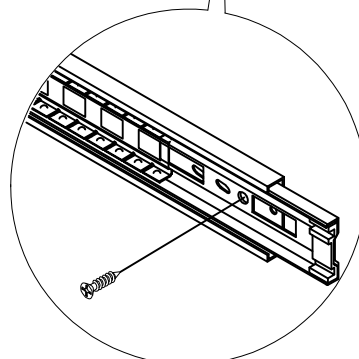

the last hole



the second hole

How to assemble :

STEP 2

- (A)  L=42mm 6pcs
- (B)  $\phi 15 \times 13.5$ 6pcs
- (C)  $\phi 8 \times 30$ 6pcs

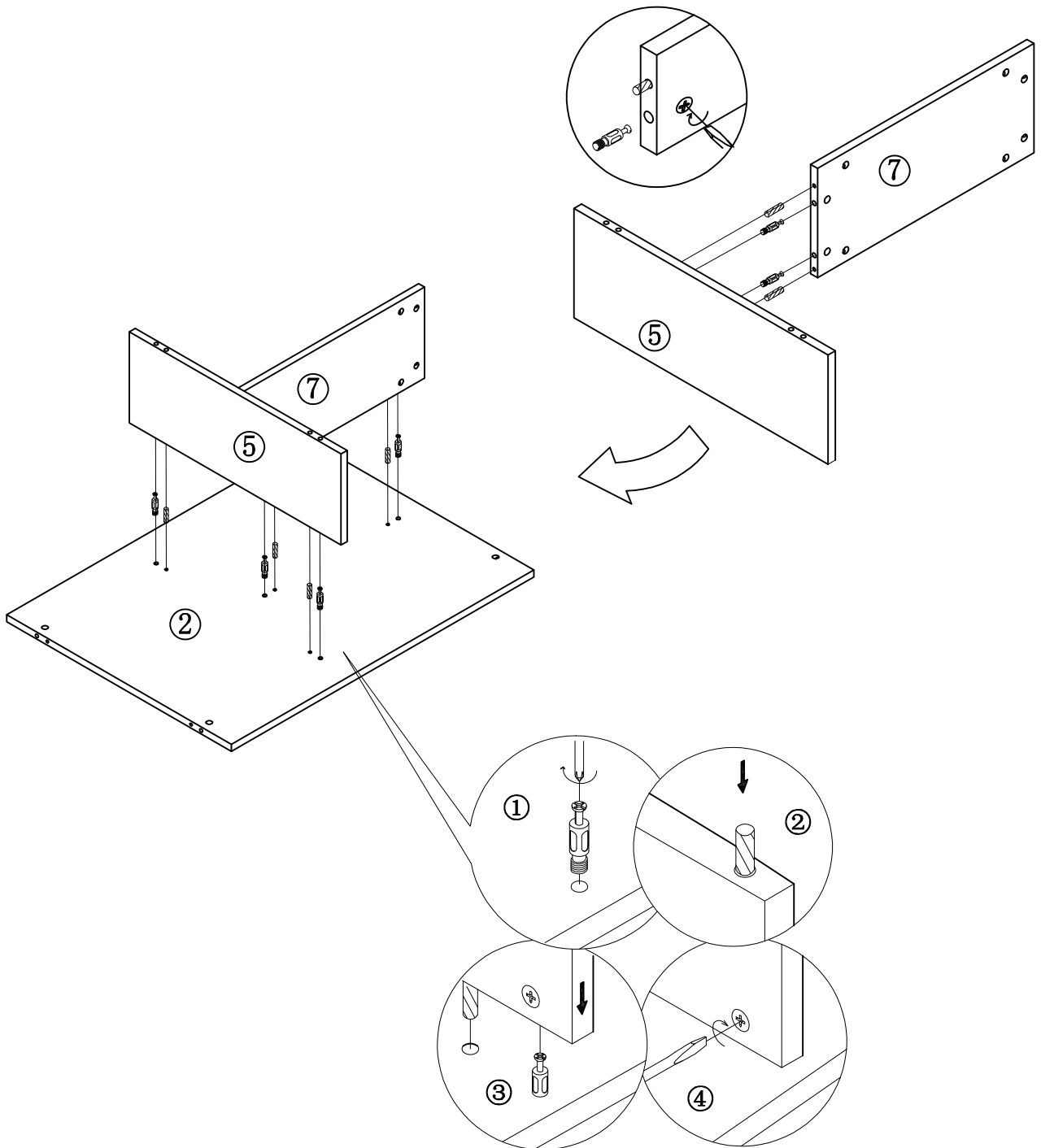

How to assemble :

STEP 3

Ⓐ  L=42mm 8pcs

Ⓑ  $\varnothing 15 \times 13.5$ 8pcs

Ⓒ  $\varnothing 8 \times 30$ 8pcs

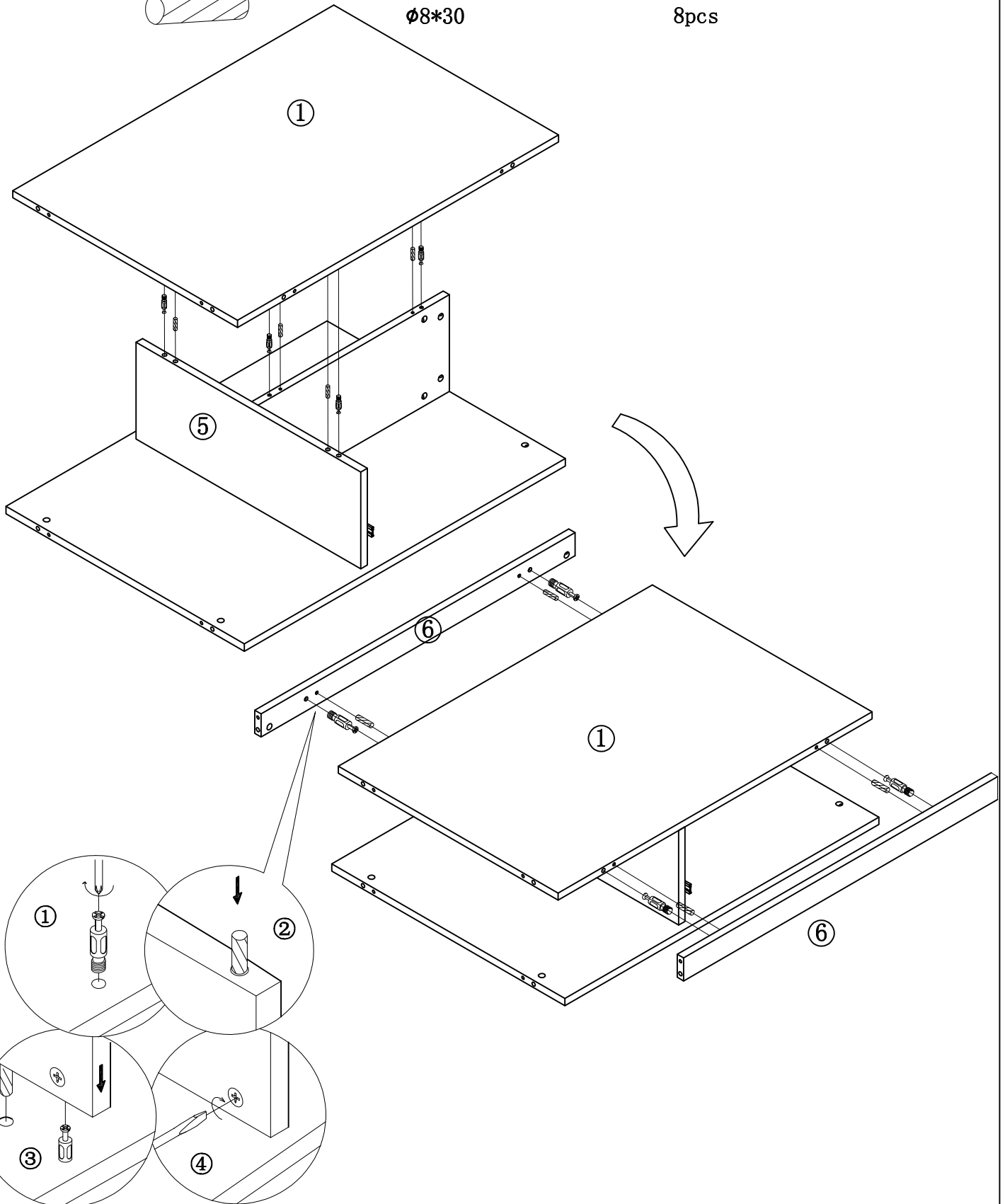

How to assemble :

STEP 4

Ⓐ  L=42mm 14pcs

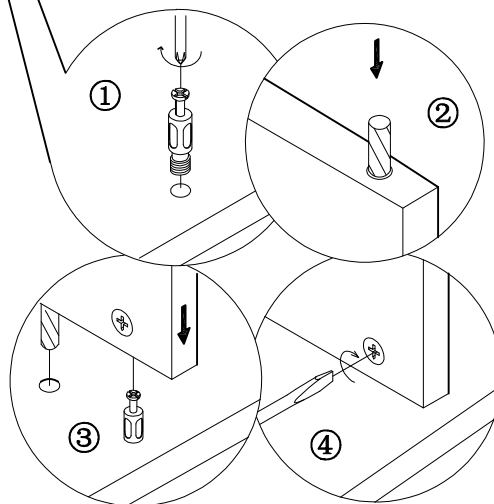
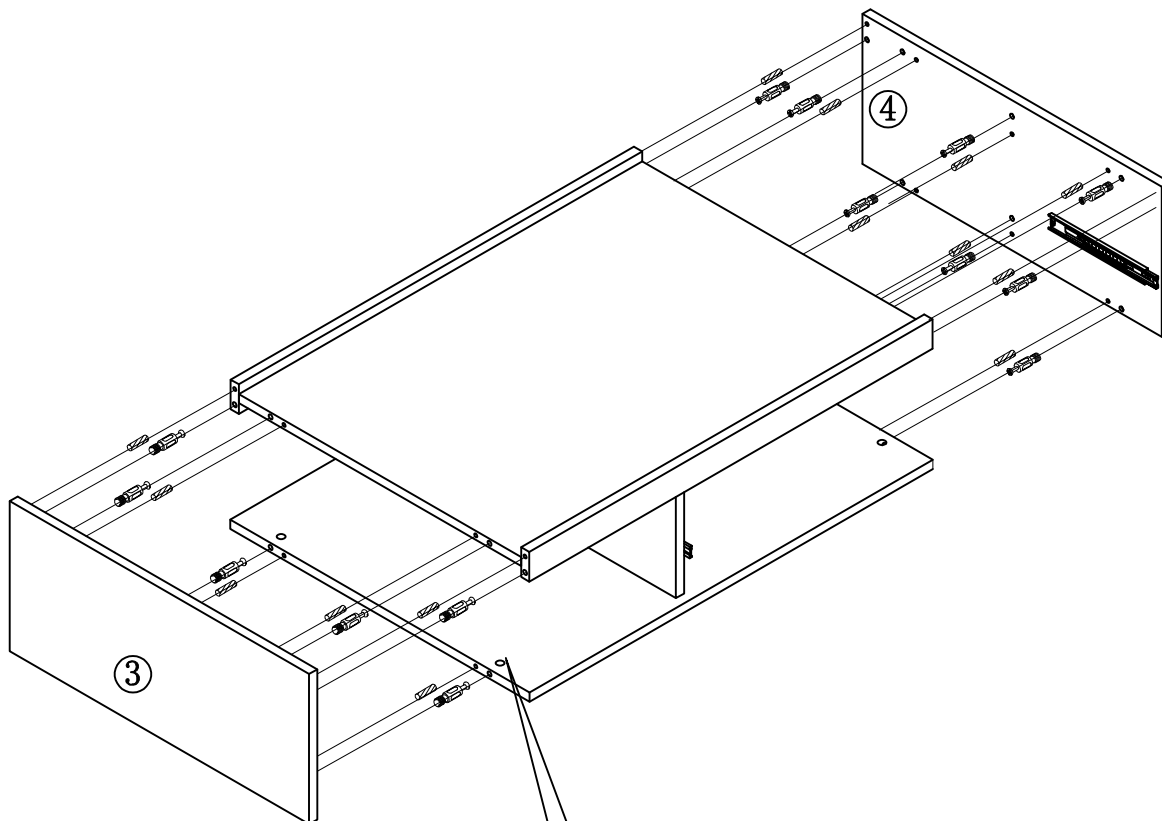

Ⓑ  $\varnothing 15 \times 13.5$ 14pcs

Ⓒ  $\varnothing 8 \times 30$ 14pcs



How to assemble :

STEP 5

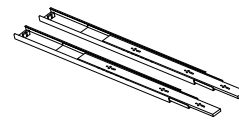
| | | | |
|---|---|-------|------|
| Ⓓ |  | M3*12 | 4pcs |
| Ⓔ |  | M4*30 | 4pcs |
| Ⓕ |  | / | 4set |
| Ⓖ |  | 250mm | 1pa |

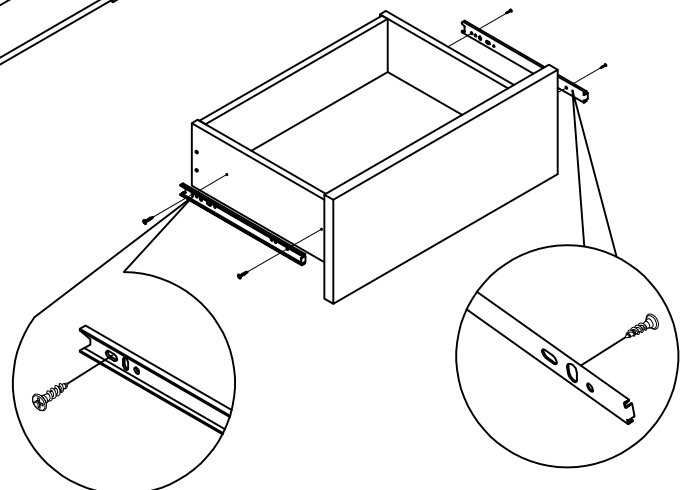
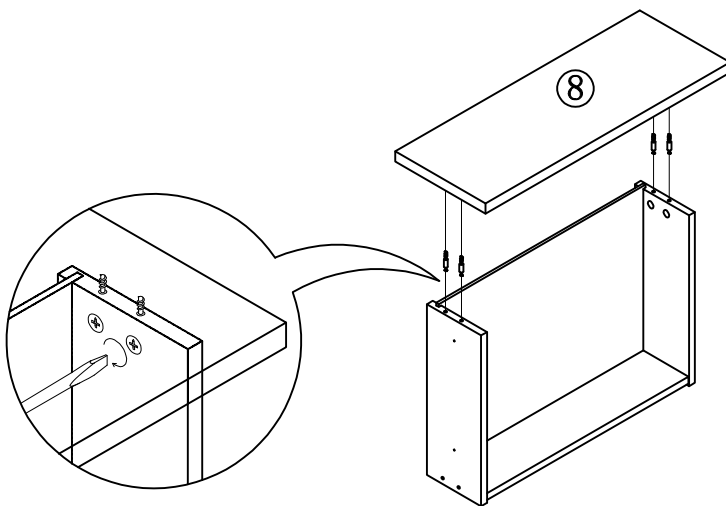
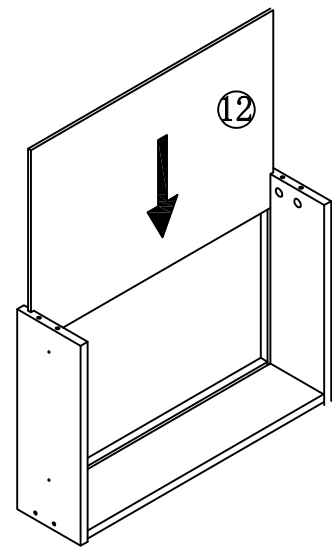
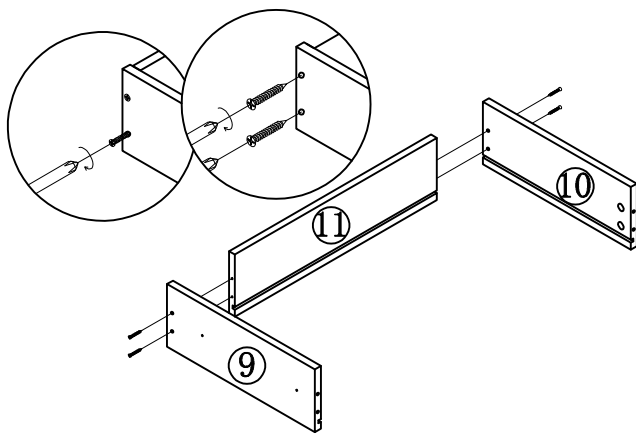

the last hole

the second hole

How to assemble :

STEP 6

Ⓒ



M6H34 ϕ 37

6pcs

Ⓓ



169*23*11.5

1set

