

User Manual

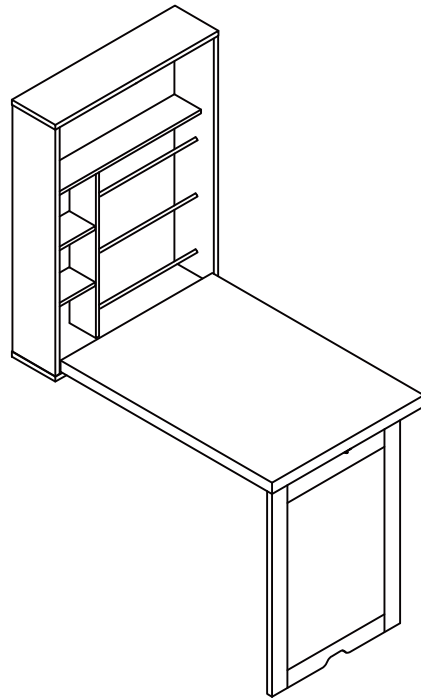

You need

① 2 persons are needed



② Take 45 minutes



Technical Specifications	
Material	PB+PVC
Colour	White
Size	8150X600X160MM

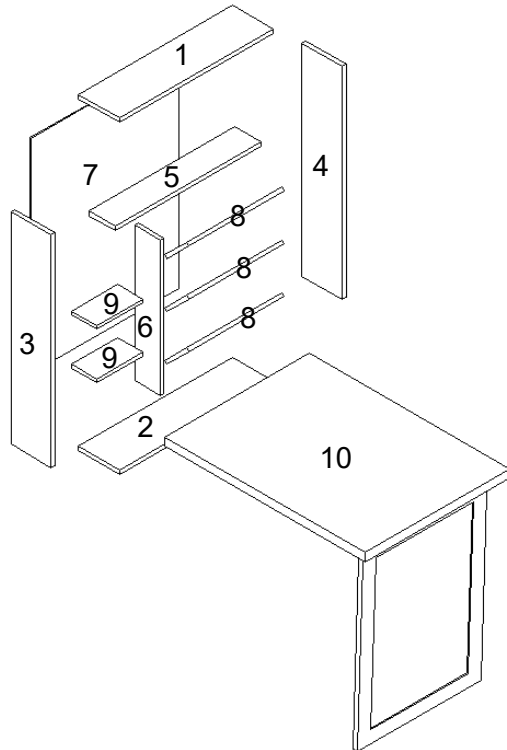





Hardware List

1 1PC	2 1PC	3 1PC	4 1PC
5 1PC	6 1PC	7 1PC	8 3PCS
9 2PCS	10 1PC	A 2PCS Φ12*11	B 28PCS Φ6*30
C 8PCS	D 6PCS Φ3*16	E 1PC	F 1PC
G 1PC	H 6PCS Φ3*20	I 4PCS Φ3.5*12	J 10PCS Φ5*40
K 2PCS	L 6PCS Φ3.5*35	M 6PCS	N 2PCS

PRODUCT ASSEMBLY

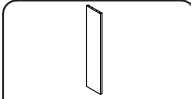
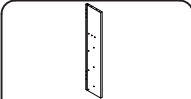
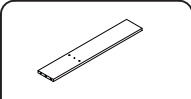
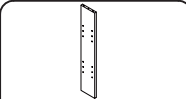
 Check the package contents before getting started!

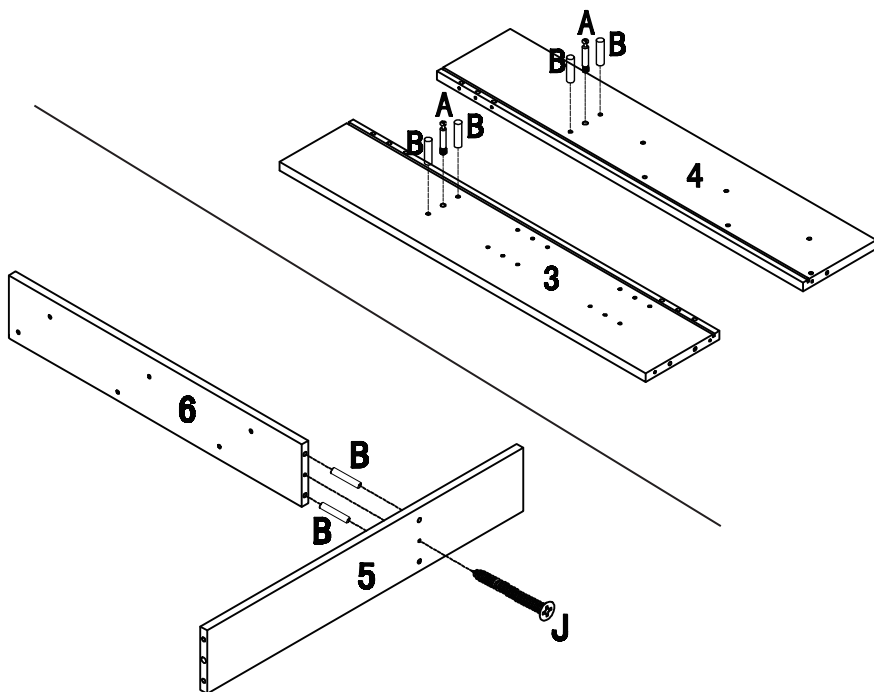

STEP 1

			
3 1PC	4 1PC	5 1PC	6 1PC
			
Φ12*11 A 2PCS	Φ6*30 B 6PCS	Φ5*40 J 1PC	



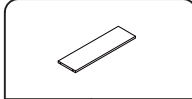
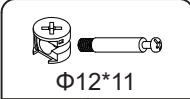

PRODUCT ASSEMBLY

STEP 2

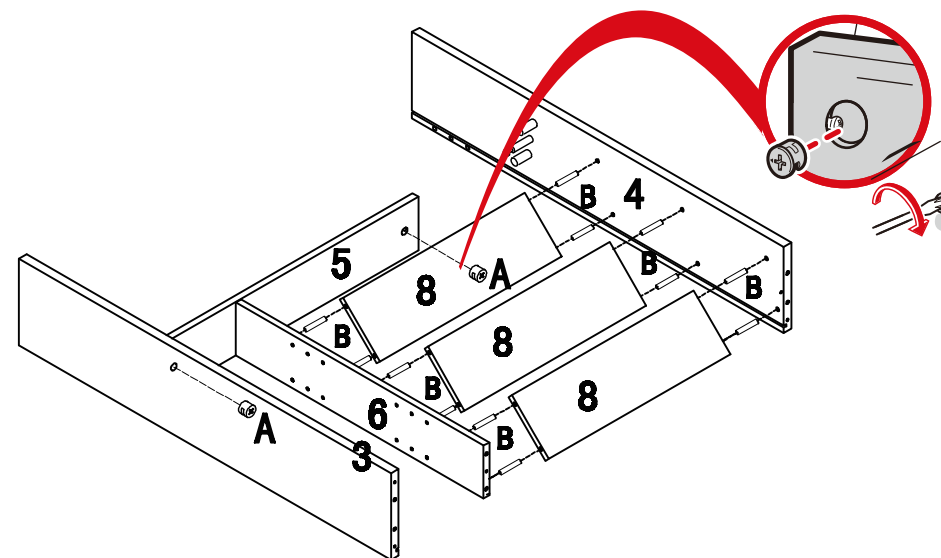
		
8 3PCS	Φ12*11 A 2PCS	Φ6*30 B 12PCS



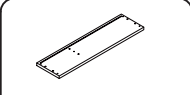
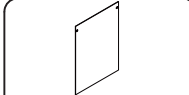

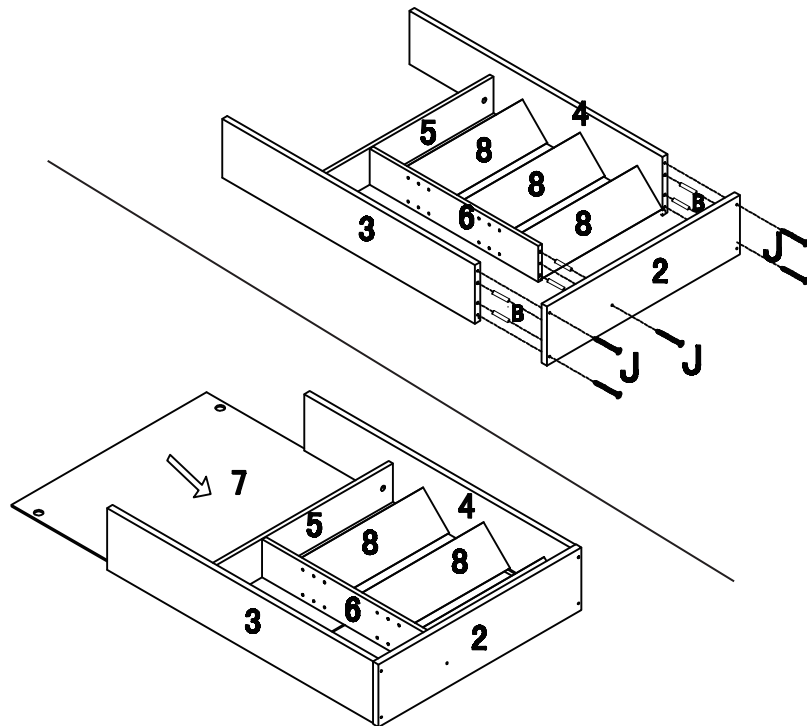

STEP 3

		 Φ6*30	 Φ5*40
2 1PC	7 1PC	B 4PCS	J 5PCS

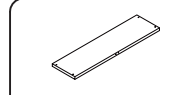

STEP 4

	 Φ6*30		 Φ5*40
1 1PC	B 4PCS	E 1PC	J 4PCS

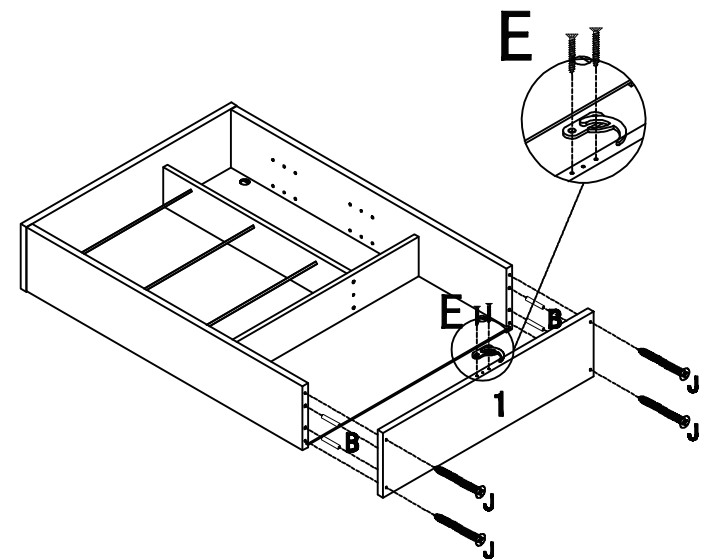

PRODUCT ASSEMBLY

STEP 5

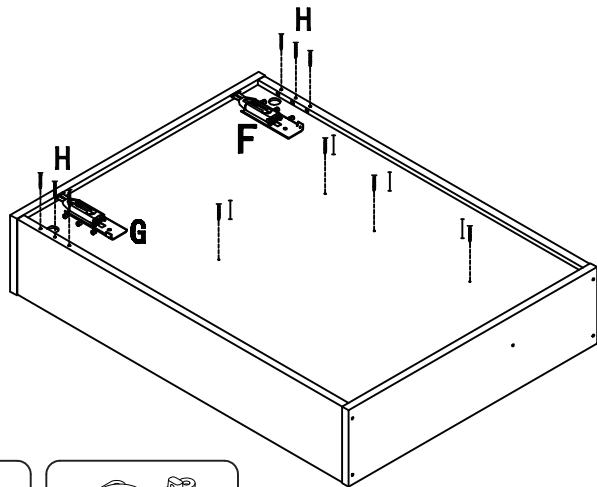
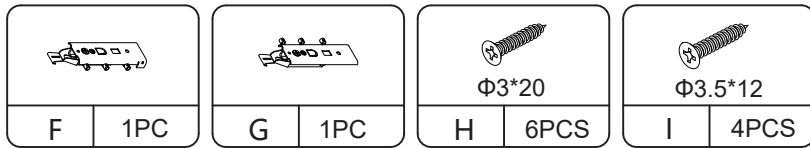

STEP 6

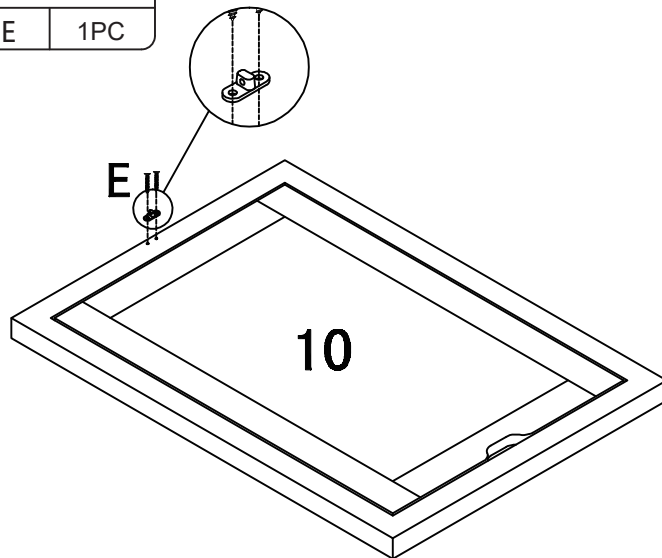
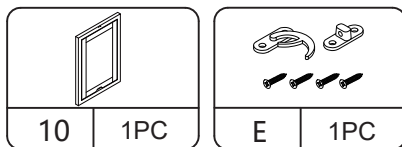

PRODUCT ASSEMBLY

STEP 7

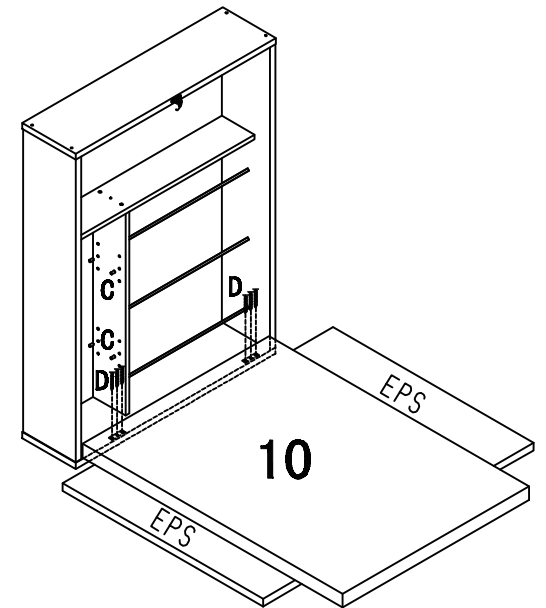

STEP 8

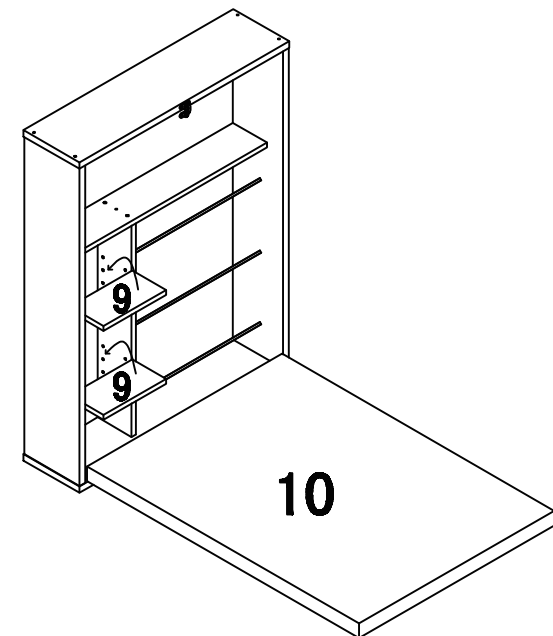
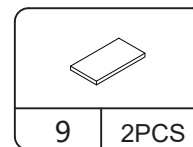

STEP 9

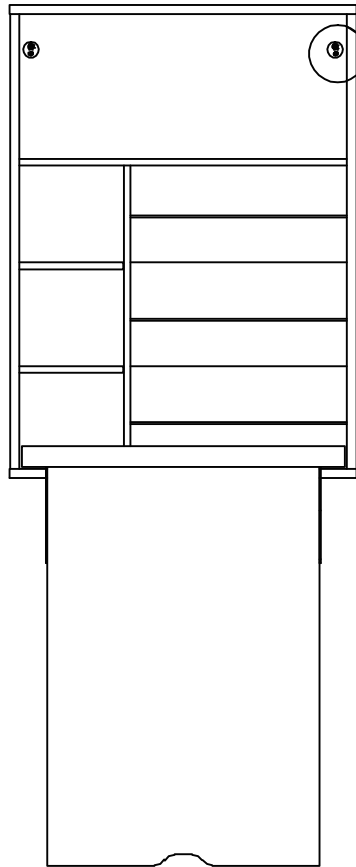
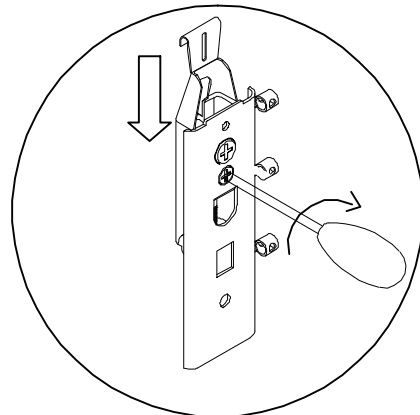
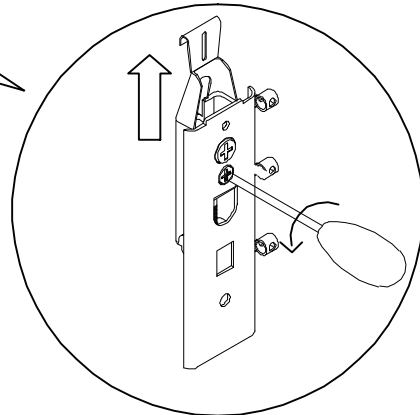
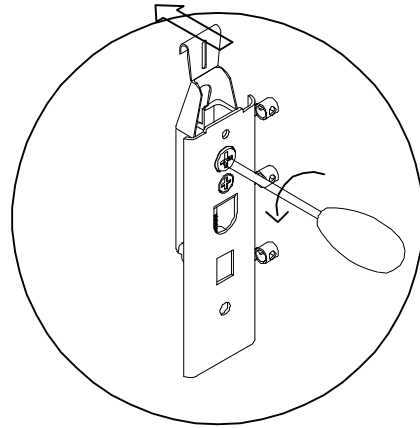

STEP 10

unit:inch

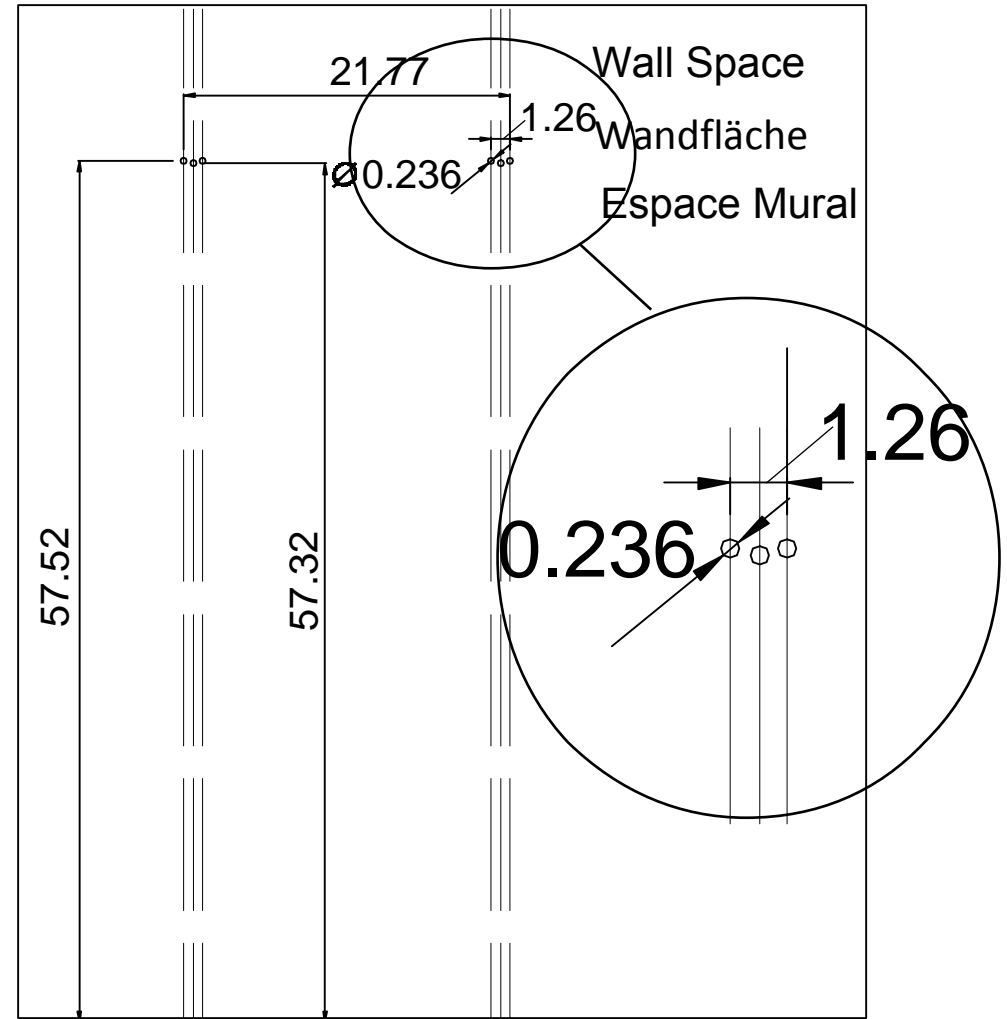

STEP 11

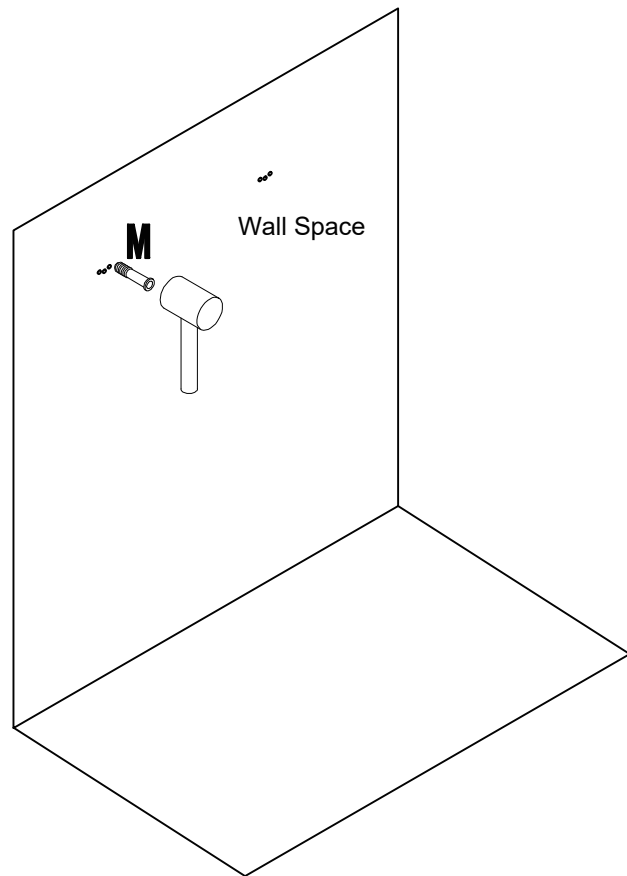
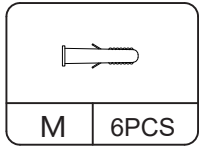

STEP 12

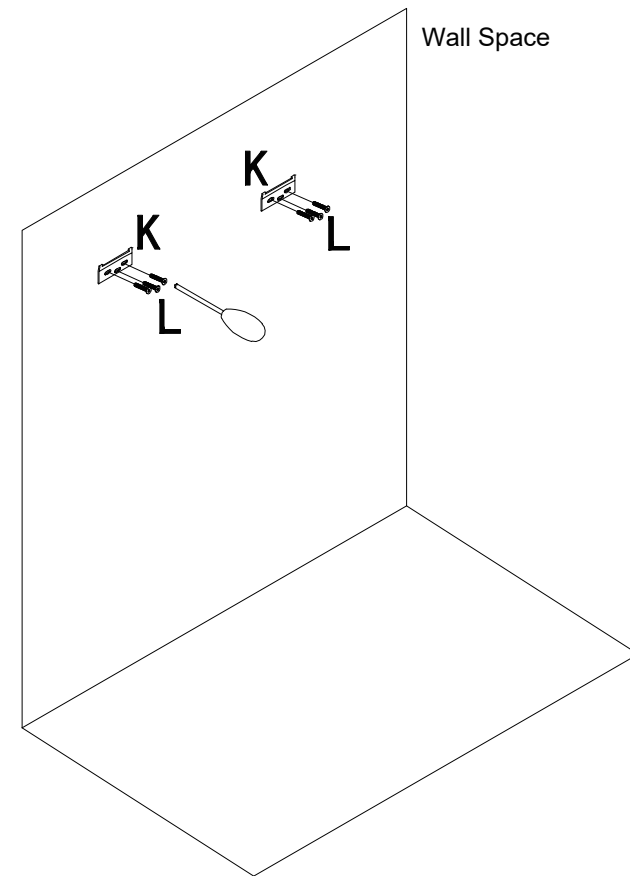
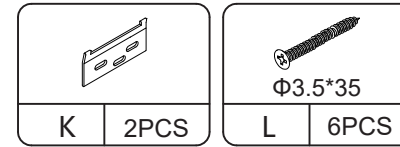

STEP 13

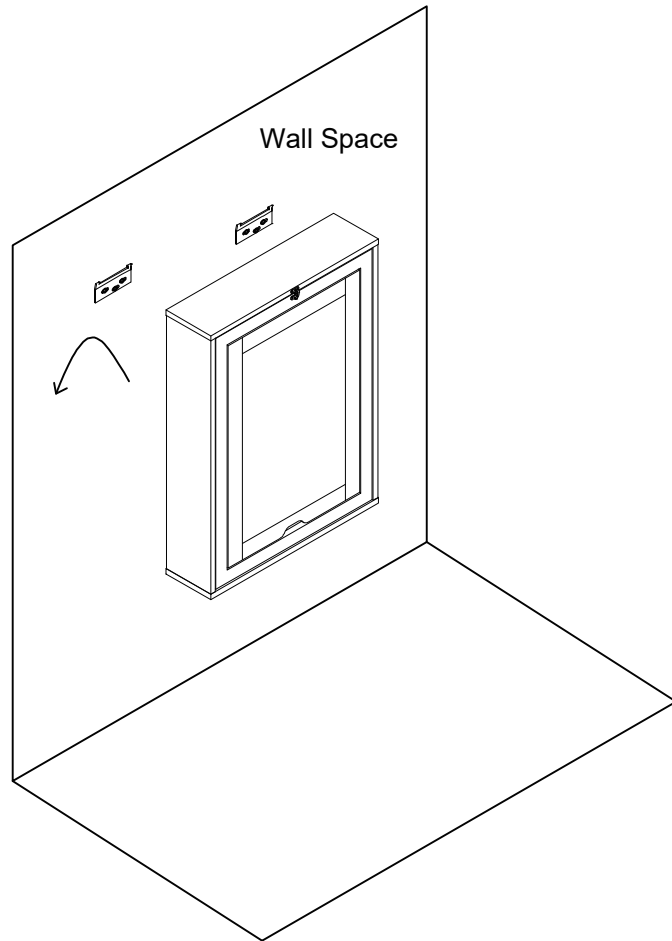

STEP 14

