

# Travel Carrier

## read first REVIEW BEFORE ASSEMBLY

- No tools are required for assembly
- For assistance or replacement parts,  
please contact us.

**1** To assemble the **CAGE BODY**,  
you will need these pieces:

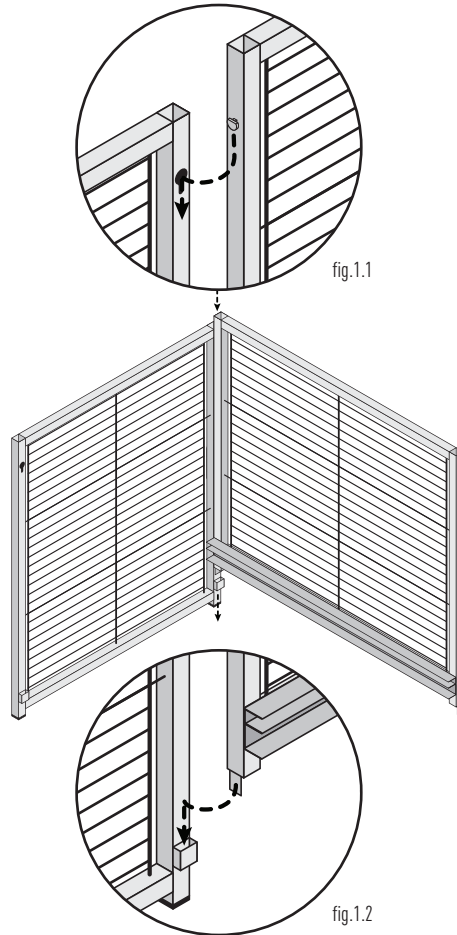
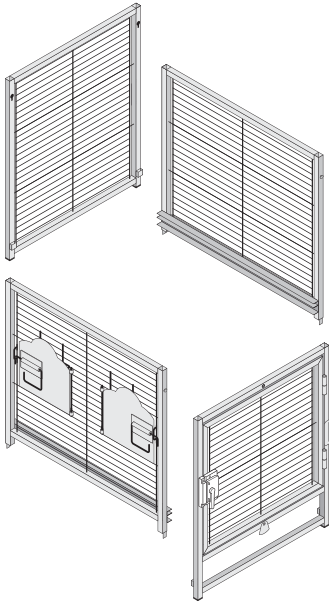

Touch the verticle frame rail surfaces together,  
aligning the knob on the **side panel** with the hole on  
the **back panel** (fig.1.1) and the tab extension on the  
side panel over the sleeve on the back panel (fig.1.2).  
Slide the side panel down. The knob should lock  
into the hole and the tab should slide into the sleeve.  
Add on the **side panel (with cup doors)** and the  
**front panel** following the same procedure.

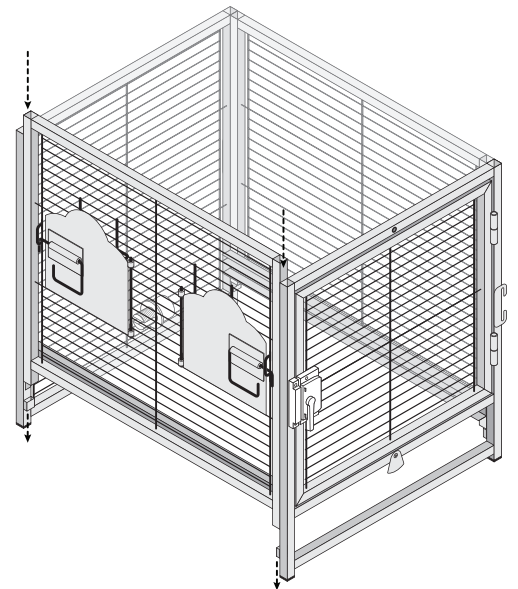

**2** To add the **ROOF** and  
**PERCH / HANDLE**, you  
will need these pieces:

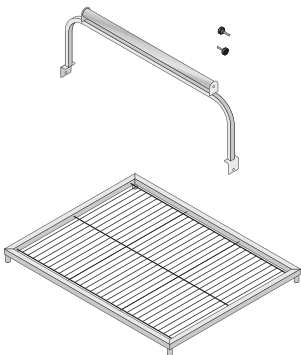

Set the **roof** into place. Posts at the corners of the roof will insert  
into the holes at the top corners of the front and back panels.

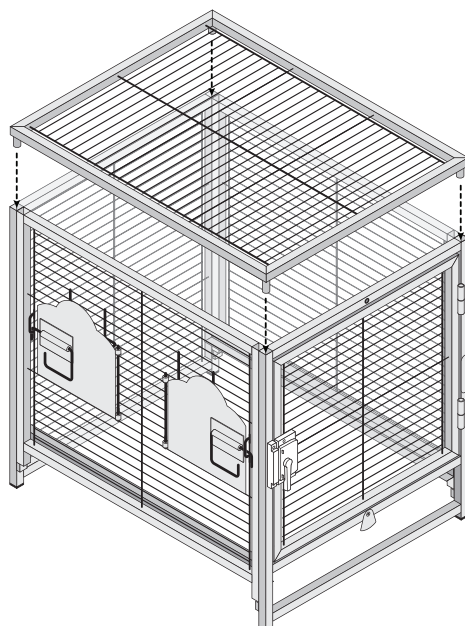

Set the **perch/handle unit** into place, aligning the holes of the  
bottom tabs with the holes on the front and back panels.

Screw the knobs into the aligned holes. This will secure the  
handle to the carrier and lock the roof in place.

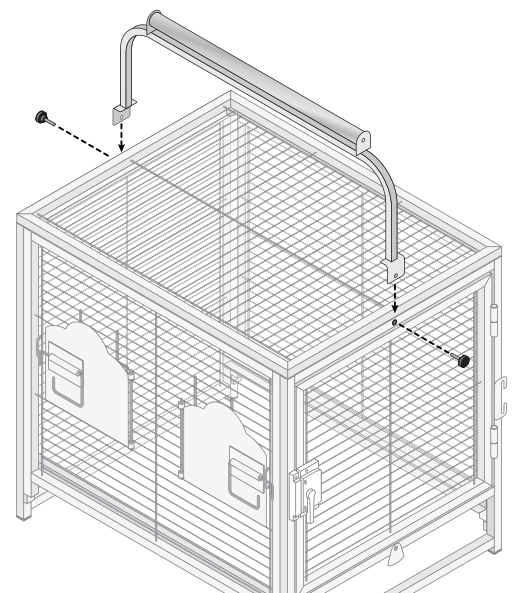

### 3 To add the **COMPONENTS**, you will need these pieces:

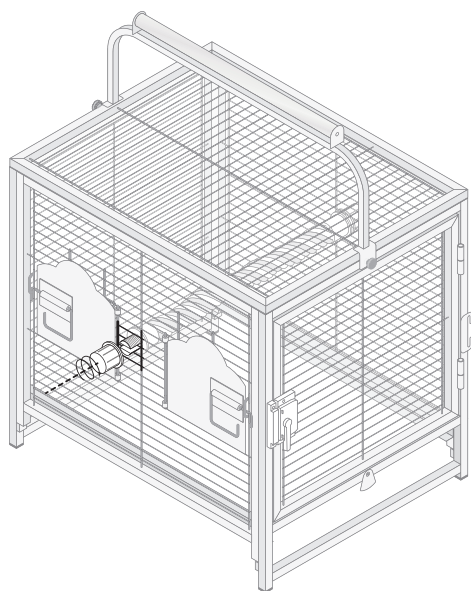
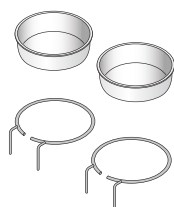
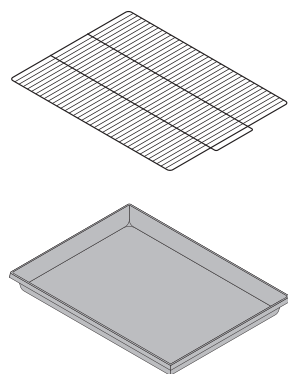
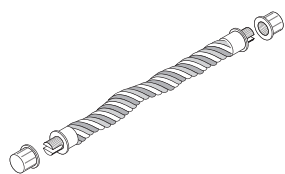

Unscrew the end-caps from the perch ends.  
Place the **perch** inside the carrier and poke the notched screw-post through to the carrier exterior, catching a horizontal wire.

Screw the end-cap onto the screw-post from the exterior (fig.3.1). Tighten to a stable, snug fit.  
Follow the same procedure for the opposite end.

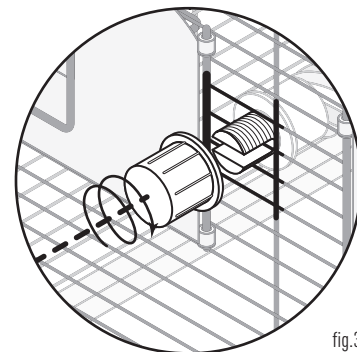
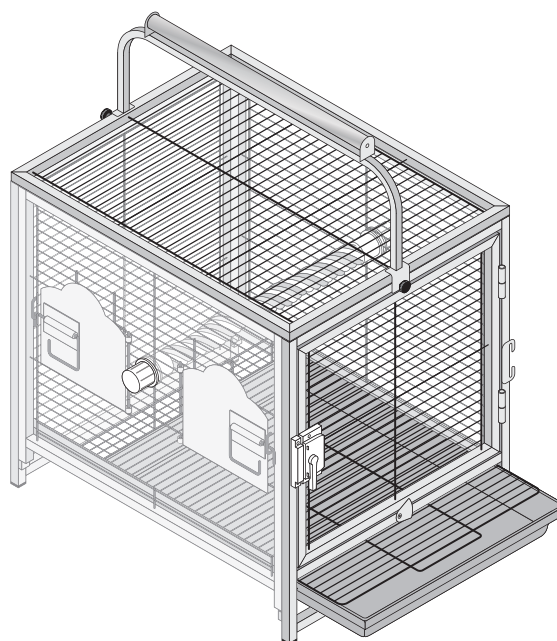
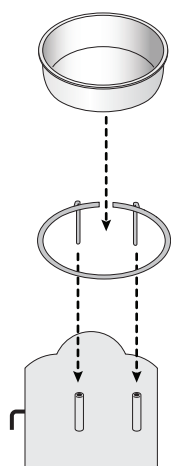

fig.3.1



Rotate the windbell lock out of the way and slide the **grille** into the top track and the **tray** into the bottom track.



Open the cup door, and insert the **cup** into the **cup holder**, and insert the posts of the cup holder into the sleeves on the inside of the door (fig.3.2).

fig.3.2

