

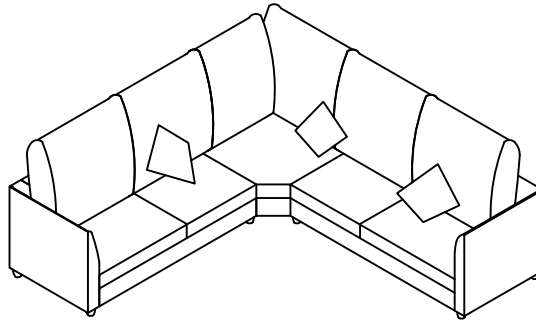















ASSEMBLY INSTRUCTION





WF197841AAE / WF197842AAE / WF197843AAE



Component

| No. | Parts | Description | QTY |
|-----|---|-------------------------------------|-----|
| A |  | Left Seat fram | 1 |
| B |  | Right Seat frame | 1 |
| C |  | Left Arm | 1 |
| D |  | Right Arm | 1 |
| E |  | Soft Back | 2 |
| F |  | Corner Seat | 1 |
| G |  | Long Corner Back | 1 |
| H |  | Short Corner Back | 1 |
| I |  | Leg | 9 |
| J |  | Sofa Seat Cushion | 4 |
| K |  | Corner Seat Cushion | 1 |
| L |  | Pillow for R & L sofa | 4 |
| M |  | Short Pillow for Left corner sofa | 1 |
| Q |  | Length Pillow for Right corner sofa | 1 |
| P |  | Pillow | 3 |

Hardware

| No. | Parts | Description | QTY |
|-----|---|-------------------|-----|
| 1 |  | 5/16" Nut | 10 |
| 2 |  | 5/16" Flat washer | 10 |
| 3 |  | 5/16" Lock washer | 10 |
| 4 |  | Wrench | 1 |
| 5 |  | Hang Bolt | 10 |

WF197841AAE

A C E*2 J*1 L*4

WF197842AAE

B D G H M J*2 Q P*3 I*9 Hardware bag

WF197843AAE

F K J*1

STEP 1:

1. Screw the Hang Bolts (5) into bottom of Sofa Back (E). Make sure there is enough length of the Hang Bolt (5) for next step as show in Figure 1.
2. Attach Sofa Back (E) to Sofa Seat (A) using Flat Wahsher (2), Lock Washer (3) and Nut (1). tighten with Wrench(4) as show in Figure 2.

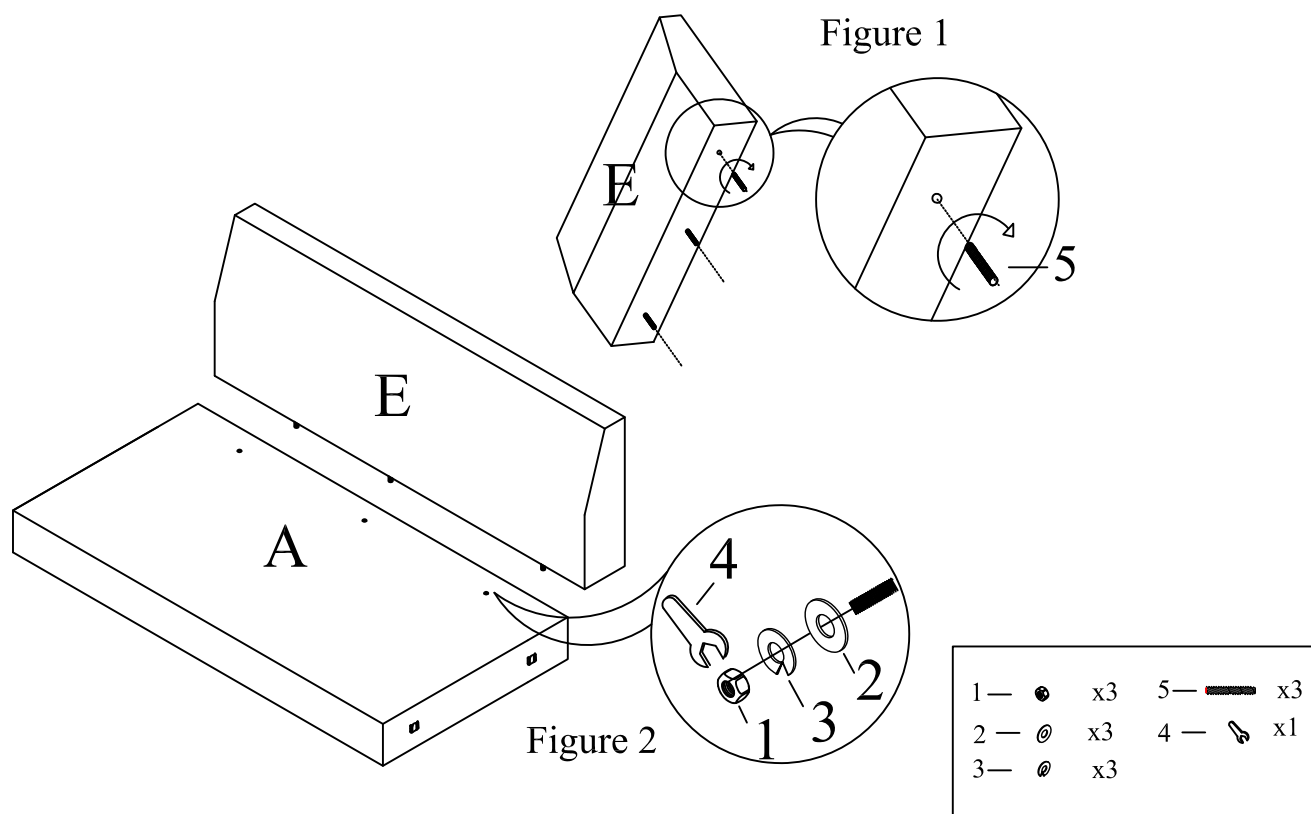

STEP 2: Insert 2 pieces of Legs (I) into the bottom of Left Arm Seat (A) by turning as shown.

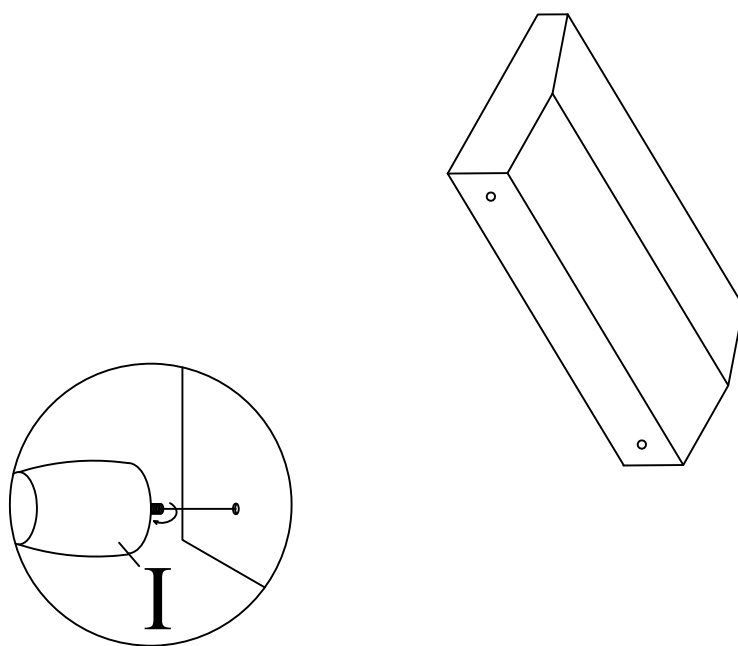

STEP 3: Attach Left Seat frame (A) and Sofa Back (E) to Left Armrest (C) by Hook as shown.

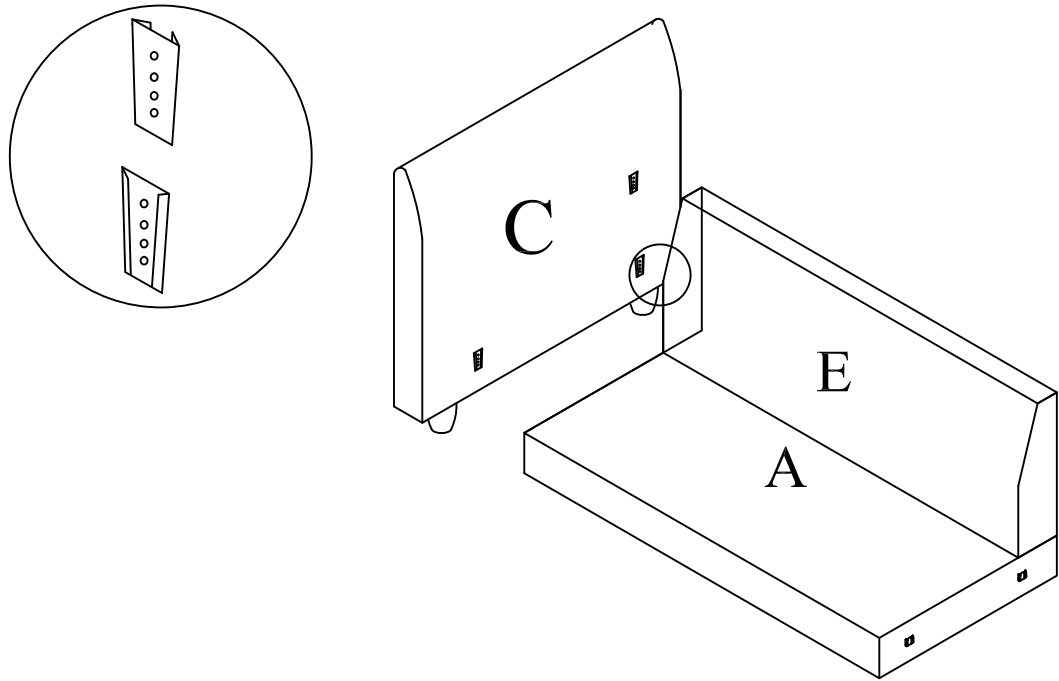

STEP 4:

Repeat the same steps 1,2,3 for Right Arm Sofa.

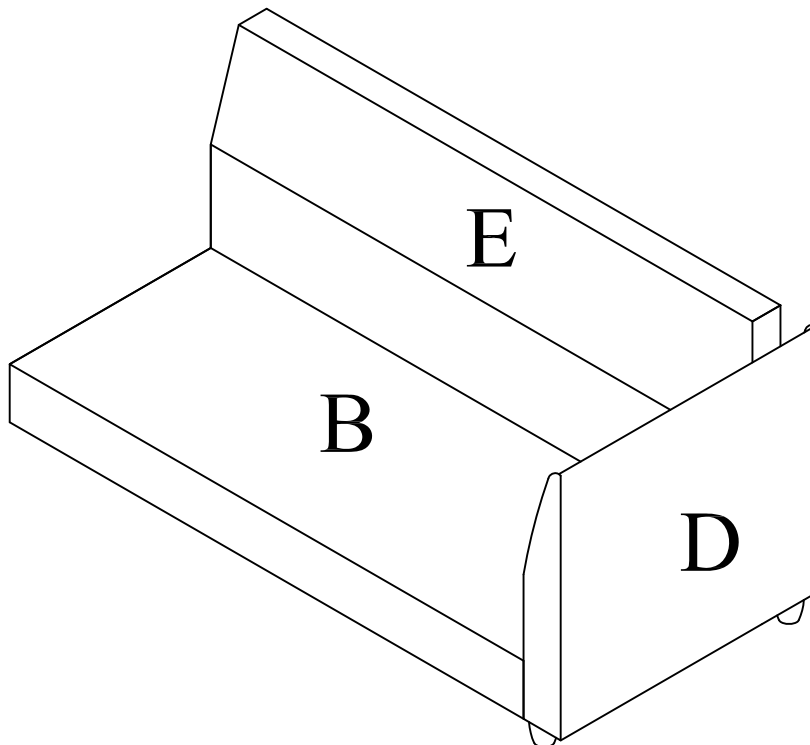

| | | | |
|-------|----|-------|----|
| 1 — ● | x3 | 5 — █ | x3 |
| 2 — @ | x3 | 4 — ⚙ | x1 |
| 3 — @ | x3 | | |

STEP 5:

1. Attach Long Corner Back (G) to Short Corner Back (H) by Hook as shown in Figure 1.
2. Screw the Hang Bolts (5) into bottom of Long Corner Back (G) and Short Corner Back (H). Make sure there is enough length of the Hang Bolt (5) for next step as shown in Figure 2.
3. Attach Long Corner Back (G) and Short Corner Back (H) to Corner Seat (F) using Flat Washer (2), Lock Washer (3) and Nut (1). tighten with Wrench(4) as shown in Figure 3.

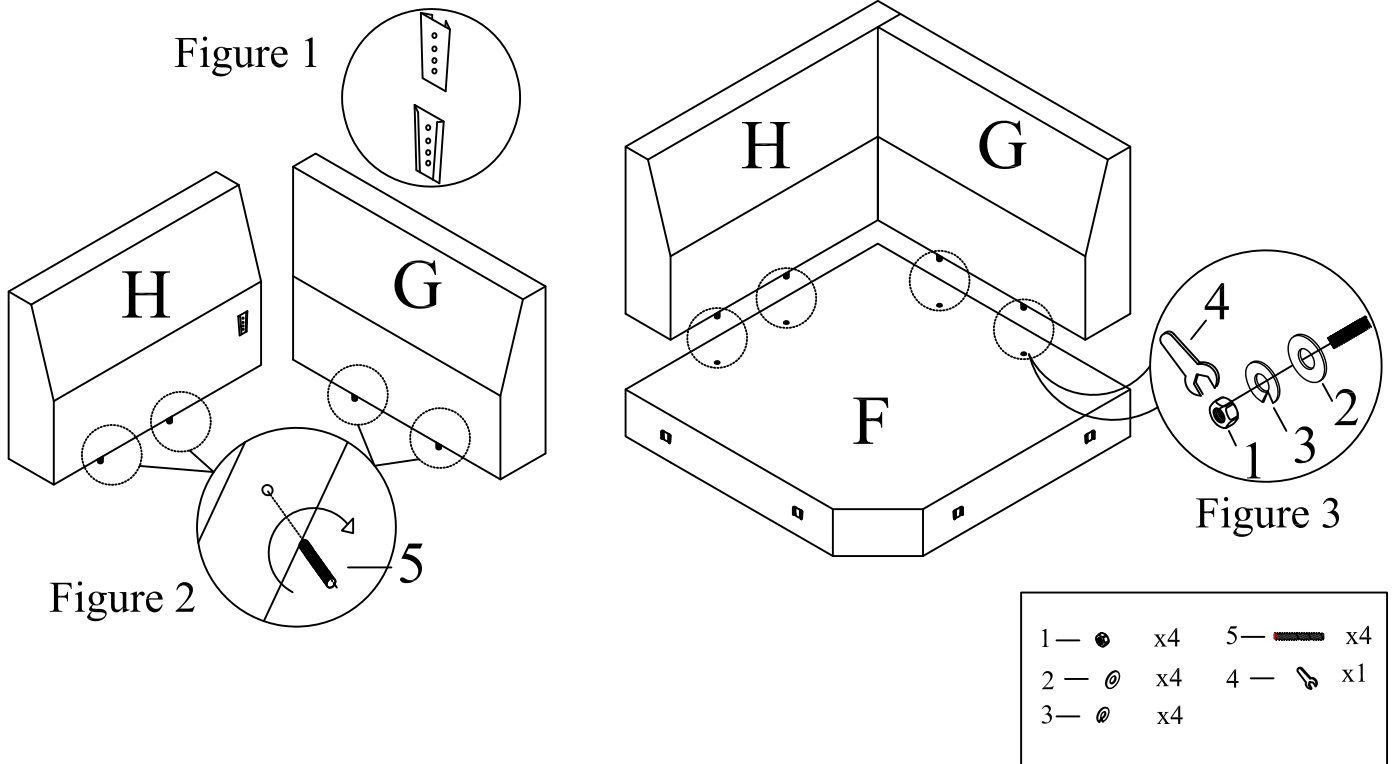

STEP 6:

Insert 5 piece of Legs (I) into the bottom of Corner Seat (F) by turning as shown.
Your Corner assemble complete.

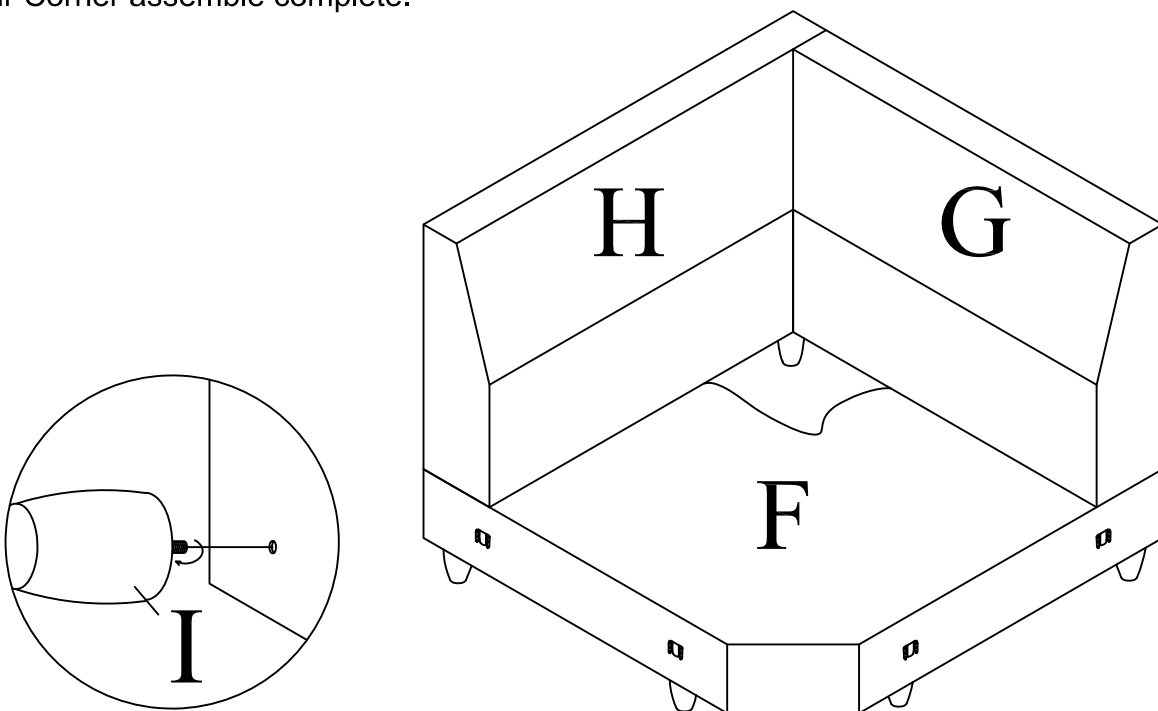

STEP 7:

Put Left Sofa, Right Sofa and Corner together by Connecting Connector Brackets as shown.

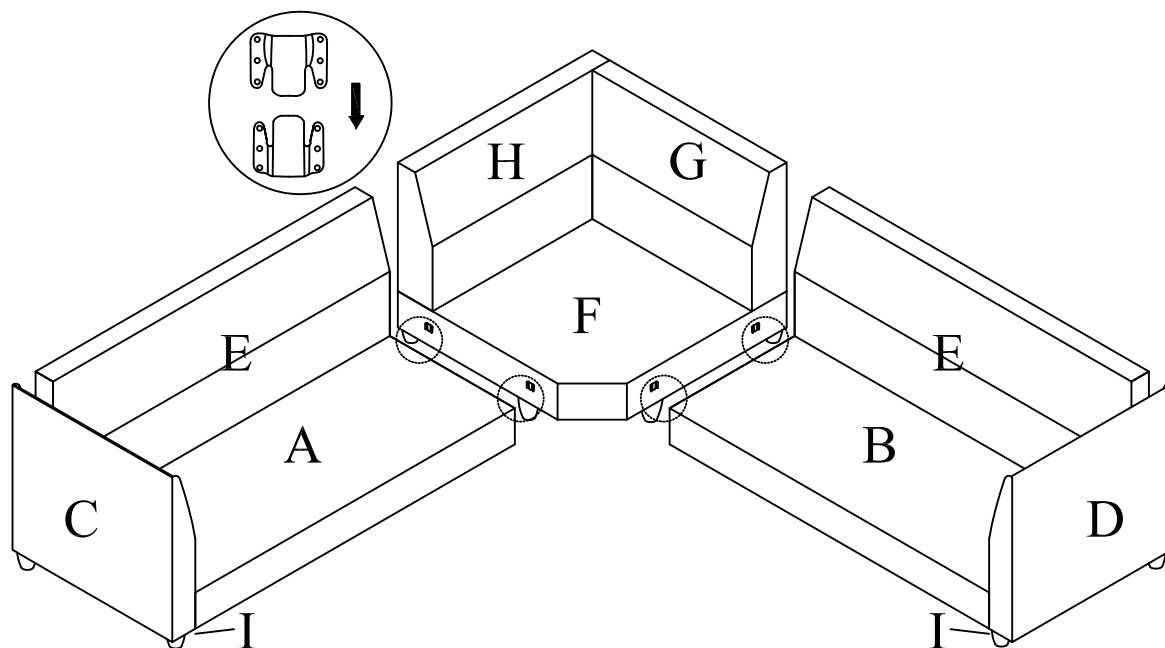

STEP 8:

Put the Pillows and the Cushions on the Sofa Collection.

