

ASSEMBLY INSTRUCTIONS

DINING TABLE

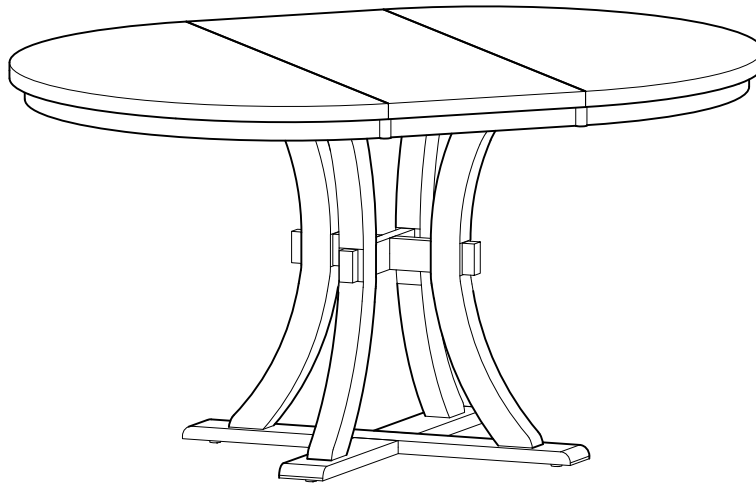

WF317557

IMPORTANT NOTE:

- PLACE ALL PARTS ON A CLEAN AND SMOOTH SURFACE SUCH AS A RUG OR CARPET TO AVOID THE PARTS FROM BEING SCRATCHED.
- BEFORE YOU BEGIN, KINDLY FOLLOW THE ASSEMBLY INSTRUCTIONS STEP BY STEP.
- DO NOT TIGHTEN ALL SCREWS AND BOLTS UNTIL THE TABLE IS FULLY SET-UP.

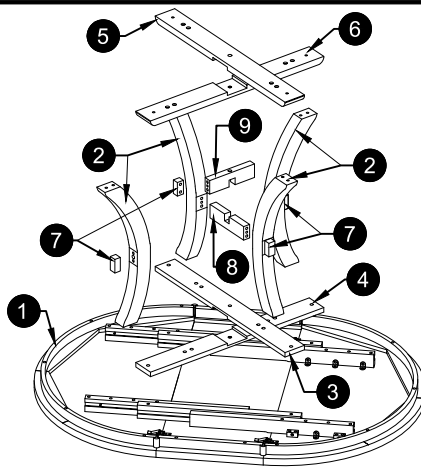

CARTON CONTENT:

WF317557 :



1 x 1



2 x 4

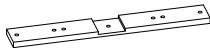

3 x 1

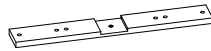

4 x 1

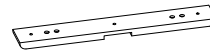

5 x 1

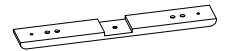

6 x 1



7 x 4

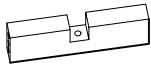

8 x 1

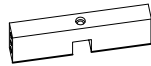

9 x 1

TABLE PART LISTS

NO.	DESCRIPTION	SKETCH	QTY
1	TABLE TOP		1 PC
2	TABLE LEG		4 PCS
3	LEG SUPPORT (L)		1 PC
4	LEG SUPPORT (R)		1 PC
5	BOTTOM LEG (L)		1 PC
6	BOTTOM LEG (R)		1 PC
7	MIDDLE SUPPORT CAP		4 PCS
8	MIDDLE SUPPORT (R)		1 PC
9	MIDDLE SUPPORT (L)		1 PC

TABLE HARDWARE LISTS

NO.	DESCRIPTION	SKETCH	QTY
A	JCBC BOLT M6 x 70mm		4 PCS
B	JCBC BOLT M6 x 40mm		21 PCS
C	JCBC BOLT M6 x 20mm		2 PCS
D	SPRING WASHER 1/4"		27 PCS
E	FLAT WASHER 1/4"		14 PCS
F	WOOD DOWEL M10 x 30mm		16 PCS
G	ALLEN KEY M4		1 PC
H	ADJUSTER M6 x 23mm		4 PCS

NOT INCLUDED

STEP 1

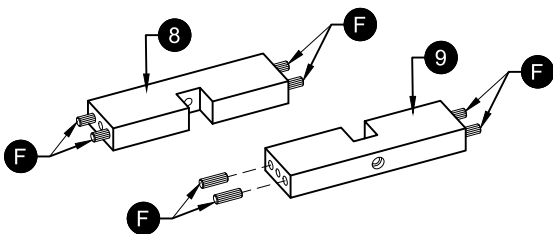

STEP 2

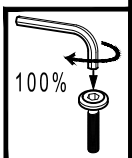
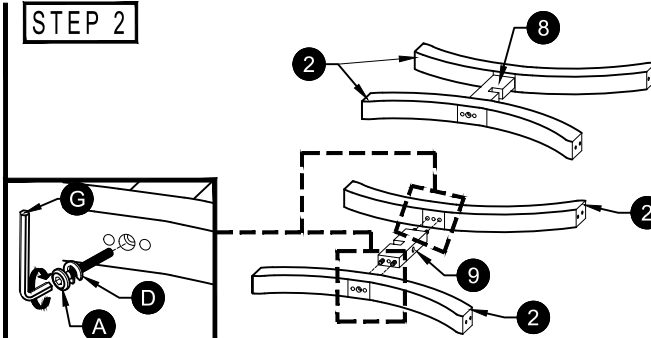

STEP 3

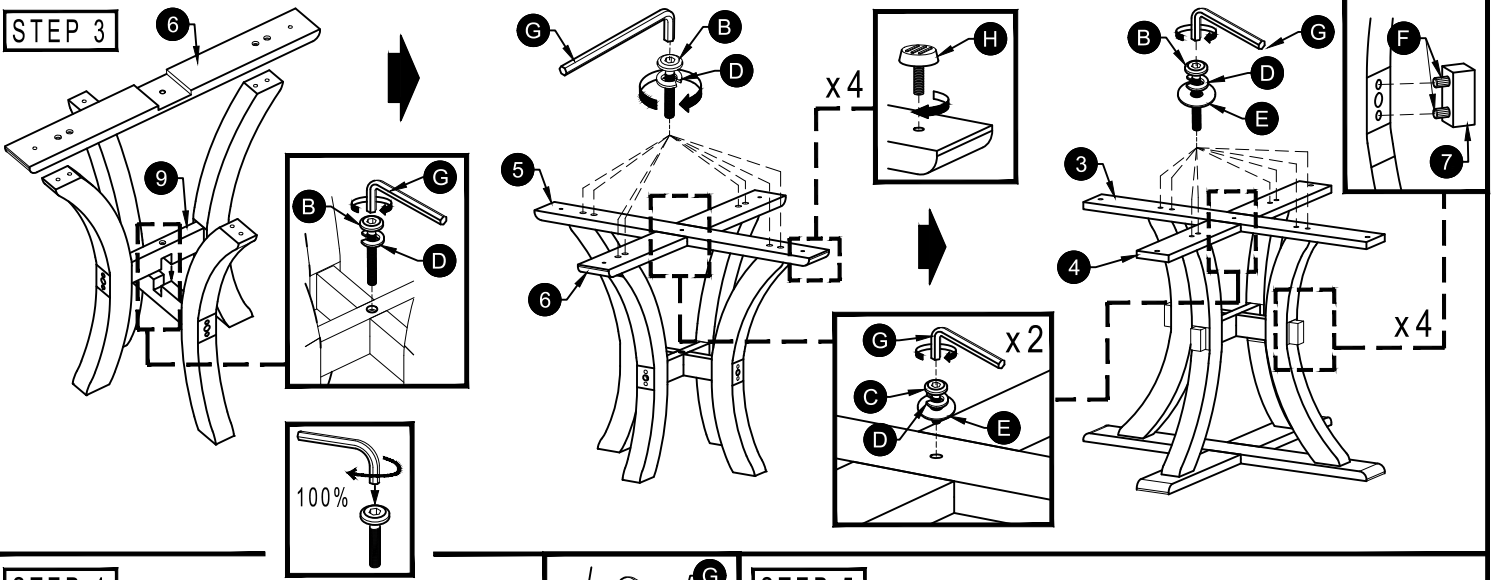

STEP 4

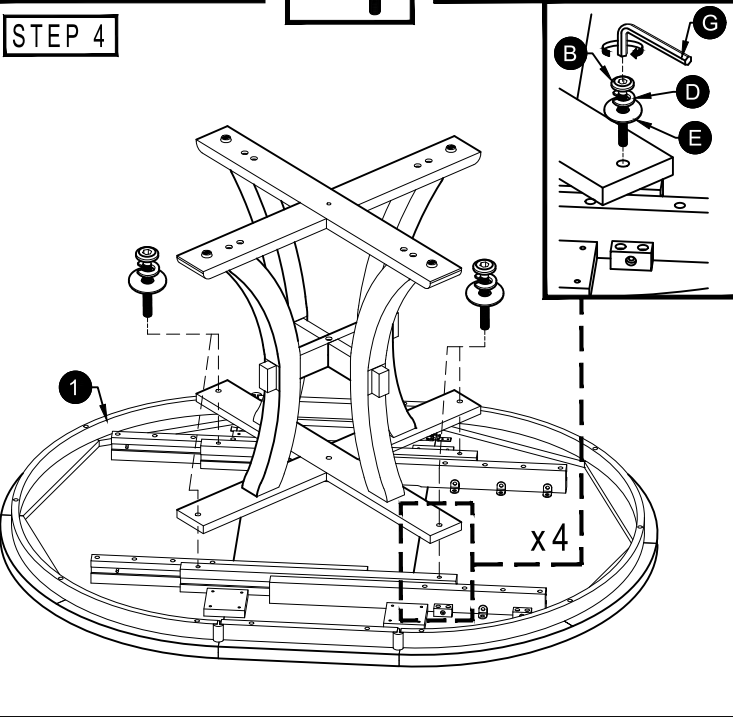

STEP 5

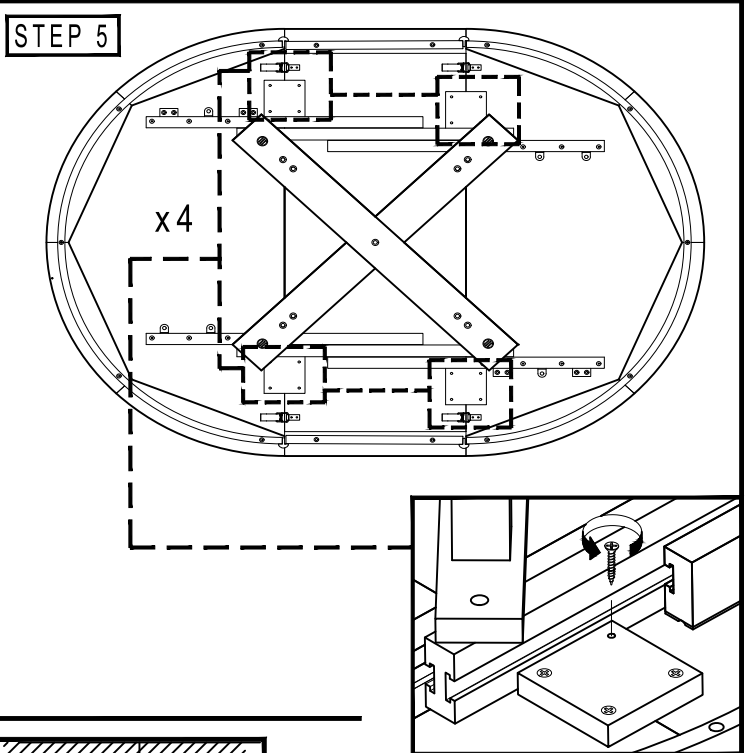

STEP 6

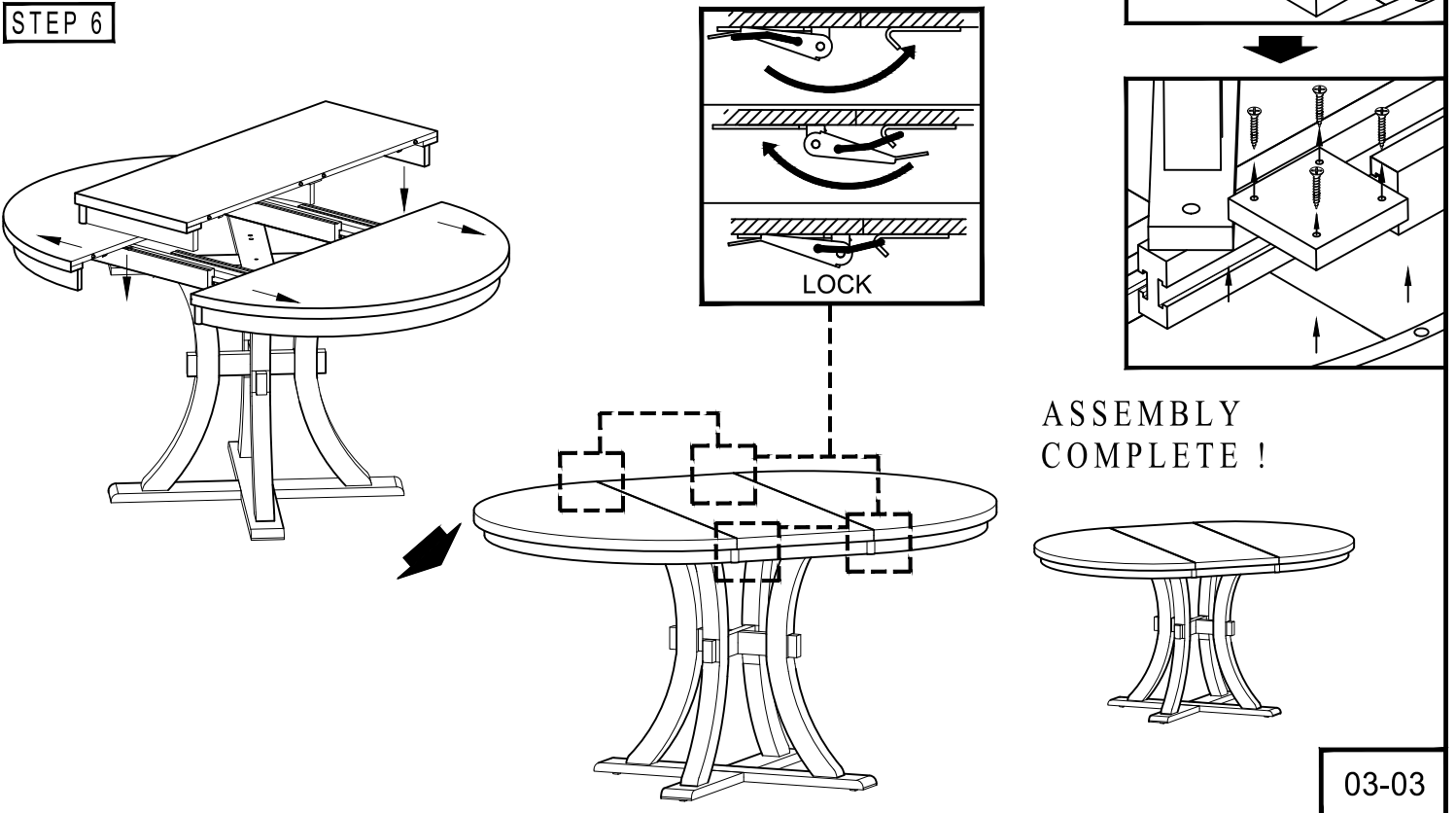

ASSEMBLY COMPLETE !

ASSEMBLY INSTRUCTIONS

DINING CHAIR

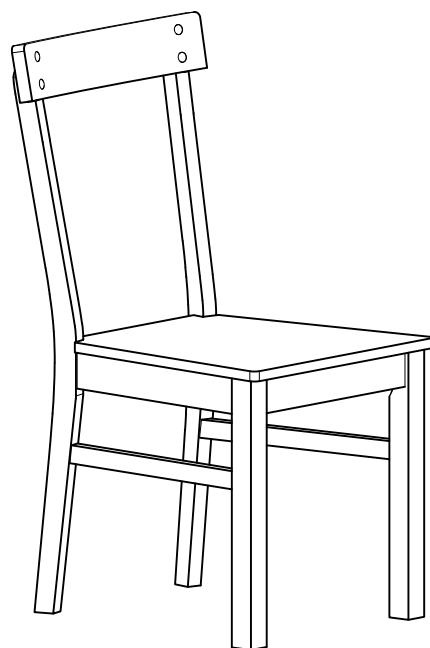

WF317558

IMPORTANT NOTE:

- PLACE ALL PARTS ON A CLEAN AND SMOOTH SURFACE SUCH AS A RUG OR CARPET TO AVOID THE PARTS FROM BEING SCRATCHED.
- BEFORE YOU BEGIN, KINDLY FOLLOW THE ASSEMBLY INSTRUCTIONS STEP BY STEP.
- DO NOT TIGHTEN ALL SCREWS AND BOLTS UNTIL THE CHAIR IS FULLY SET-UP.

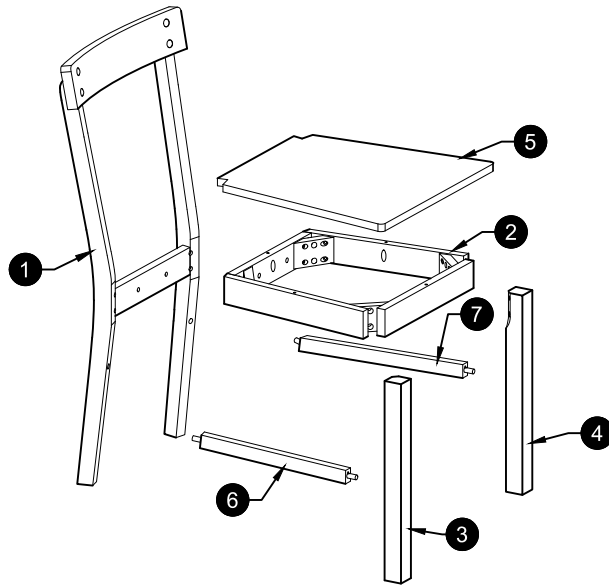

CARTON CONTENT:

WF317558 :

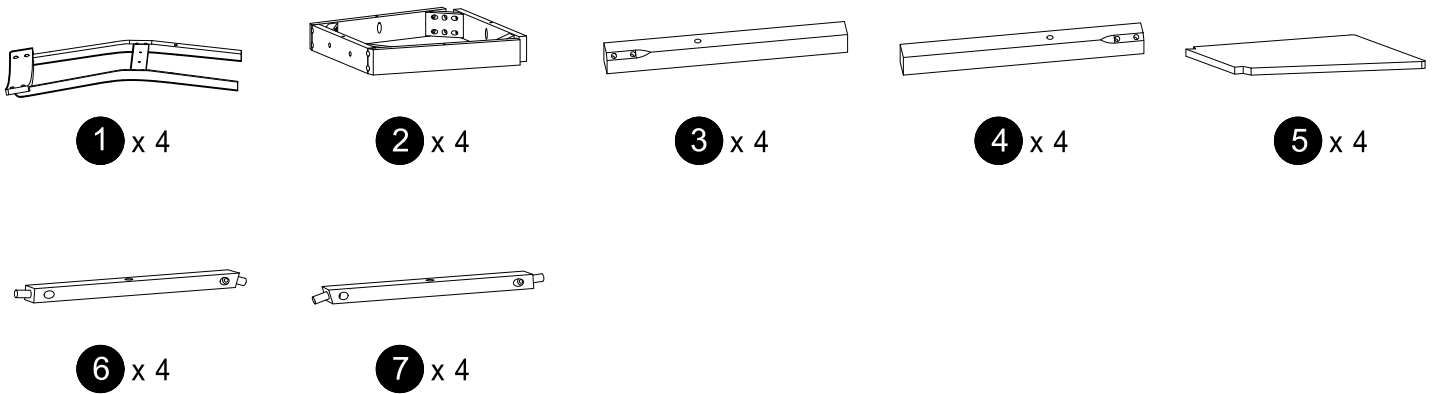

CHAIR PART LISTS

NO.	DESCRIPTION	SKETCH	QTY
1	BACK LEG		4 PCS
2	BOX SEAT		4 PCS
3	FRONT LEG (L)		4 PCS
4	FRONT LEG (R)		4 PCS
5	SEAT		4 PCS
6	STRETCHER (L)		4 PCS
7	STRETCHER (R)		4 PCS

CHAIR HARDWARE LISTS

NO.	DESCRIPTION	SKETCH	QTY
A	JCBC BOLT M6 x 35mm		8 PCS
B	JCBC BOLT M6 x 60mm		16 PCS
C	JCBC BOLT M6 x 80mm		16 PCS
D	SPRING WASHER 1/4"		40 PCS
E	FLAT WASHER 1/4"		40 PCS
F	ALLEN KEY M4		1 PC
G	C/B SCREW M4 x 30mm		16 PCS
H	C/B SCREW M4 x 45mm		16 PCS

NOT INCLUDED

