

# INSTRUCTION

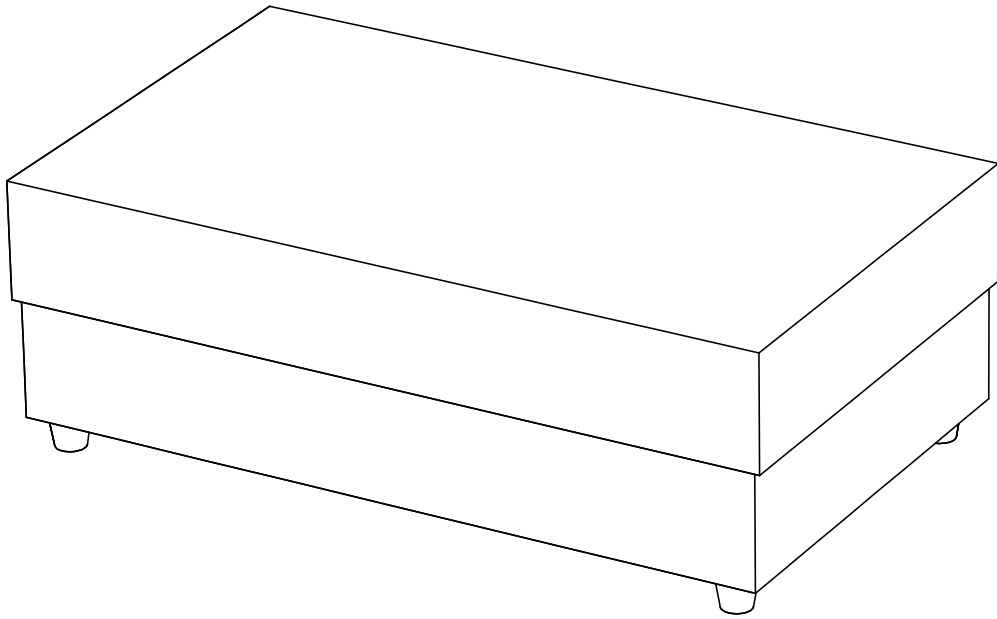

**Notice:** As the cushions are vacuum-compressed, allow up to 72 hours for them to return to their original shape. To expedite this process, you may knead the cushions gently, similar to a massage, to facilitate air circulation through the foam. This will enhance the cushions' rebound and help them become fluffy. If there are any wrinkles, use an iron to gently smooth them out.



Ottoman

# PARTS LIST

**A** x1

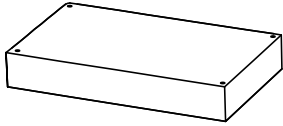

Ottoman Frame

**B** x1

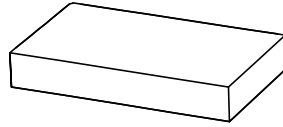

Ottoman Seat Cushion

**C** x4



Leg

## Step1

Ship by 1 box

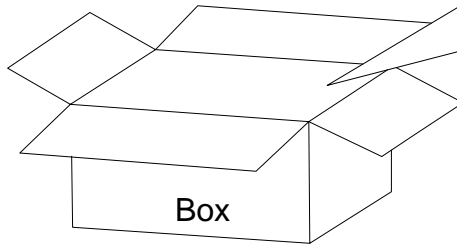

**A** x1

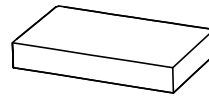

**B** x1



**C** x4

## Step2

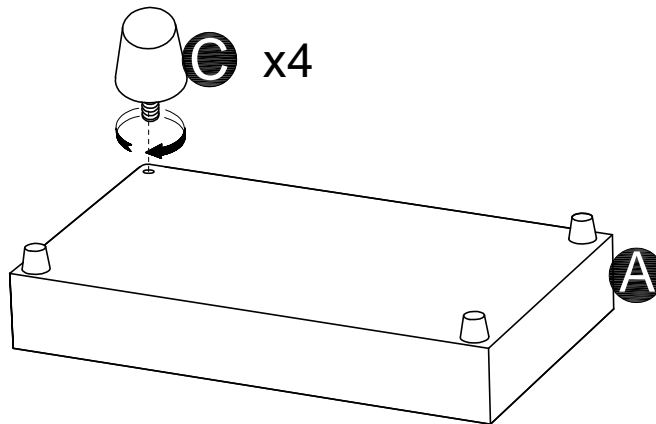

## Step3

