

Assembly Instructions

Model No. YDS-Y0039

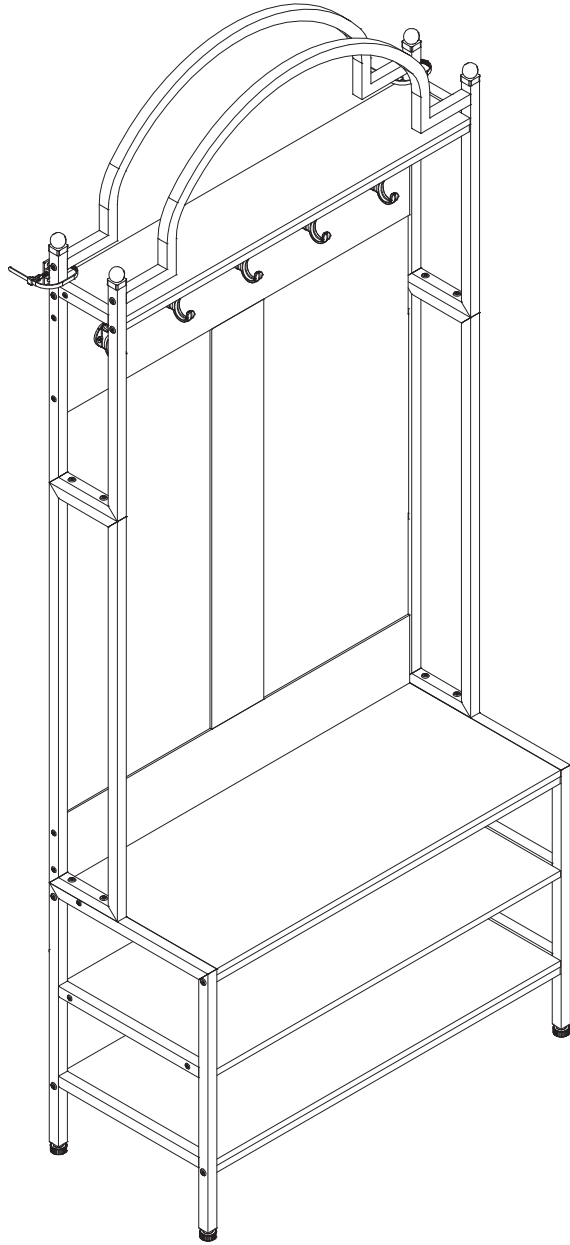

Notes: Don't tighten screws completely at first, just in case parts were assembled wrong and need be disassembled. Tighten screws at last when all parts are put together.

Contact us!

We're here to help!

If you have any issues with this product, please contact our customer service team **before returning** it.



We want you to be completely satisfied with your purchase! If anything is missing, damaged, incorrect, or not what you expected, don't worry. Please keep the outer packaging and take photos of both the packaging and products, and then reach out to us at **YDS13538281408@163.com** We'll take care of everything and send you a free replacement, so you can enjoy your purchase as soon as possible without any hassle.

Assembly Instructions:

1. Carefully read these instructions and keep them for future reference.
2. Refer to the parts list for guidance and ensure that you have all the pieces before starting the assembly process, if anything is missing, damaged, incorrect, contact us **FIRSTLY BEFORE** assembling.
3. When assembling, place all parts on a soft, clean, and flat surface, such as a carpet, to prevent any scratches.
4. To avoid misalignment of the holes, Please don't full tighten the screws until you ensure all parts in place.

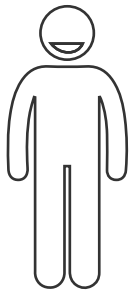

X2

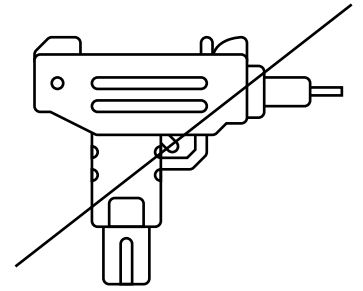
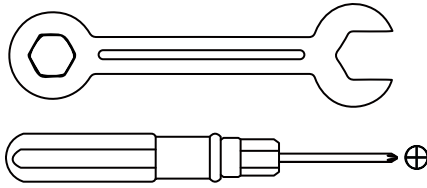

When using the electric screwdriver ,
Reduce the power and torque to avoid damaging the furniture

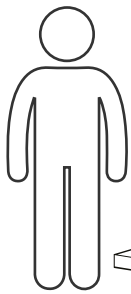

?

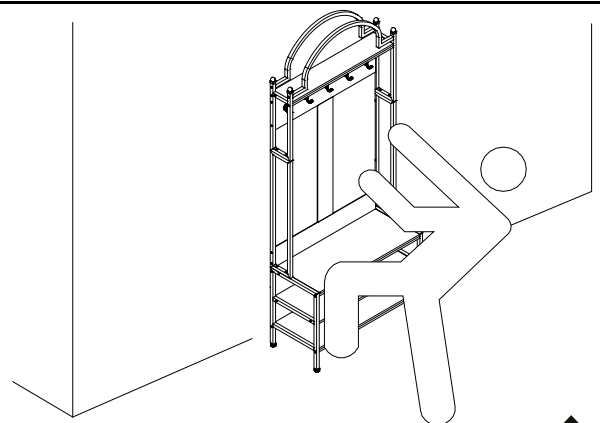
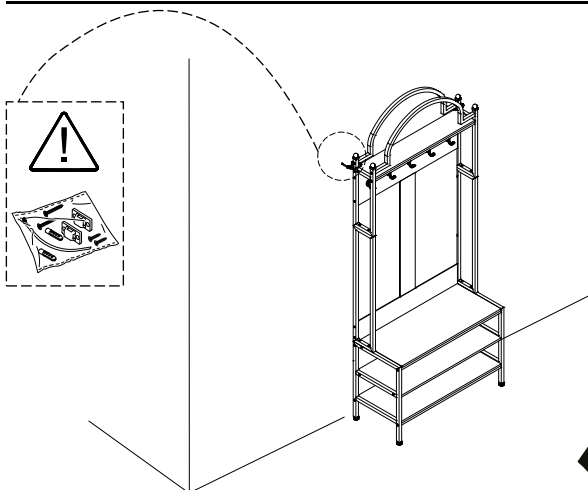
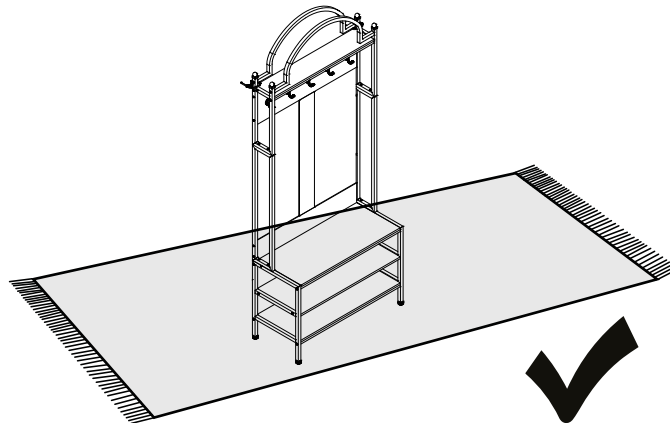
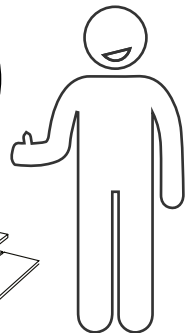
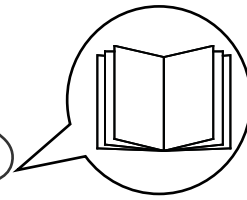
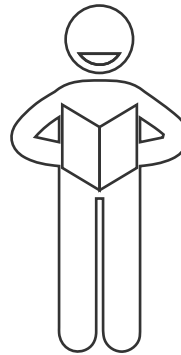
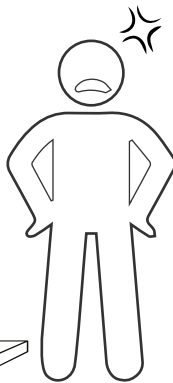

(Install tip-over restraint provided)

Use of tip-over restraints may only reduce but not eliminate
the risk of tip-over.

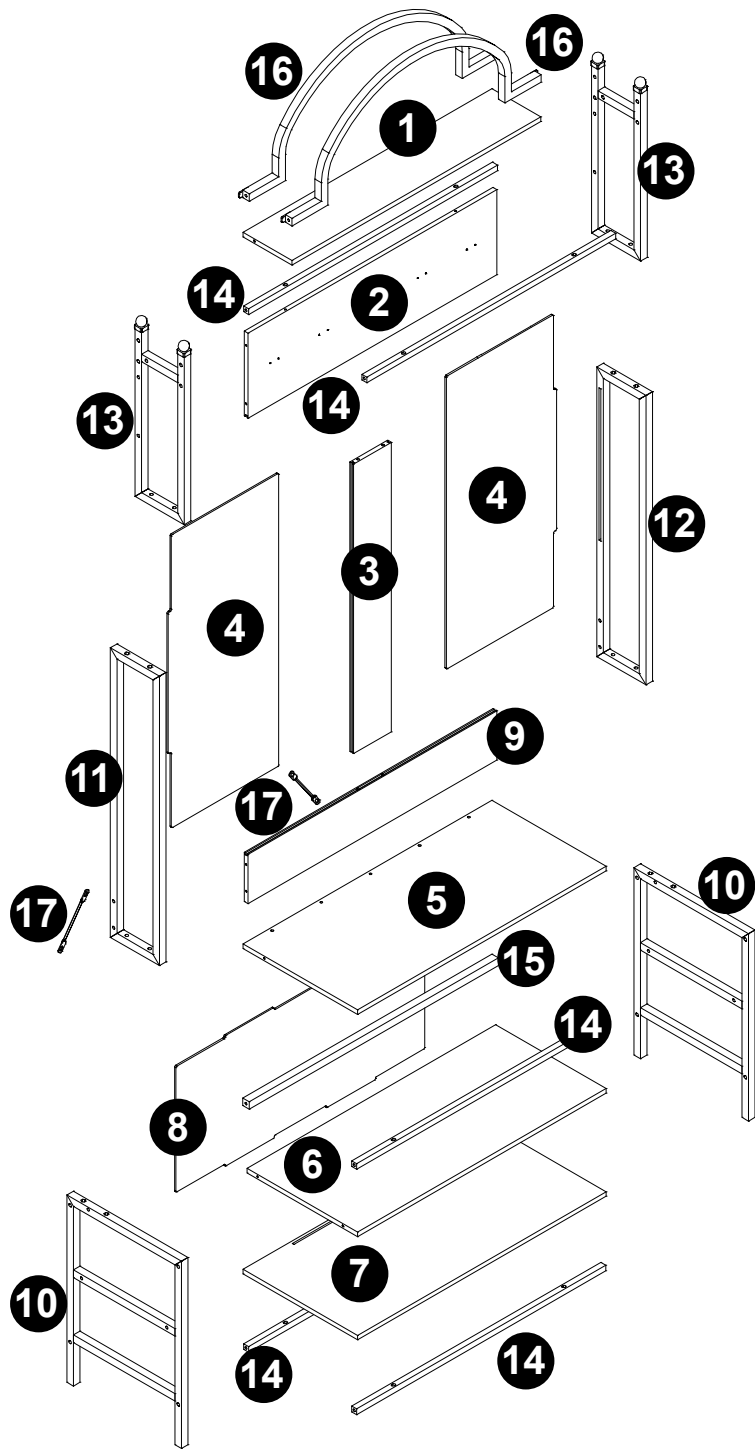

⚠ Caution

Make sure all parts are included. Most board parts are labeled or stamped on the raw edge. Contact us for free replacement if having damaged or missing parts

Parts & Hardware List

759X149X12

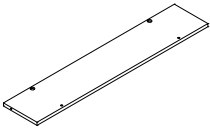

1 1pc

759X224.5X12

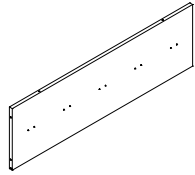

2 1pc

765X115X12

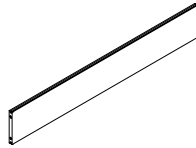

3 1pc

774X337X4

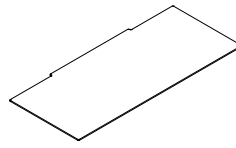

4 2pc

759X349X12

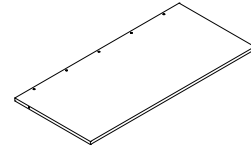

5 1pc

759X337X12

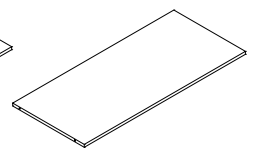

6 1pc

759X349X12

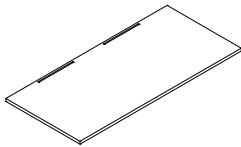

7 1pc

759X345X4

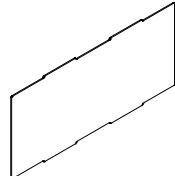

8 1pc

759X130X12

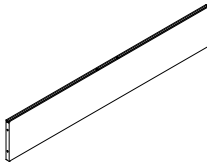

9 1pc

495X350

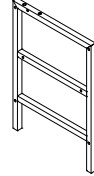

10 2pc

765X150

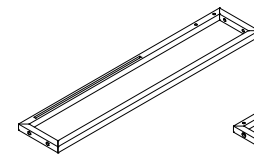

11 1pc

765X150

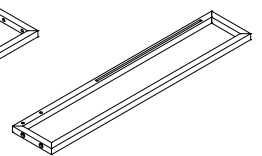

12 1pc

452X150

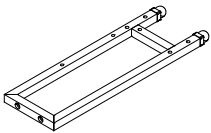

13 2pc

15X15X760

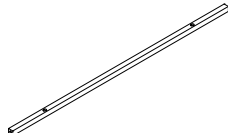

14 5pc

20X20X760

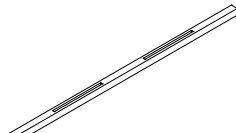

15 1pc

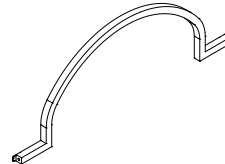

16 2pc

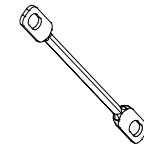

17 2pc

50X50X1.5

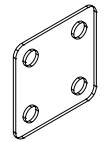

18 2pc

M8

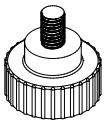

19 4pc



20 5pc

Hardware List



M5X40MM

A

18pcs



M6X40MM

B

16pcs



M6X30MM

C

8pcs



M6X23MM

D

8pcs



M6X10MM

E

12pcs



M4X14MM

F

10pcs



M6X40MM

G

6pcs



M15X9

H

3pcs



I

3pcs



M3X16MM

J

8pcs



K

8pcs



L

4pcs

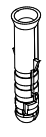

M

4pc

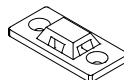

N

2pcs



O

2pcs

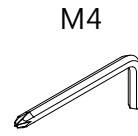

M4

P

1pcs

Installation of Cams and Pins

Screw the pin into the hole. To set the cams correctly, ensure that the arrow on the cam is opening to the hole of the pin it is locking. Lock the cam by turning the cam head with a screwdriver until it is tightened. Please do not use an electric screwdriver to assemble the unit.

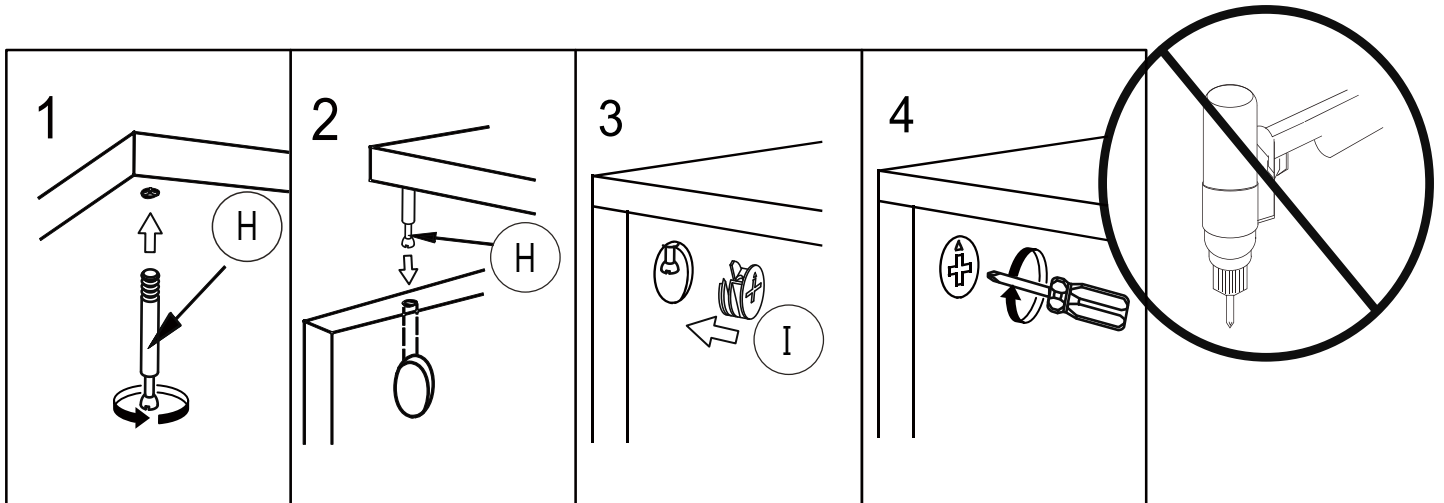

Read each step carefully before starting. It is very important that each step of instruction is performed in the correct order. If these steps are not followed in sequence, assembly difficulties will occur.

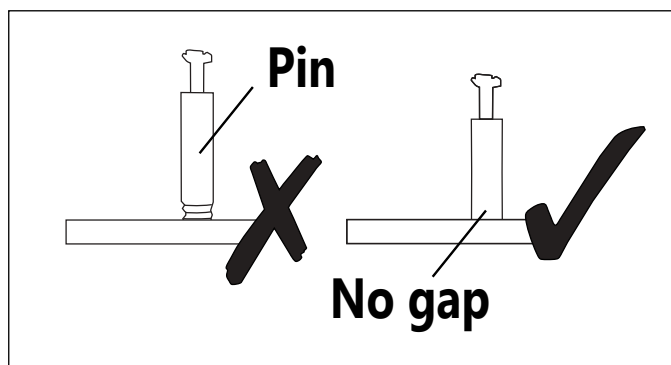

1

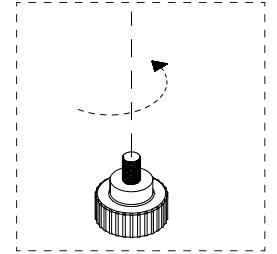
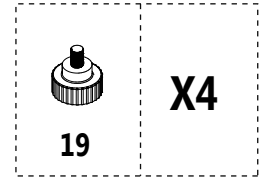
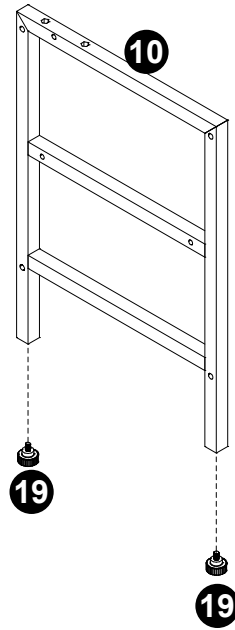
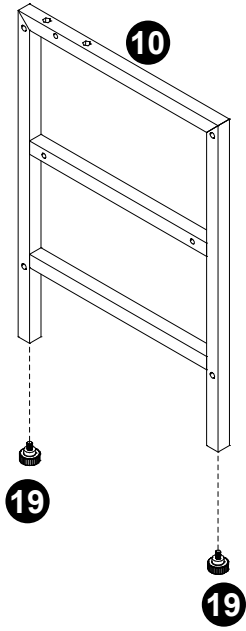
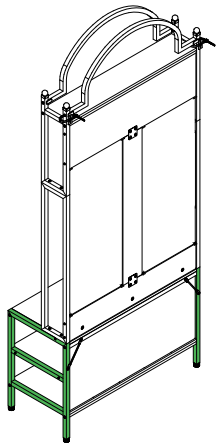
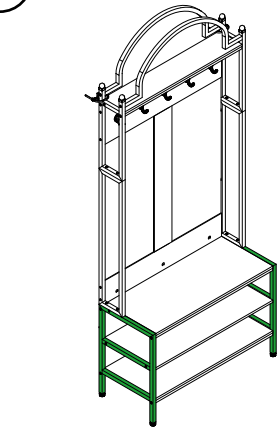

2

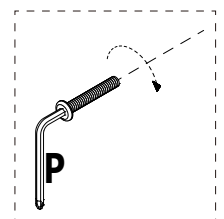
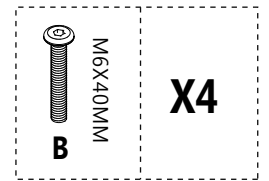
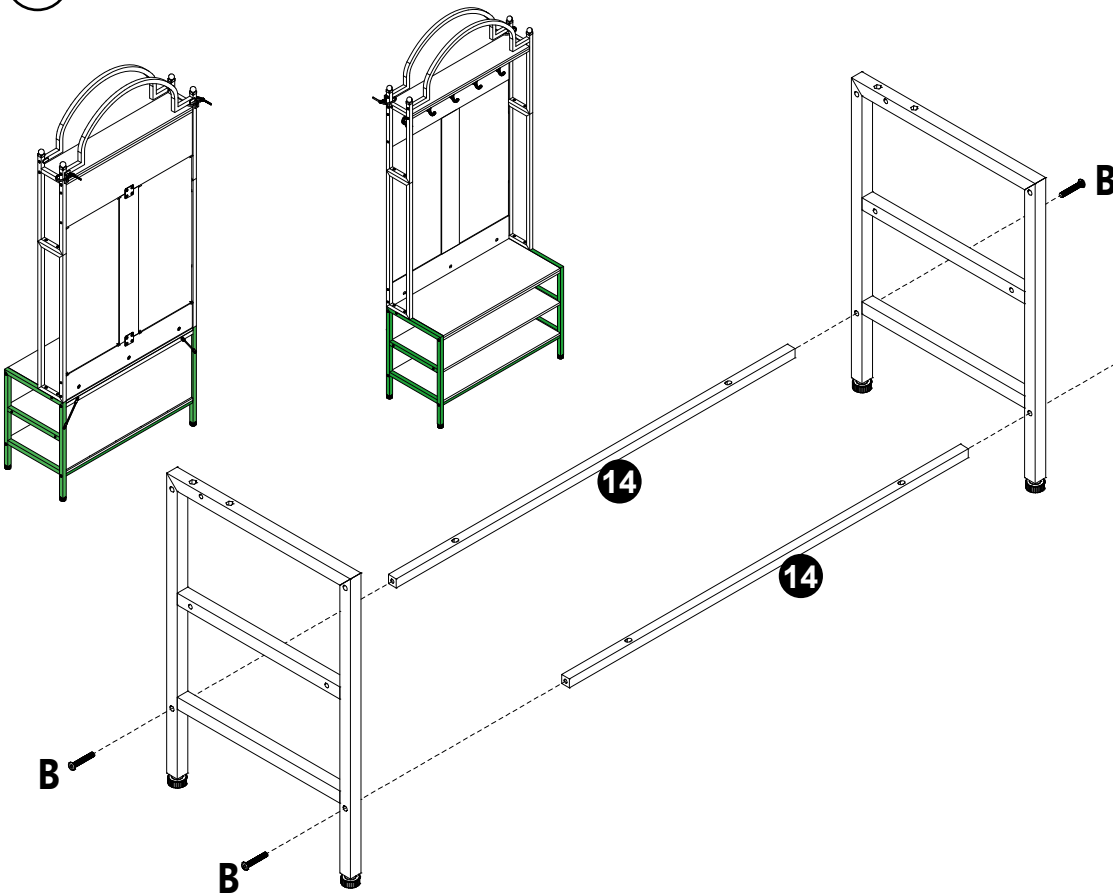
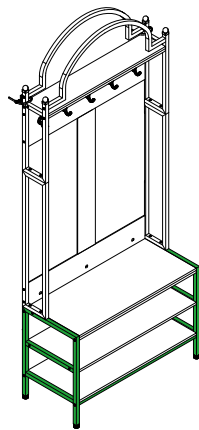
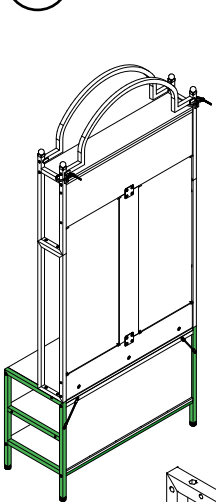

3

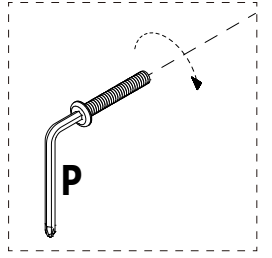
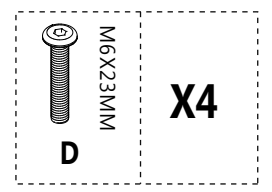
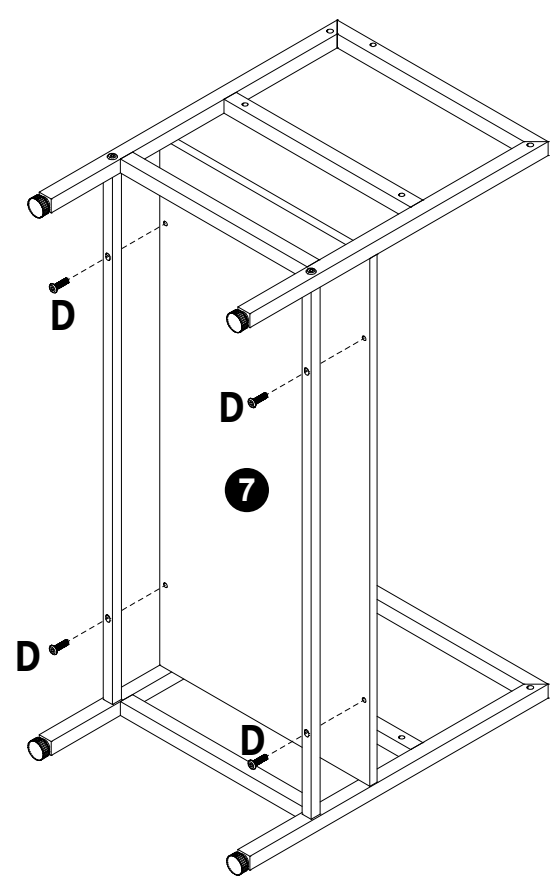
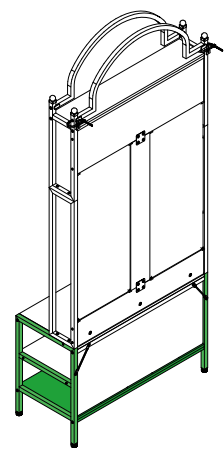
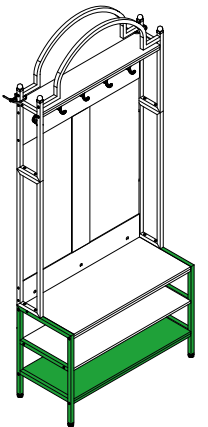

4

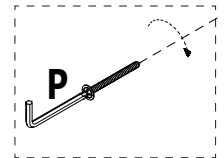
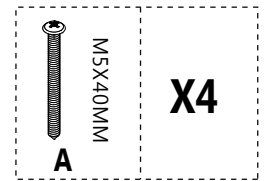
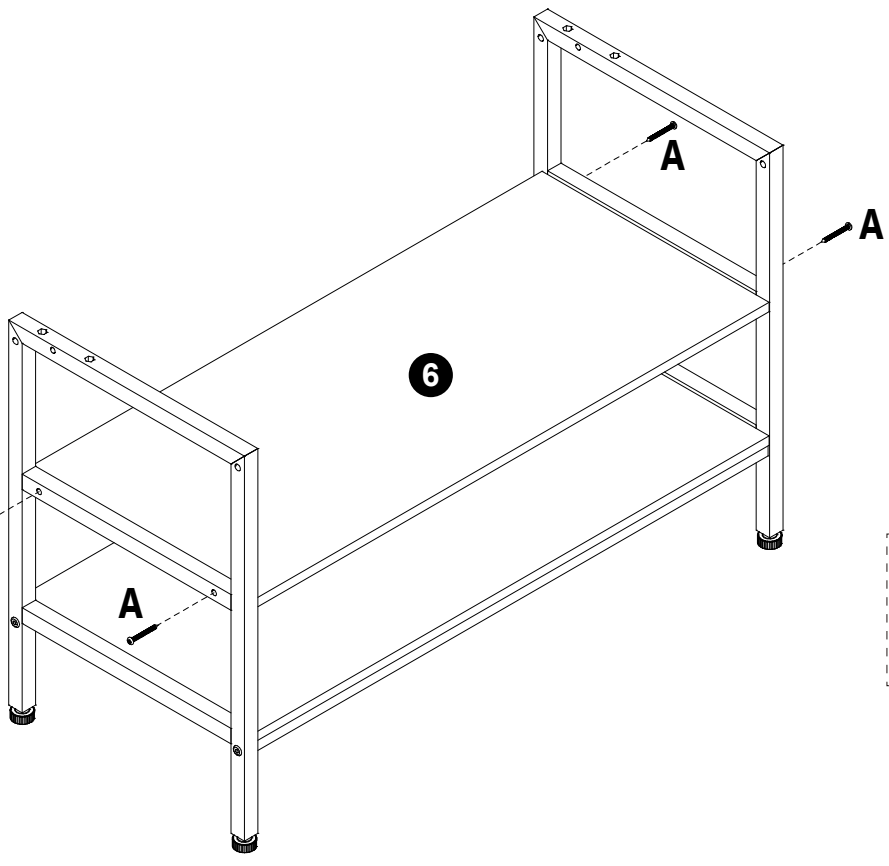
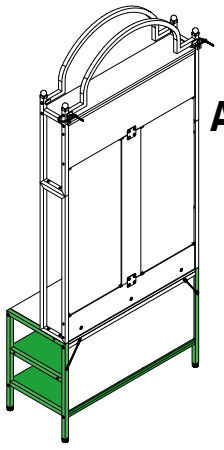
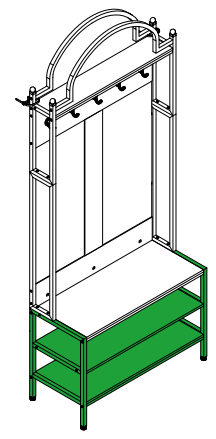

5

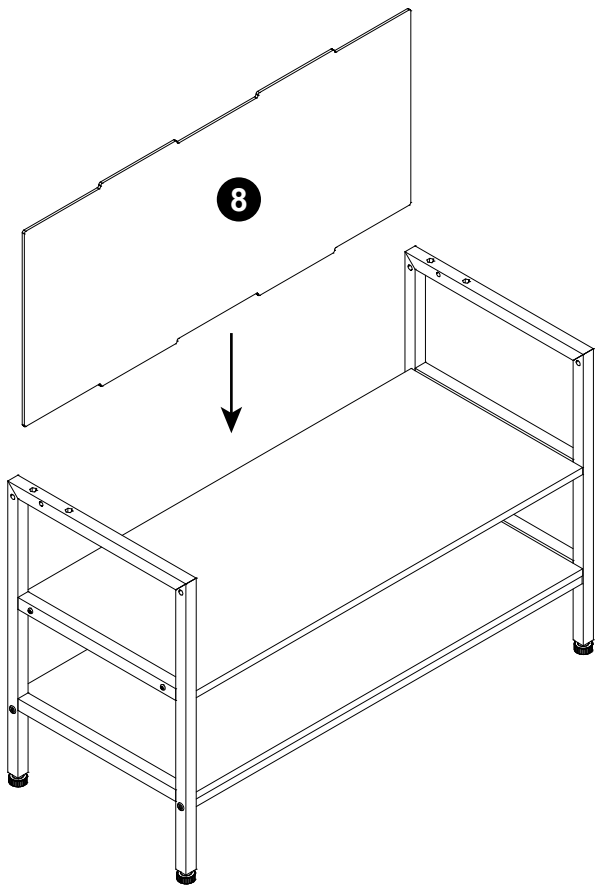
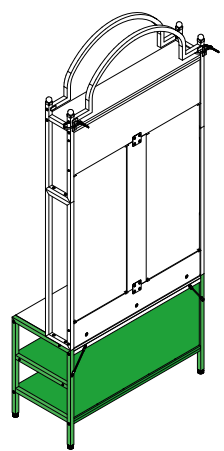
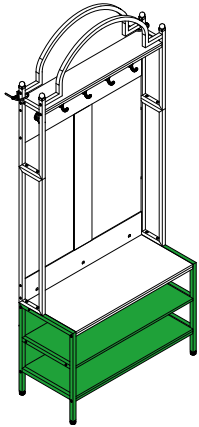

6

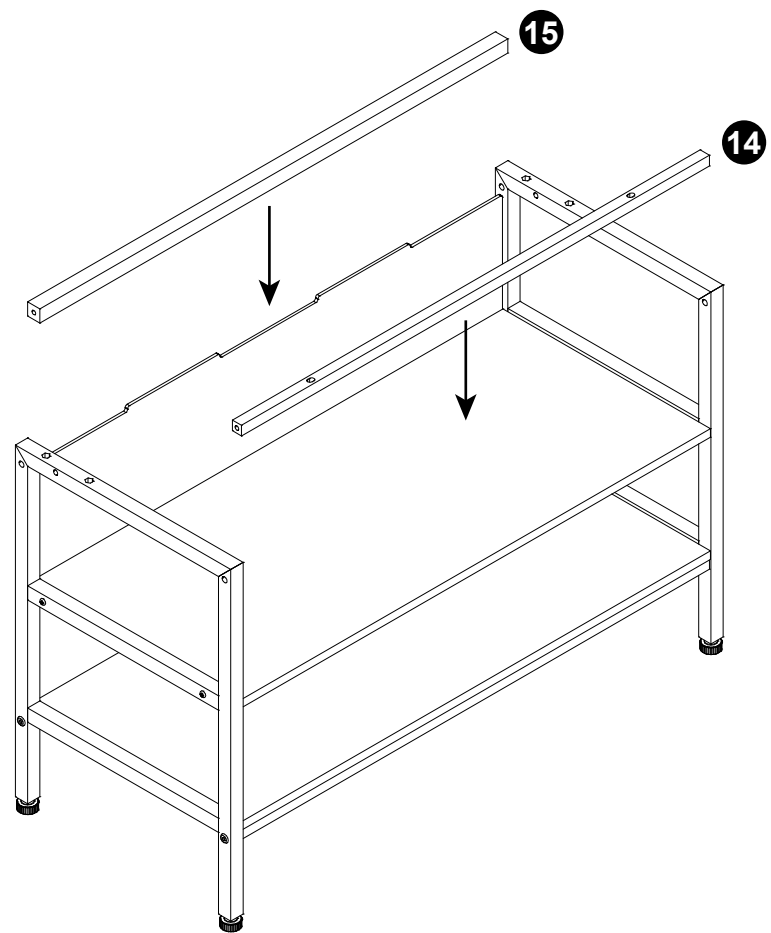
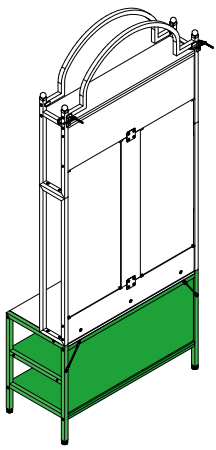
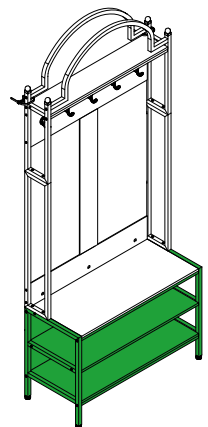

7

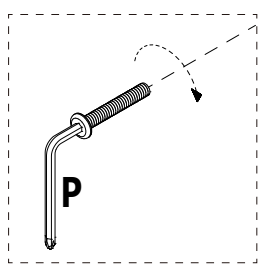
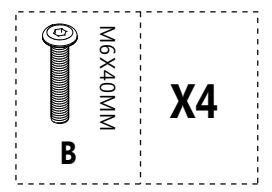
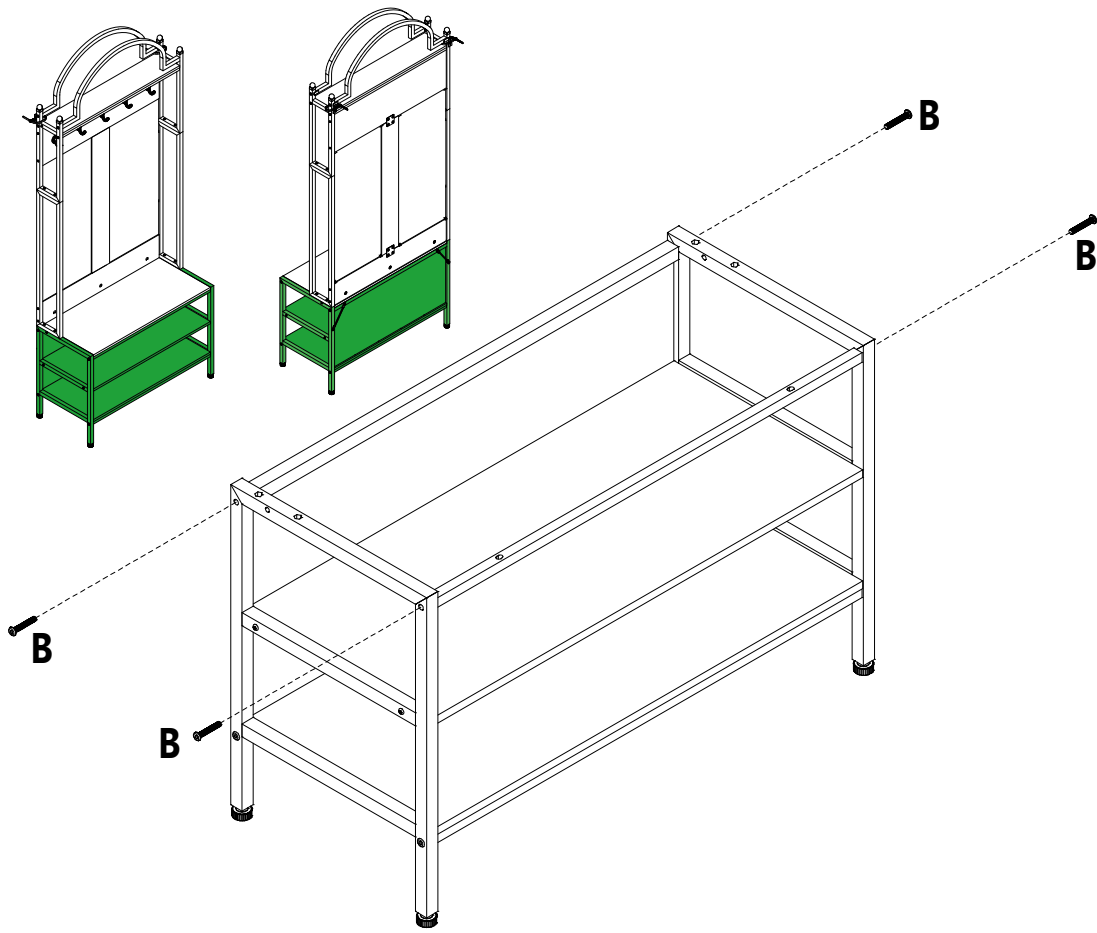

8

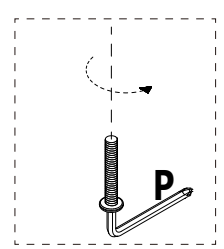
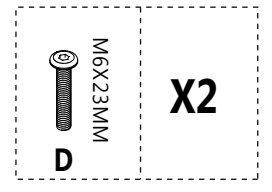
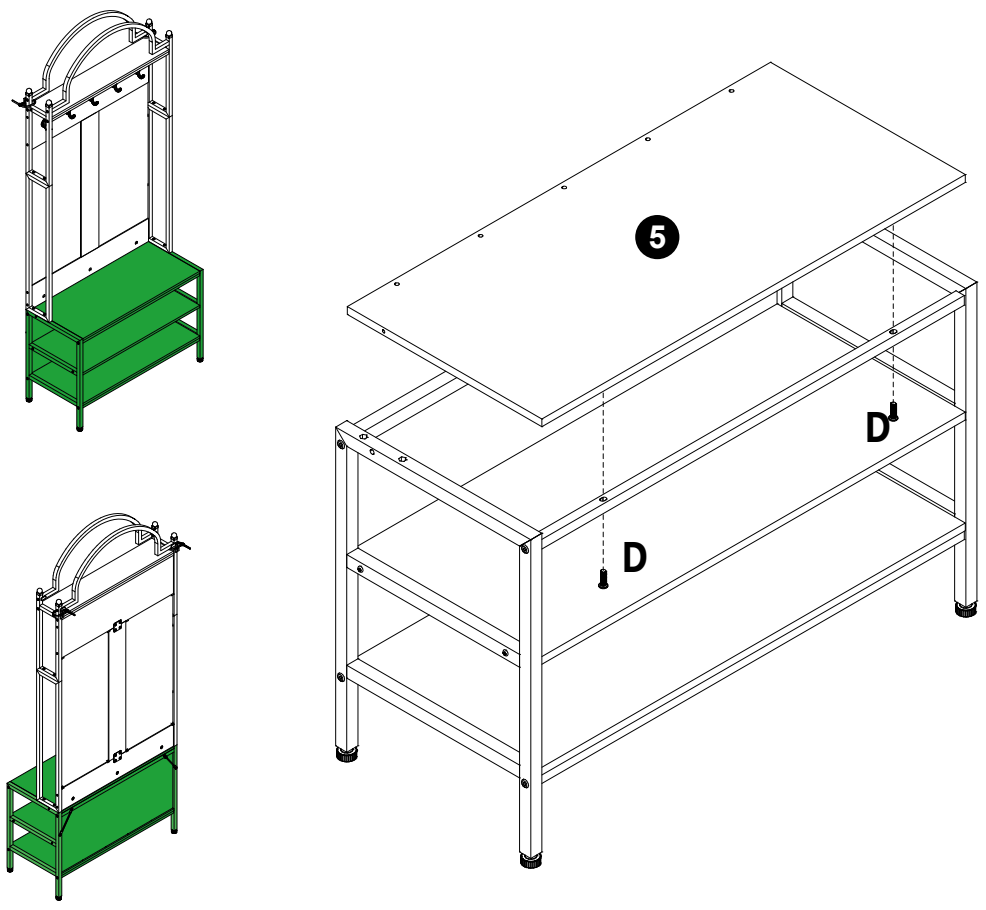

9

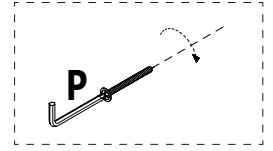
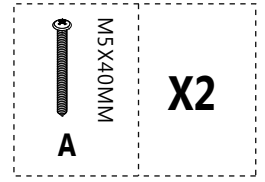
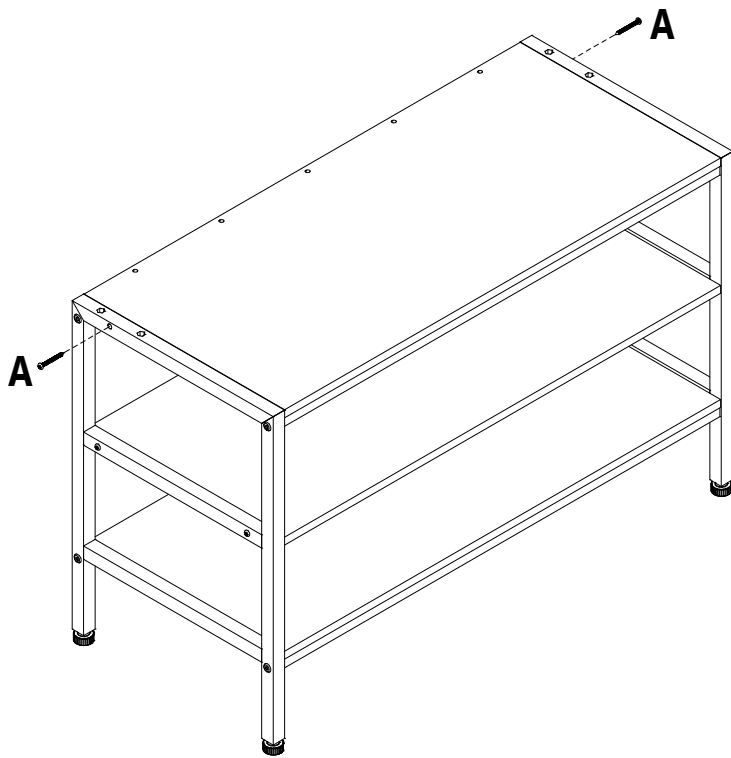
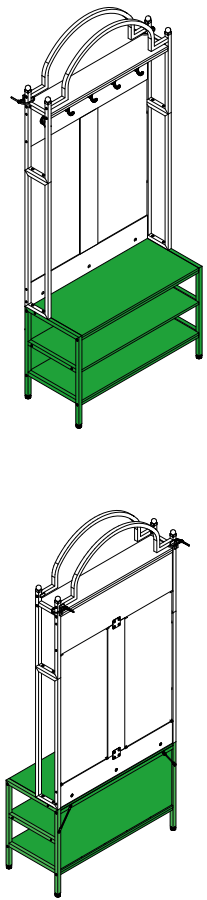

10

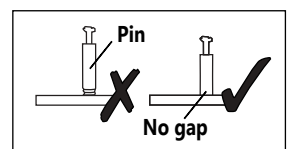
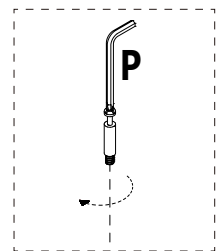
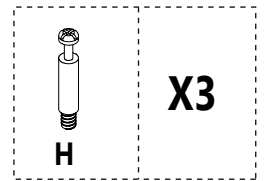
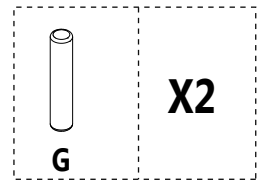
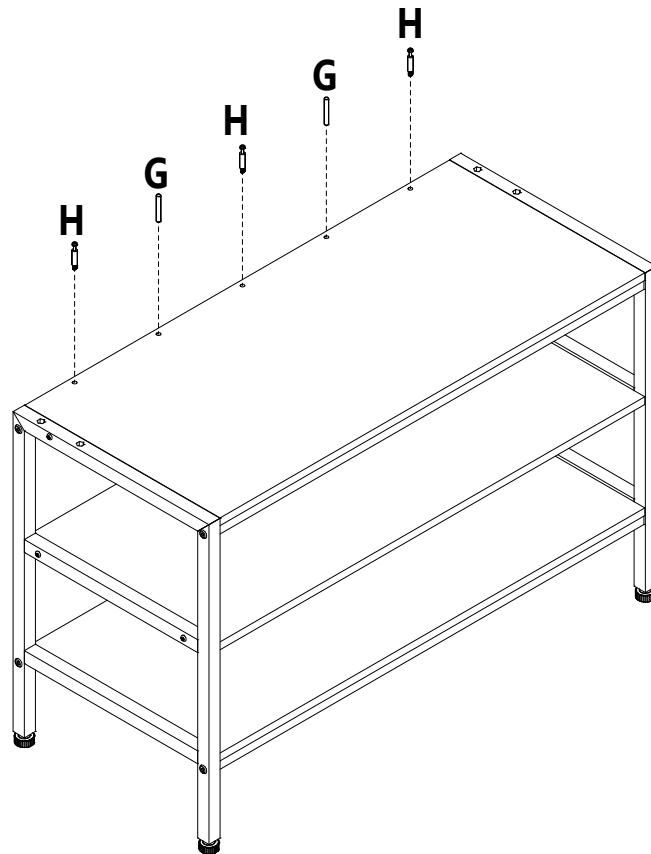
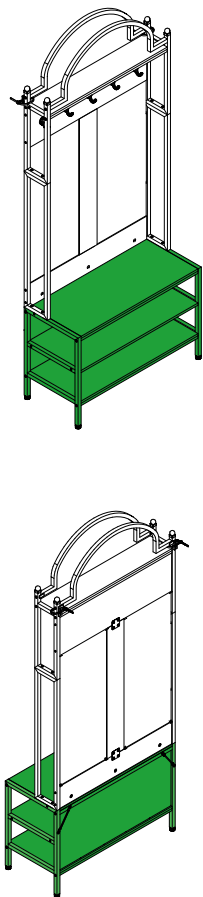

11

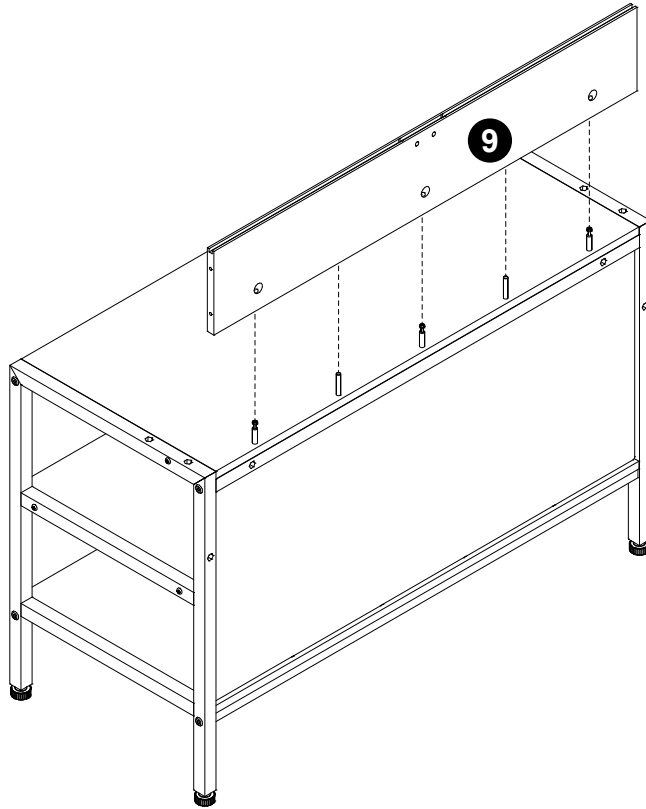
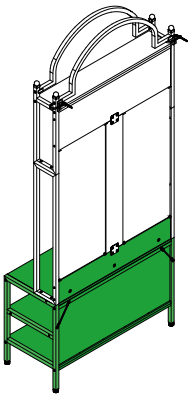
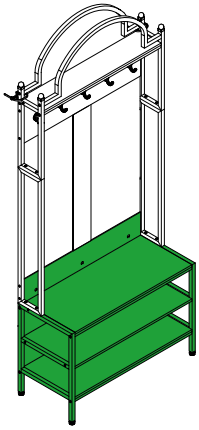

12

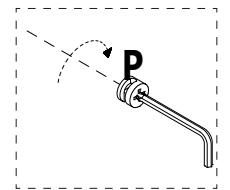
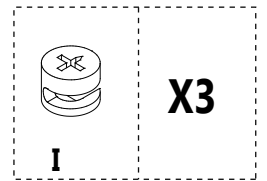
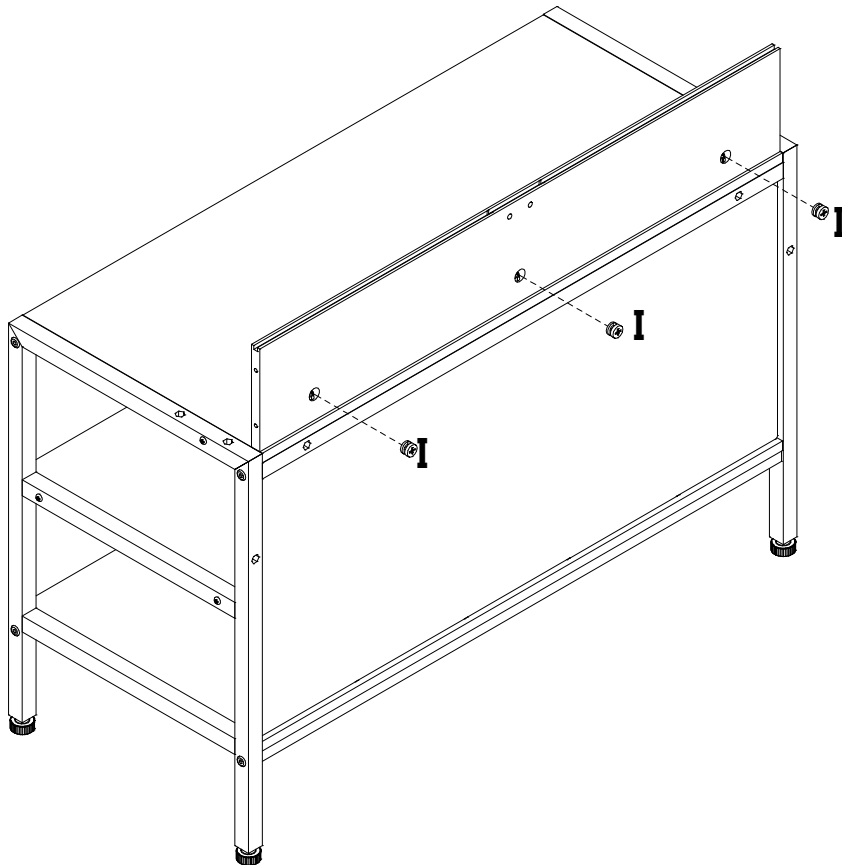
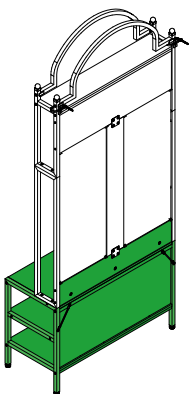
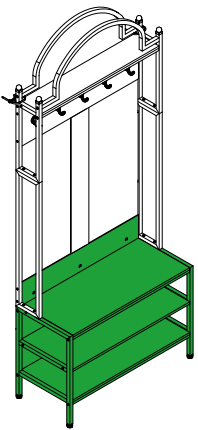

13

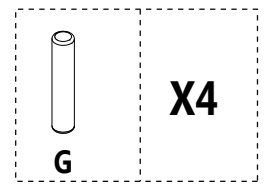
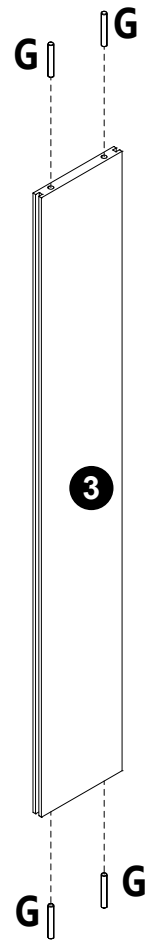
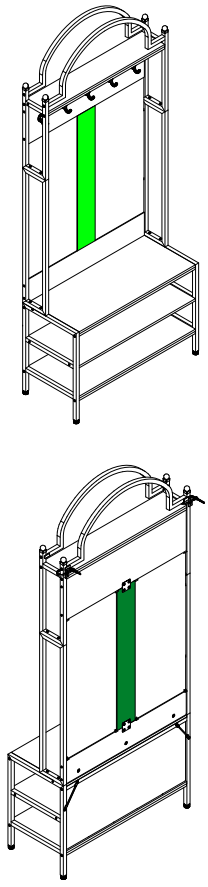

14

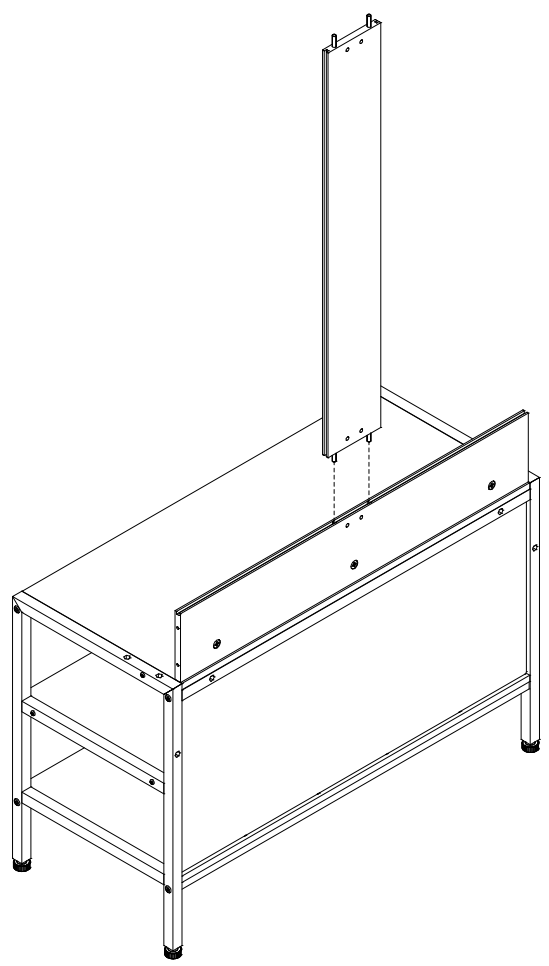
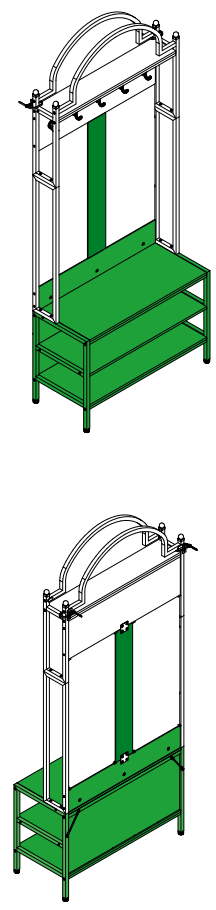

15

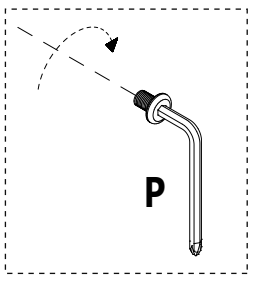
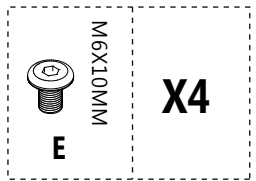
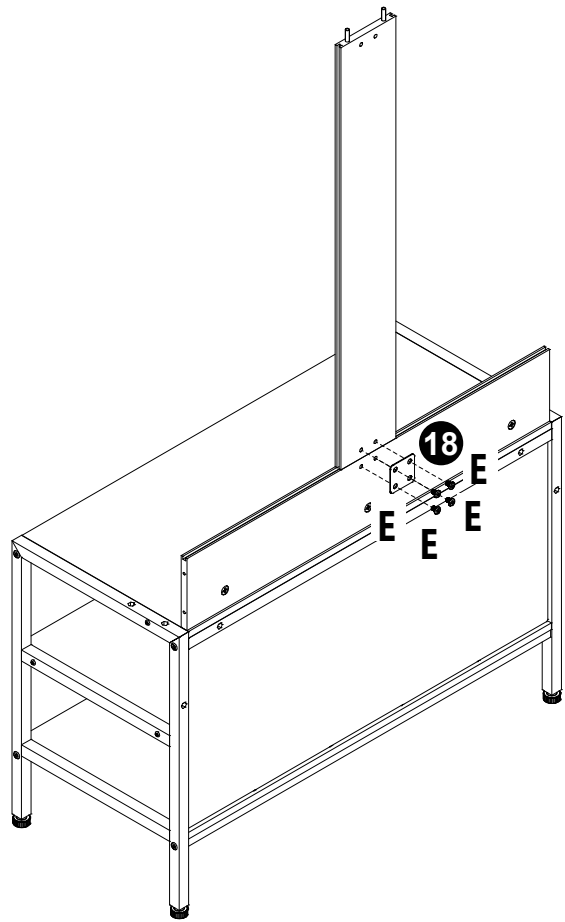
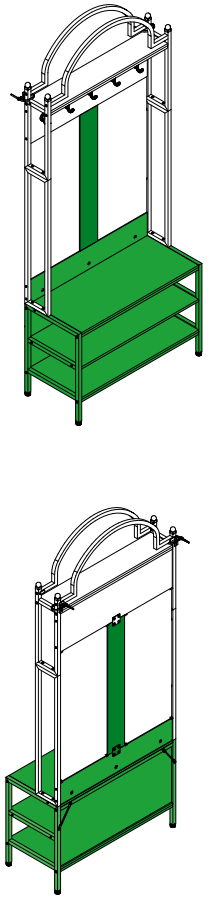

16

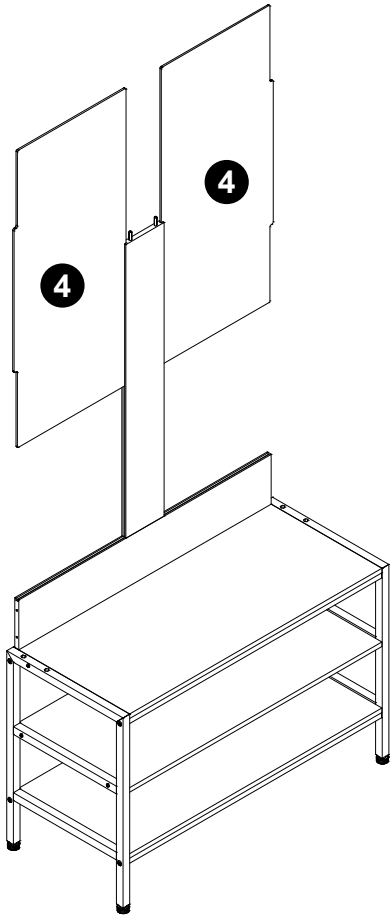
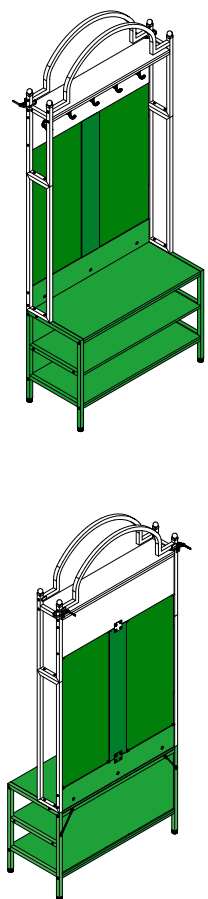

17

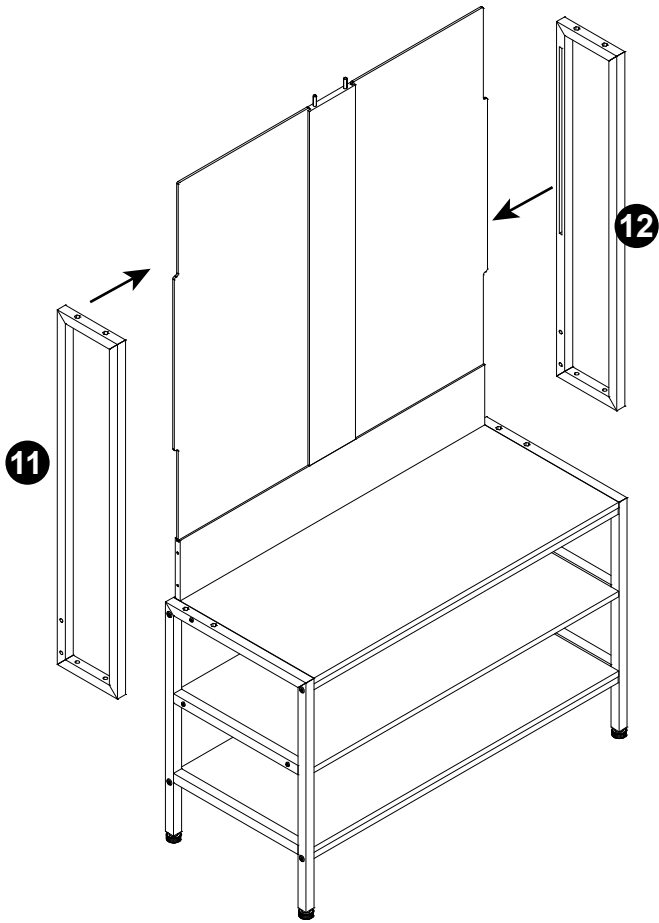
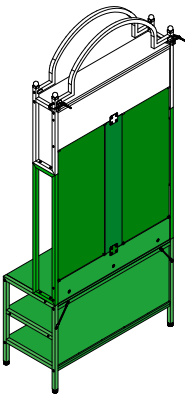
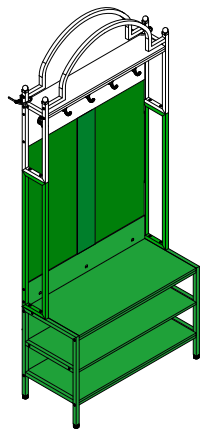

18

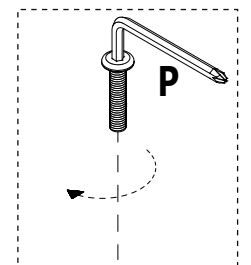
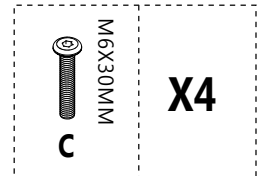
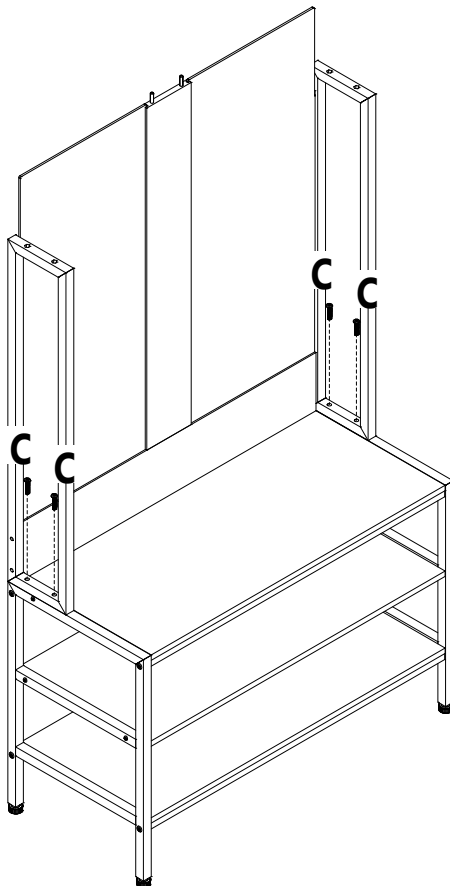
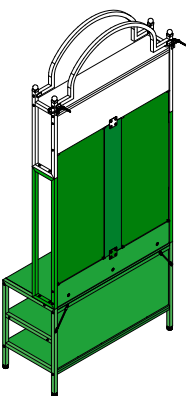
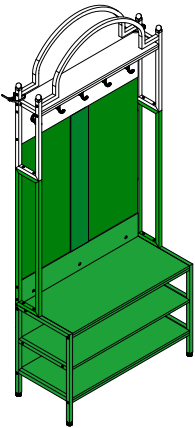

19

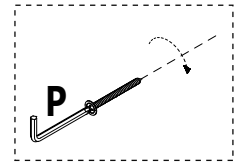
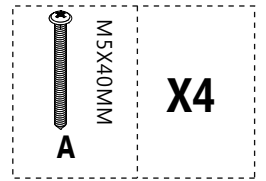
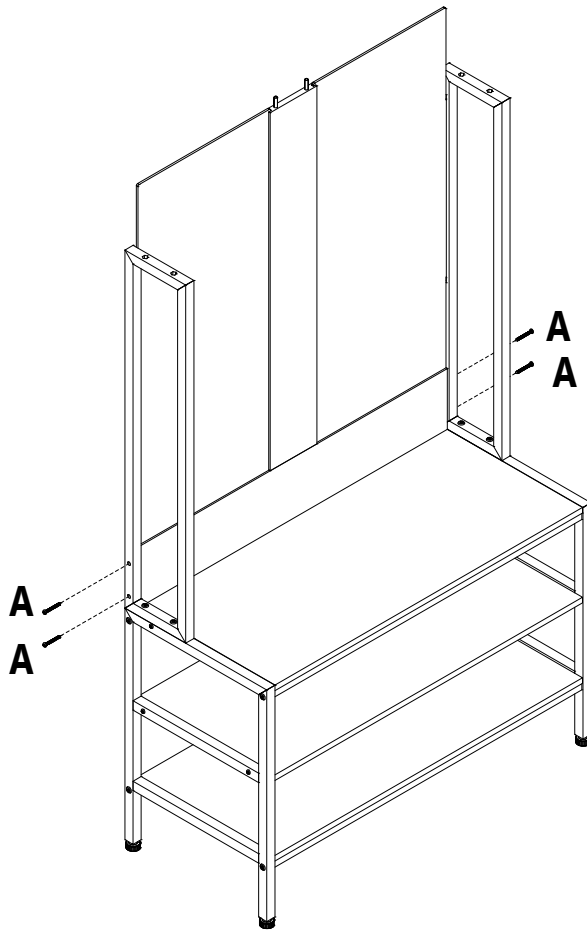
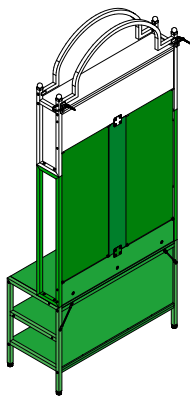
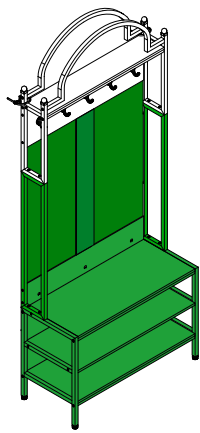

20

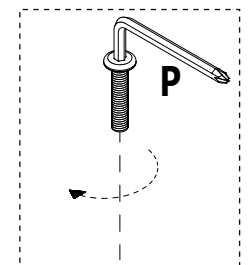
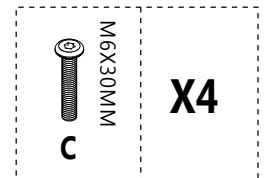
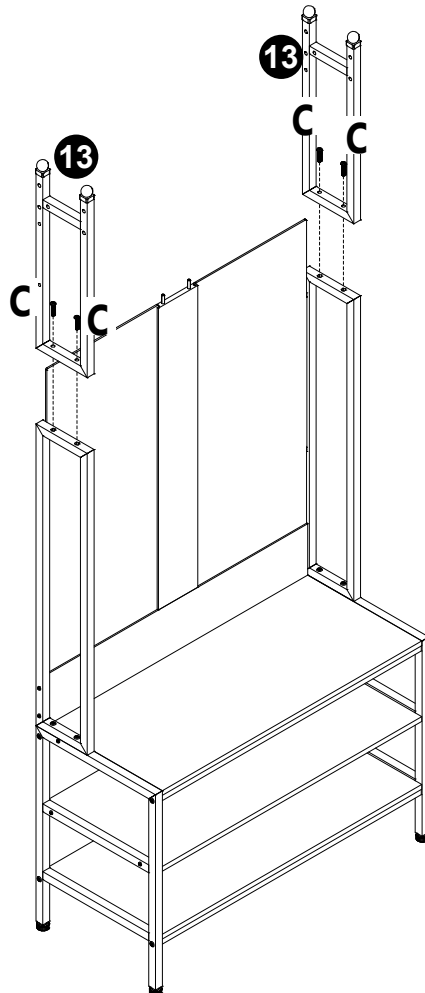
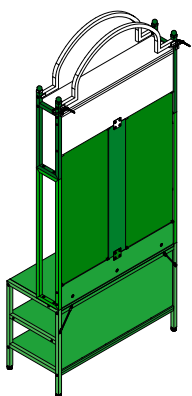
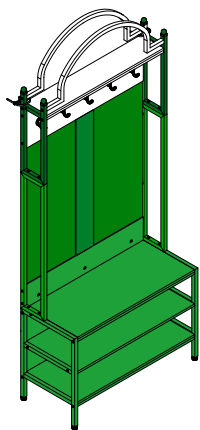

21

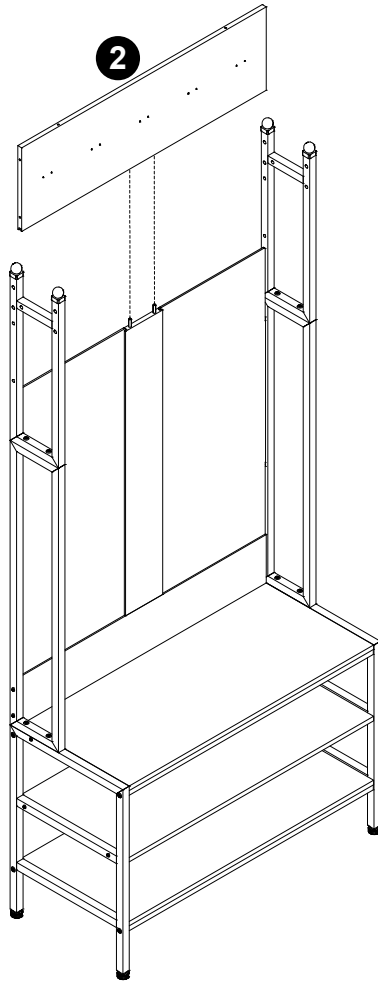
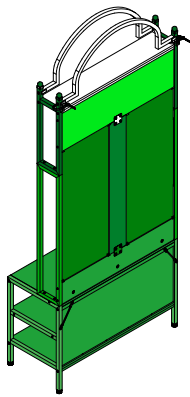
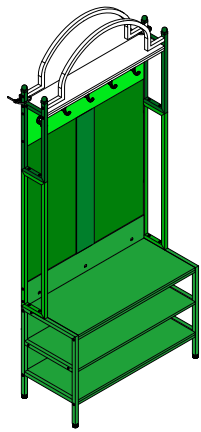

22

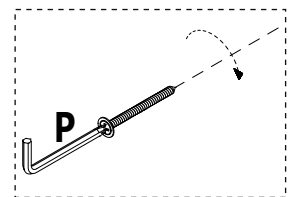
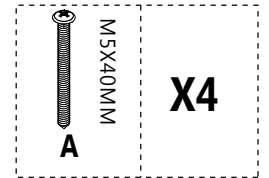
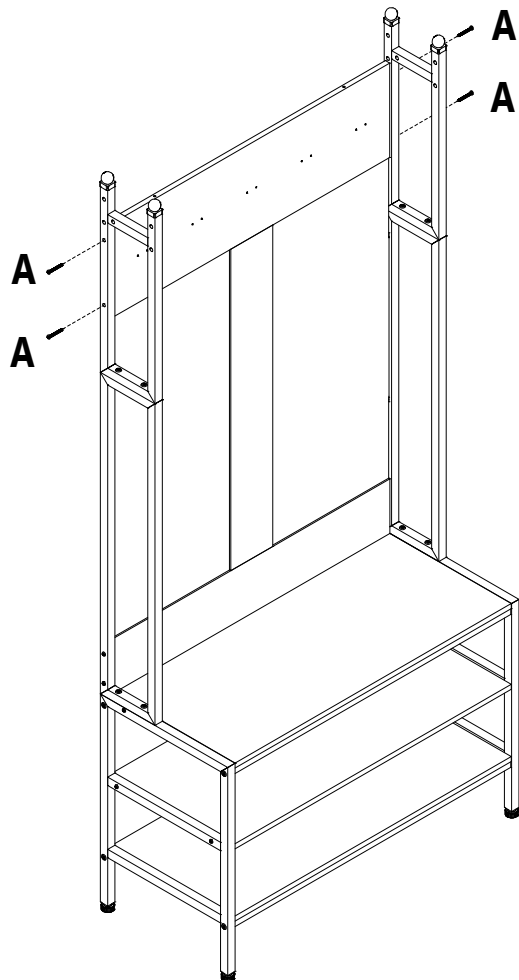
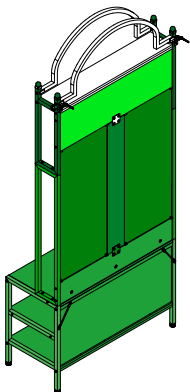
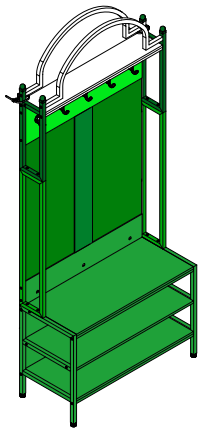

23

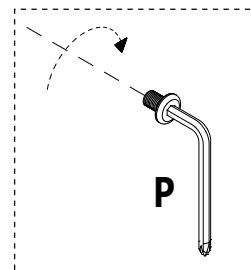
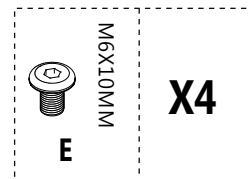
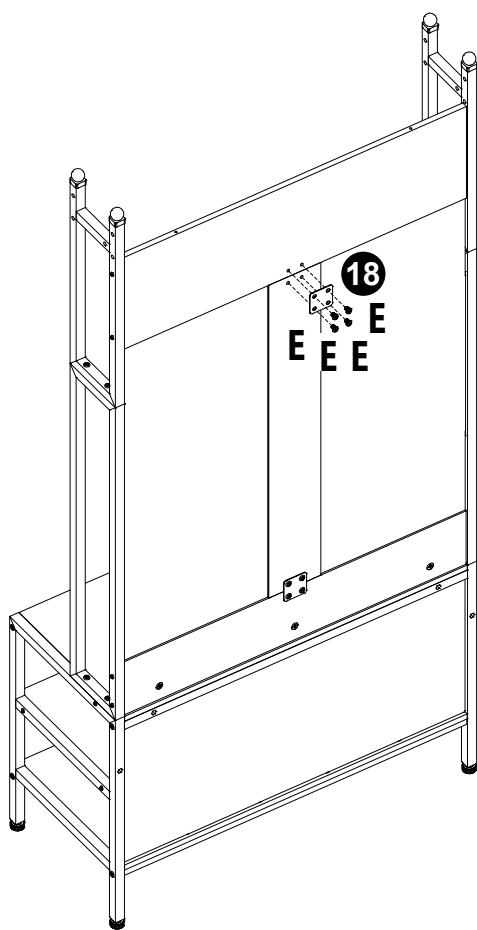
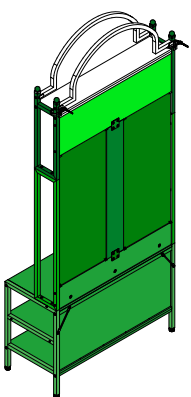
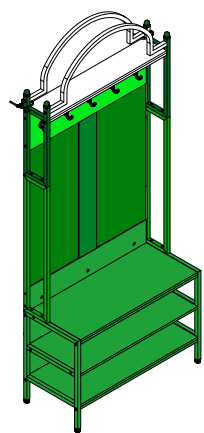

24

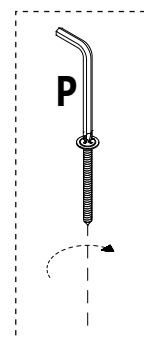
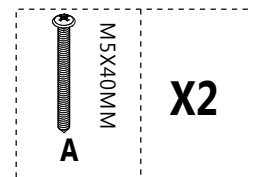
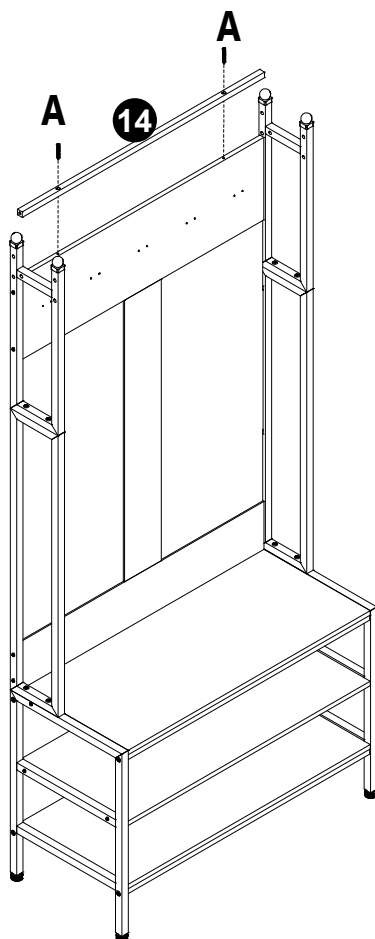
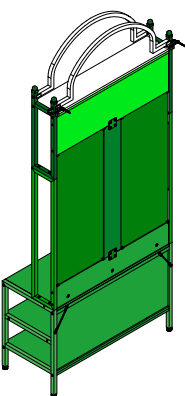
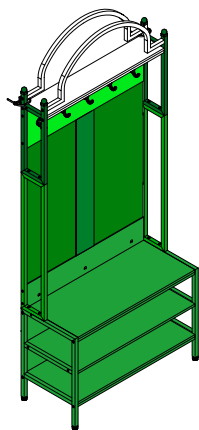

25

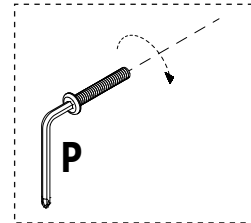
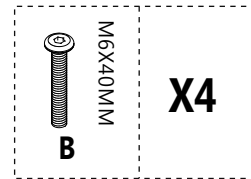
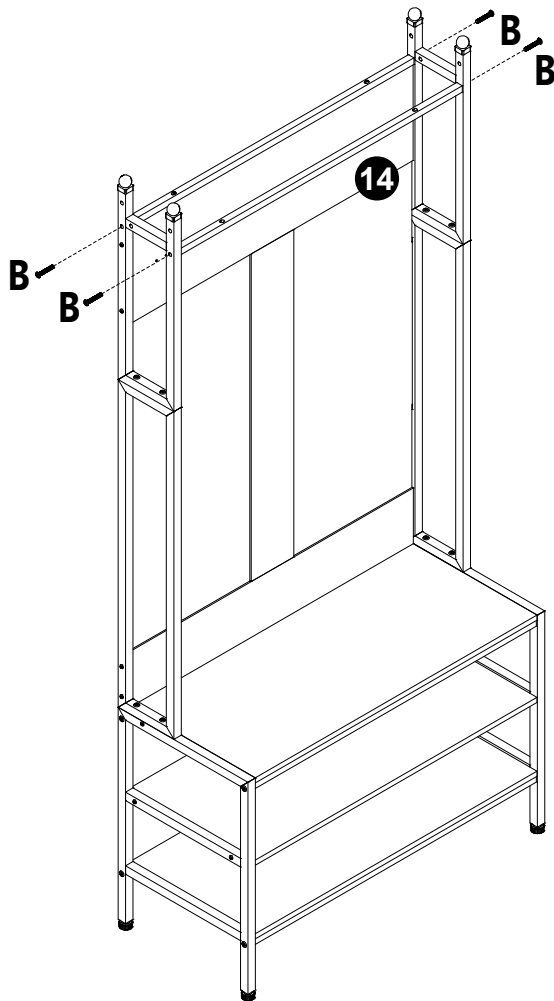
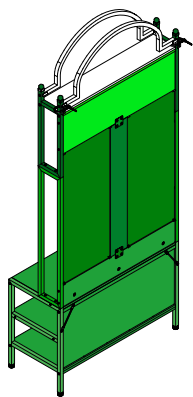
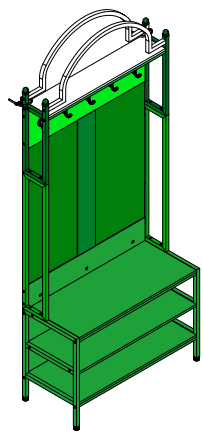

26

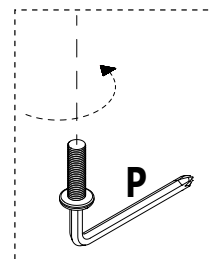
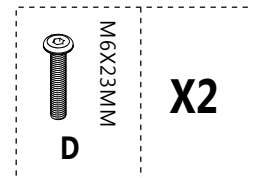
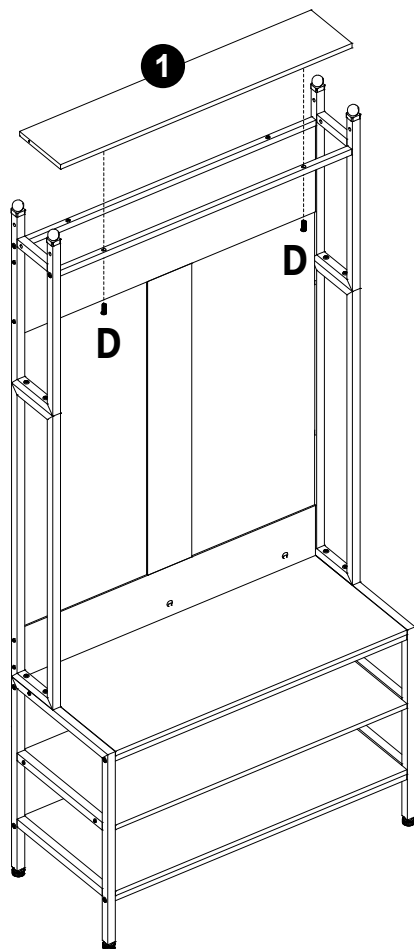
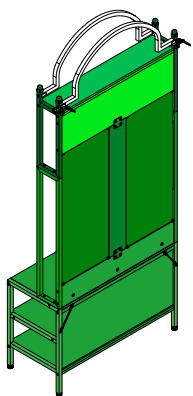
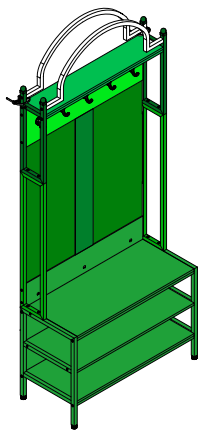

27

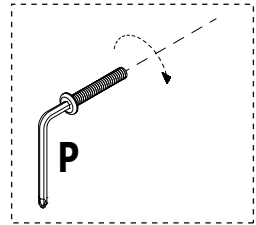
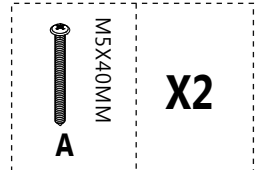
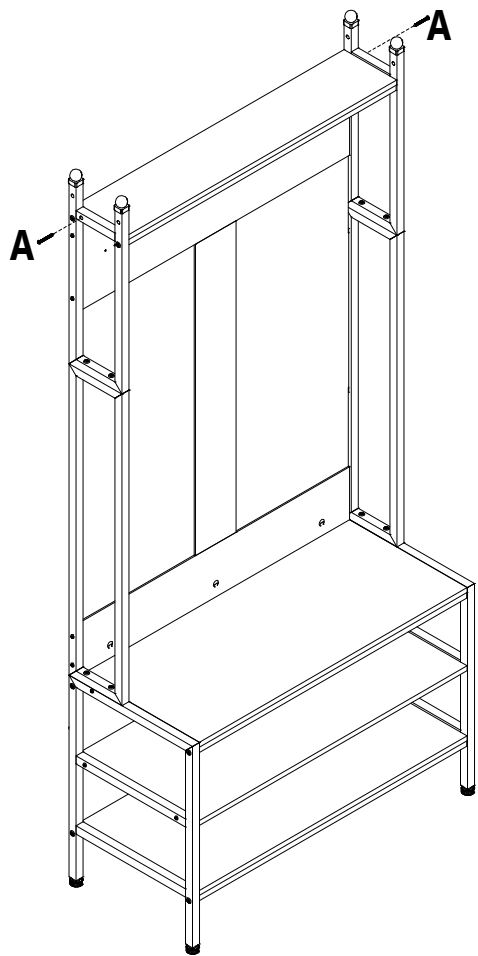
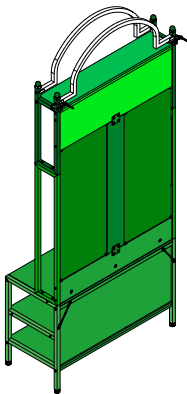
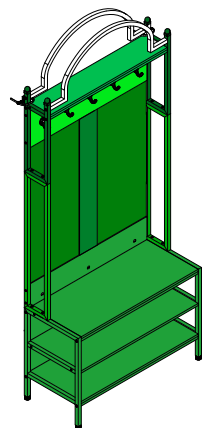

28

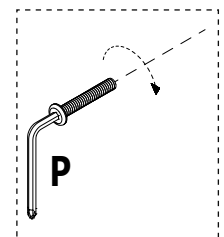
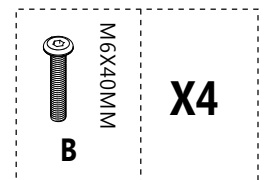
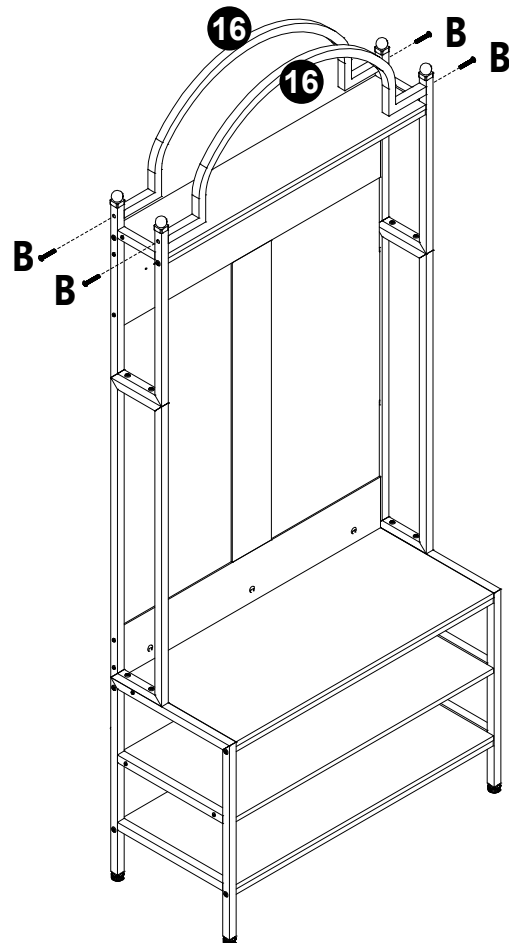
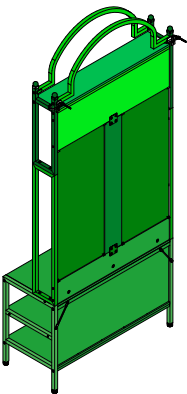
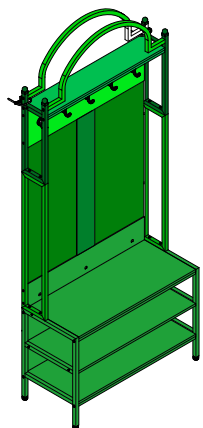

29

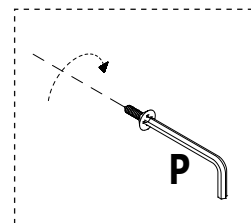
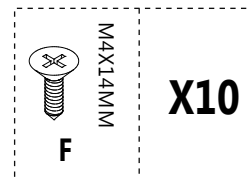
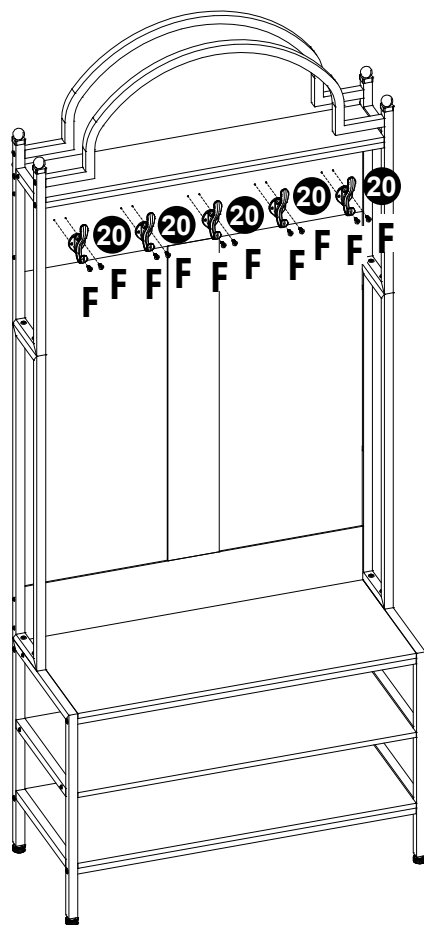

30

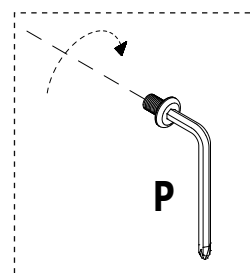
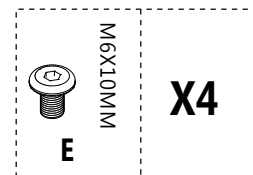
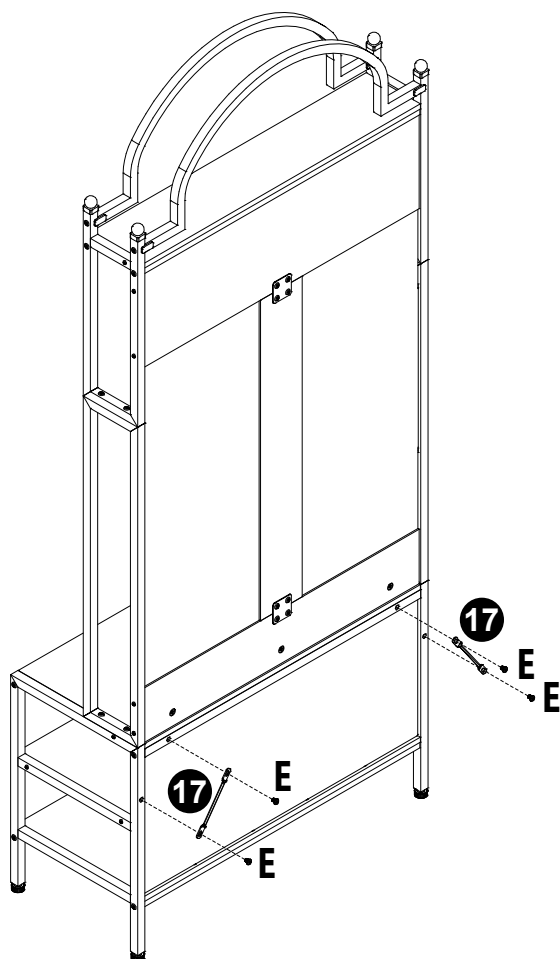

31

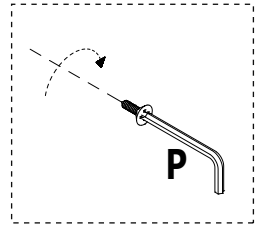
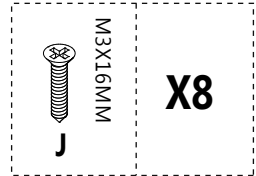
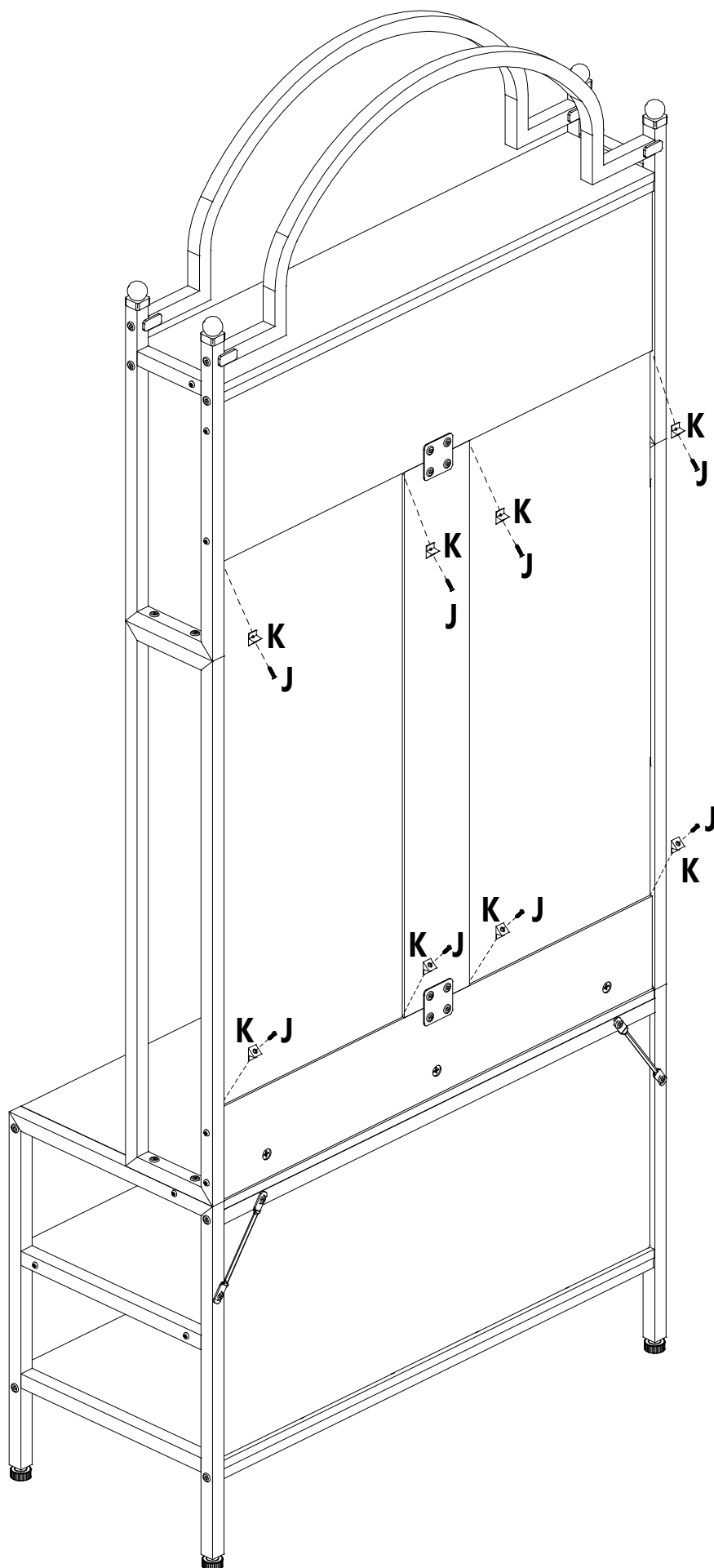

Give the same to the left

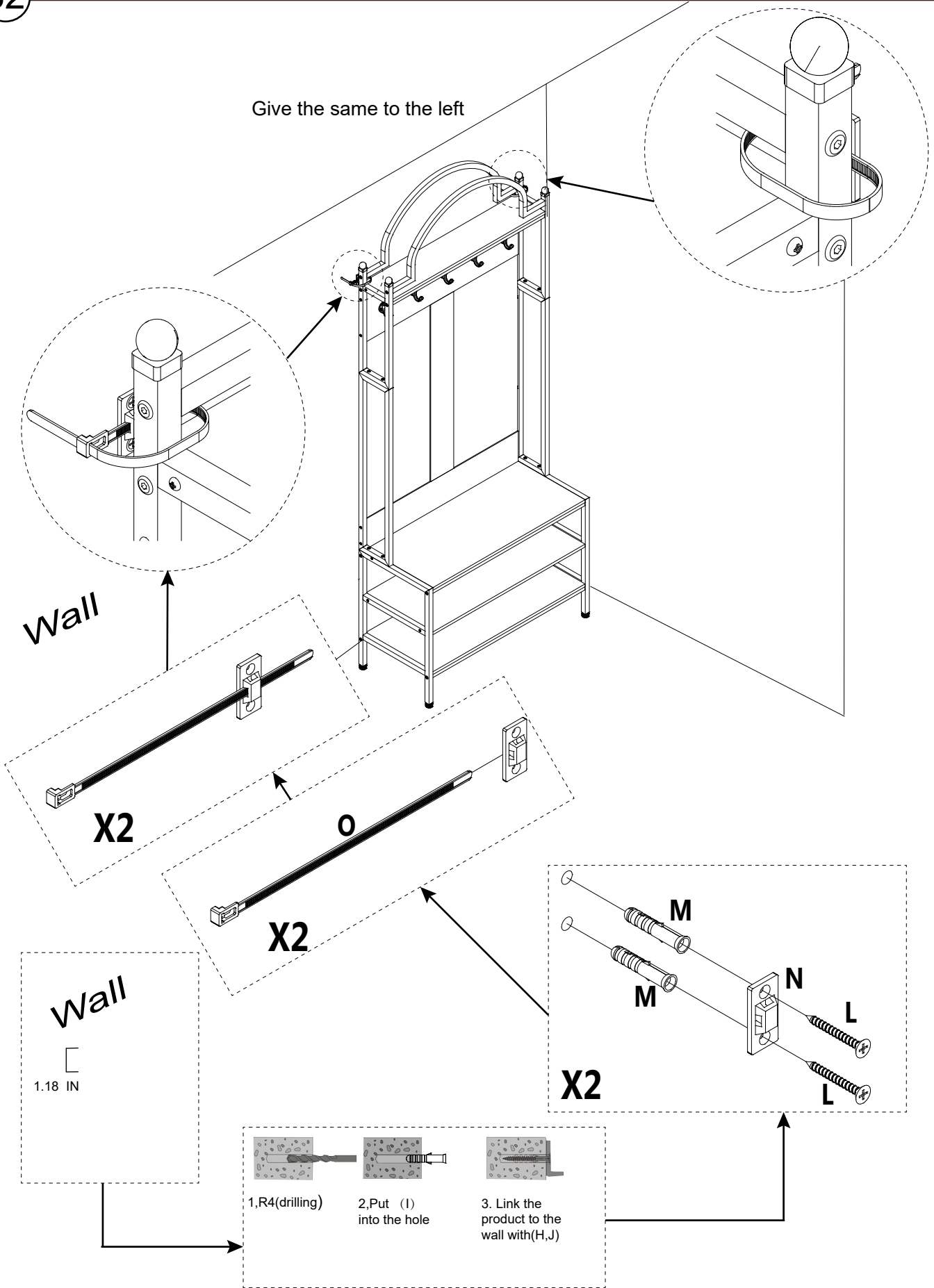

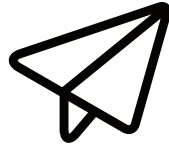

No heartburn, when we handle the return

Our way



YDS13538281408@163.com



Replacement/Refund



You

Their way



Re-package item



Schedule pick-up



Track package



Replacement



You

Contact our customer service team



YDS13538281408@163.com