

# ASSEMBLY INSTRUCTIONS

## LS REQUIRED:

Allen Wrench (Provided, Part F)  
Phillips Screw Driver (Not Provided)

## BEFORE YOU START:

1. Check the hardware against the hardware list to make sure all items are present.
2. Assemble your furniture on a soft, flat surface to avoid scratching the finish.
3. CAUTION: Do not over tighten screws, nuts or bolts during assembly.
4. Your furniture may require occasional tightening.

## INSTRUCTIONS:

1. Turn the table on to a clean soft surface .
2. Attach bottom shelf to the legs using Bolt (B), Lock Washer(C), Flat Washer (D) and tighten all bolts using Allen Wrench (F).As shown in Figure 1 .
3. Attach the Casters (G) to the bottom shelf using Screw (E).As shown in Figure 2 .
4. Attach the legs to the top using Bolt (A), Lock Washer (C), Flat Washer (D) and tighten all bolts using Allen Wrench (F).As shown in Figure 3 .
5. Tighten all bolts before setting table back up right .

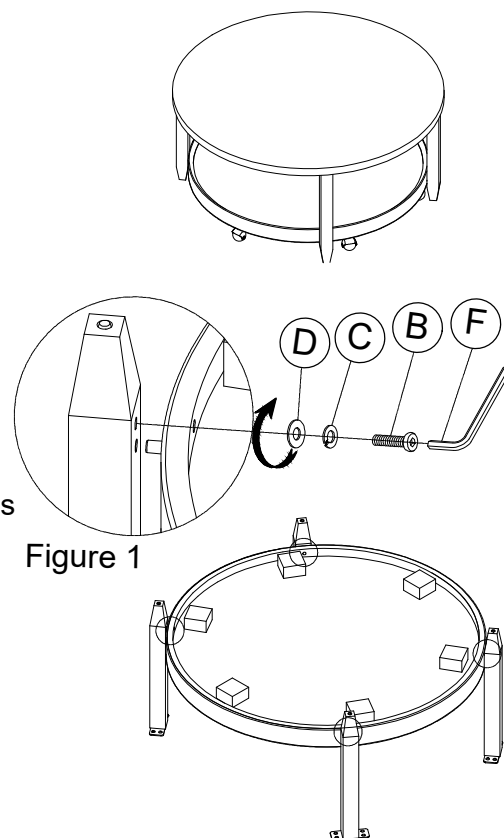

Figure 1

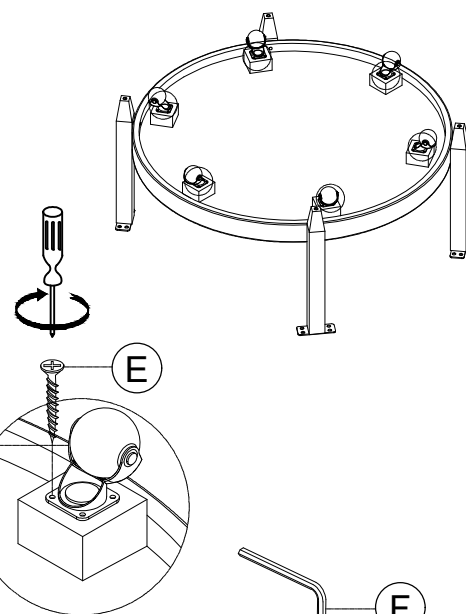

Figure 2

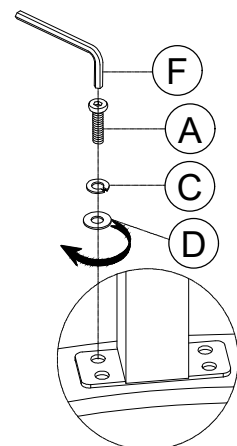









Figure 3

HARDWARE LIST			
A		Ø1/4"x1" Bolt	16pcs
B		Ø1/4"x1-1/2" Bolt	4pcs
C		Ø1/4"x13mm Lock Washer	20pcs
D		Ø1/4" x19mm Flat Washer	20pcs
E		Ø1/4"x3/4"Screw	24pcs
F		1/4"x100mm Allen Wrench	1pc
G		Castors (55x64x64mm)	6pcs