

Assembly Instructions

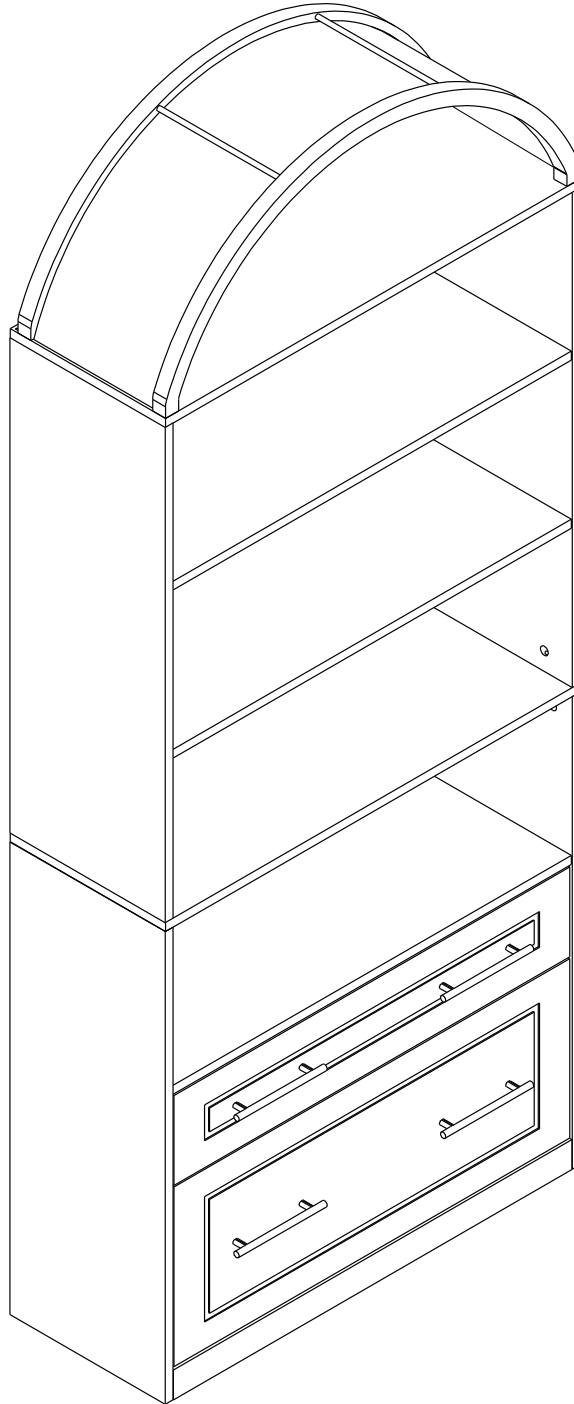

Bookcase

Model No.
HOGA-J0386

Contact Us

We're here to help you.

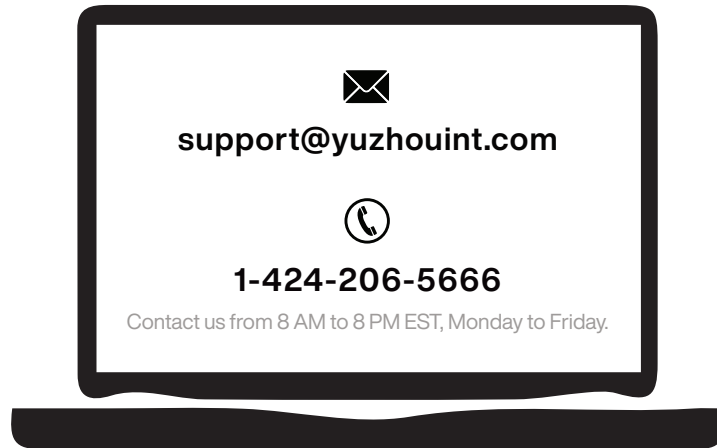

Your satisfaction is our top priority. If you encounter any issues with this product, such as missing or damaged parts, we're here to help. Please retain the original packaging and take photos of the packaging and the product, then contact us as soon as possible.

Warm Tips

1. Carefully read these instructions and keep them for future reference.
2. Check the parts list and confirm everything's there before starting assembly.
3. When assembling, put all parts on a soft, smooth surface like a carpet to avoid scratches.
4. Don't fully tighten screws until all parts are confirmed in place to avoid misalignment.

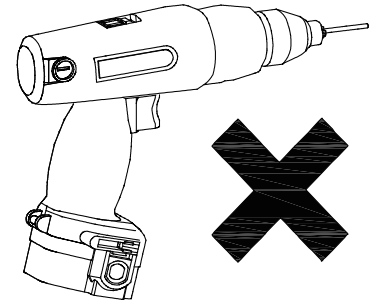
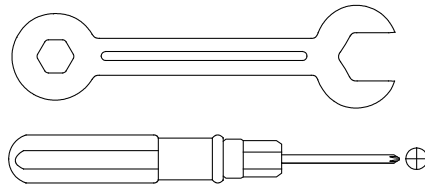
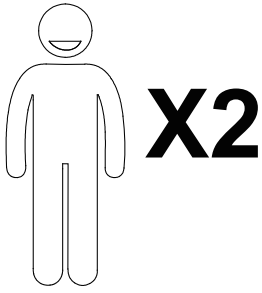

We recommend using hand tools for assembly.

If an electric screwdriver is used, reduce power and torque to avoid damage to the product.

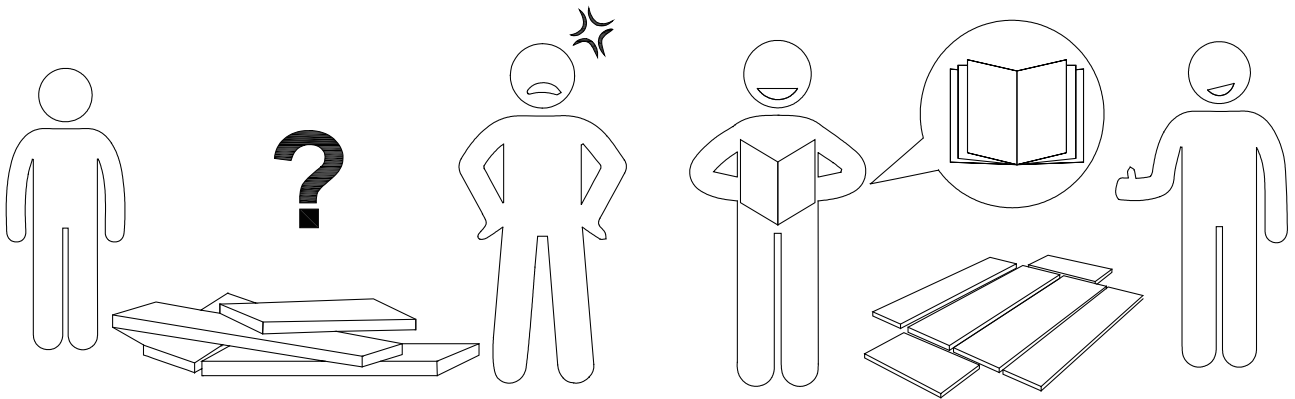

Install the Anti-Tip Straps

Using the anti-tip straps can reduce the risk of tipping over, but can not eliminate it.

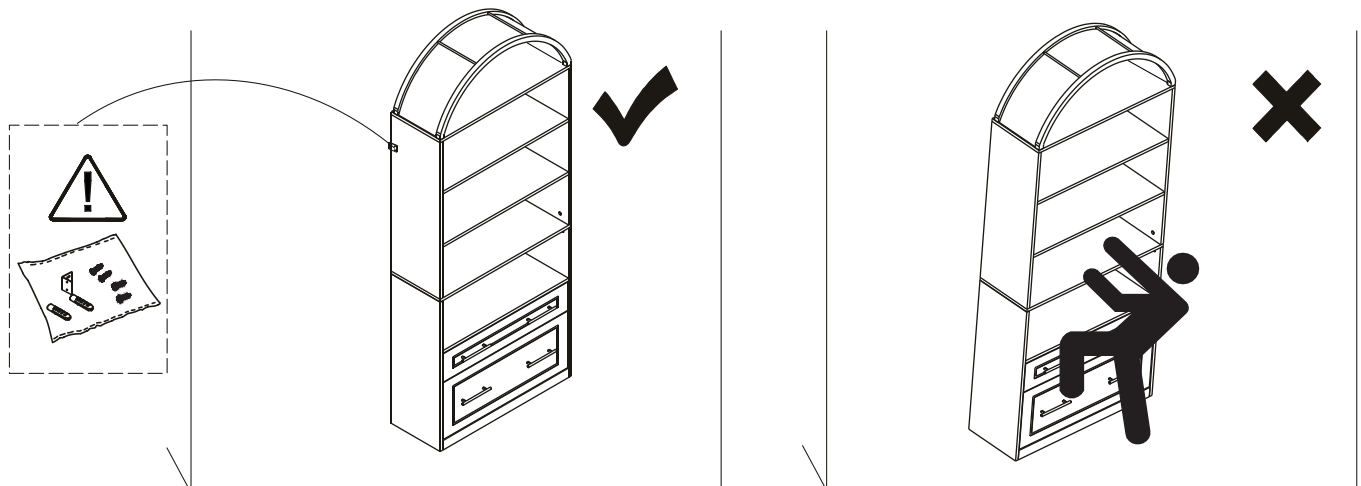

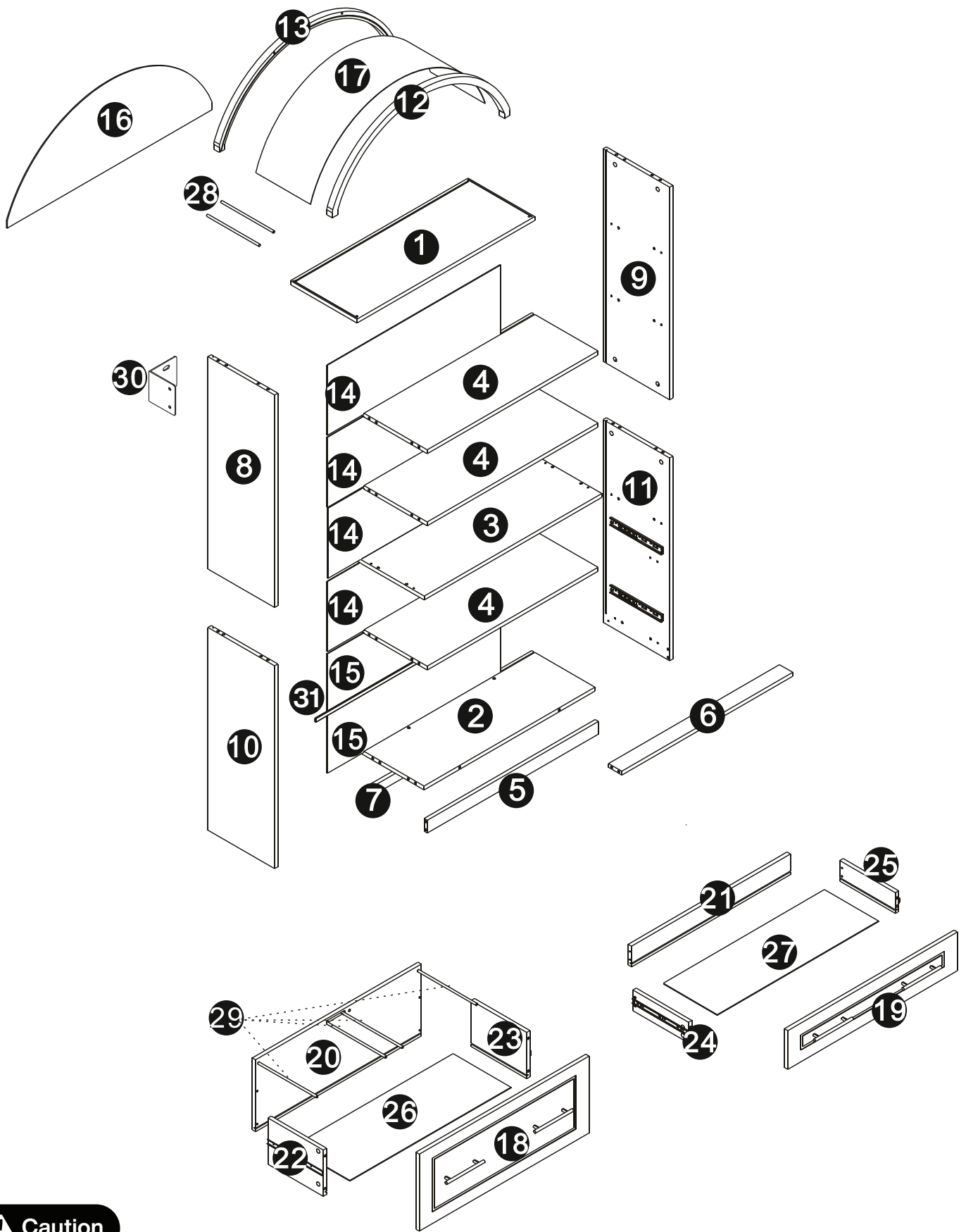







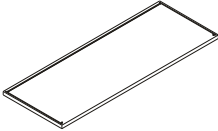
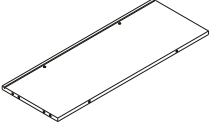
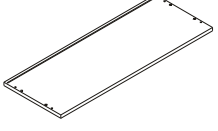
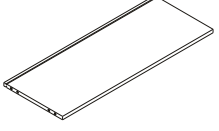
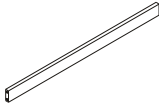
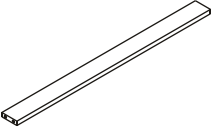
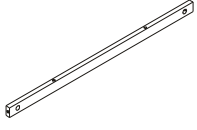

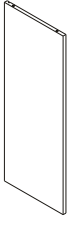

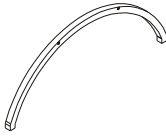
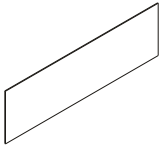
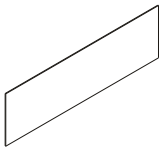
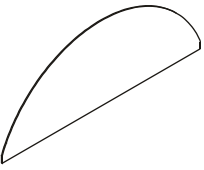
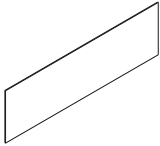
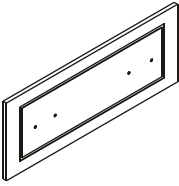
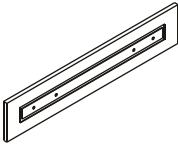
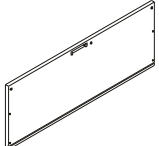
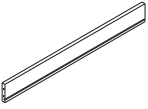
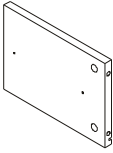
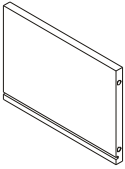
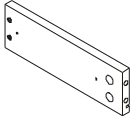
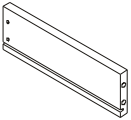
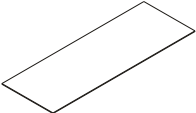
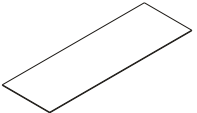
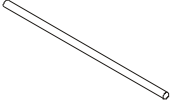
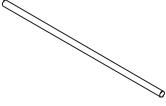
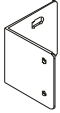

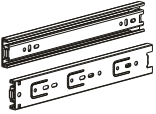





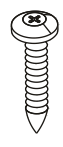

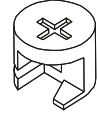
⚠ Caution

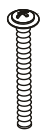
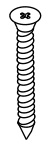
Make sure all parts are included. Most board parts are labeled or stamped on the raw edge. Contact us for a free replacement if you encounter any damaged or missing parts.

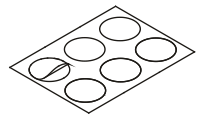
Parts List

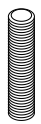
<p>1</p>  <p>1 pc</p>	<p>2</p>  <p>1 pc</p>	<p>3</p>  <p>1 pc</p>	<p>4</p>  <p>3 pcs</p>	<p>5</p>  <p>1 pc</p>
<p>6</p>  <p>1 pc</p>	<p>7</p>  <p>1 pc</p>	<p>8</p>  <p>1 pc</p>	<p>9</p>  <p>1 pc</p>	<p>10</p>  <p>1 pc</p>
<p>11</p>  <p>1 pc</p>	<p>12</p>  <p>1 pc</p>	<p>13</p>  <p>1 pc</p>	<p>14</p>  <p>4 pcs</p>	<p>15</p>  <p>2 pcs</p>
<p>16</p>  <p>1 pc</p>	<p>17</p>  <p>1 pc</p>	<p>18</p>  <p>1 pc</p>	<p>19</p>  <p>1 pc</p>	<p>20</p>  <p>1 pc</p>
<p>21</p>  <p>1 pc</p>	<p>22</p>  <p>1 pc</p>	<p>23</p>  <p>1 pc</p>	<p>24</p>  <p>1 pc</p>	<p>25</p>  <p>1 pc</p>
<p>26</p>  <p>1 pc</p>	<p>27</p>  <p>1 pc</p>	<p>28</p>  <p>2 pcs</p>	<p>29</p>  <p>4 pcs</p>	<p>30</p>  <p>1 pc</p>
<p>31</p>  <p>1 pc</p>	<p>32</p>  <p>10" 2Sets</p>			

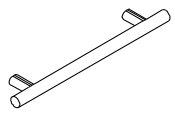
Hardware List

A	B	C	D	E	F
					
M5x38mm	M4x24.5mm	M3.5x14mm	M6x44.5mm	Ø15mm	Ø8X30mm
6 pcs	2 pcs	52 pcs	44 pcs	44 pcs	32 pcs
G	H	I	J	K	L
					
M4x35mm	M4x35mm		Ø21mm		M4x20mm
2 pcs	8 pcs	30 pcs	24 pc	2 pcs	2 pcs
M	N	O			
					
M4X18mm					
8 pc	4 pcs	1 pc			

Installation of Cams and Pins

Read each step carefully before starting. Each step of instruction should be performed in the correct order. If these steps are not followed in sequence, assembly difficulties may occur.

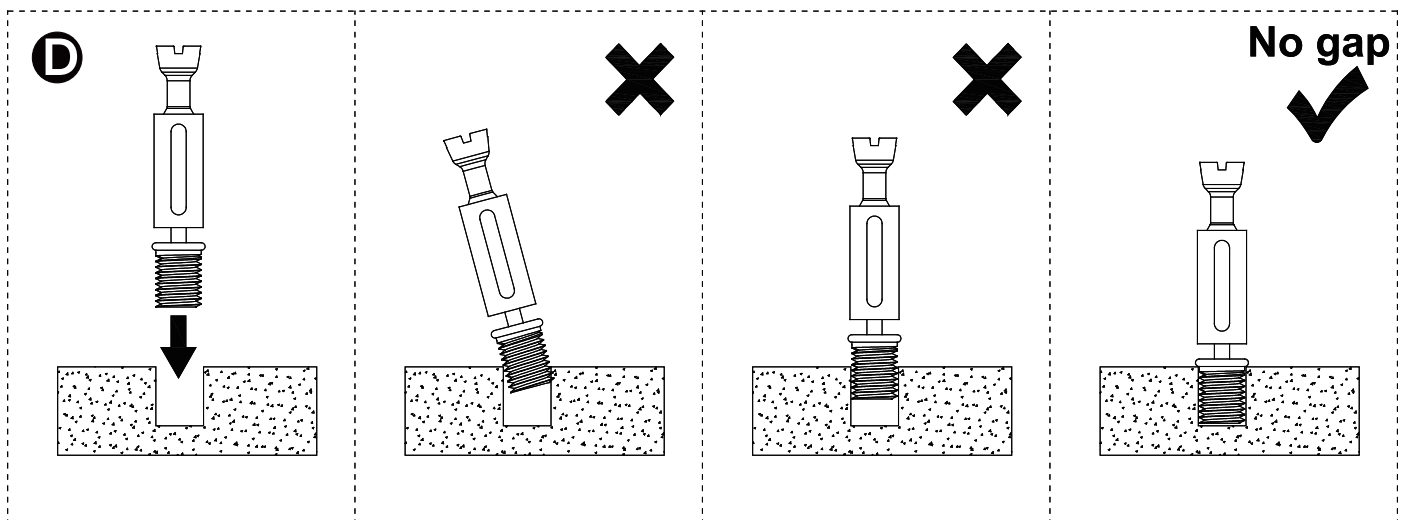
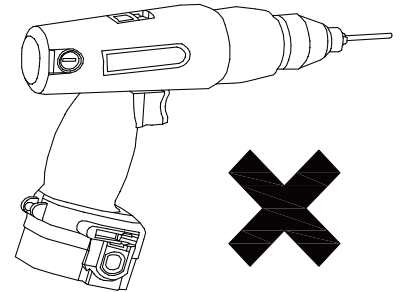

Screw the pin into the hole. Set the cams correctly by aligning the head of the cams with the lock pins. Lock the cam by turning the cam head with a screwdriver until it is tightened. Please do not use an electric screwdriver to assemble the unit.

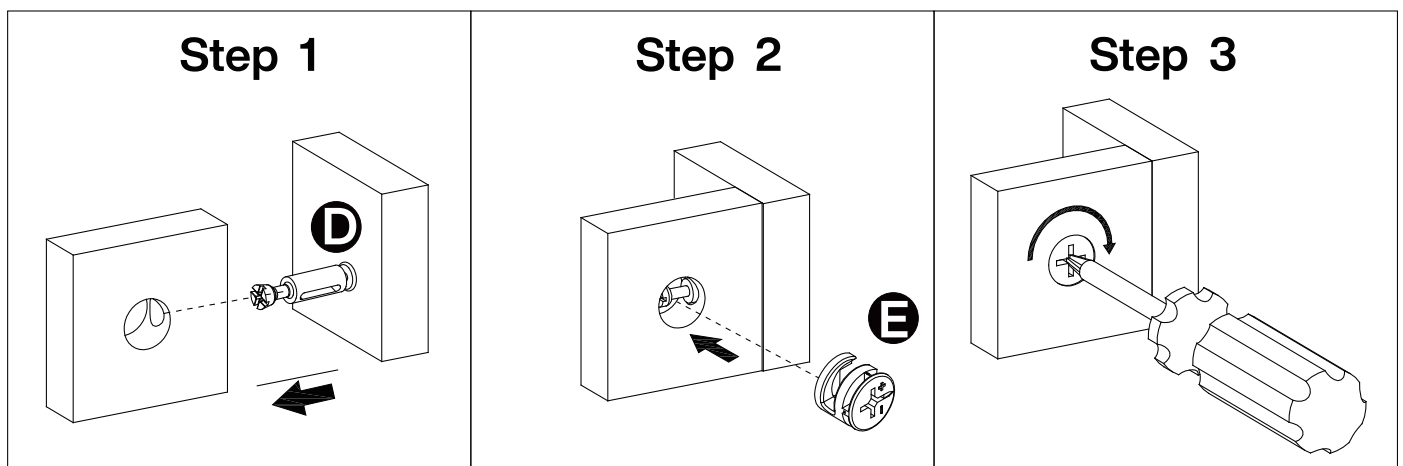

Please split component "32" into "32-A" and "32-B" before assembling the slide and then proceed to the next step of assembly

Step 1

Pull apart component "32" to each side, and then gently push up the lever of component "32-B"

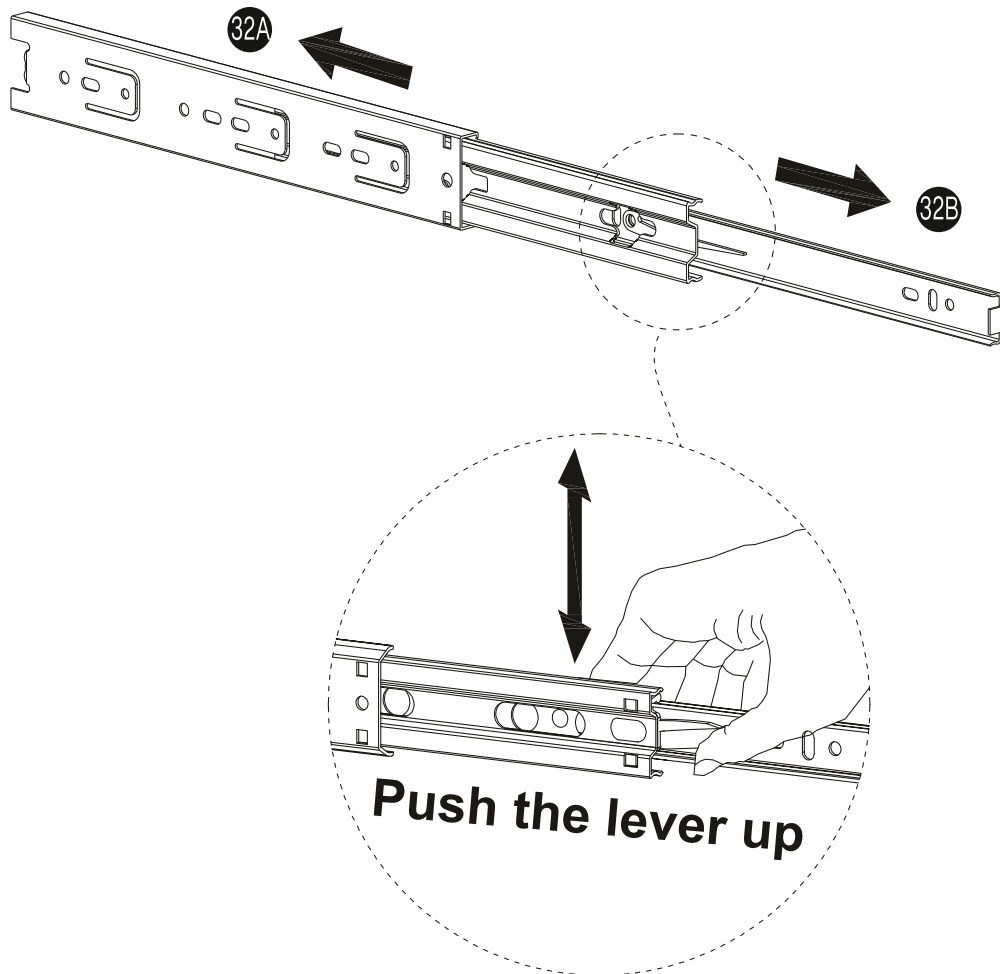

Step 2 Split component "32-A" and "32-B"

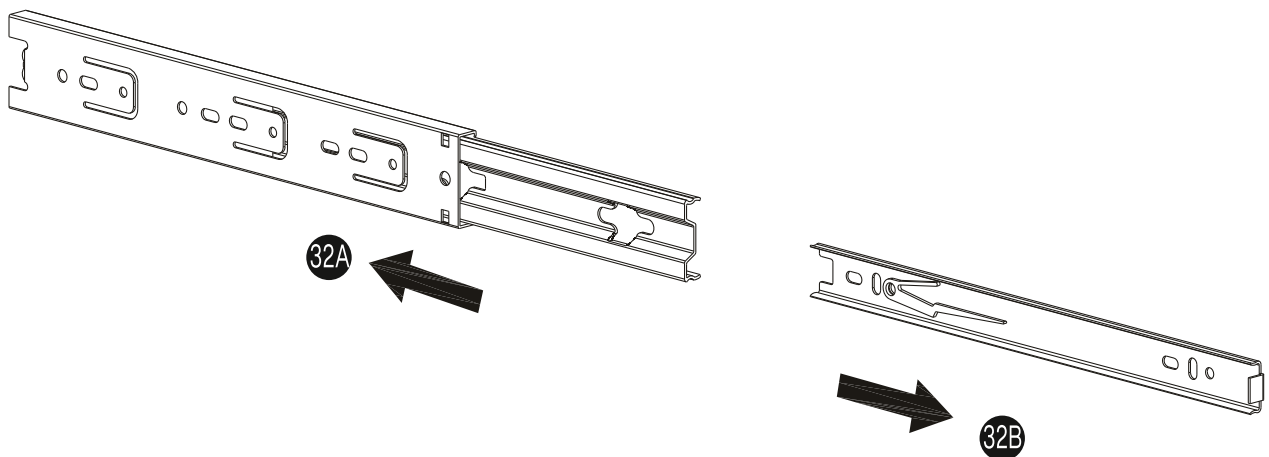

1

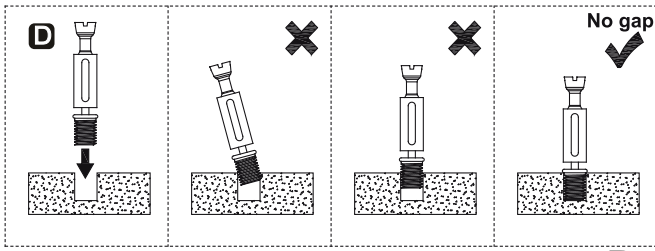

D

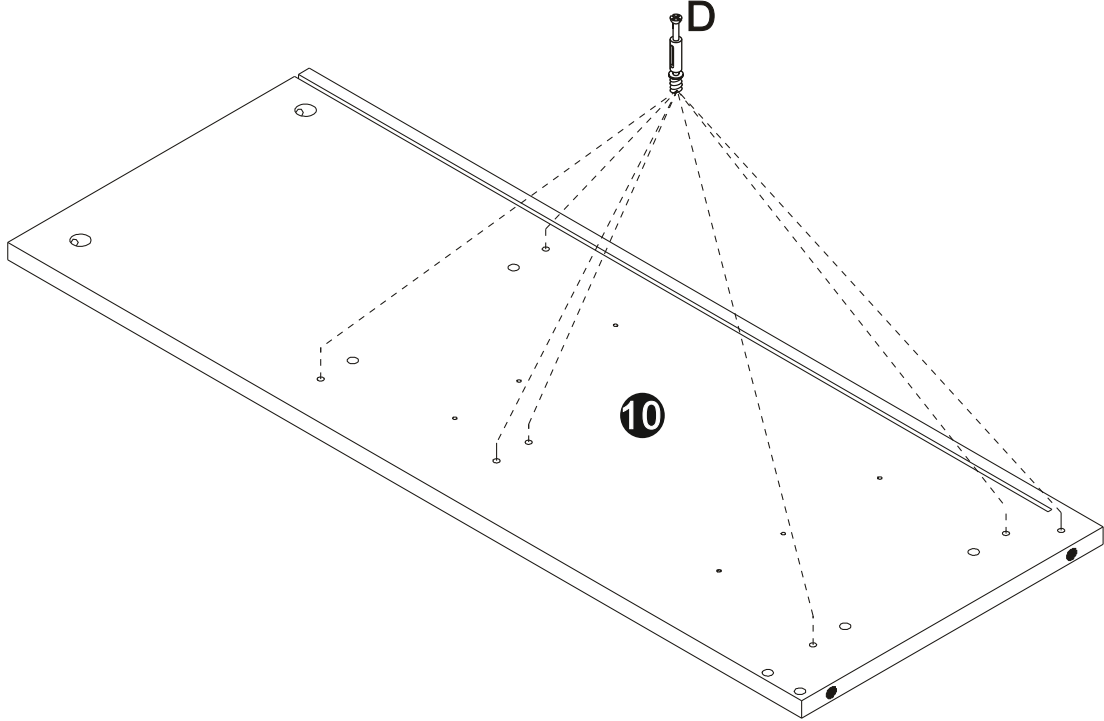
M6x44.5mm
7 pcs

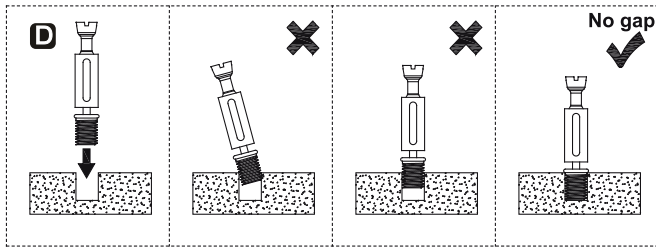

2

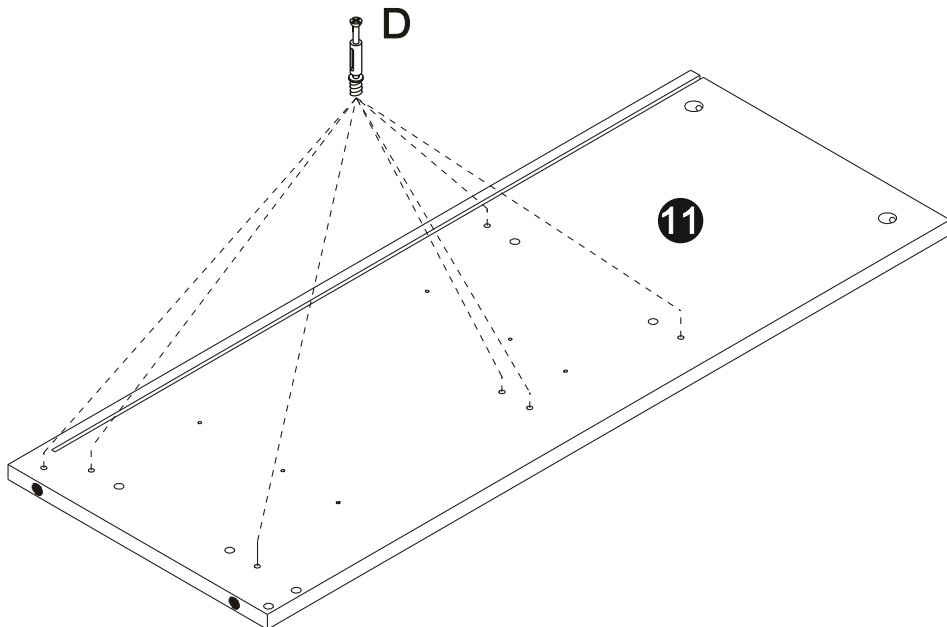

D

M6x44.5mm
7 pcs



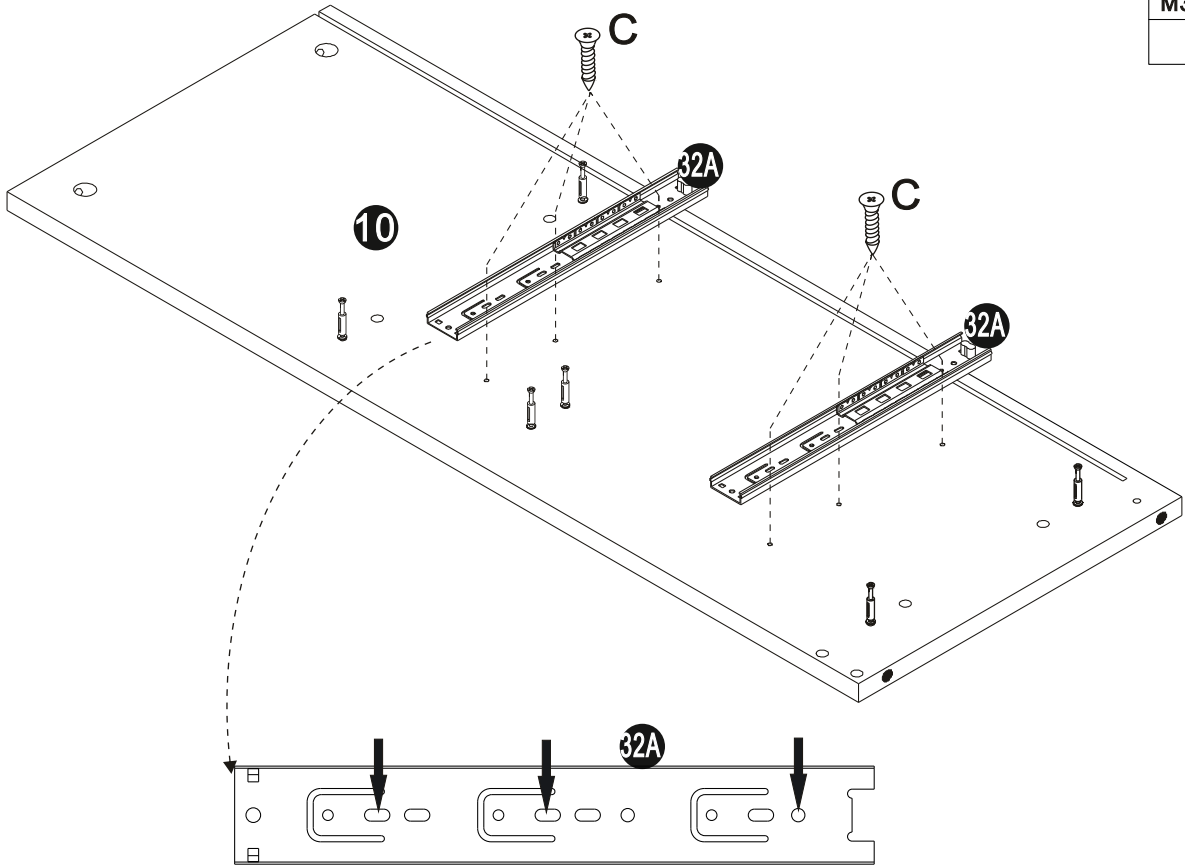

3

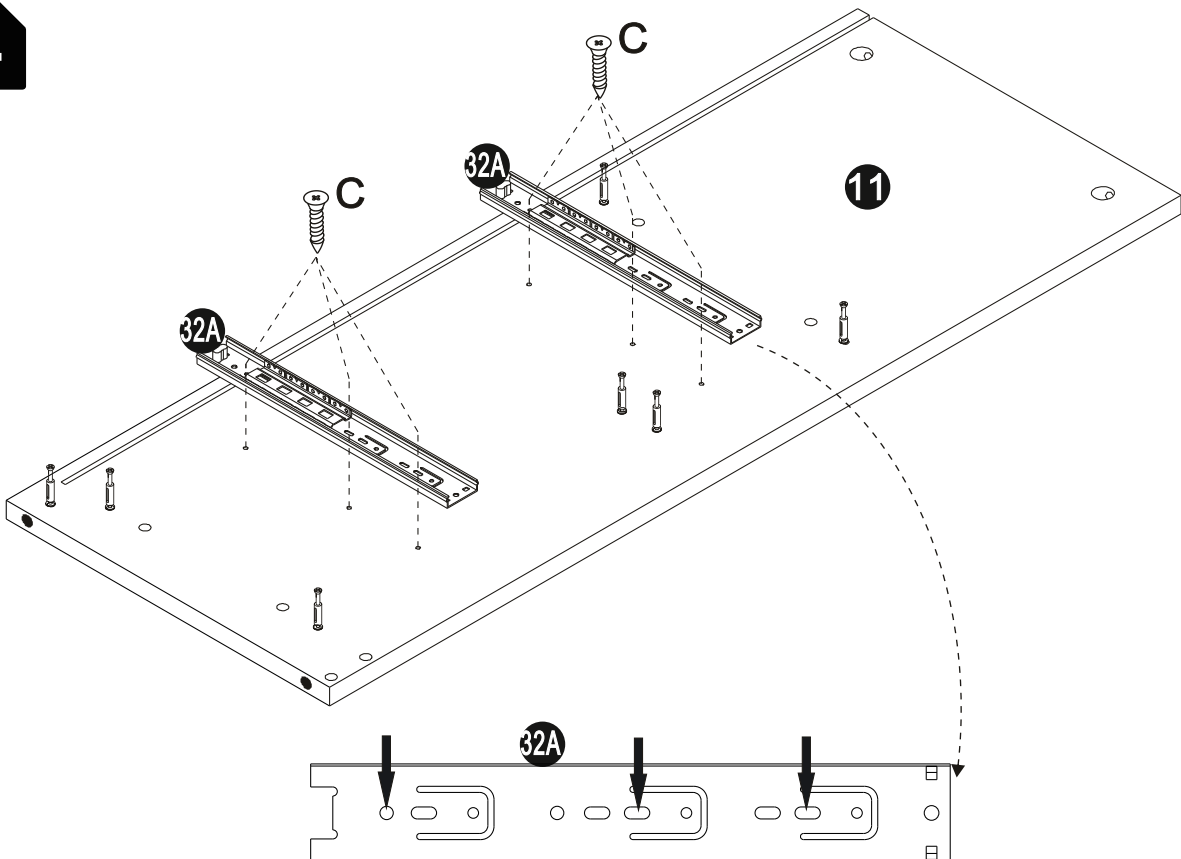

C

M3.5x14mm
6 pcs

4

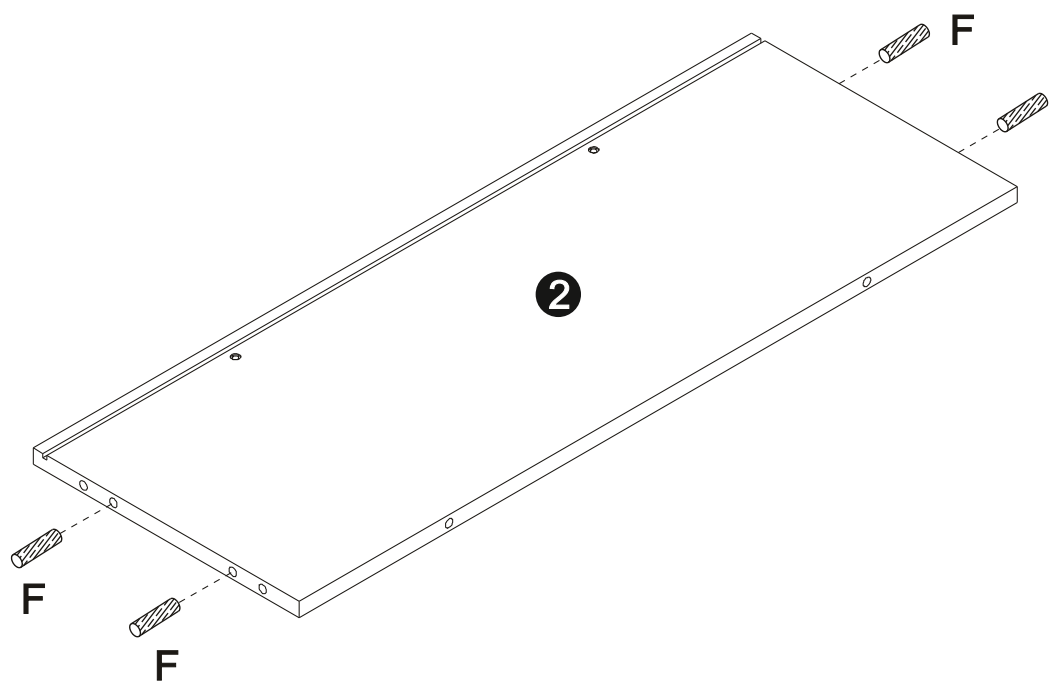

C

M3.5x14mm
6 pcs

5

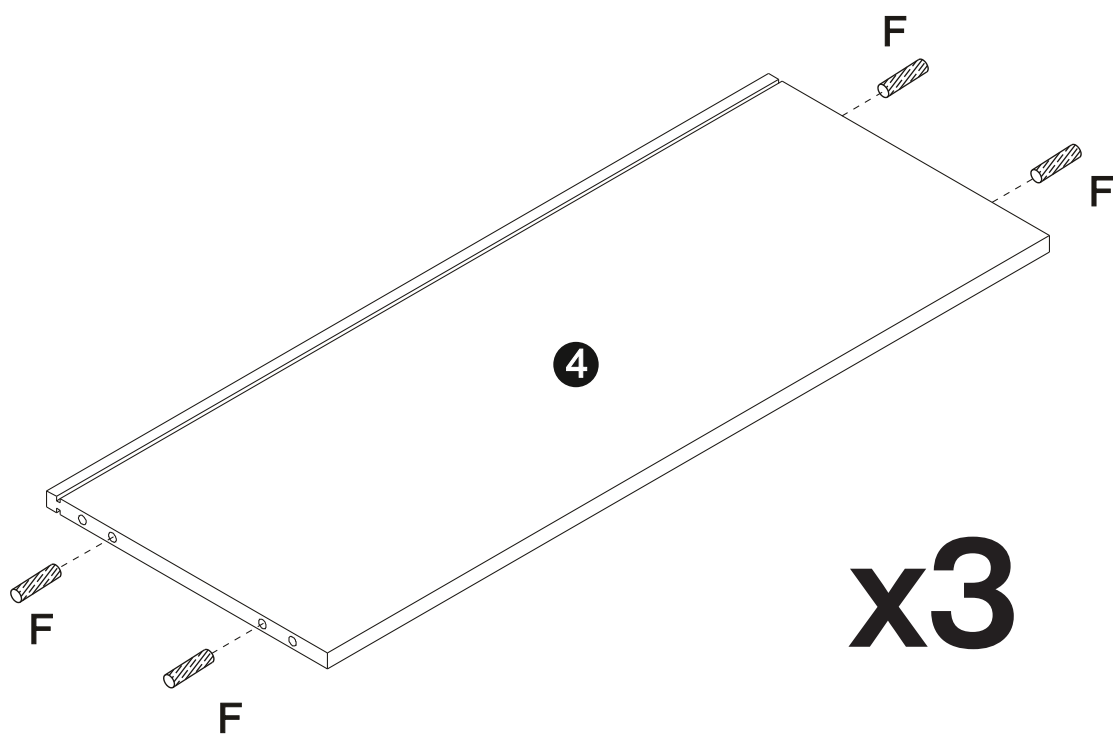

F

Ø6X30mm
4 pcs

6

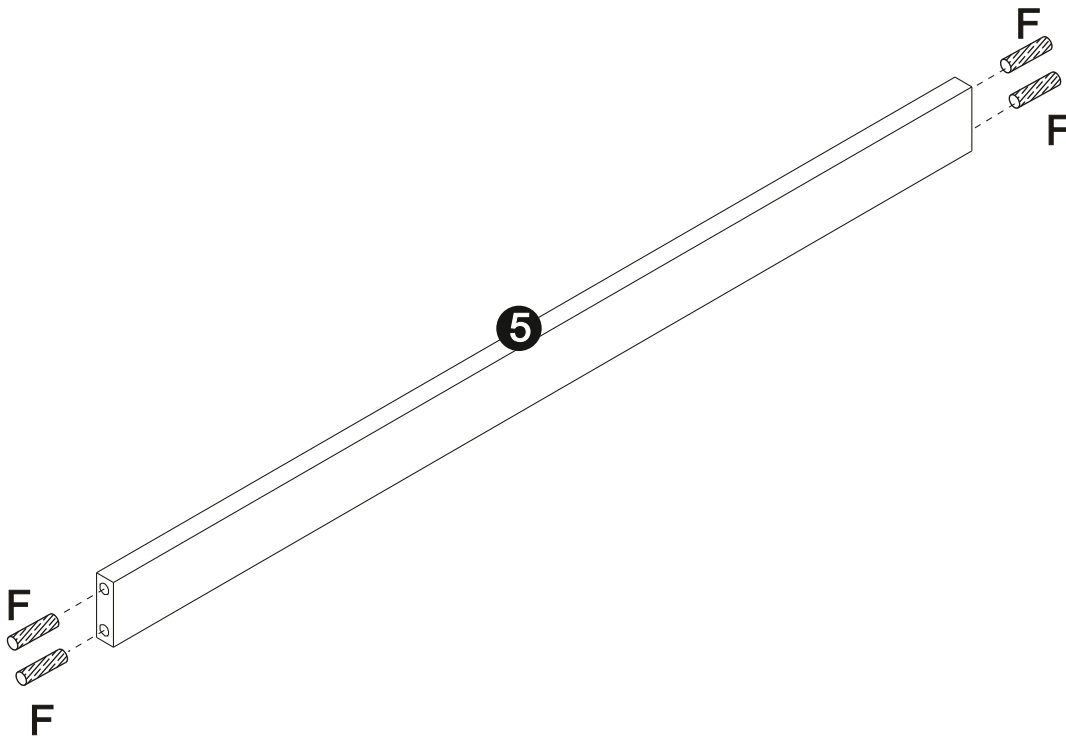

F

Ø6X30mm
12 pcs

7

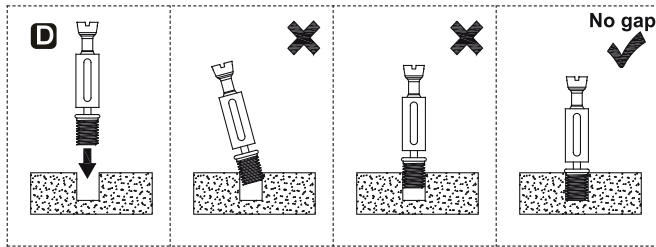

F

Ø6X30mm
4 pcs

8

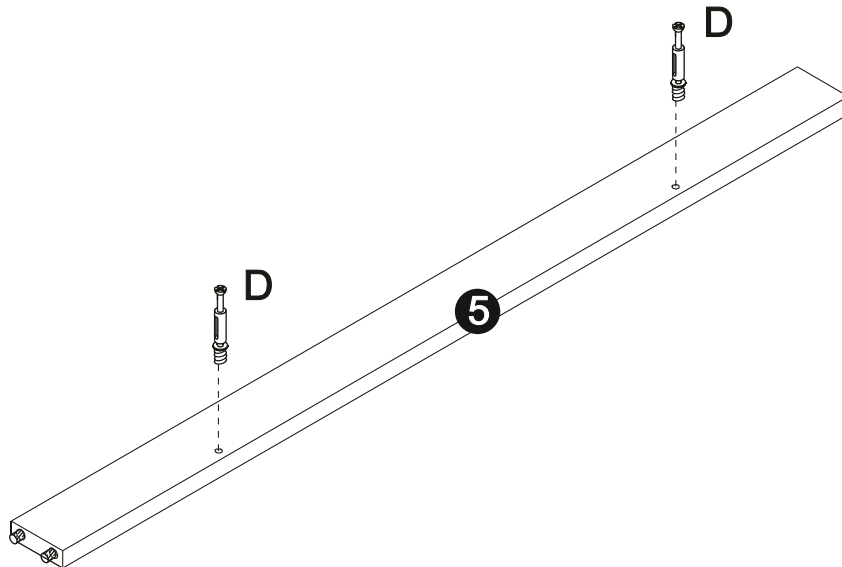

D

M6x44.5mm
2 pcs

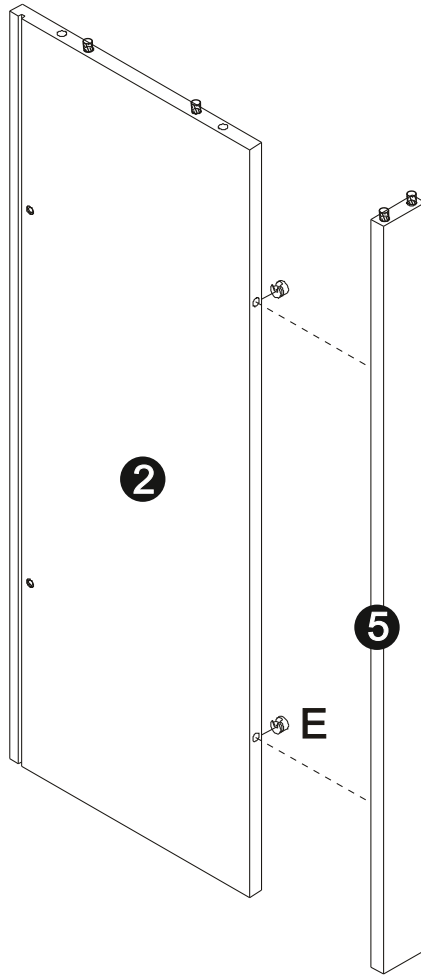

9

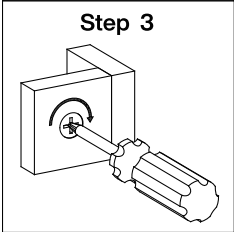
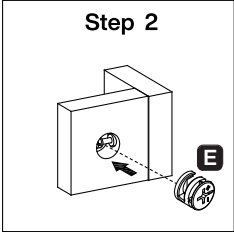
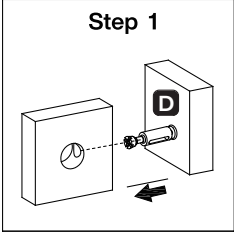

E
Ø15mm
2 pcs



10

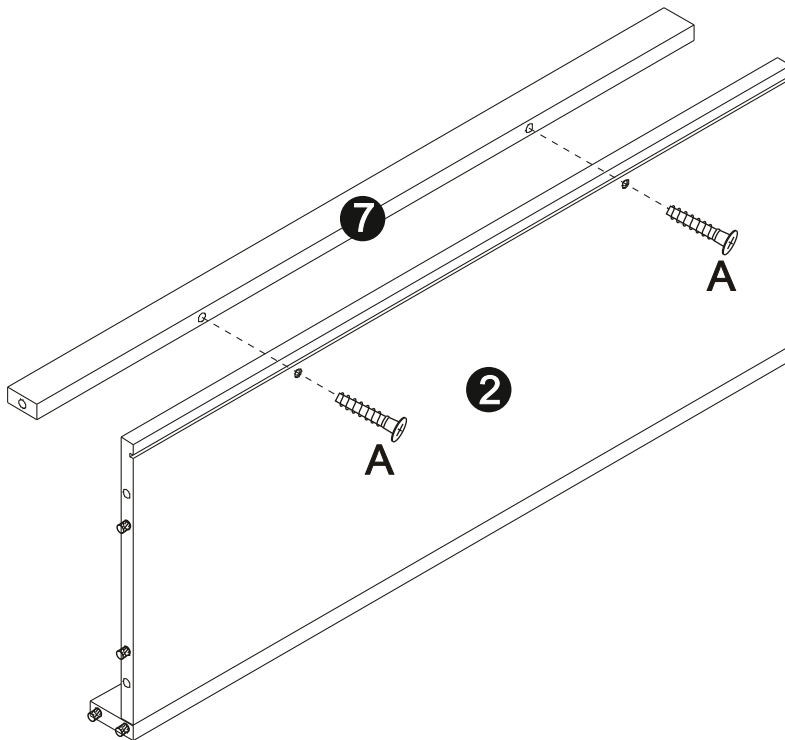

A
M5x38mm
2 pcs

11

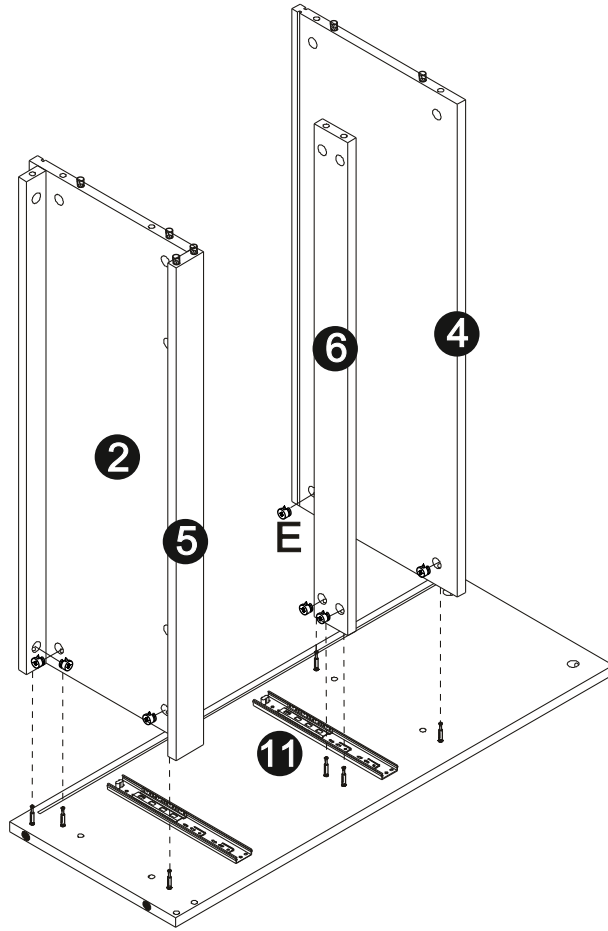

E
Ø15mm
7 pcs

Step 1

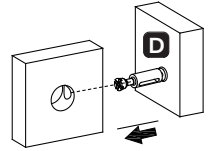

Step 2

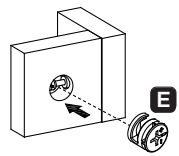

Step 3

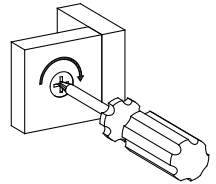

12

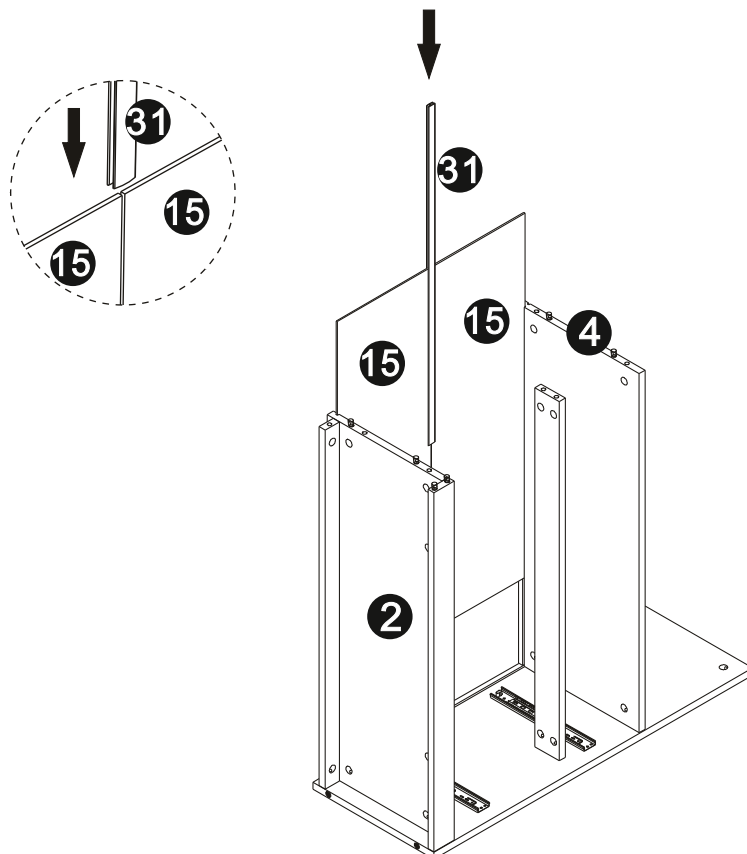

13

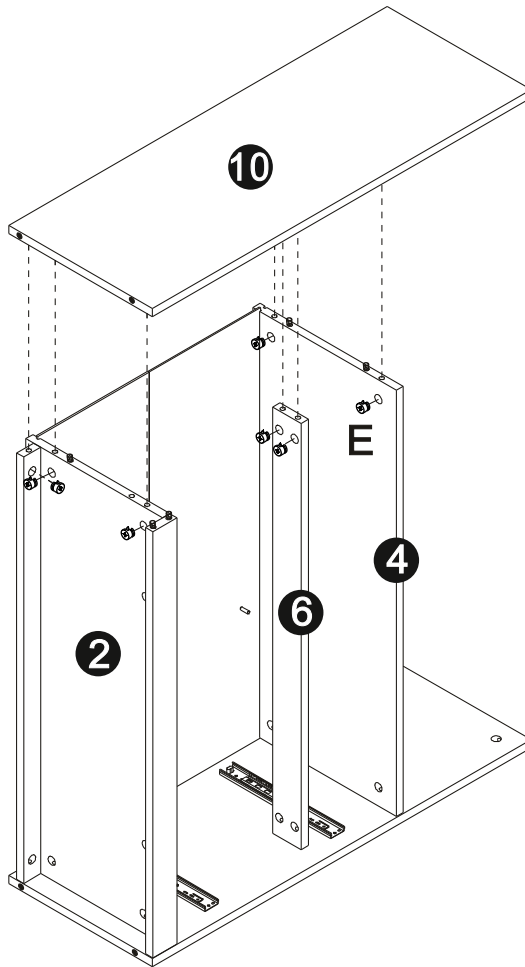

E
Ø15mm
7 pcs

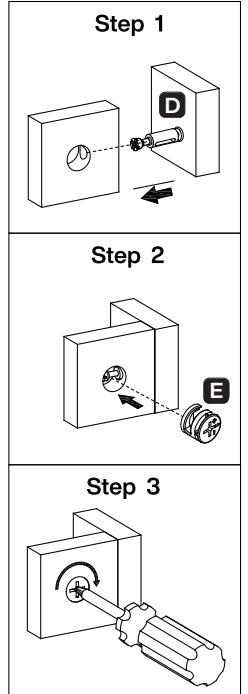

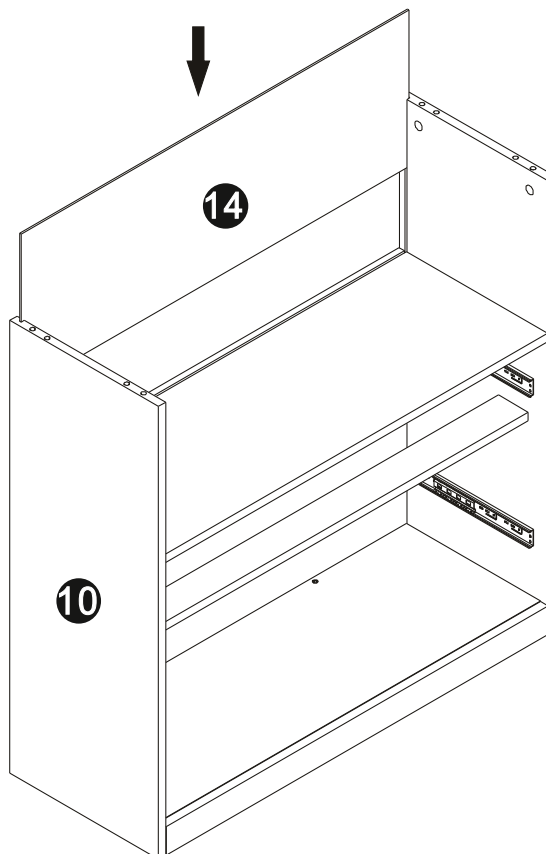

14

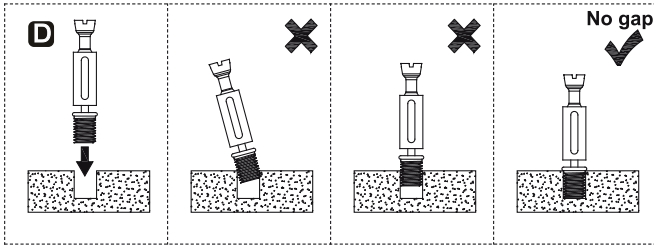

15



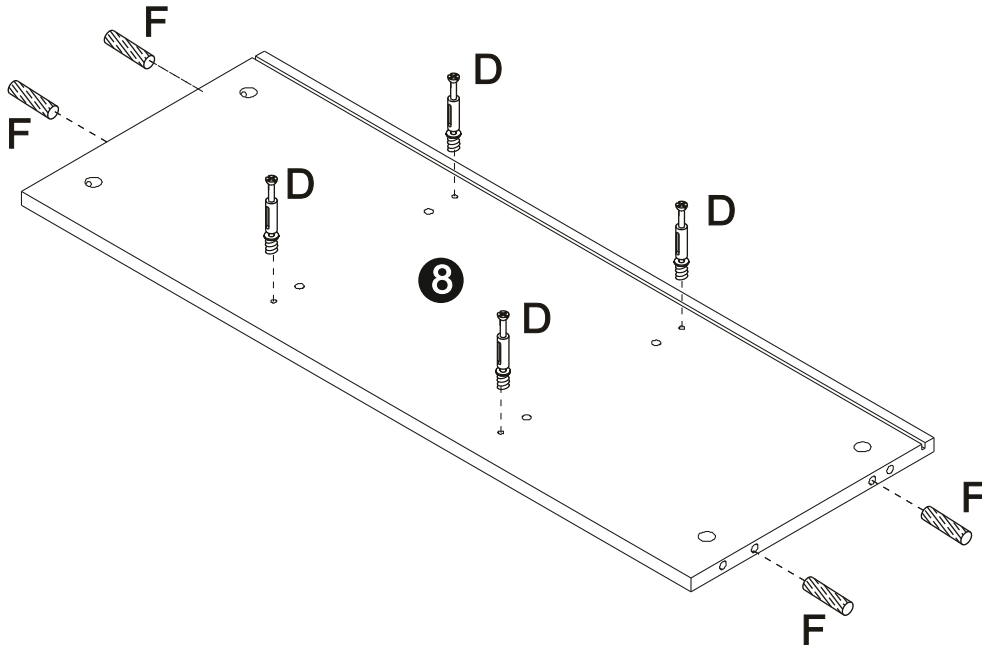

F	D
	
Ø6X30mm	M6x44.5mm
4 pcs	4 pcs

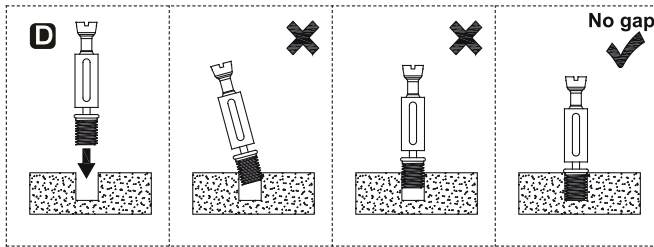

16



F	D
	
Ø6X30mm	M6x44.5mm
4 pcs	4 pcs

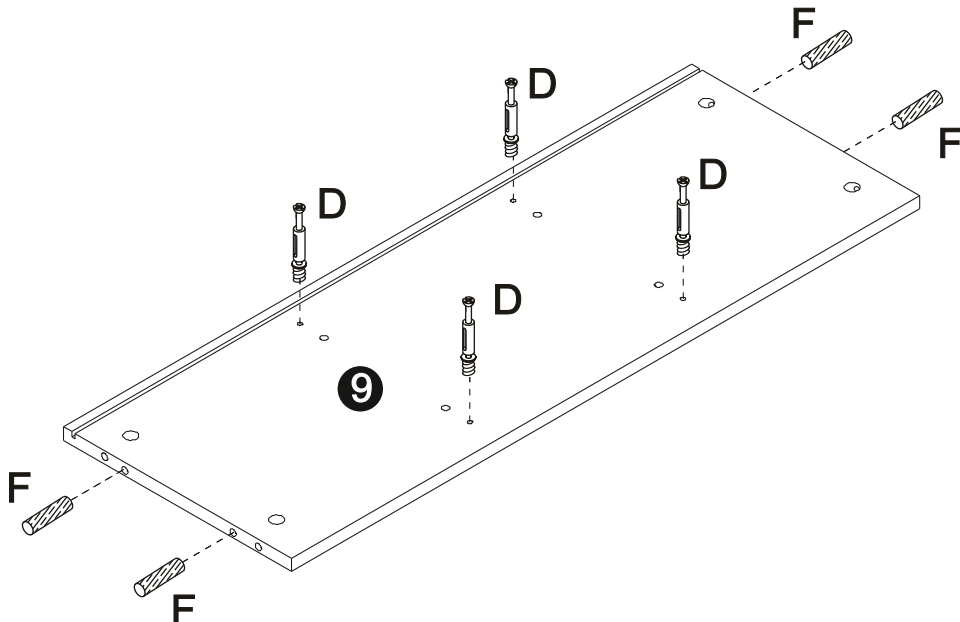

17

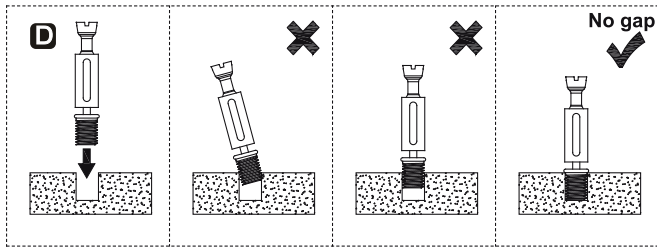

D

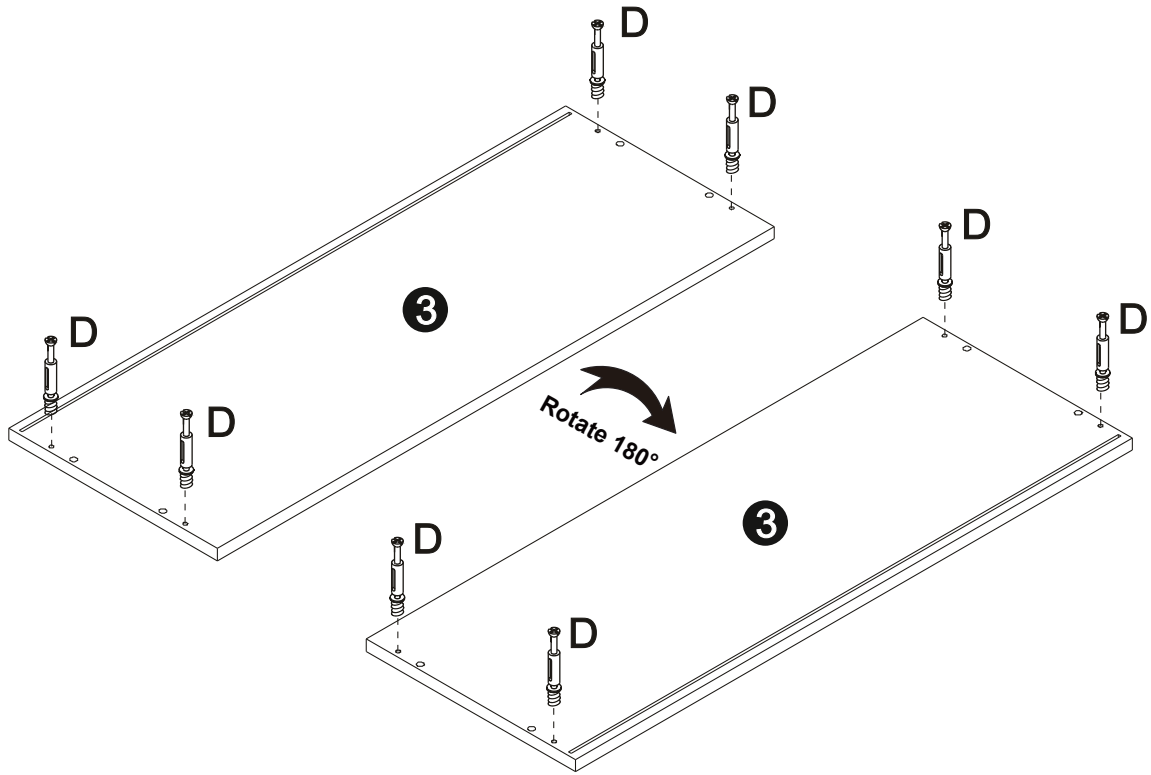
M6x44.5mm
8 pcs

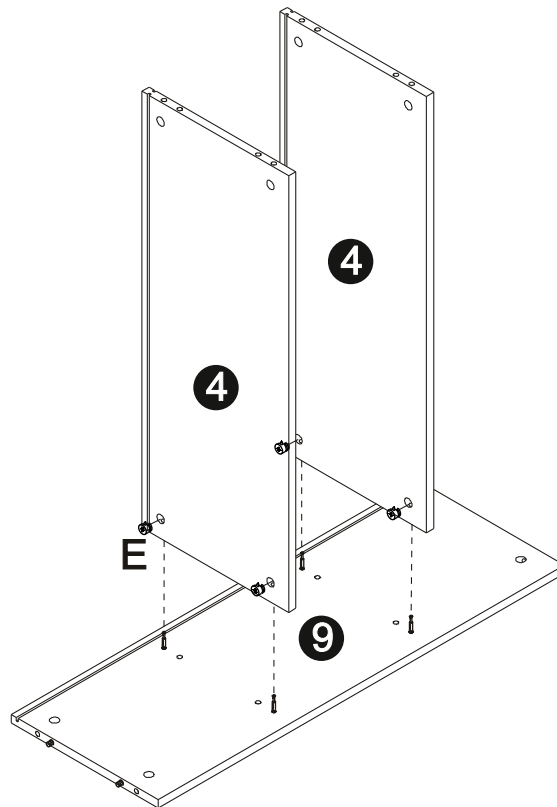
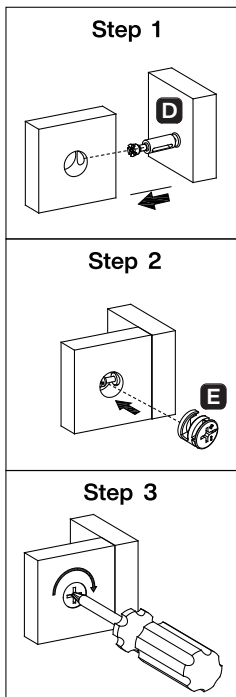

18



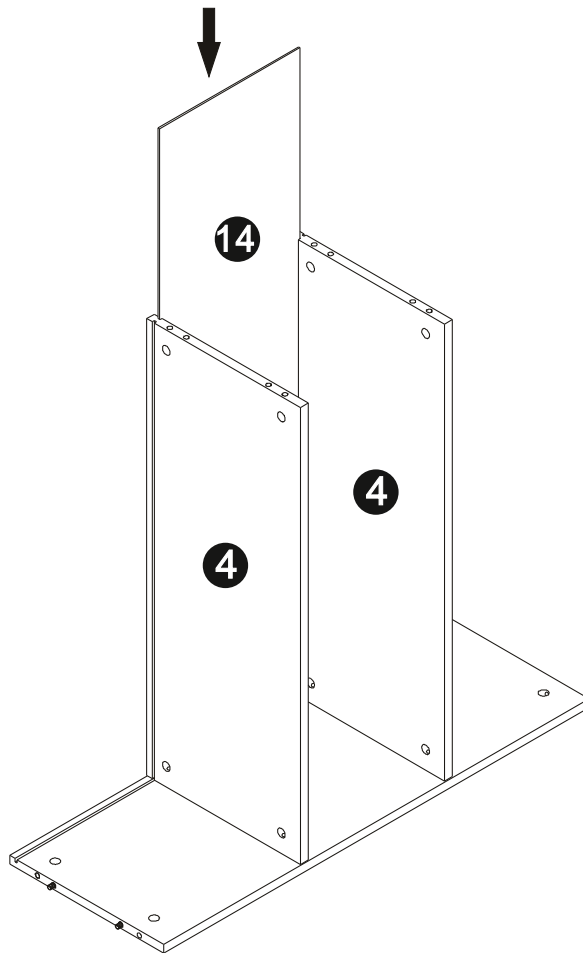

E

Ø15mm
4 pcs

19

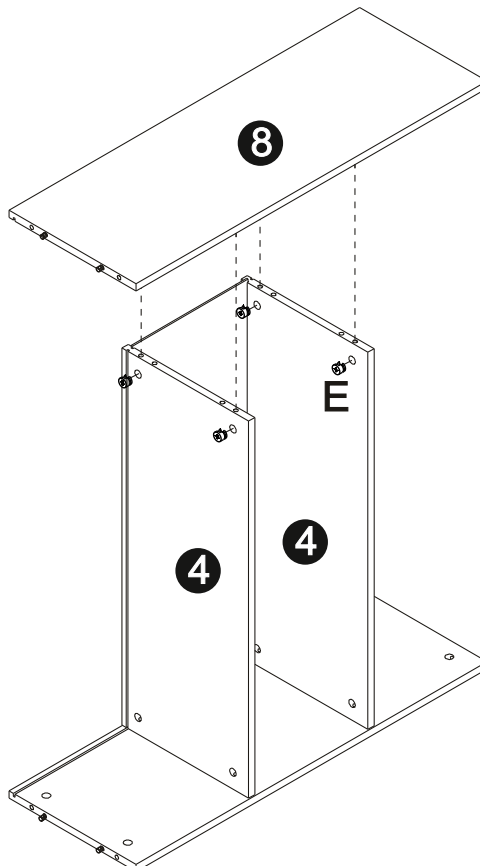
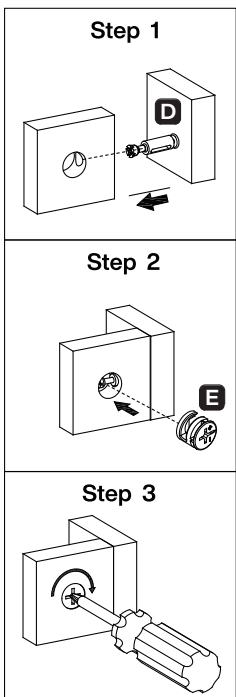

20



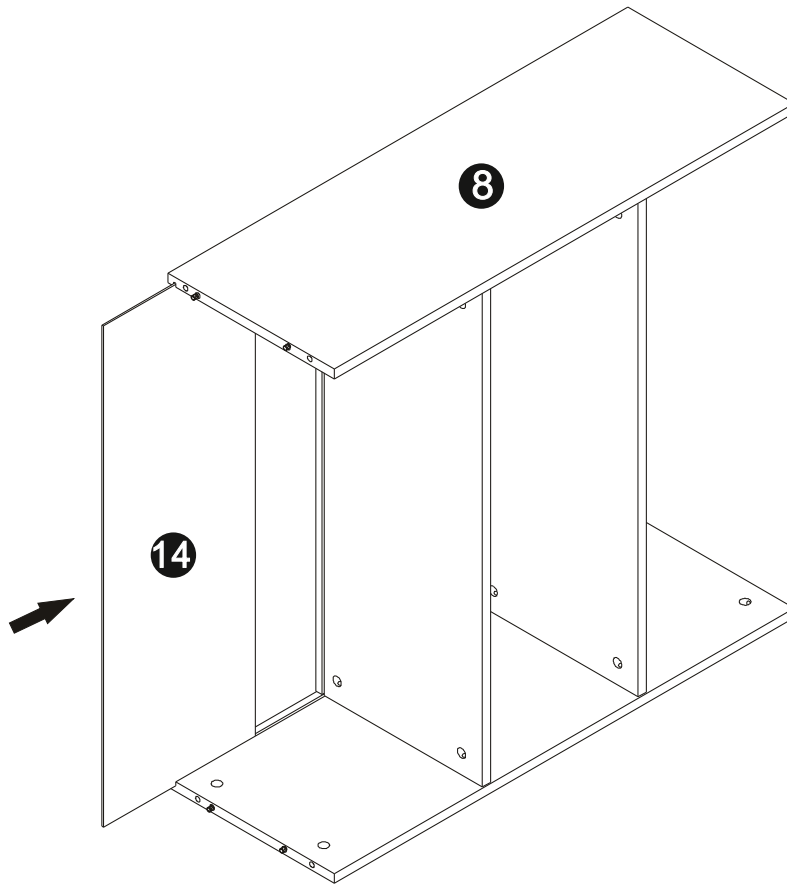

E

Ø15mm
4 pcs

21

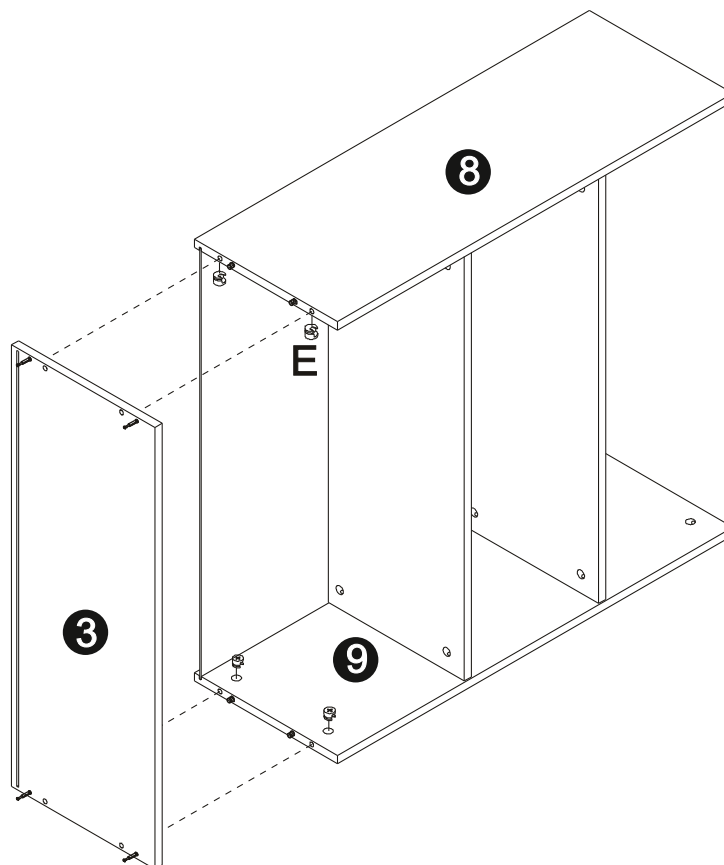
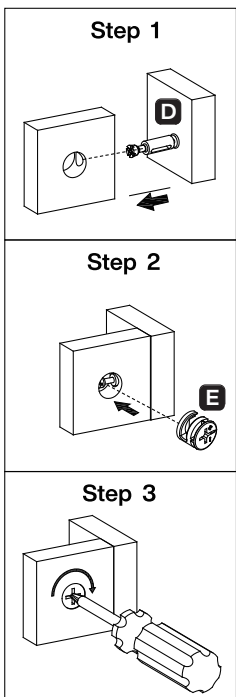



22

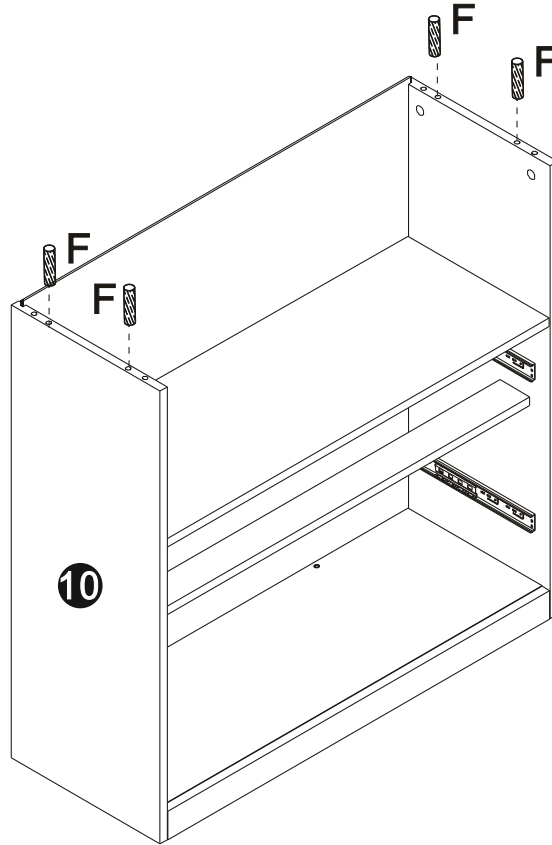

E

Ø15mm
4 pcs

23

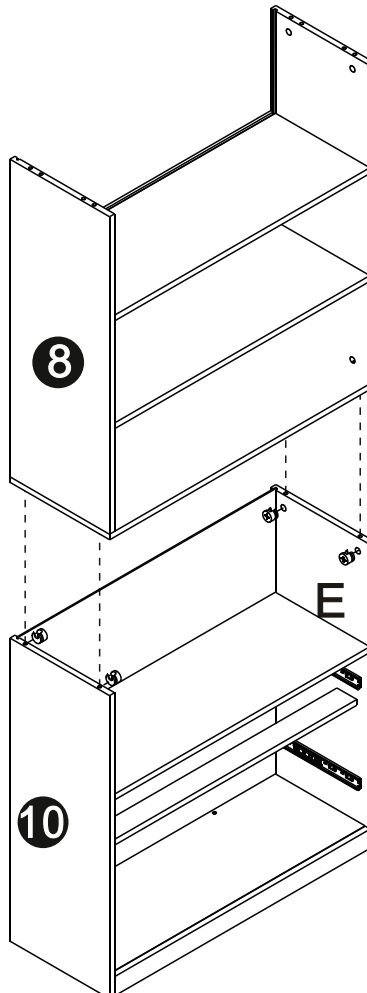
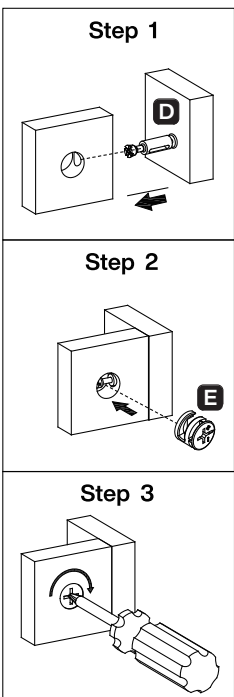

F

Ø6X30mm
4 pcs

24



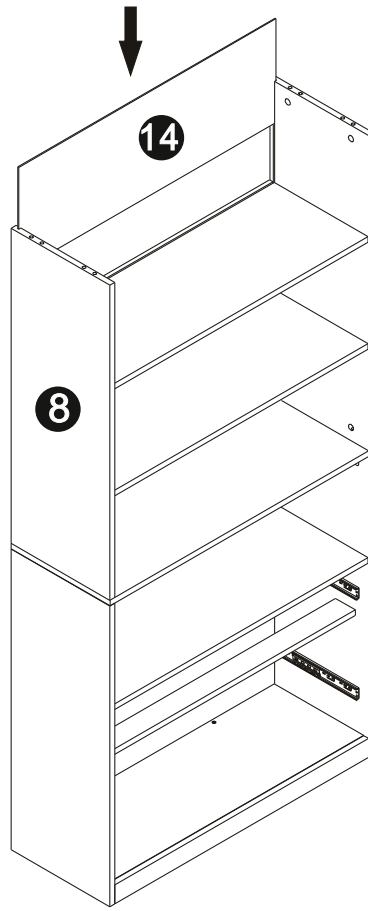

E

Ø15mm
4 pcs

25

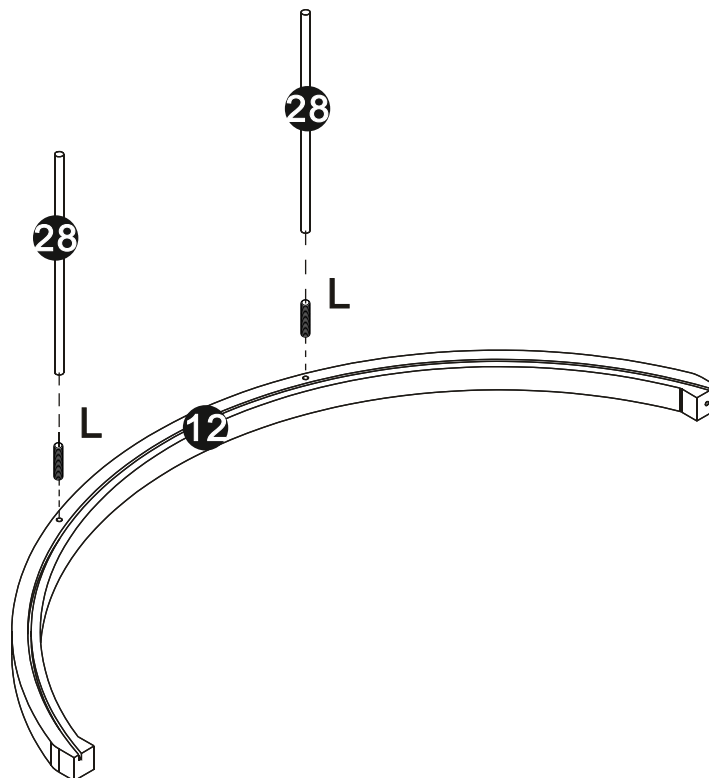

26



L

M4x20mm
2 pcs

27

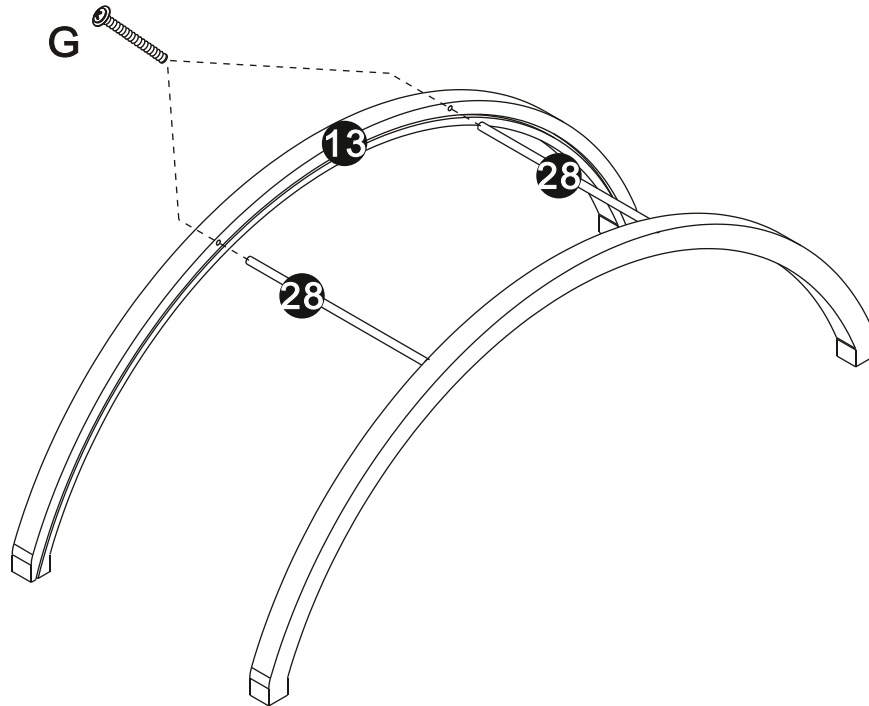
G

M4x35mm
2 pcs

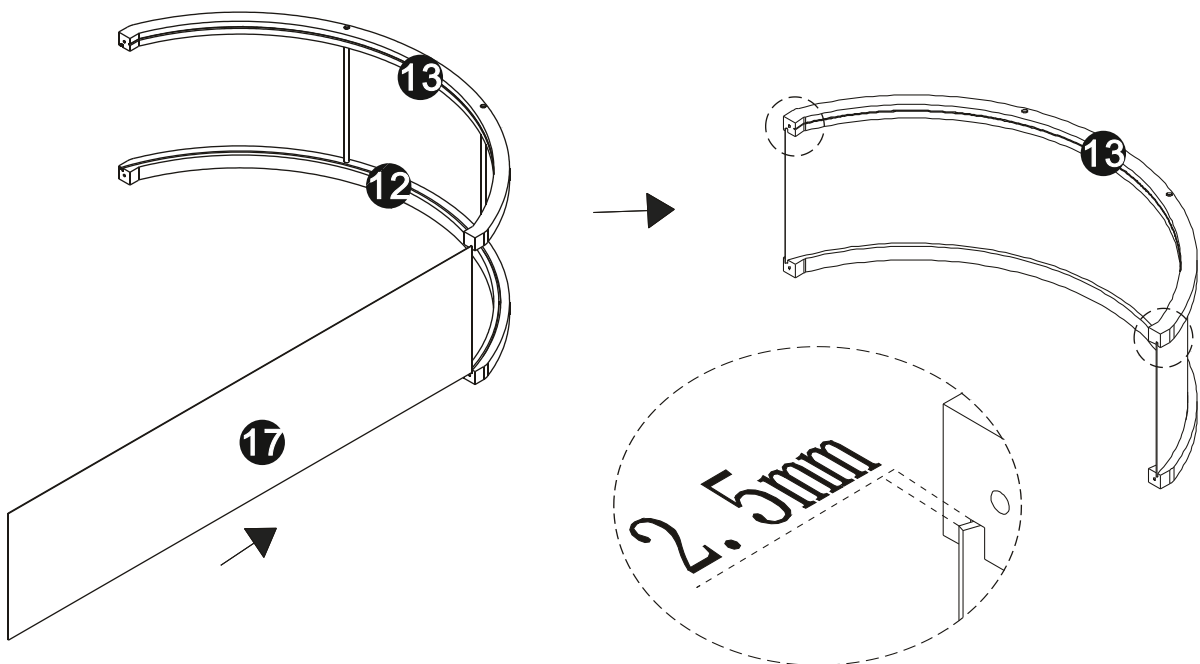

28



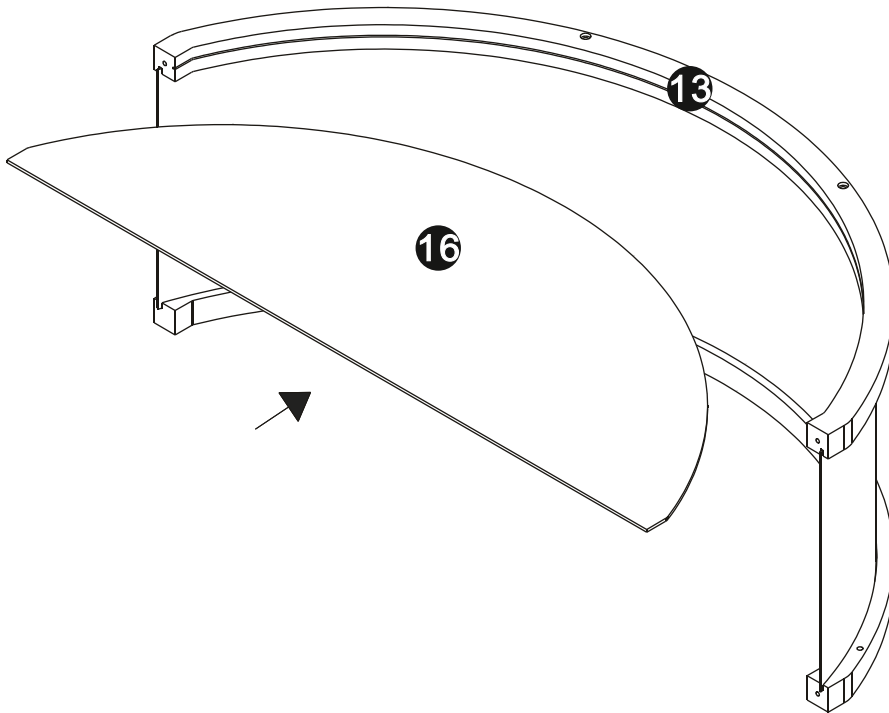

Gently bend #17 and install it along the guide slots of #12 and #13. Ensure 2.5 mm end gaps after installation.

29



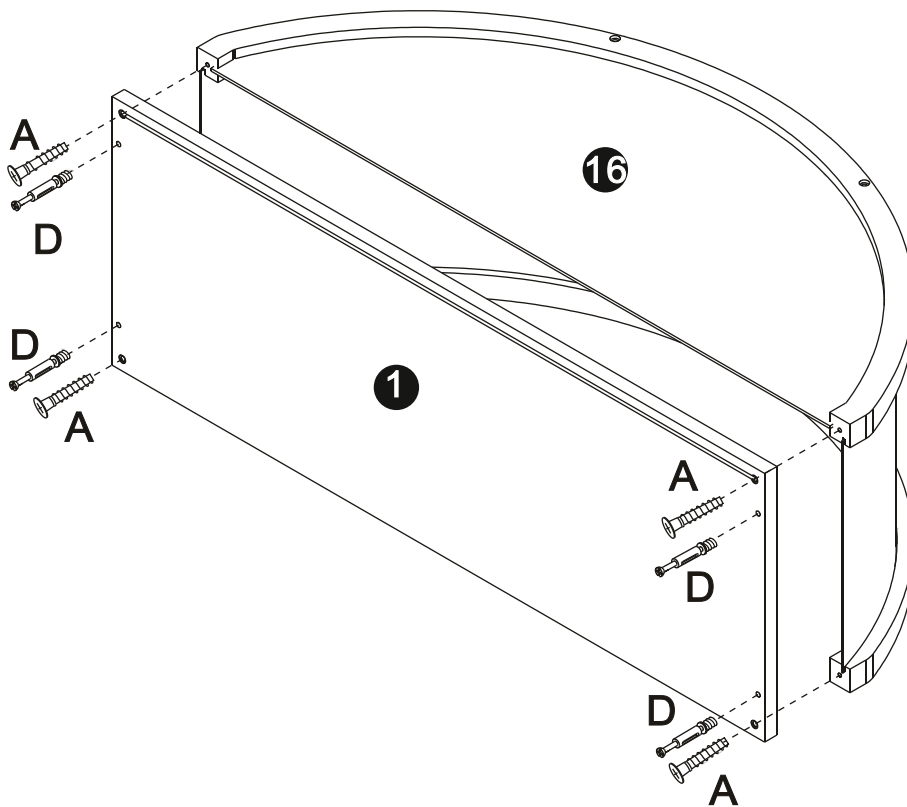

30

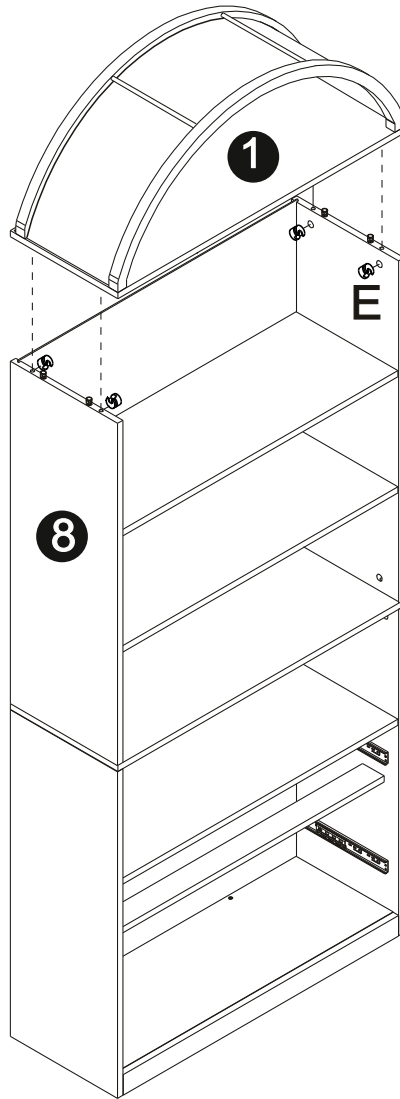
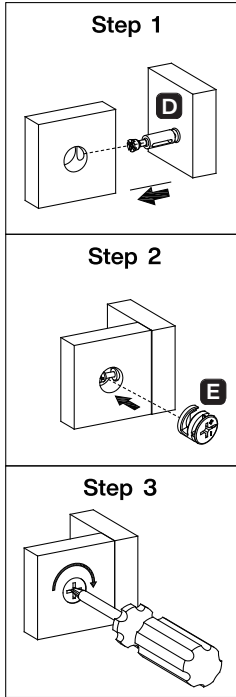

A

M5x38mm
4 pcs
D

M6x44.5mm
4 pcs

31

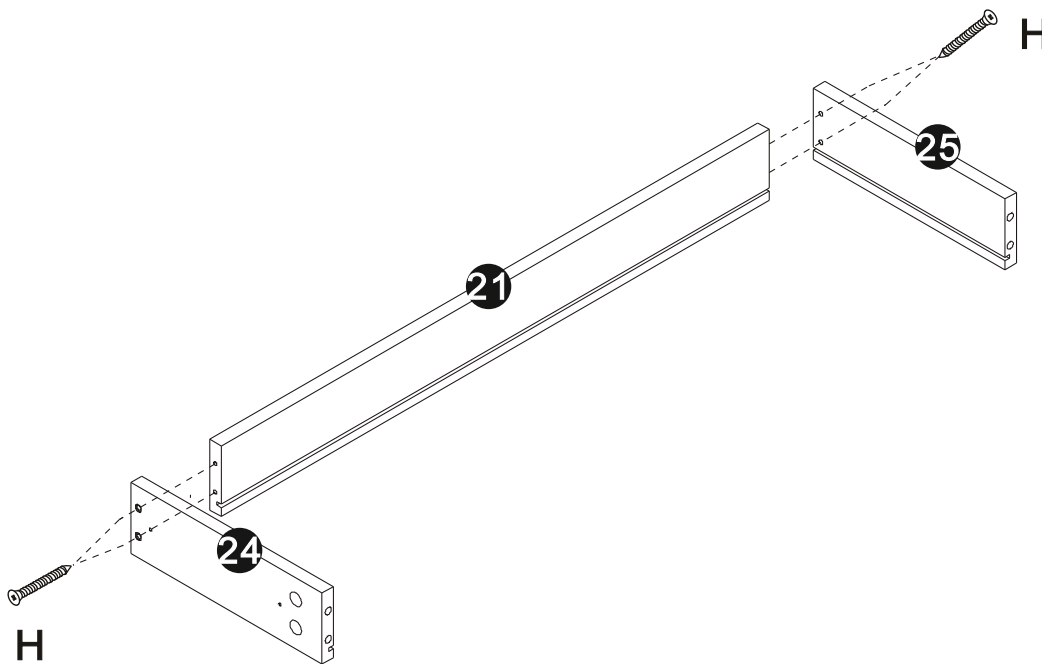

E

Ø15mm
4 pcs

32



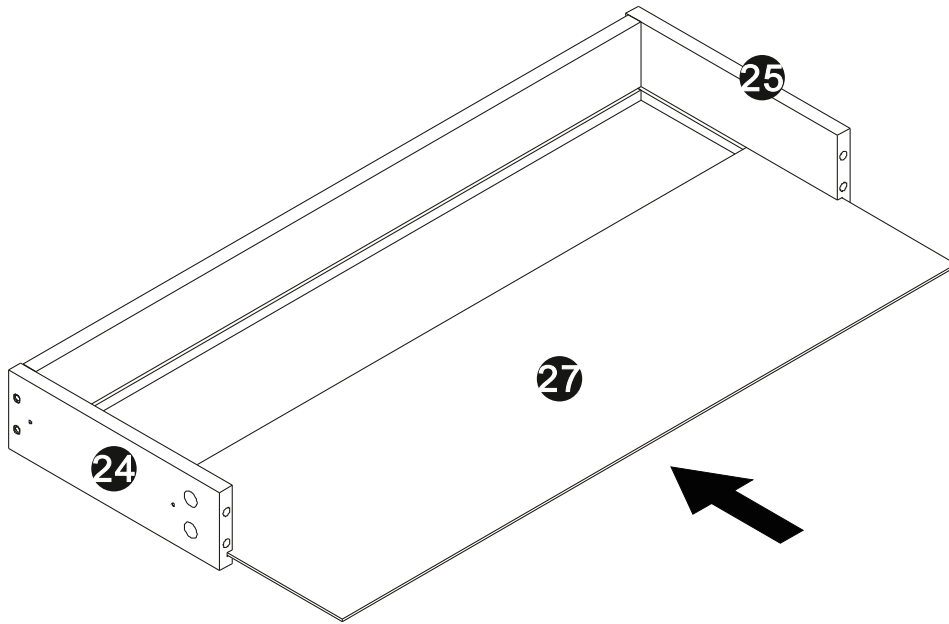

H

M4x35mm
4 pcs

33

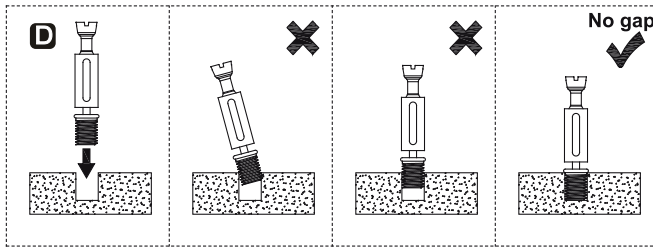

34

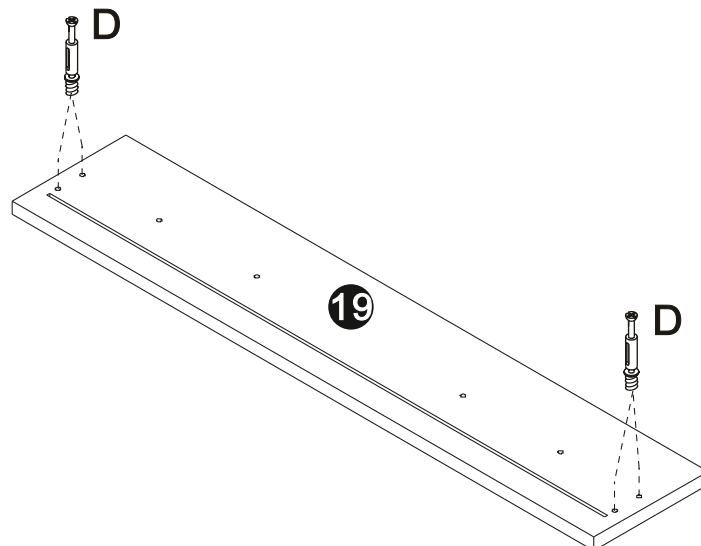

D

M6x44.5mm
4 pcs

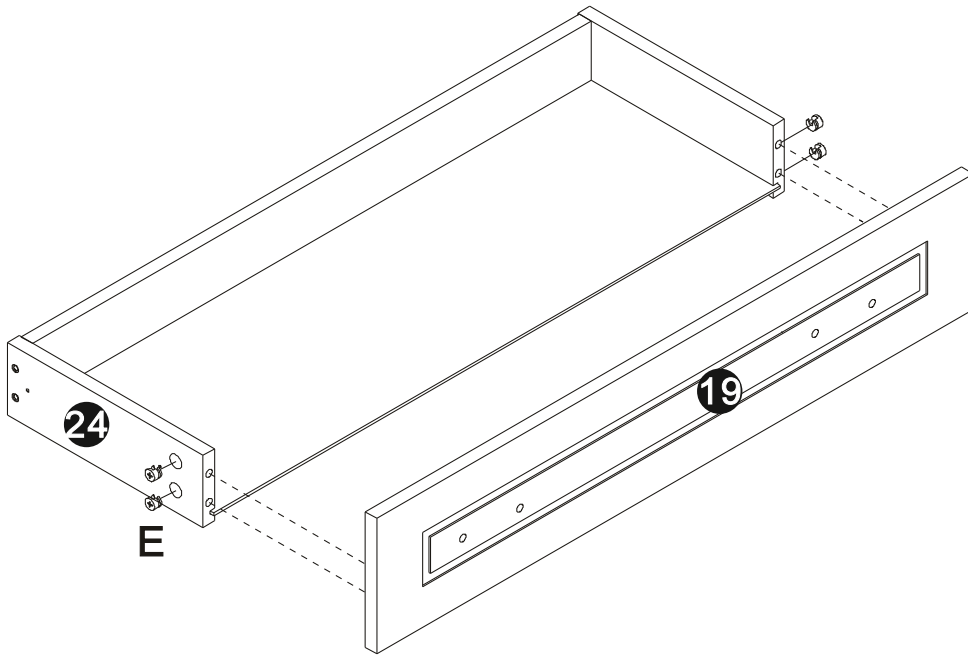

35

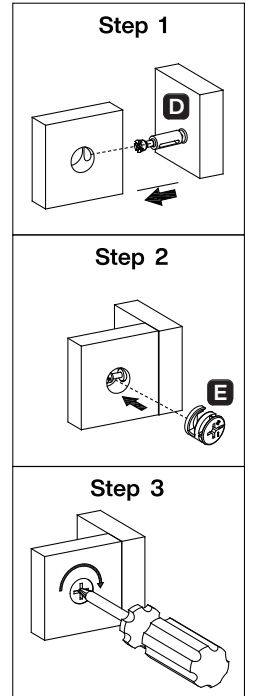

E

Ø15mm
4 pcs



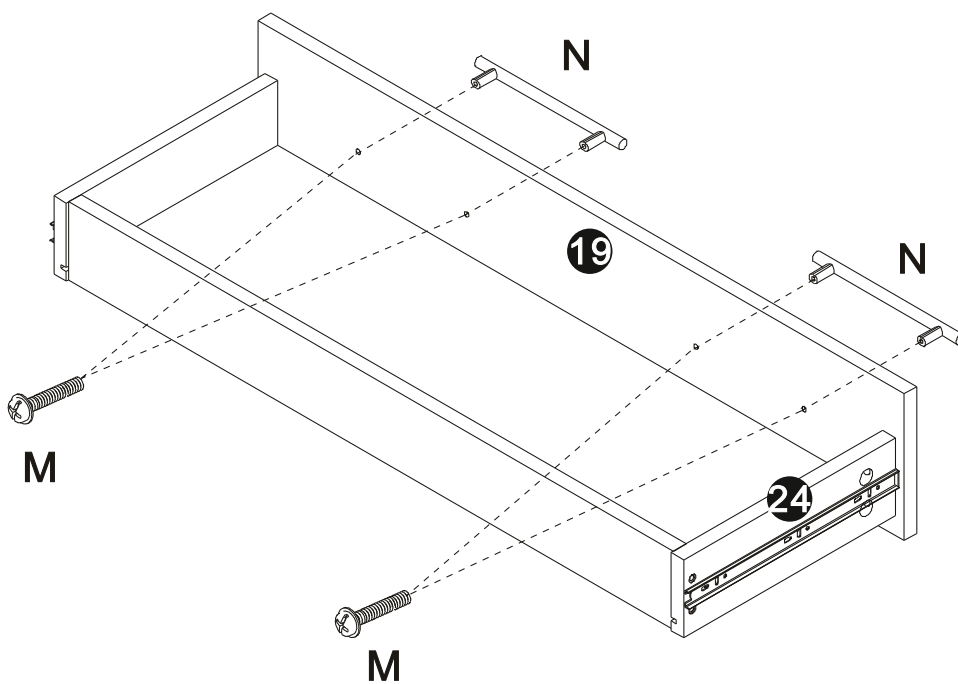

36

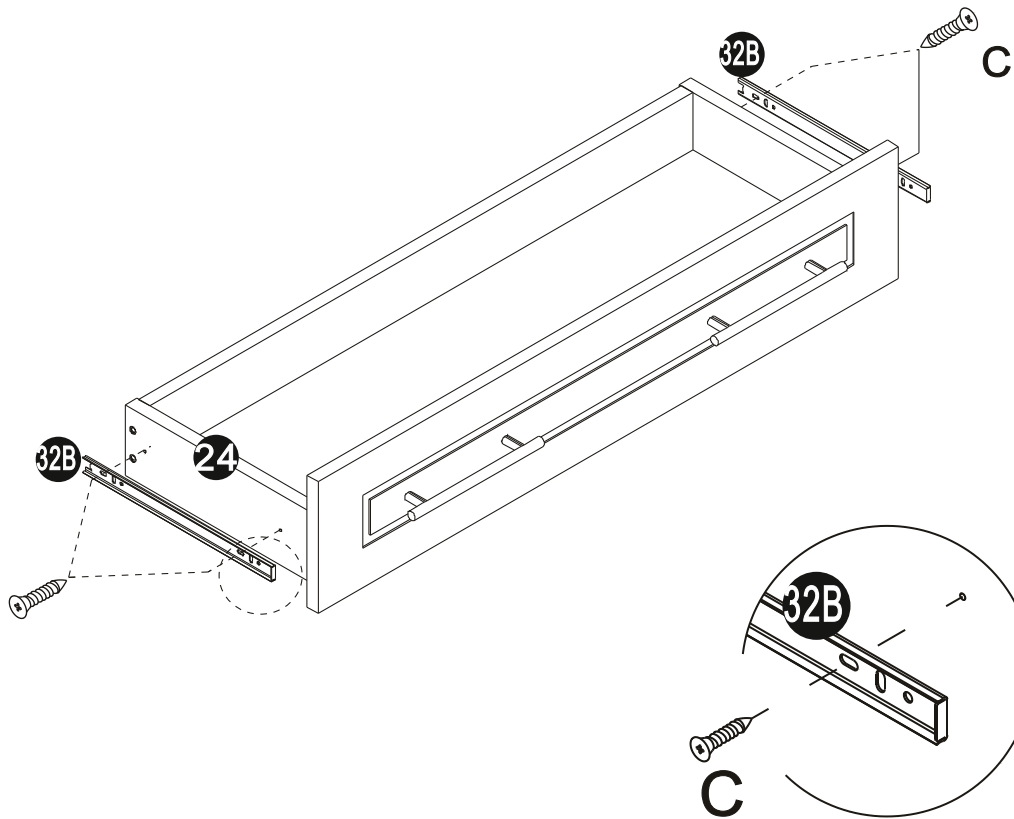

M

4X8mm
4 pcs

37

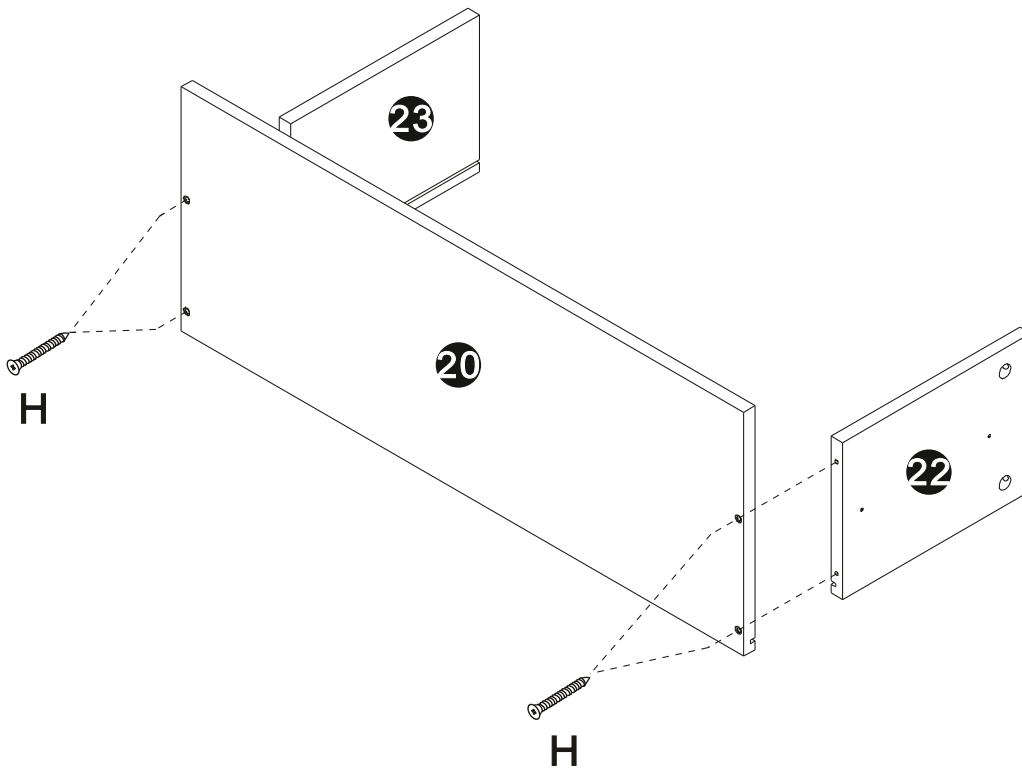

C

M3.5x14mm
4 pcs

38



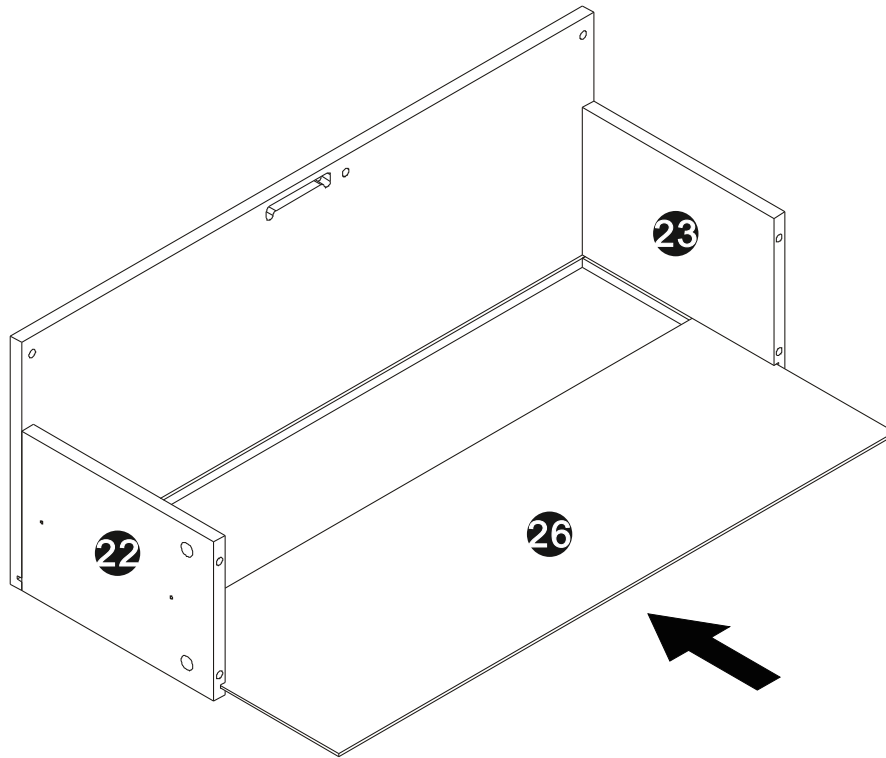

H

M4x35mm
4 pcs

39

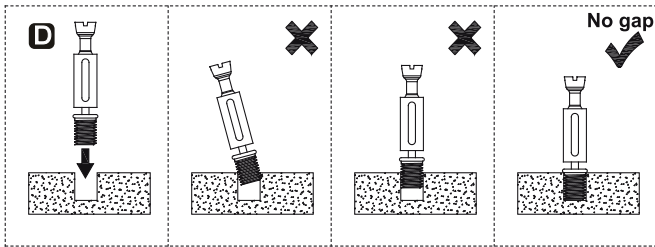

40

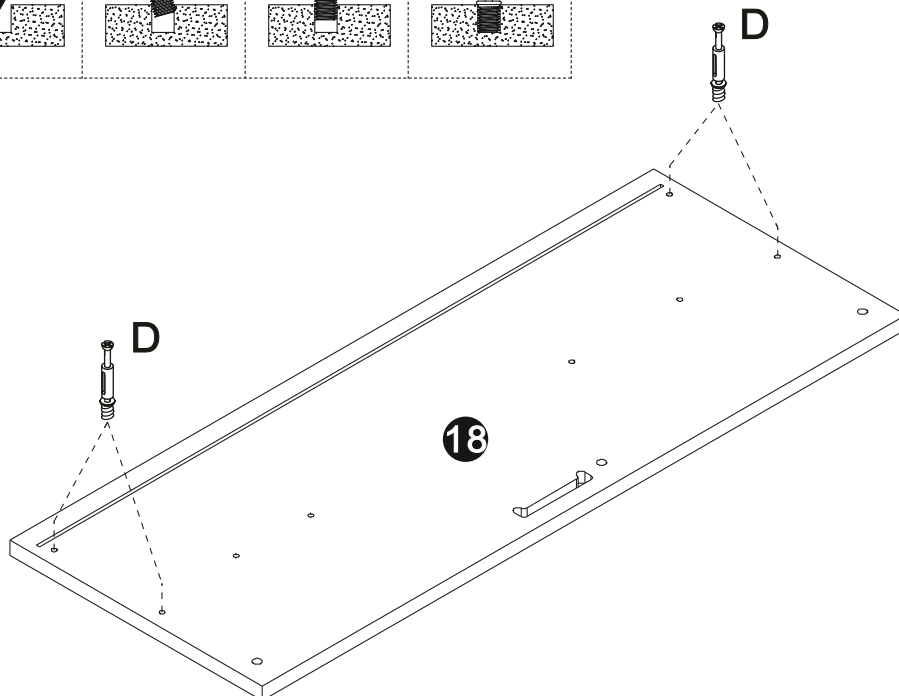

D

M6x44.5mm
4 pcs

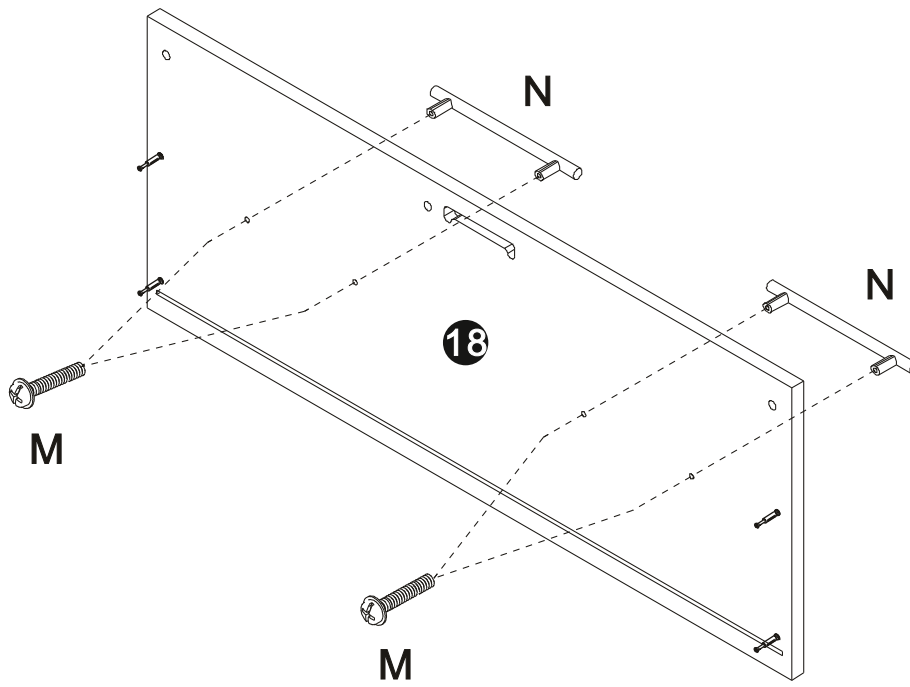

41



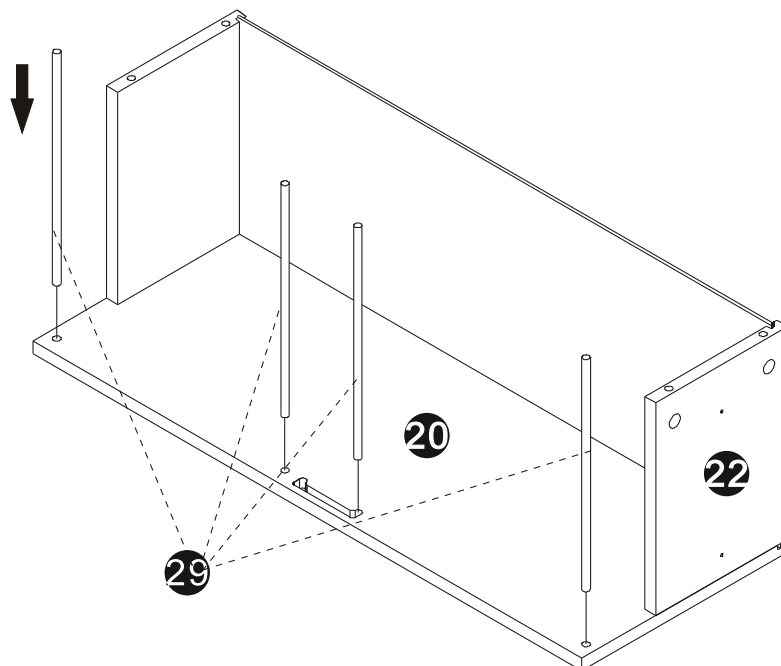

M

4 pcs

42

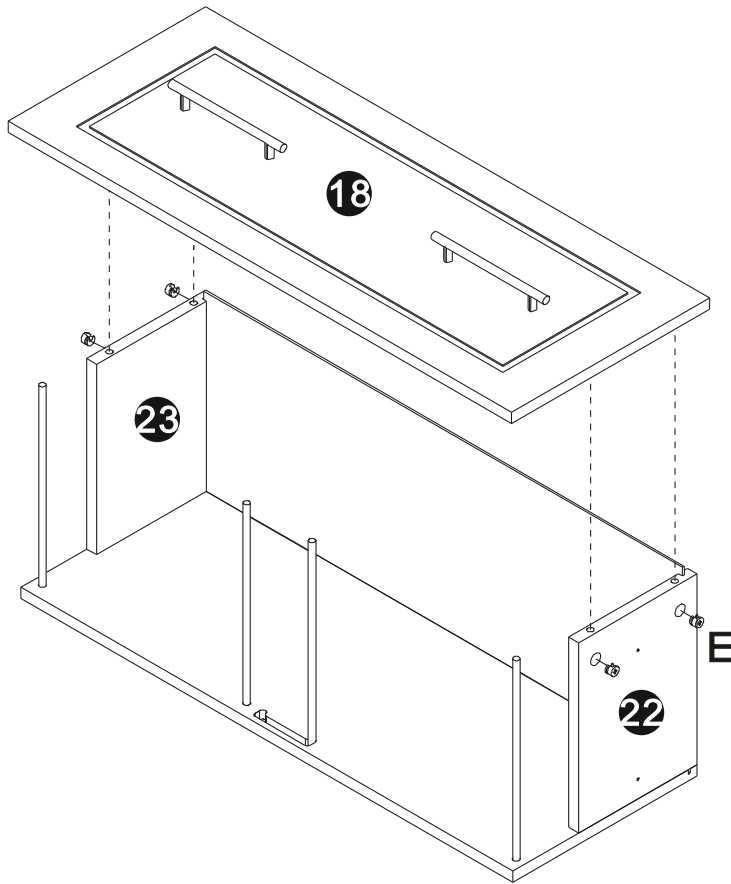

43

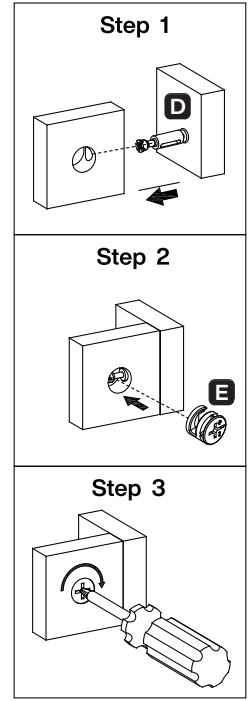

E

Ø15mm
4 pcs

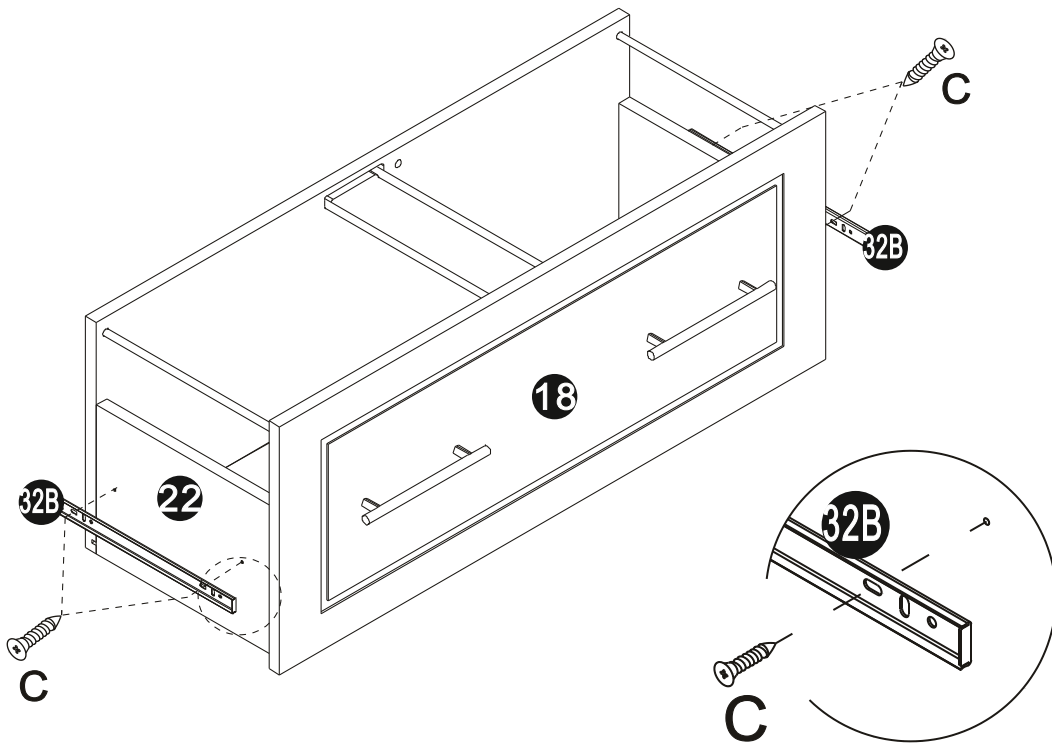

44



C

M3.5x14mm
4 pcs

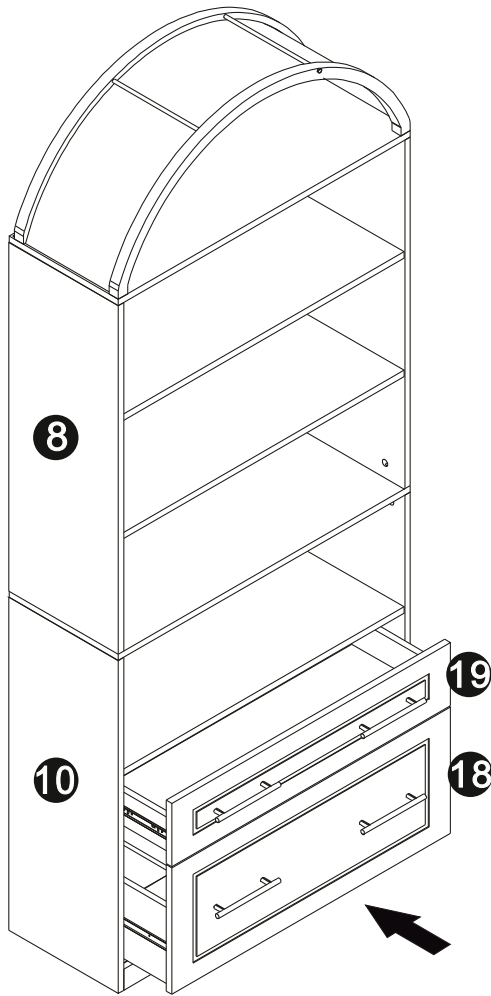
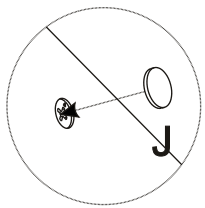
45

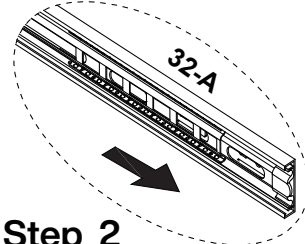

Step 1



Step 2

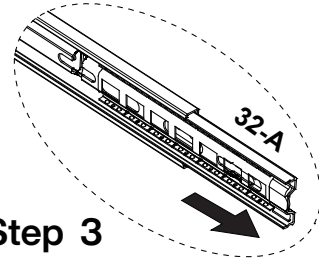

Step 3

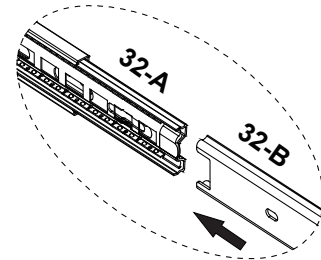

J
Ø21mm
24 pcs

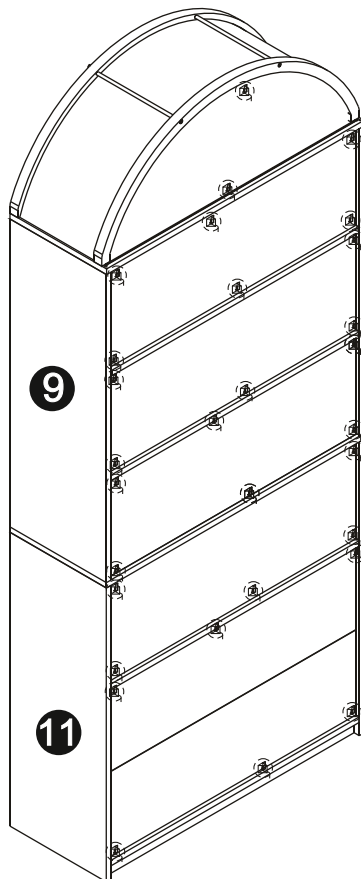

Before installation, slide the inner iron pieces of #32-A to the outermost side. Then align it with #32-B and gently push it inward to complete the slide installation.

46

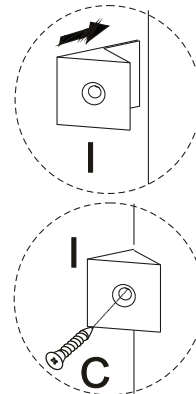

C	I
M3.5x14mm	
30 pcs	30 pcs



C	B	K
		
M3.5x14mm	M4x24.5mm	
2 pcs	2 pcs	2 pcs

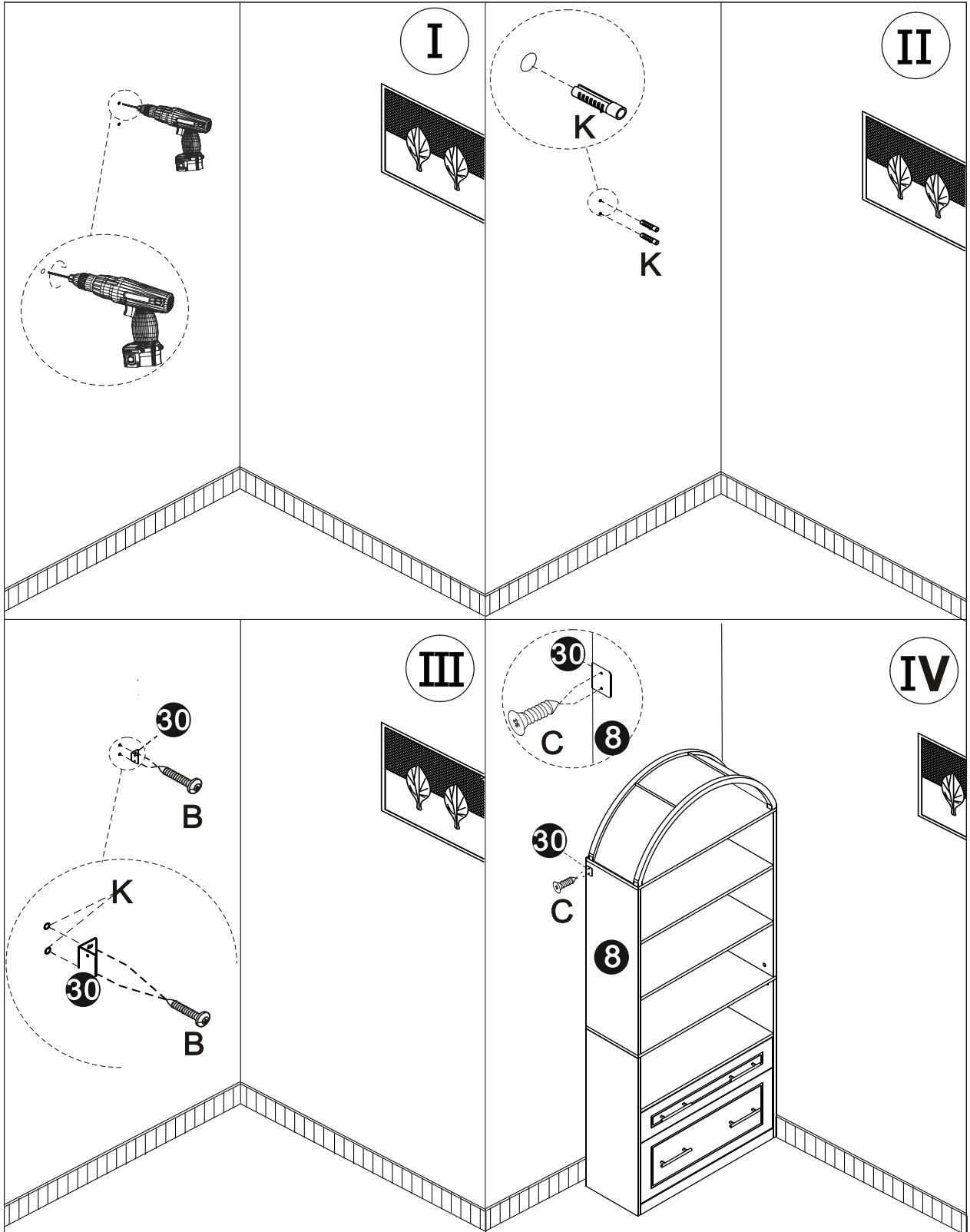

Thank you for your support!

