





# ASSEMBLY INSTRUCTIONS

## MODEL : DINING CHAIR

**IMPORTANT NOTE :**

- \* PLACE ALL WOODEN PARTS ON A CLEAN AND SMOOTH SURFACE SUCH AS A RUG OR CARPET TO AVOID THE PARTS FROM BEING SCRATCHED.
- \* BEFORE YOU BEGIN, KINDLY FOLLOW THE ASSEMBLY INSTRUCTIONS STEP BY STEP.
- \* DO NOT TIGHTEN ALL SCREWS UNTIL THE CHAIR IS FULLY SET-UP.

HARDWARE LIST		PART LIST	
A	JCBC M6 x 25mm + S/W M6 + F/W M6 x 13mm 	4PCS	1 LEG L/R 2PCS
B	JCBC M6 x 55mm + S/W M6 + F/W M6 x 13mm 	4PCS	2 TOP REST 1PC
C	JCBC W SCREW M7 x 40mm 	1PC	3 CHUSION SEAT 1PC
D	FH SCREW #8 x 25mm 	16PCS	4 CORNER BLOCK (LONG) 2PCS
E	ALLEN KEY M4 	1PC	5 CORNER BLOCK (SHORT) 2PCS

### CAUTIONS :

(1) DO NOT FULLY-TIGHTEN THE NUT OR NUT BOLTS INITIALLY UNTIL ALL NUTS OR BOLT IS READY ASSEMBLED.

(TO AVOID CAUSING DAMAGES TO THE THREAD, DO NOT OVER-TIGHTEN THE NUTS OR BOLTS.)

(2) KEEP ALL HARDWARE PART OUT OF REACH OF CHILDREN.

### STEP 1

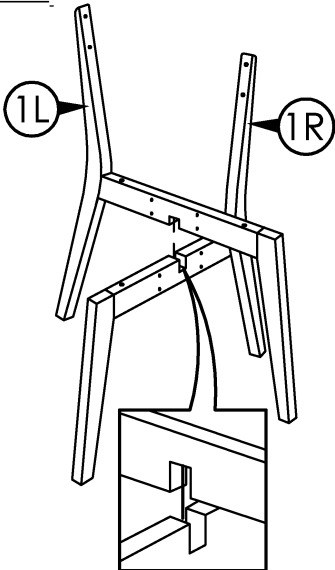

### STEP 2

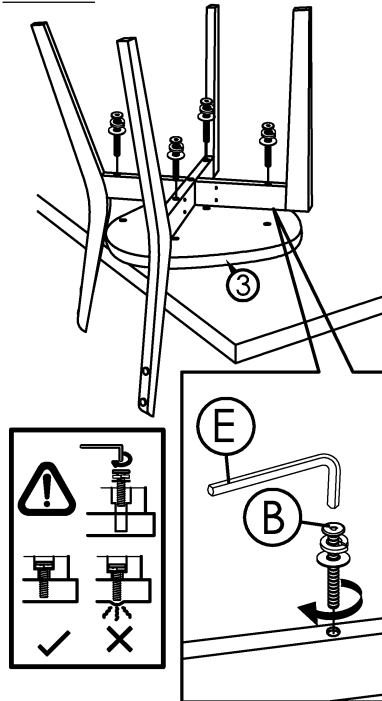

### STEP 3

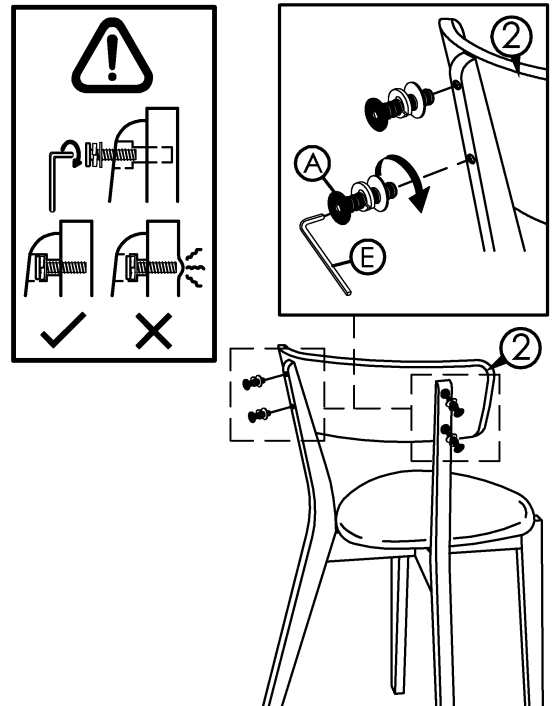

### STEP 4

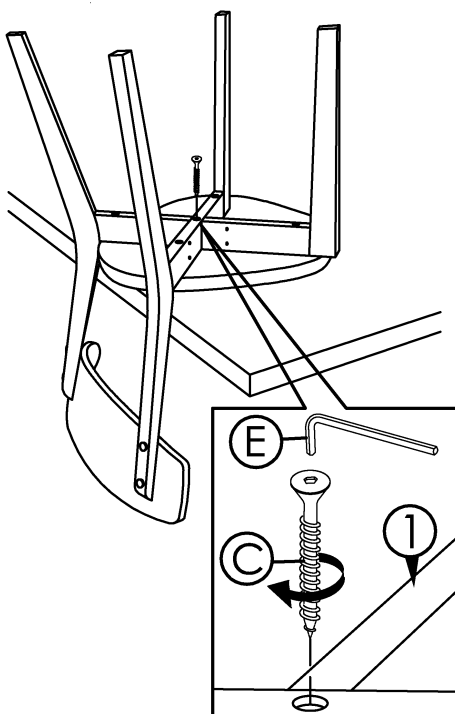

### STEP 5

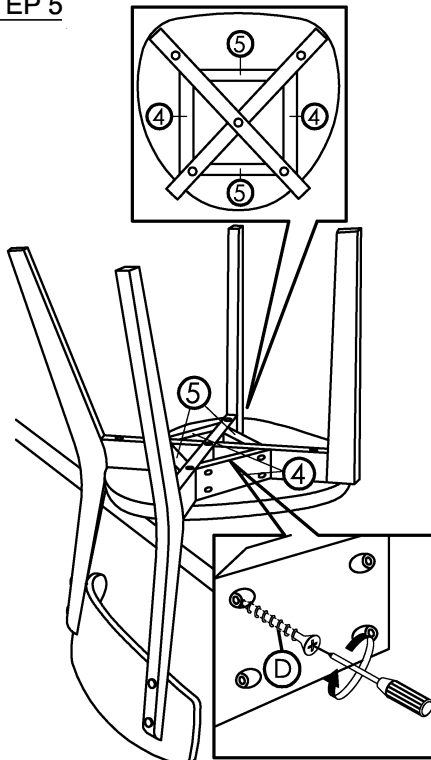

### STEP 6

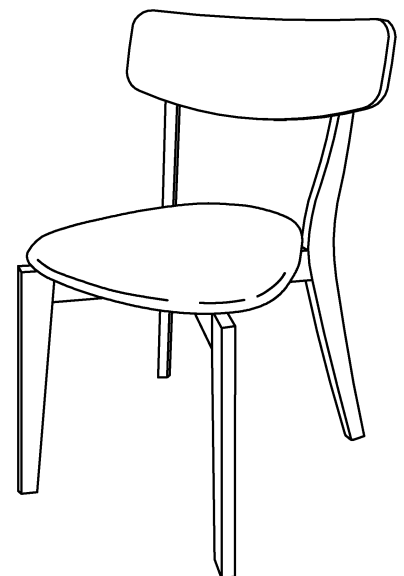

COMPLETED CHAIR ASSEMBLY.

# ASSEMBLY INSTRUCTIONS

## MODEL : RECTANGLE DINING TABLE

### IMPORTANT NOTE :

- \* PLACE ALL WOODEN PARTS ON A CLEAN AND SMOOTH SURFACE SUCH AS A RUG OR CARPET TO AVOID THE PARTS FROM BEING SCRATCHED.
- \* BEFORE YOU BEGIN, KINDLY FOLLOW THE ASSEMBLY INSTRUCTIONS STEP BY STEP.

### HARDWARE LIST

A	JCBB M8 x 80mm + S/W 5/16" + F/W 5/16" x 22mm	8PCS
B	ALLEN KEY M5	1PC

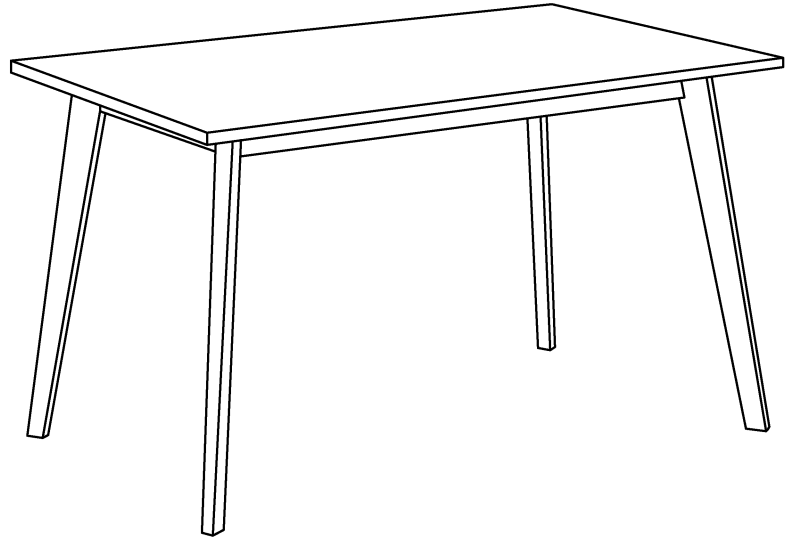

COMPLETED TABLE ASSEMBLY.

### PART LIST

1	TABLE TOP	1PC
2	TABLE LEG	4PCS

