

ASSEMBLY INSTRUCTIONS

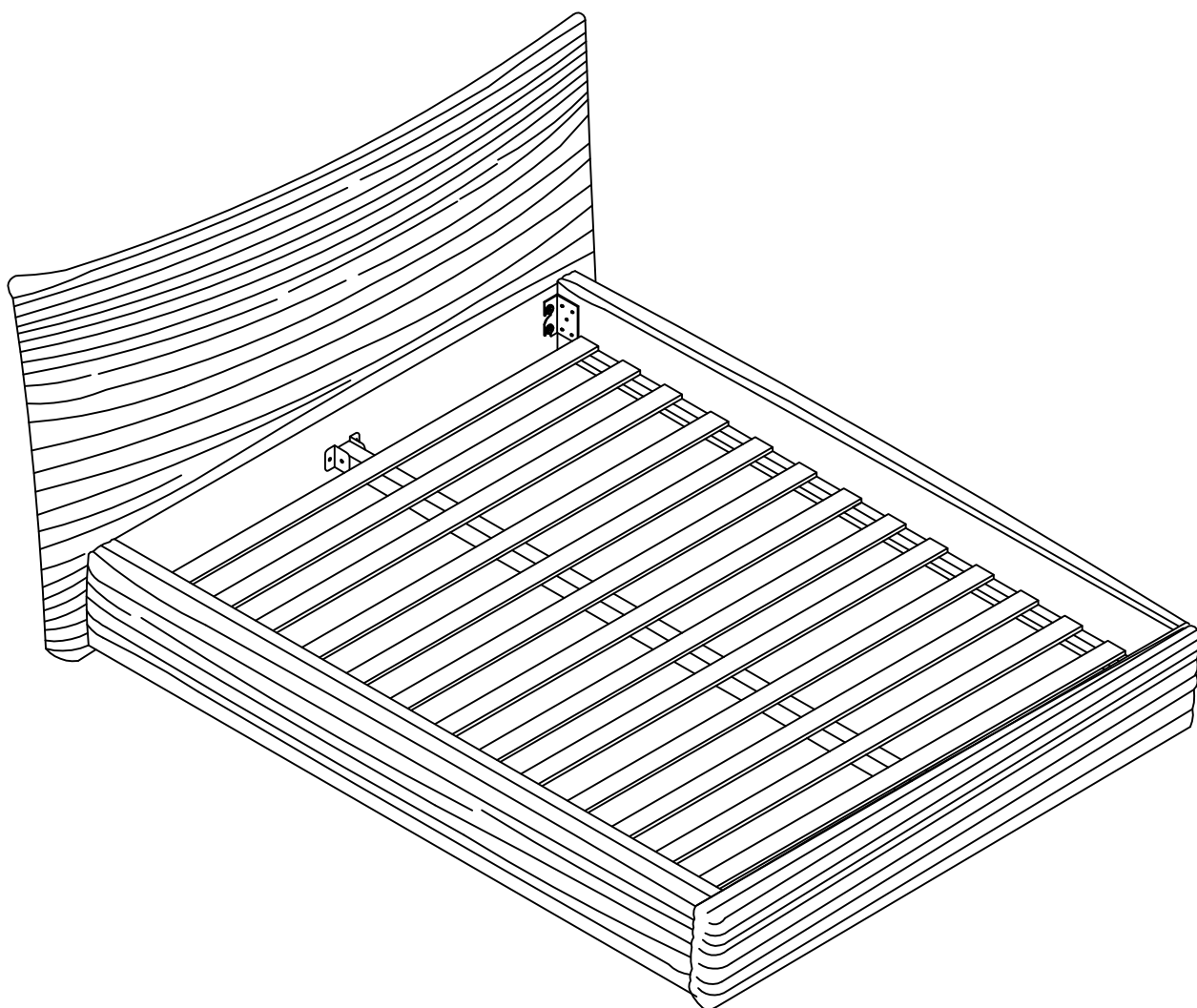

Install all screws according to the instructions, and then tighten them completely.

NOTE: The slats are stored at the bottom of Section A

STEP :Packing Details

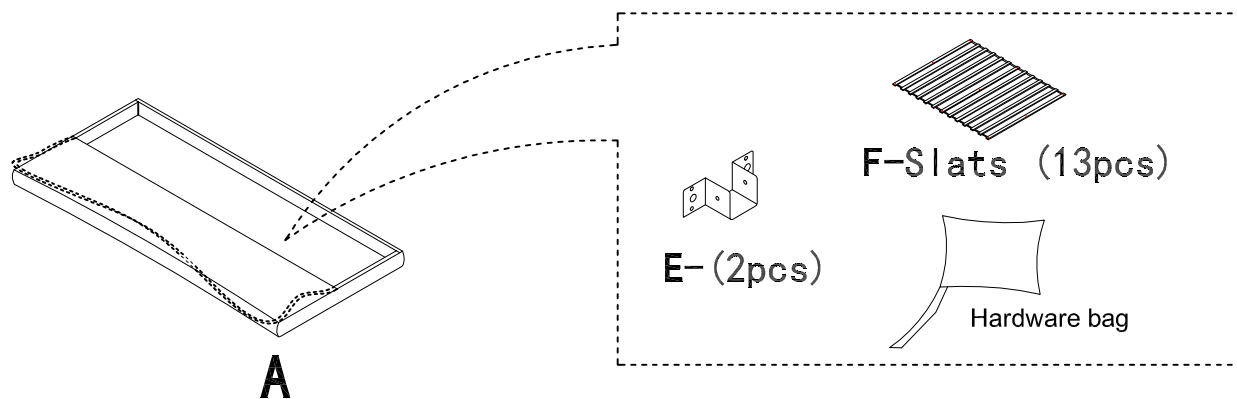

PARTS AND HARDWARE

Parts List

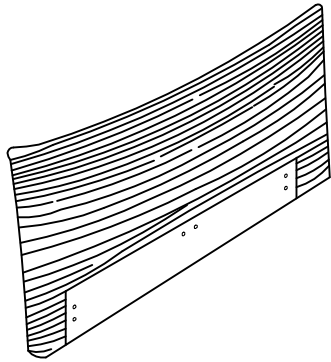

A-HeadBoard (1pc)

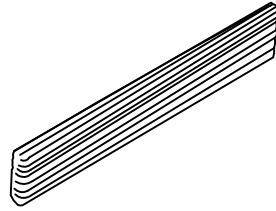

B-Foot Board (1pc)

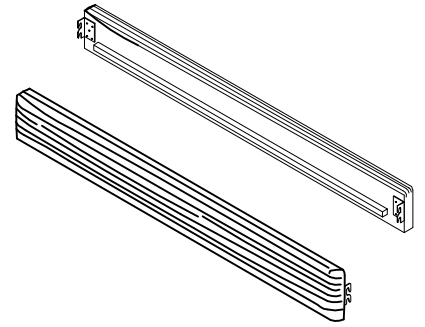

C-Side Rails (2pcs)

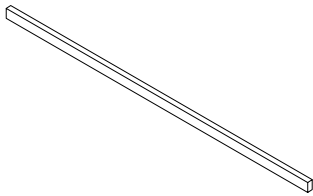

D-Center Support Bar (1pc)

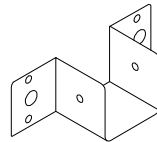

E- (2pcs)

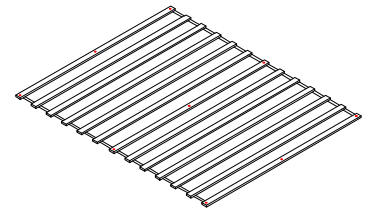

F-Slats (13pcs)

HARDWARE LIST:

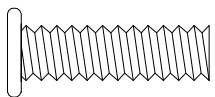

m8*30
1 -Bolt (8pcs)

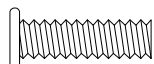

m6*25
2 -Bolt (4pcs)



m8
3 -Spring Washer (8pcs)

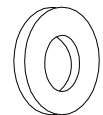

m8*16
4 -Flat Washer (8pcs)



m6*16
5 -Flat Washer (4pcs)

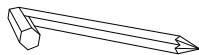

m8
6 -Allen Key (1pcs)





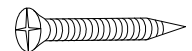





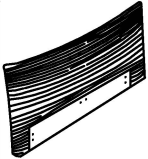

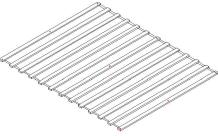
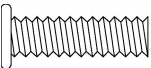
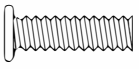
m6
7 -Allen Key (1pcs)

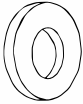

M4*25
8 - Screw (9pcs)

PACKING DETAILS: TOTAL 2 BOXES

BOX- 1/2	
PART	
	A-HeadBoard (1pc)
	B-Foot Board (1pc)
	E- (2pcs)
	F-Slats (13pcs)
	m8*30 1 -Bolt (8pcs)
	m6*25 2 -Bolt (4pcs)
	m8 3 -Spring Washer (8pcs)
	m8*16 4 -Flat Washer (8pcs)
	m6*16 5 -Flat Washer (4pcs)
	m8 6 -Allen Key (1pc)
	m6 7 -Allen Key (1pc)
	M4*25 8 - Screw (9pcs)

BOX-2/2	
PART	
	C-Side Rails (2pcs)
	D-Center Support Bar (1pc)

ASSEMBLY INSTRUCTIONS

STEP 1:



m8*30
1 -Bolt (8pcs)



3 -Spring Washer
(8 pcs)



m8*16
4 -Flat Washer
(8pcs)

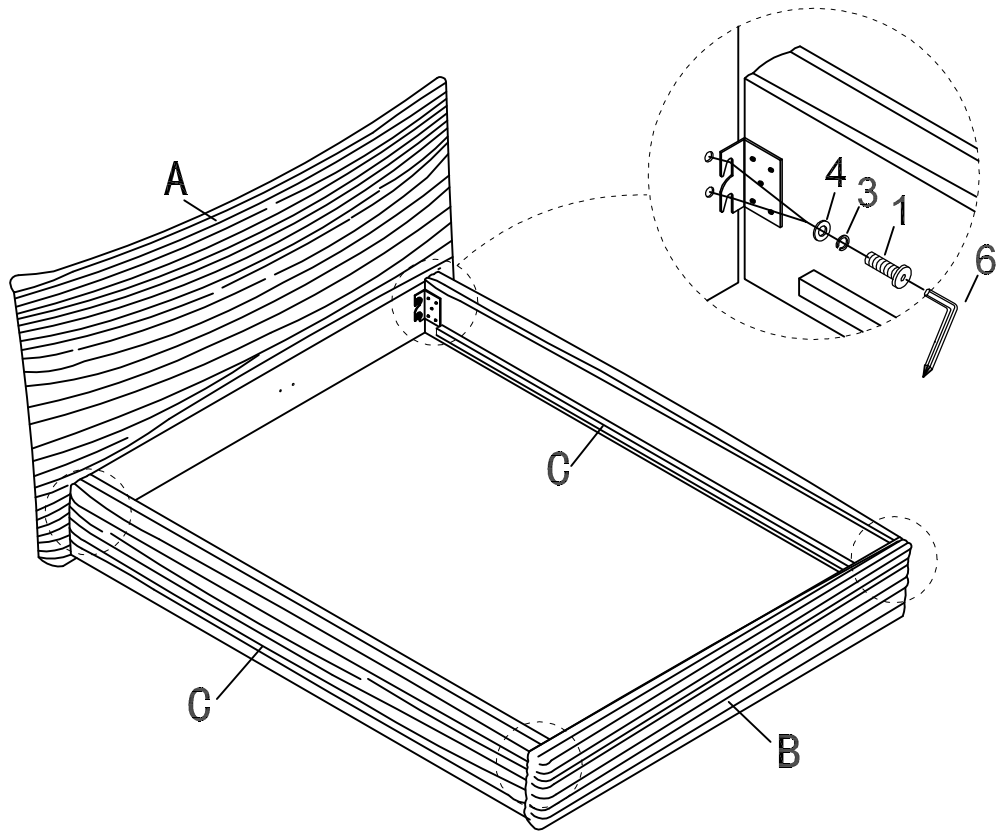

STEP 2:



m6*25
2 -Bolt (4pcs)



m6*16
5 -Flat Washer
(4pcs)



E- (2pcs)

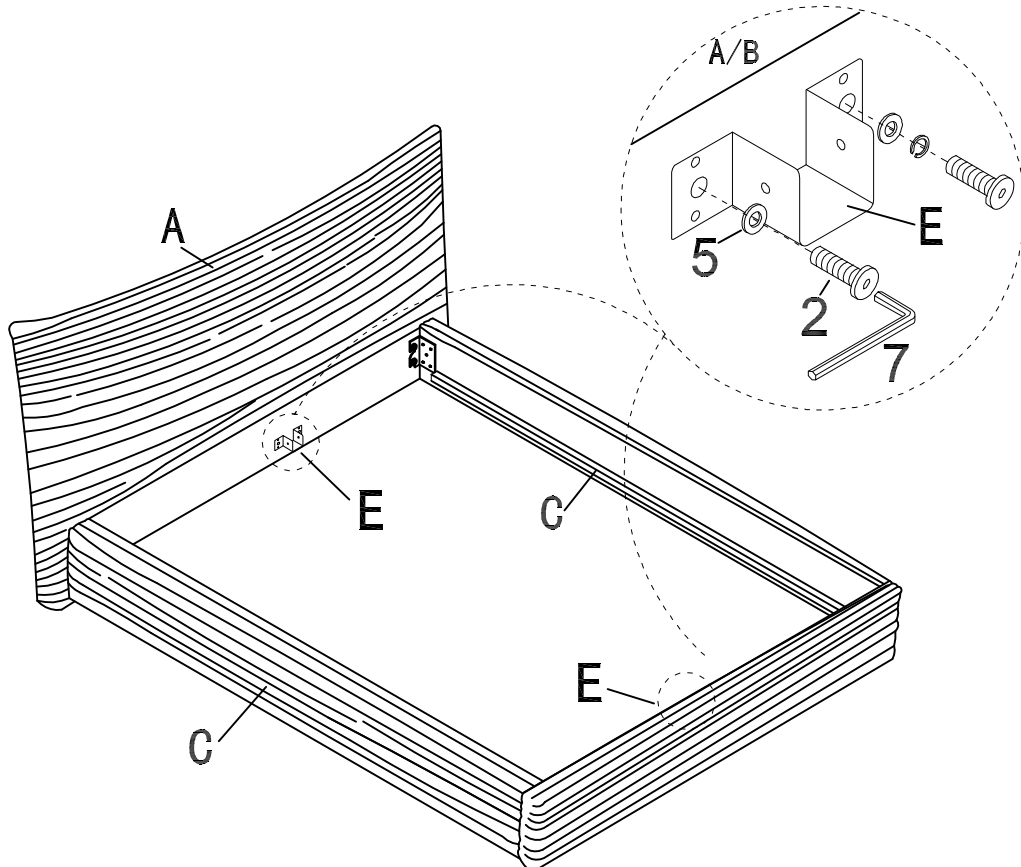

ASSEMBLY INSTRUCTIONS

STEP 3:

F-Slats (13pcs)

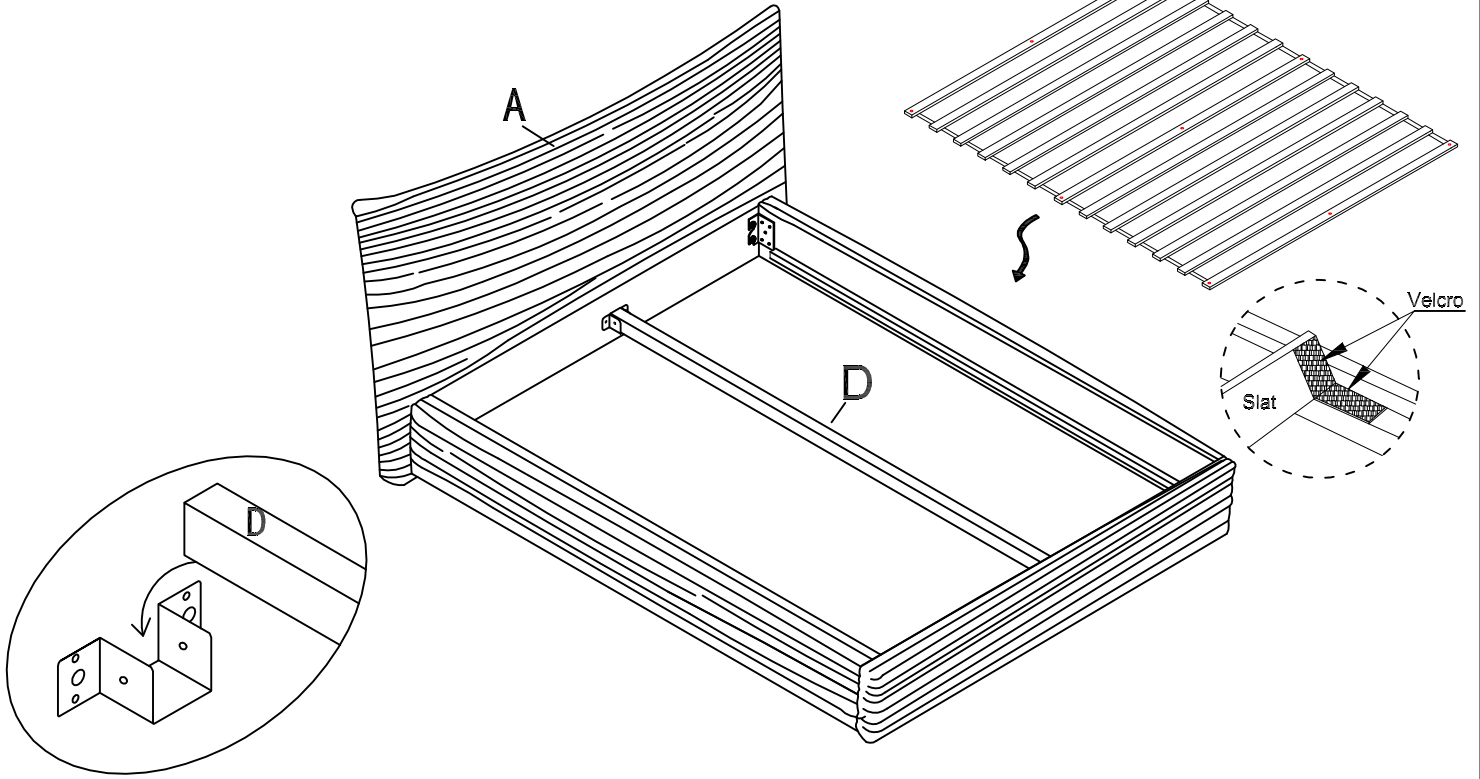

STEP 4:

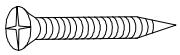

M4*25

8 - Screw (9pcs)

