

ASSEMBLY INSRTRUCTION INSTRUCTION d' ASSEMBLAGE

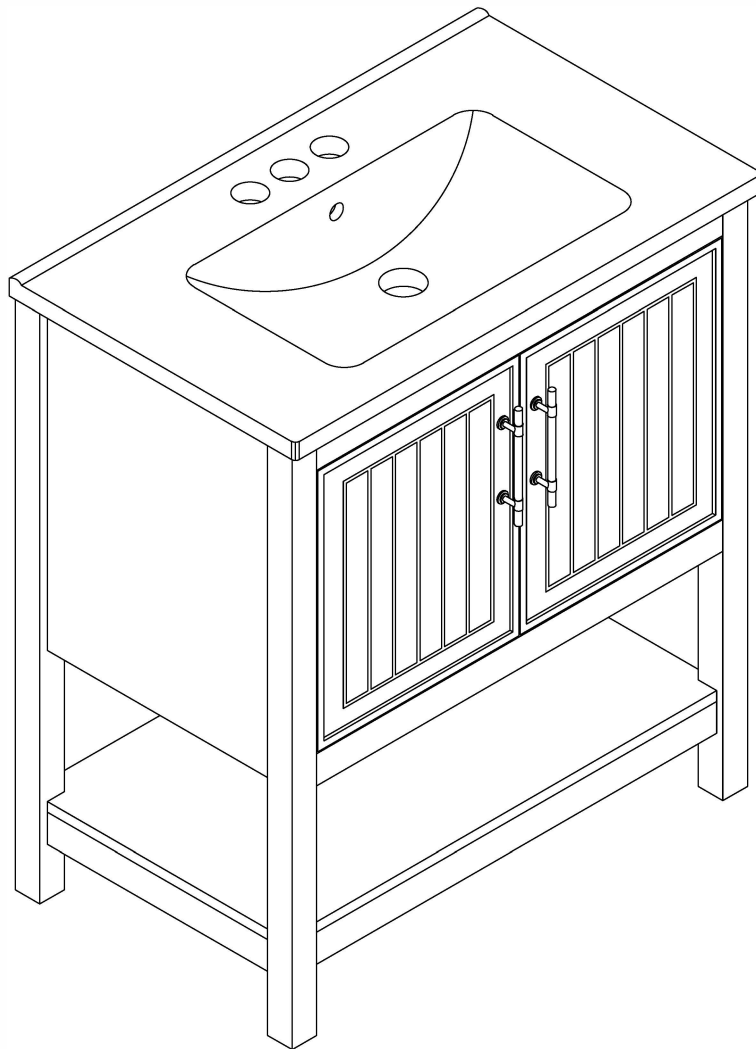







Before Installation

Important-Please read these instructions fully before starting assembly

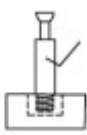
Thank you for purchasing this quality product. Be sure to check all packing materials carefully for small parts, which may have come loose inside the carton during shipment. Identify and count all items according to the PARTS LIST and/or HARDWARE LIST shown below. Check you have all the components and tools listed on the following pages.

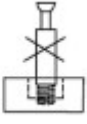
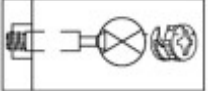
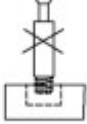
- We recommend that you assemble this product with the assistance of another person; this will make the assembly easier, and will help eliminate damage to the product or injury to persons during assembly.
- Please do not over tighten screws or bolts until the assembly is completed.
- Keep children and animal away from the work area, small parts could choke if swallowed. Please put all parts on a non-abrasive floor before assembly, and follow the assembly steps to assemble your newly purchased product correctly and efficiently.

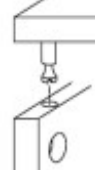
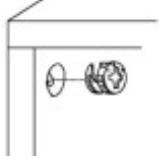
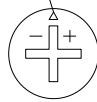
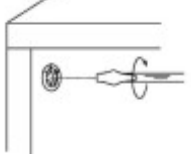
Cam Lock Assembly Instructions

		Insert Cam Bolt into hole as shown in diagram A.
		Make sure not to insert the Cam Bolt: Too deep as shown in figure B as this will cause the Cam Lock to be misaligned and unable to interlock properly.
		Also avoid inserting the Cam Bolt too close to the surface of the hole as shown in figure C, as this will cause the Cam Lock to be too loose, and not interlock properly.
		Connect the panels together.
		Insert the Cam Lock so the side opening fits over the head of the Cam Bolt.
		To tighten the Cam Lock, turn it clockwise on half a turn with a flat screwdriver. *Do not use an automatic screwdriver as it may bend or break if too much power is imposed.





Avant l'installation

Important - Veuillez lire attentivement ces instructions avant de commencer l'assemblage

Merci d'avoir acheté ce produit de qualité. Assurez-vous de vérifier attentivement tous les matériaux d'emballage pour des petites pièces qui auraient pu se détacher à l'intérieur du carton pendant le transport. Identifiez et comptez tous les articles selon la LISTE DES PIÈCES et/ou la LISTE DE QUINCAILLERIE ci-dessous. Vérifiez que vous avez tous les composants et outils répertoriés sur les pages suivantes.

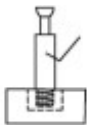
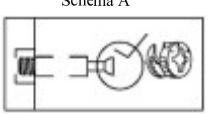
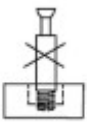
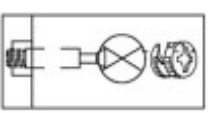
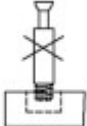
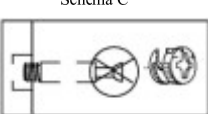
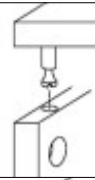
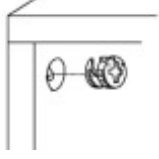
- Nous vous recommandons d'assembler ce produit avec l'aide d'une autre personne : cela facilitera l'assemblage et aidera à éviter d'endommager le produit ou de blesser des personnes pendant l'assemblage.
- Veuillez ne pas trop serrer les vis ou les boulons avant que l'assemblage ne soit terminé.
- Gardez les enfants et les animaux à l'écart de la zone de travail, car les petites pièces peuvent présenter un risque d'étouffement si elles sont avalées. Veuillez placer toutes les pièces sur un sol non abrasif avant l'assemblage et suivez les étapes d'assemblage pour assembler votre produit correctement et efficacement.

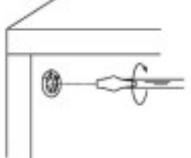
Instructions d'assemblage des verrous à came

		Insérez le boulon à came dans le trou comme indiqué sur le schéma A.
		Assurez-vous de ne pas insérer le boulon à came trop profondément comme indiqué sur la figure B, car cela entraînerait un mauvais alignement du verrou à came et empêcherait son bon enclenchement.
		Évitez également d'insérer le boulon à came trop près de la surface du trou comme indiqué sur la figure C, car cela rendrait le verrou à came trop lâche et empêcherait son bon enclenchement.
		Assemblez les panneaux ensemble.
		Insérez le verrou à came de manière à ce que l'ouverture latérale s'adapte à la tête du boulon à came.
		Pour serrer le verrou à came, tournez-le dans le sens des aiguilles d'une montre d'un demi-tour à l'aide d'un tournevis plat. *"Ne pas utiliser de tournevis automatique, car il pourrait se plier ou se casser si une force excessive est appliquée."

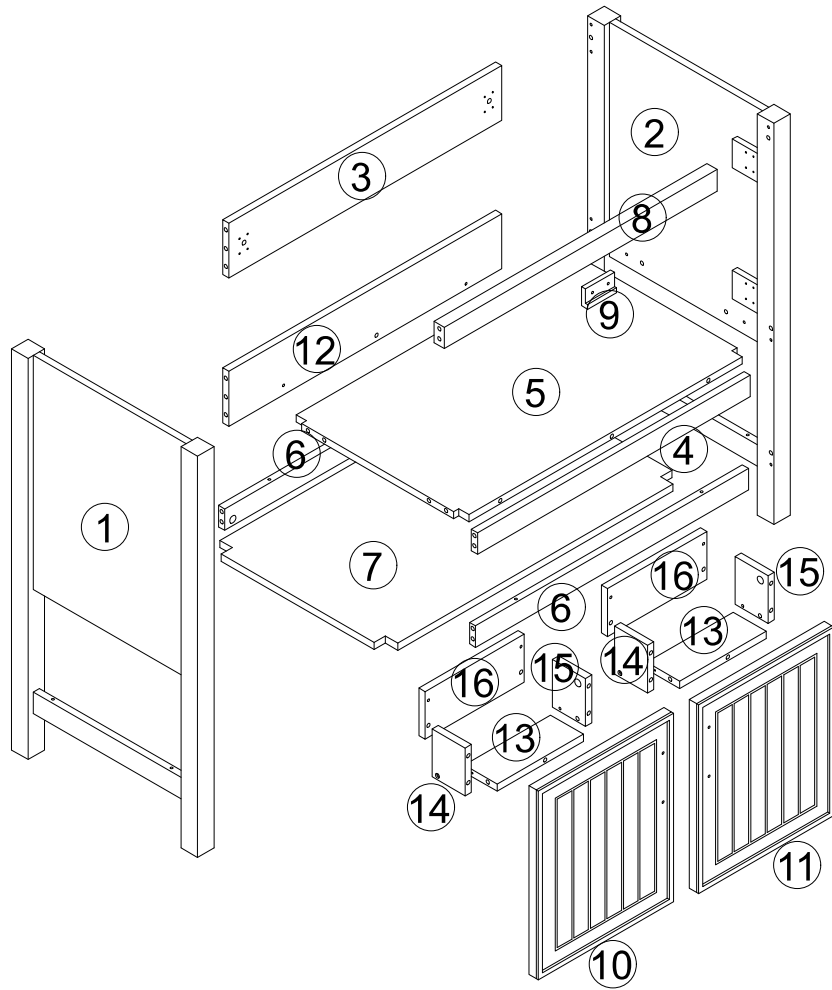

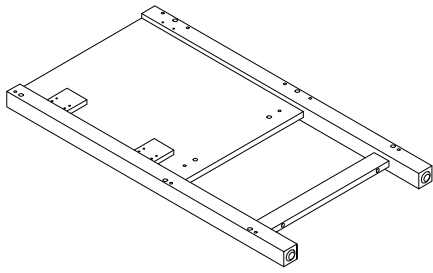

① x 1

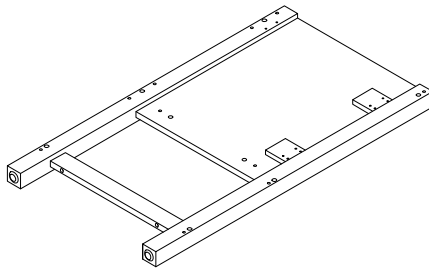

② x 1

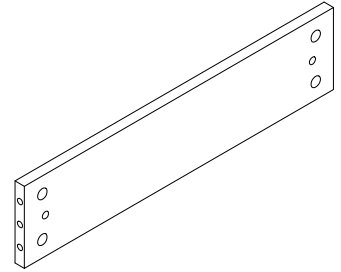

③ x 1

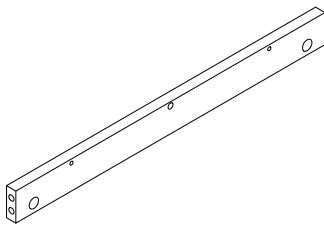

④ x 1

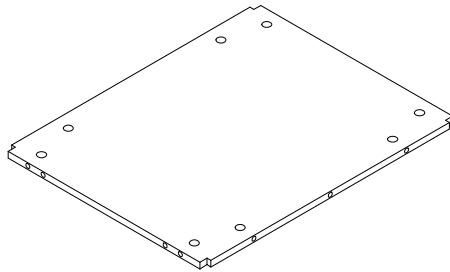

⑤ x 1

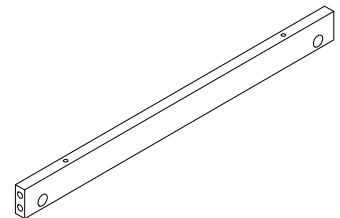

⑥ x 2

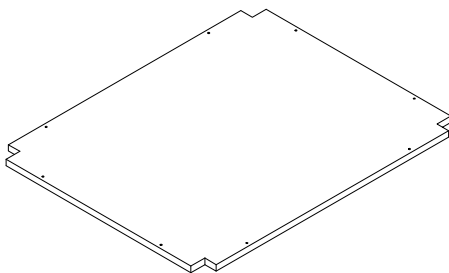

⑦ x 1

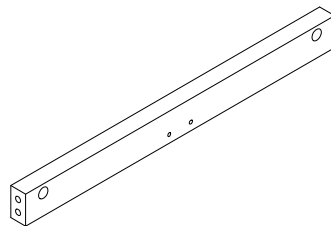

⑧ x 1



⑨ x 1

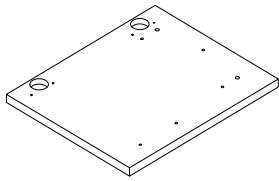

⑩ x 1

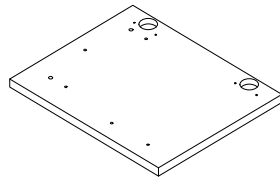

⑪ x 1

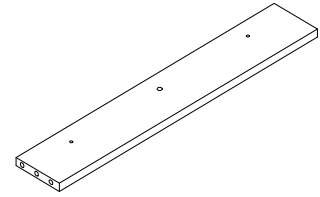

⑫ x 1



⑬ x 2



⑭ x 2



⑮ x 2

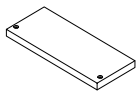

⑯ x 2

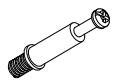

Φ6x35mm
A x 30+2



Φ15x12mm
B x 30+2

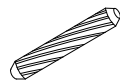

Φ8x30mm
C x 30+2



Φ4x35mm
D x 8

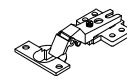

E x 4



M4x14mm
F x 24+2



M4x22mm
G x 4

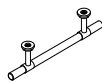

H x 2



M4x25mm
I x 2



M4x35mm
J x 8

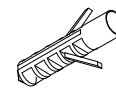

Φ8x40mm
K x 2



M6x60mm
L x 2



Φ4x14mm
M x 12+1



N x 2



O x 4

Step1 / étape 1

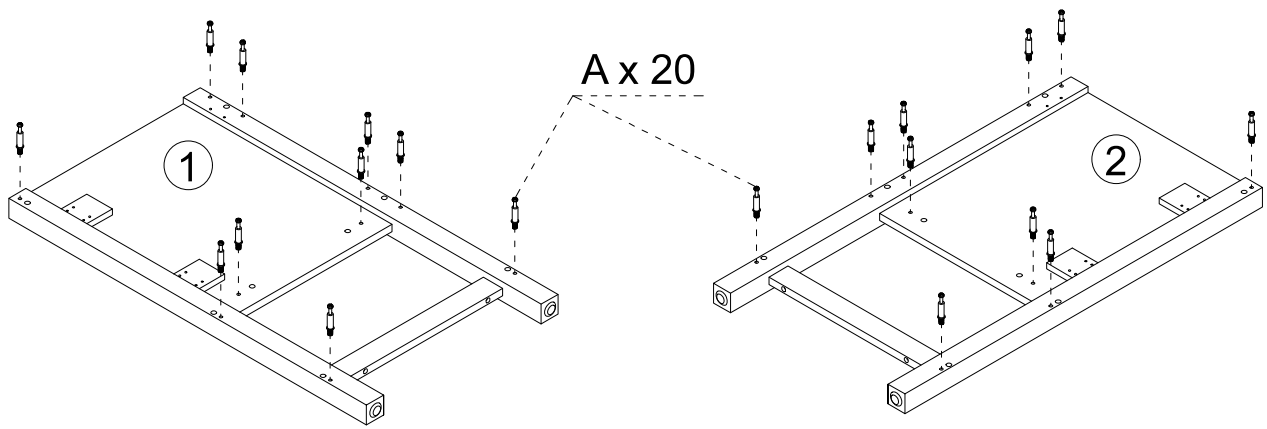



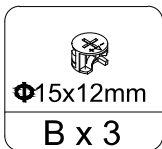
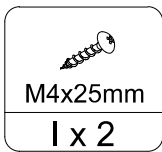
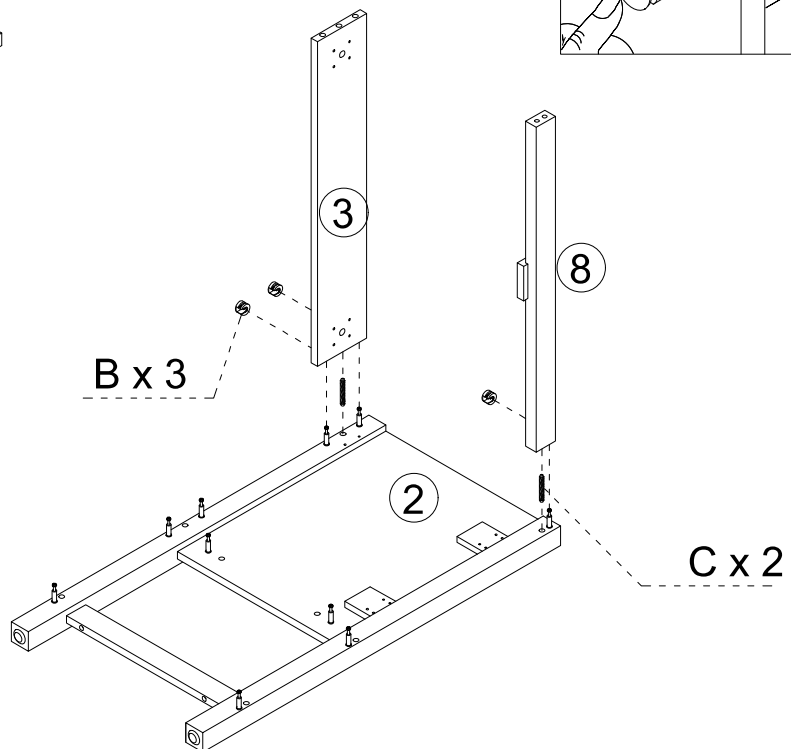
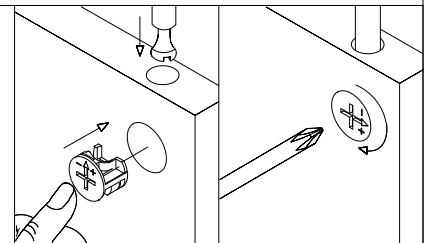
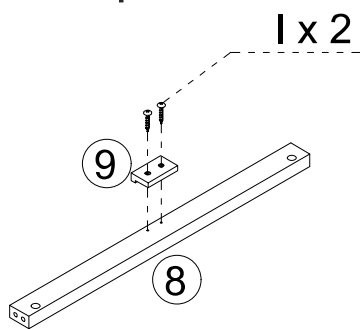

Step 2/ étape 2

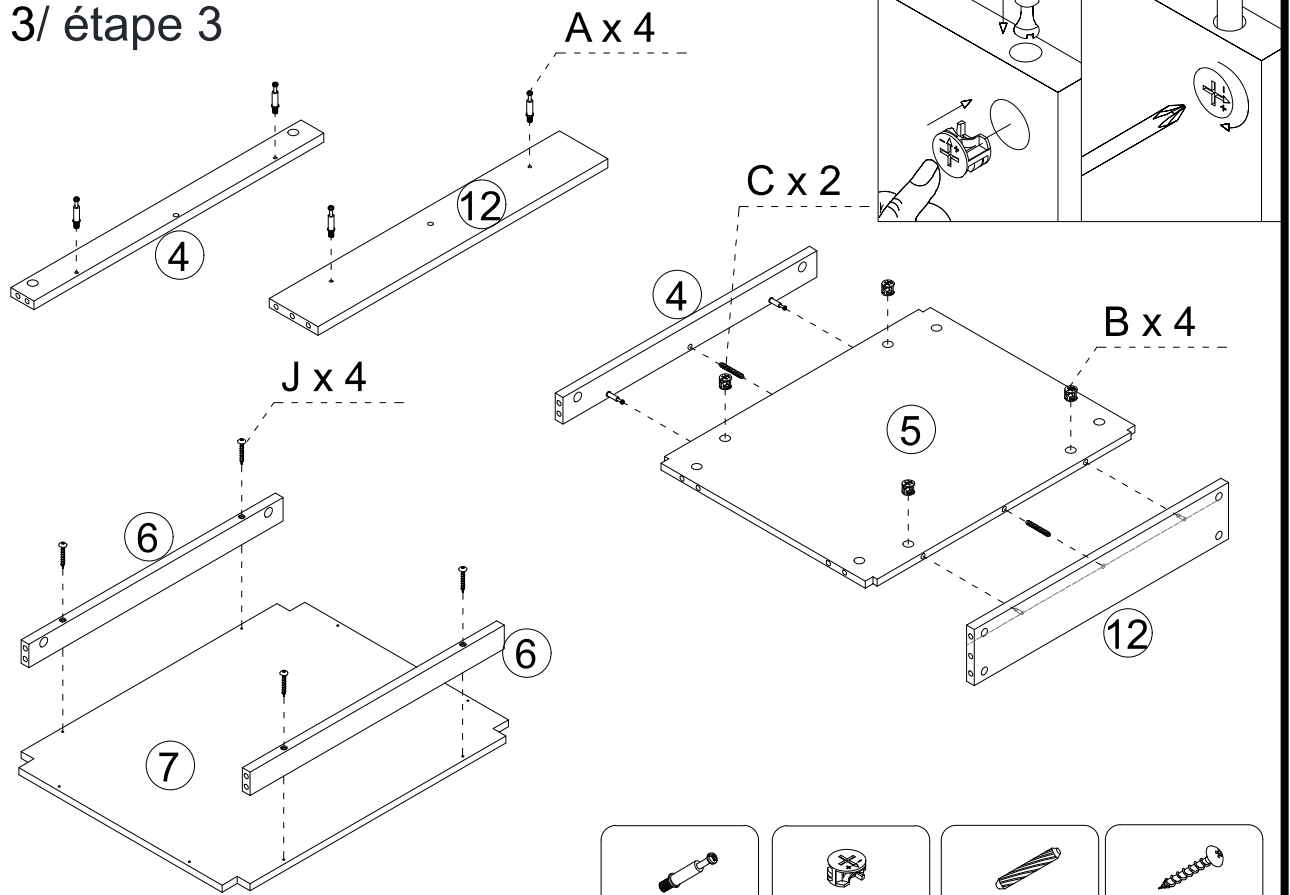

Step 3/ étape 3



 Φ6x35mm A x 4	 Φ15x12mm B x 4	 Φ8x30mm C x 2	 M4x35mm J x 4
--	---	--	--

Step 4/ étape 4

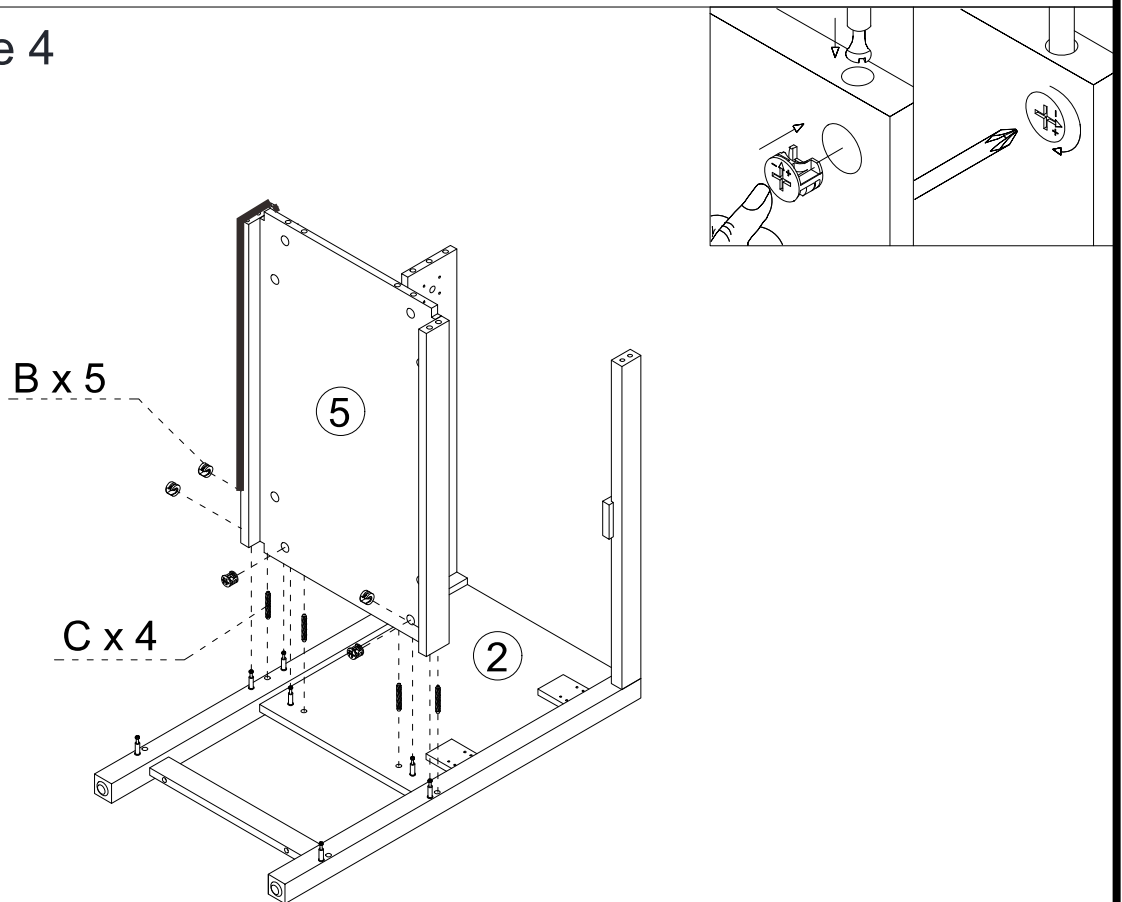

 Φ8x30mm C x 4

 Φ15x12mm B x 5
--

Step 5/ étape 5

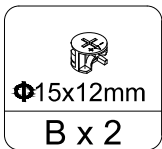
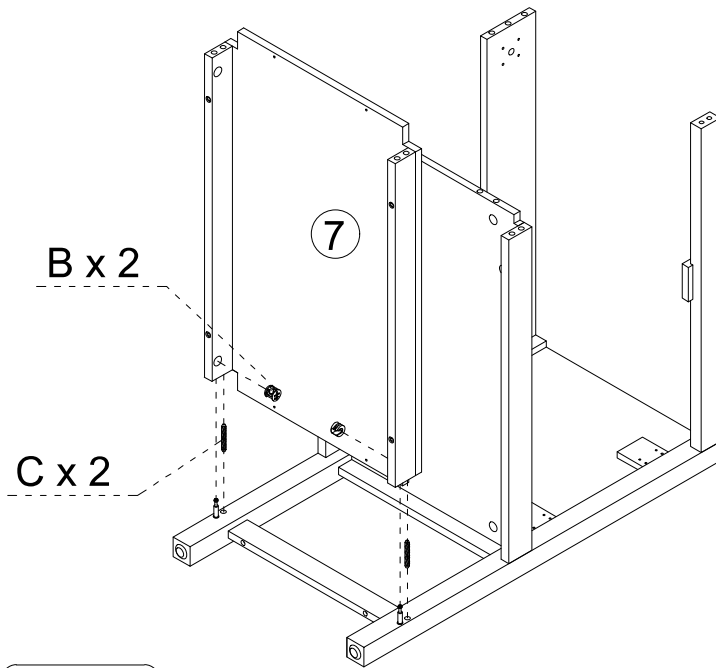
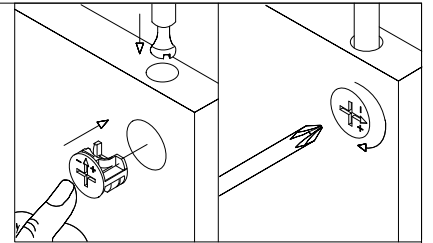

Step 6/ étape 6

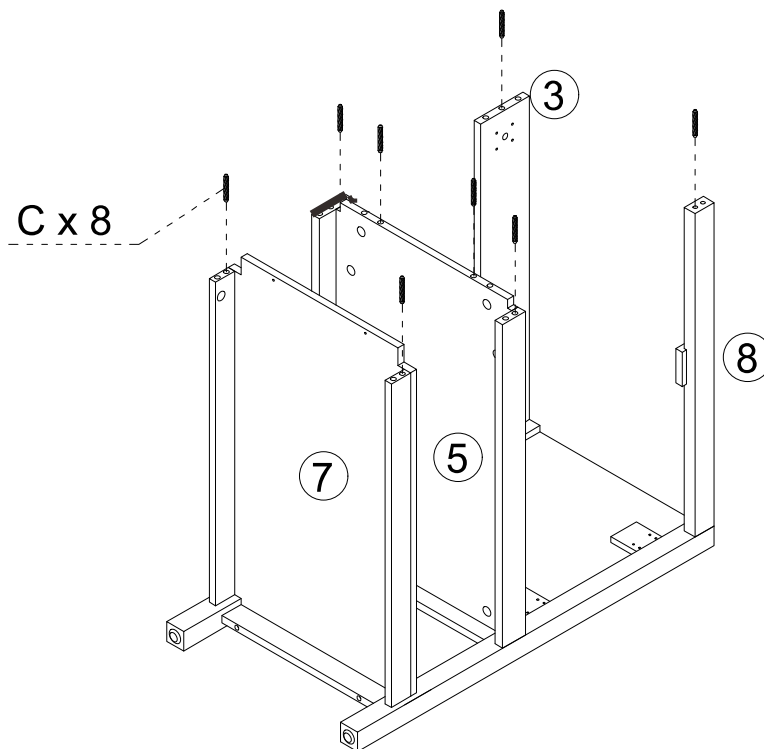

Step 7/ étape 7

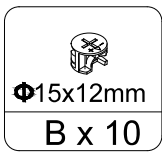
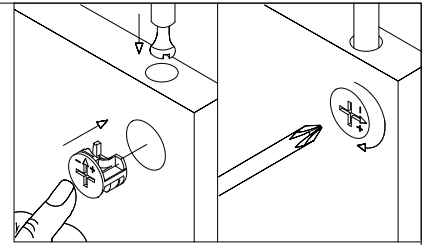
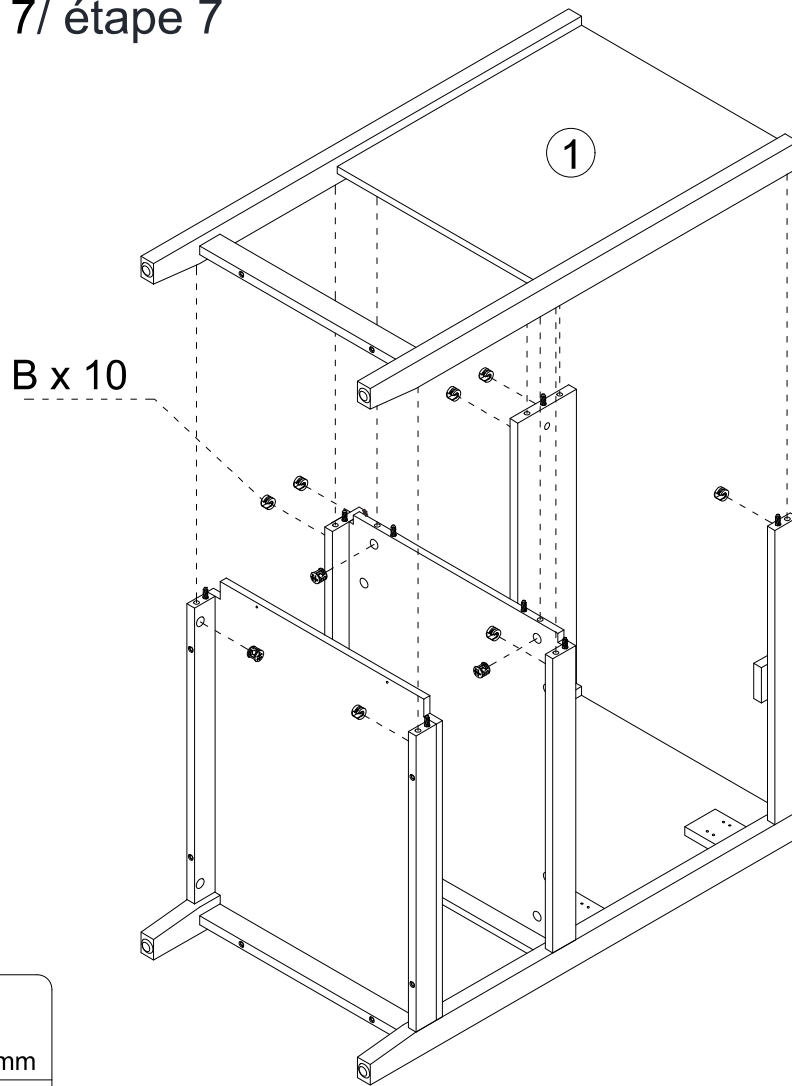

Step 8/ étape 8

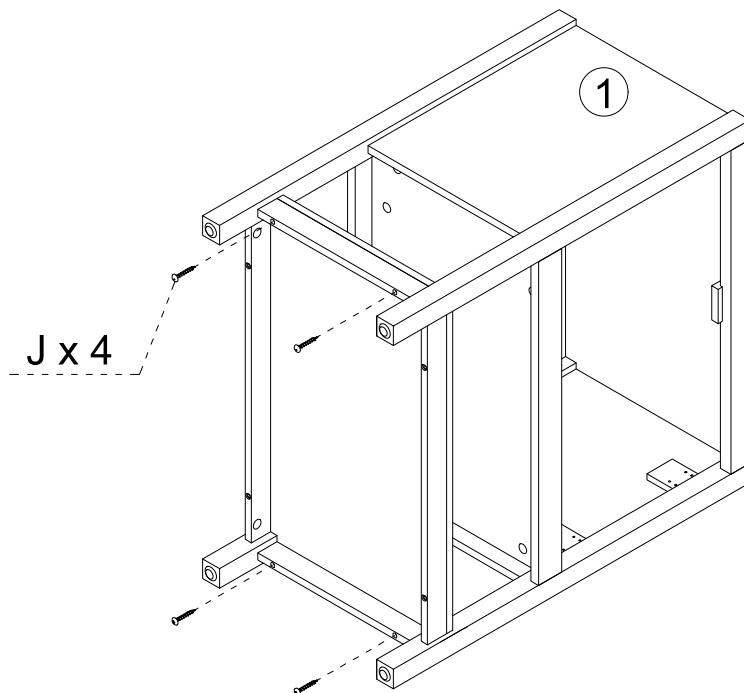

Step 9/ étape 9

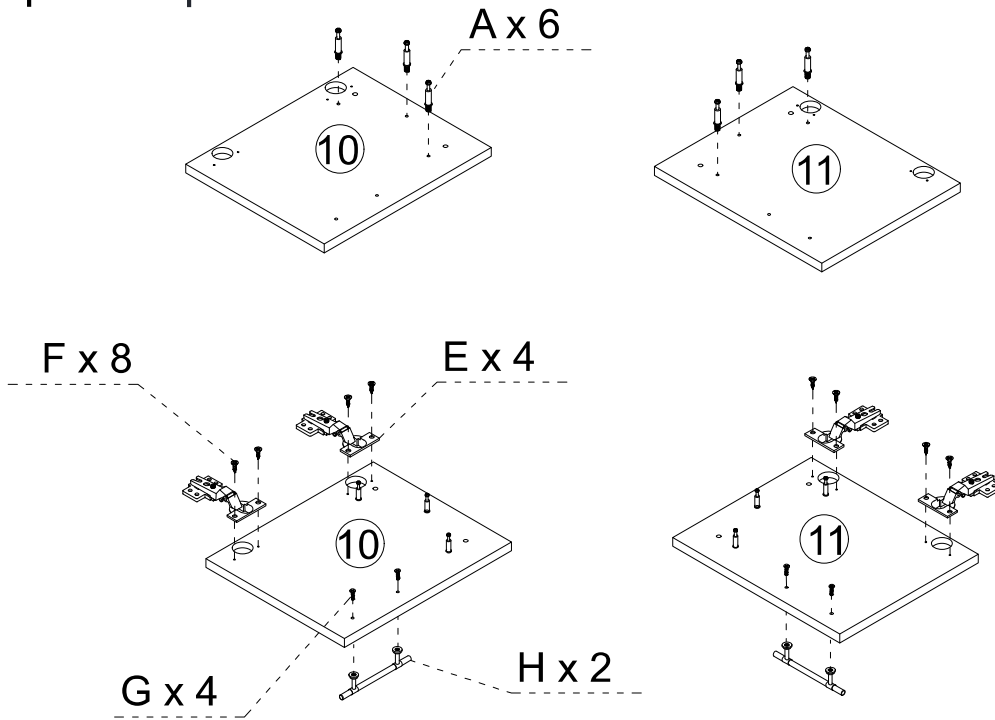

 Φ6x35mm A x 6	 E x 4	 M4x14mm F x 8	 M4x22mm G x 4	 H x 2
--	---	--	--	---

Step 10/ étape 10

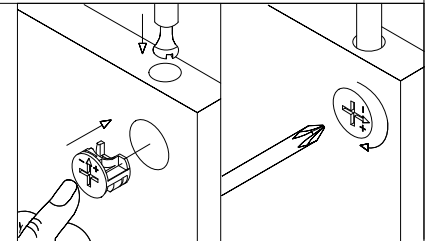
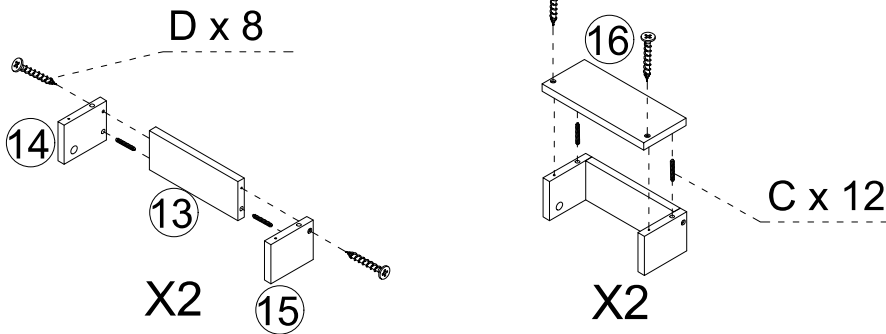

 Φ15x12mm B x 6	 Φ8x30mm C x 12	 Φ4x35mm D x 8
--	--	---

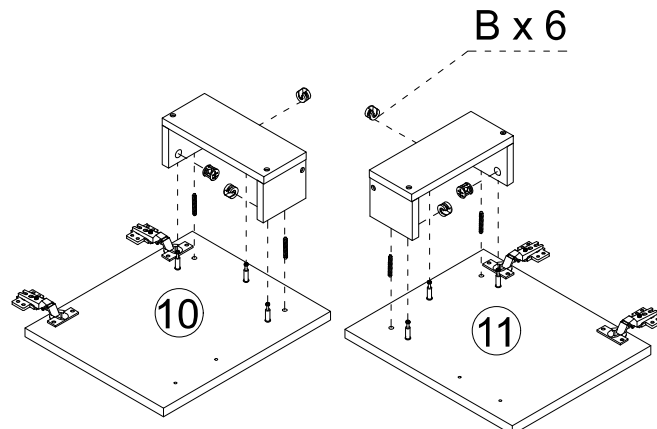

Step 11/ étape 11

SETTINGS DOORS/Configurer la porte

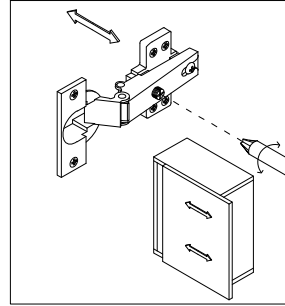
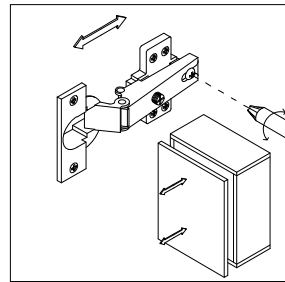
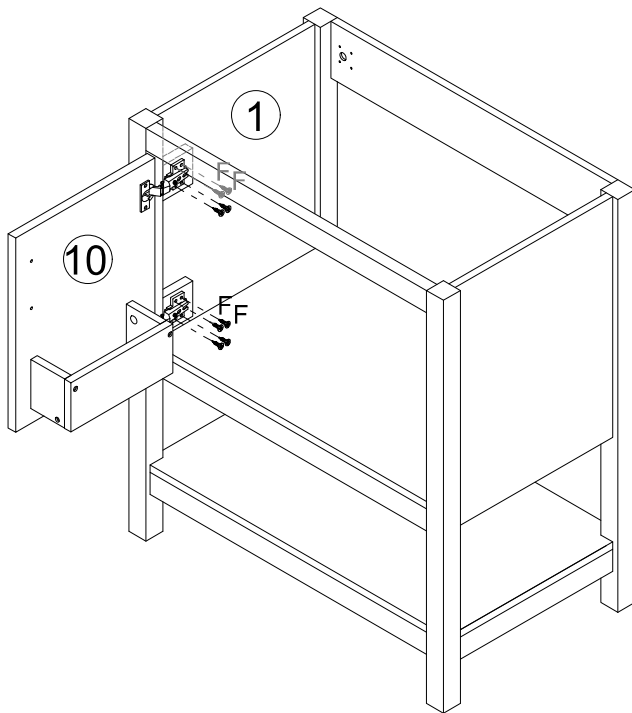

If the hinge holes are not aligned, you can try adjusting the front and rear hinges./Si les trous de charnière ne sont pas alignés, vous pouvez essayer d'ajuster les charnières avant et arrière.

If the door gap is large, you can adjust the hinges left and right/Si le jeu de porte est grand, les charnières peuvent être ajustées à droite et à gauche

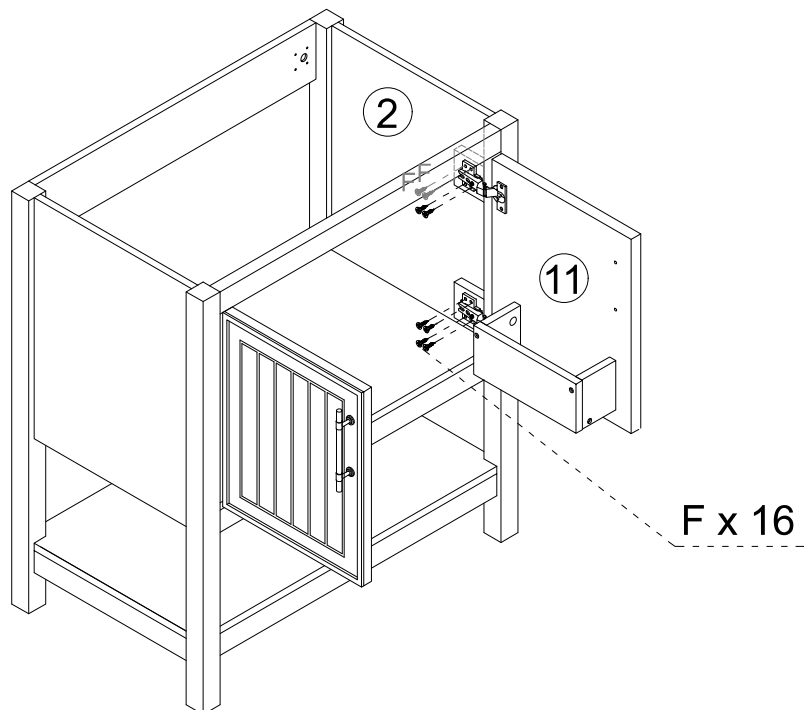

M4x14mm

F x 16

Step 12/ étape 12

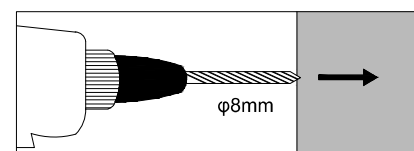
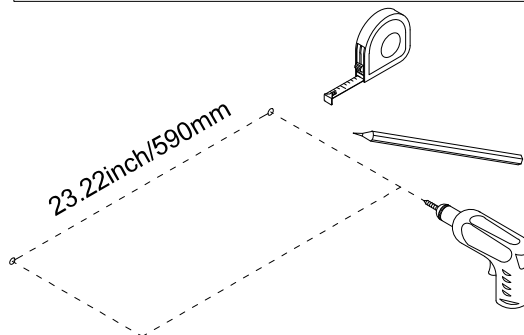
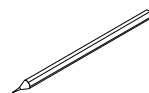

Step 13/ étape 13

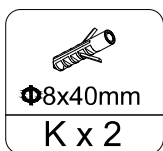
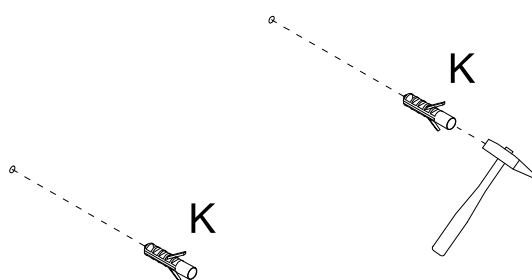
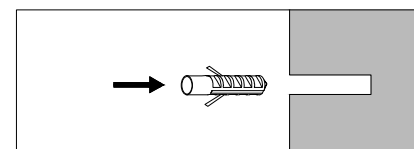

Step 14/ étape 14

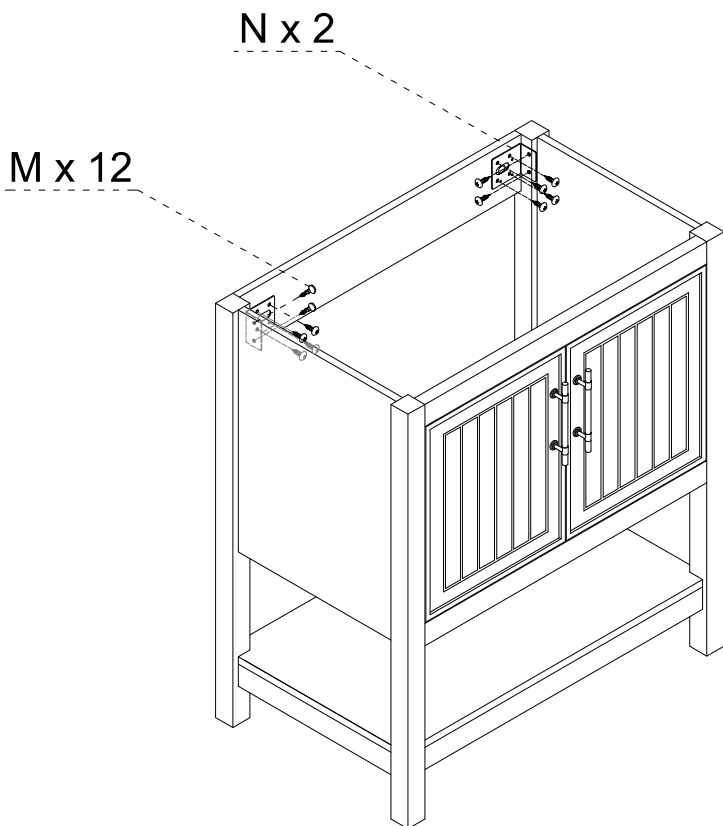

Φ4x12mm
M x 12



N x 2

Step 15/ étape 15

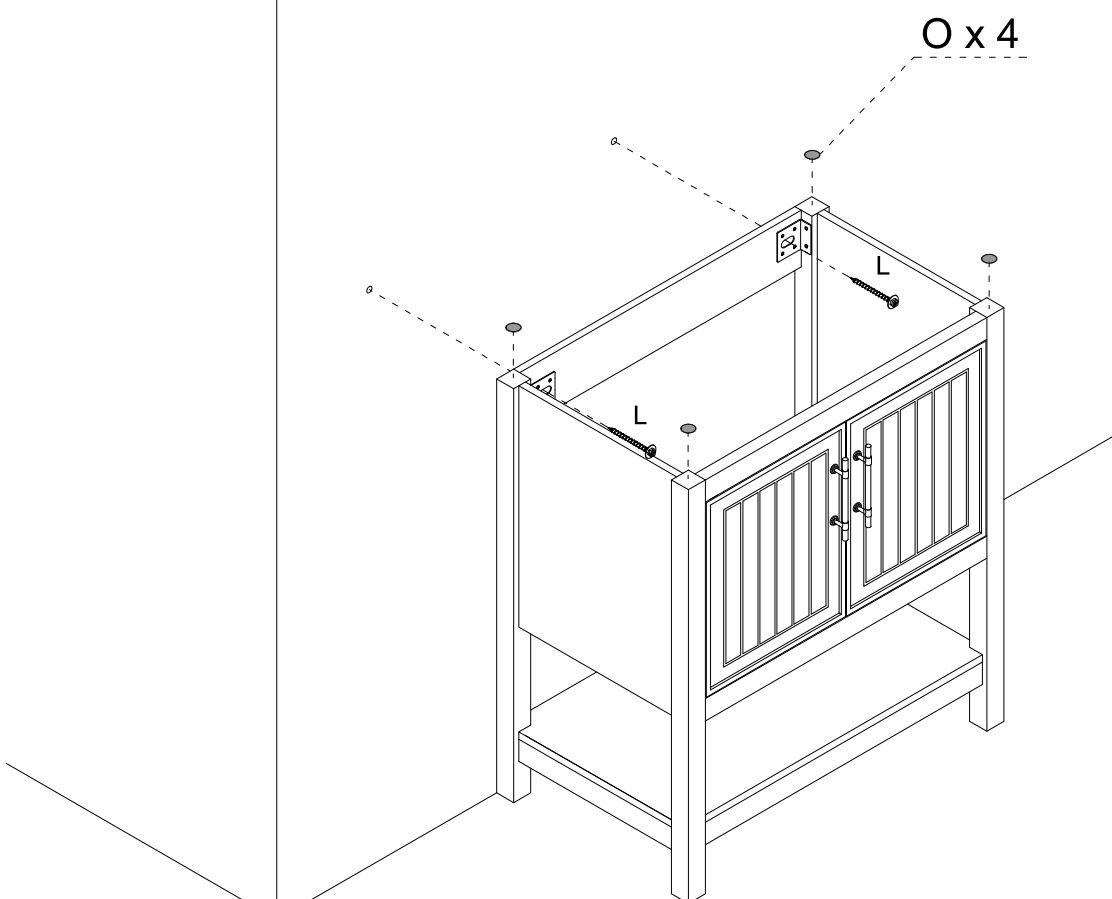

Φ6x60mm
L x 2

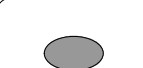

O x 4

Step 16/ étape 16

