

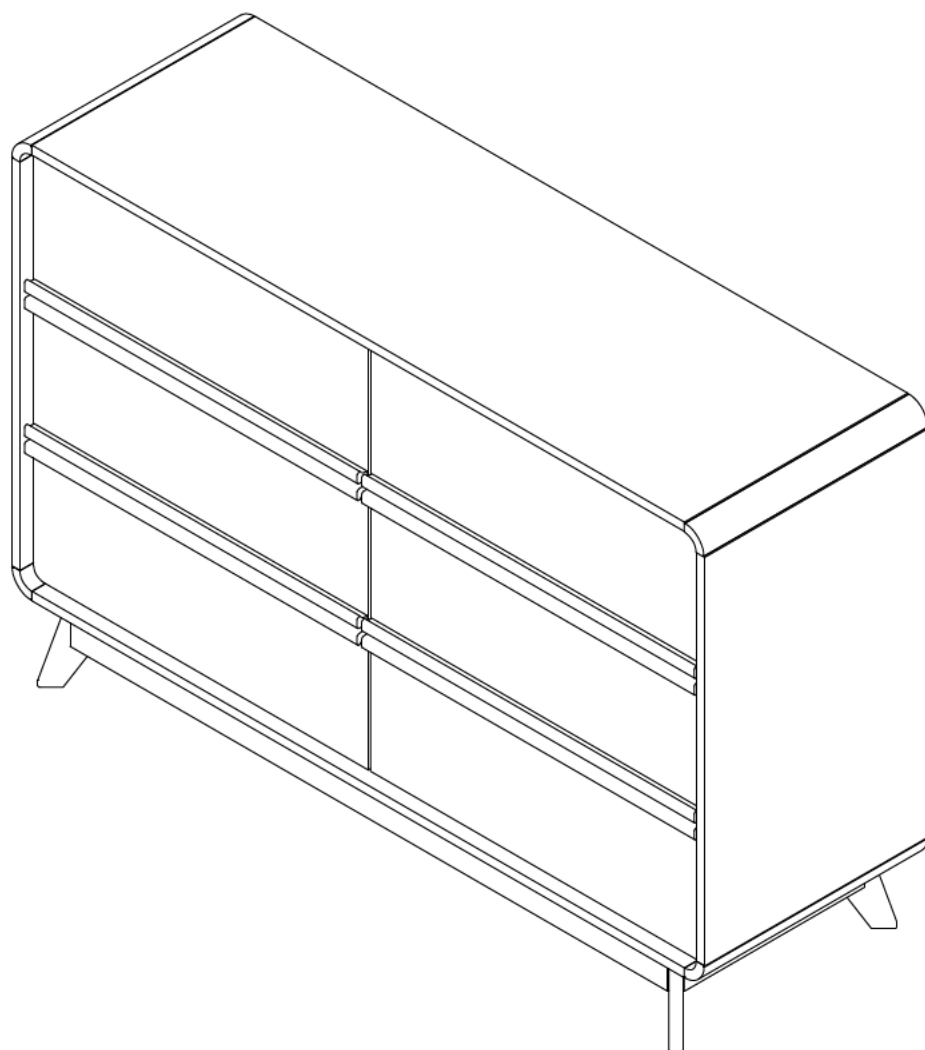

Drawer Chest



Dimensions	No. people	Assembly Time
Width: 124.00cm Depth: 40.00cm Height: 82.60cm		2 Hour (approx.)



Safety and Care Advice

Important - Please read these instructions fully before starting assembly

- Check you have all the components and tools listed on next pages.
- Remove all fittings from the plastic bags and separate them into groups.
- Keep children and animals away from the work area, small parts could choke if swallowed.
- Make sure you have enough space to lay out the parts before starting.
- Do not stand or put weight on the product, this could cause damage.
- Assemble the item as close to its final position (in the same room) as possible.
- Assemble on a soft, level surface to avoid damaging the unit or your floor.
- We do not recommend the use of power drill/drivers for inserting screws, as this could damage the unit. Only use hand screwdrivers.
- Dispose of all packaging carefully and responsibly.
- Warning : Do not over tighten the handle screw that way break the mirror.



Care and Maintenance

- Please clean using cloth with glass cleaner, do not use bleach or abrasive cleaners.
- From time to time check that there are no loose screws on this unit.
- This product should not be discarded with household waste. Take to your local authority waste disposal centre.

- Assemble all parts and bolts loosely during assembly, only once the product is complete should you fully tighten the bolts
- Regularly check and ensure That all bolts and fittings are tightend properly.

WARNING

In order to help prevent overturning-
please follow these instructions

To help prevent product toppling over please follow the below steps:-

Use the anti tip stap or wall fixing method provided (if applicable)

Do not allow children to climb or hang on the furniture

Do not open more than one drawer at a time

Do not place heavy items in the top drawers

Do not place heavy items on top of the furniture, unless the furniture has been designed for this purpose

please note that only the anti tip strap is provided.

You will need to provide wall plugs and screws applicable for your wall type

Important - Please read these instructions fully before starting assembly

Tips before you start:

QUICKFIT

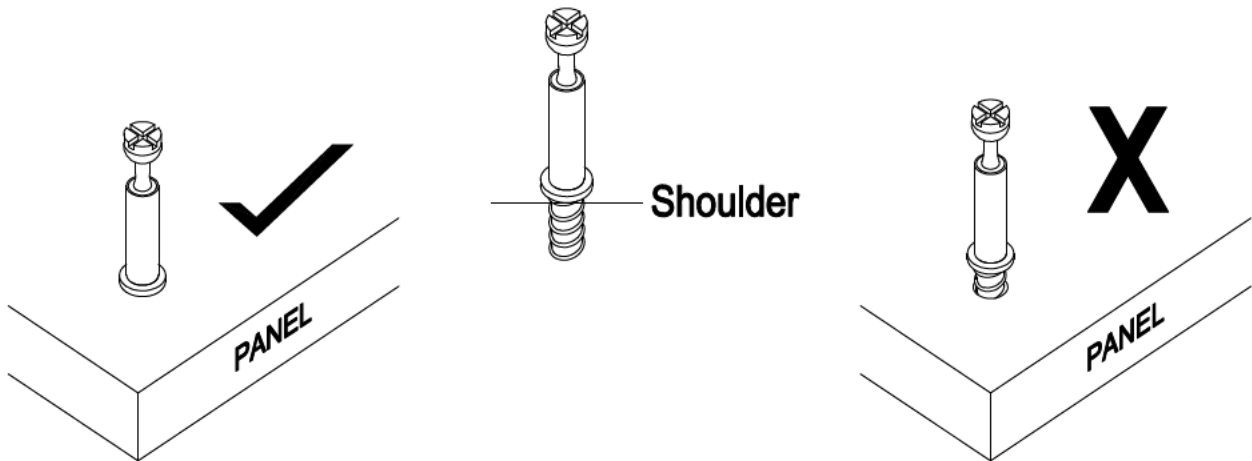

Tighten quickfit until shoulder is flush with panel. Do not overtighten or undertighten.

CAM LOCK

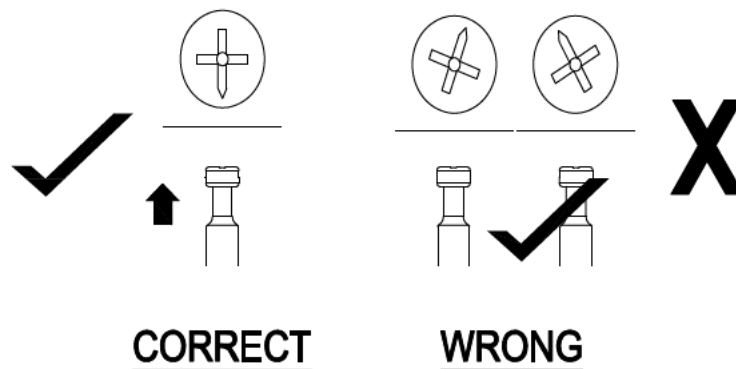

When fitting cam lock, ensure starting position is correct before you insert connecting quickfit.

Quickfit head should be in the centre of the cam lock when the two panels are joined.

Cam lock should be inserted before quickfit.

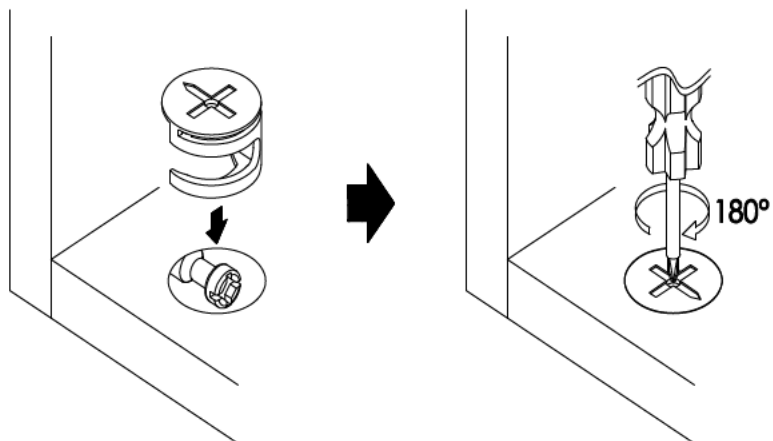

Turn camlock clockwise to tighten.

What You Need

to assemble the product



DO NOT USE



Other Tools You Need

Phillips Head Screwdriver; Hammer

Parts List

- Carton 1:**
- Top Panel (P3)
 - Bottom Panel (P4)
 - 2 x Support Rail Panel (P6)
 - 4 x Leg (P7)
 - 2 x Front / Back Rail Panel (P8)
 - 2 x Side Rail Panel (P9)
 - Drawer Front (P10)
 - Drawer Front (P11)
 - Drawer Front (P12)
 - Drawer Front (P13)
 - Drawer Front (P14)
 - Drawer Front (P15)
 - Left Side Panel (P1)
 - Right Side Panel (P2)
 - Divider Panel (P5)
 - 8 x Handle (P16)
 - 6 x Drawer Left Side panel (P17)
 - 6 x Drawer Right Side Panel (P18)
 - 6 x Drawer Back Panel (P19)
 - 6 x Drawer Support Panel (P20)
 - 6 x Drawer Bottom Panel (P21)
 - 2 x Left Back Panels (P22)
 - 2 x Right Back Panels (P23)

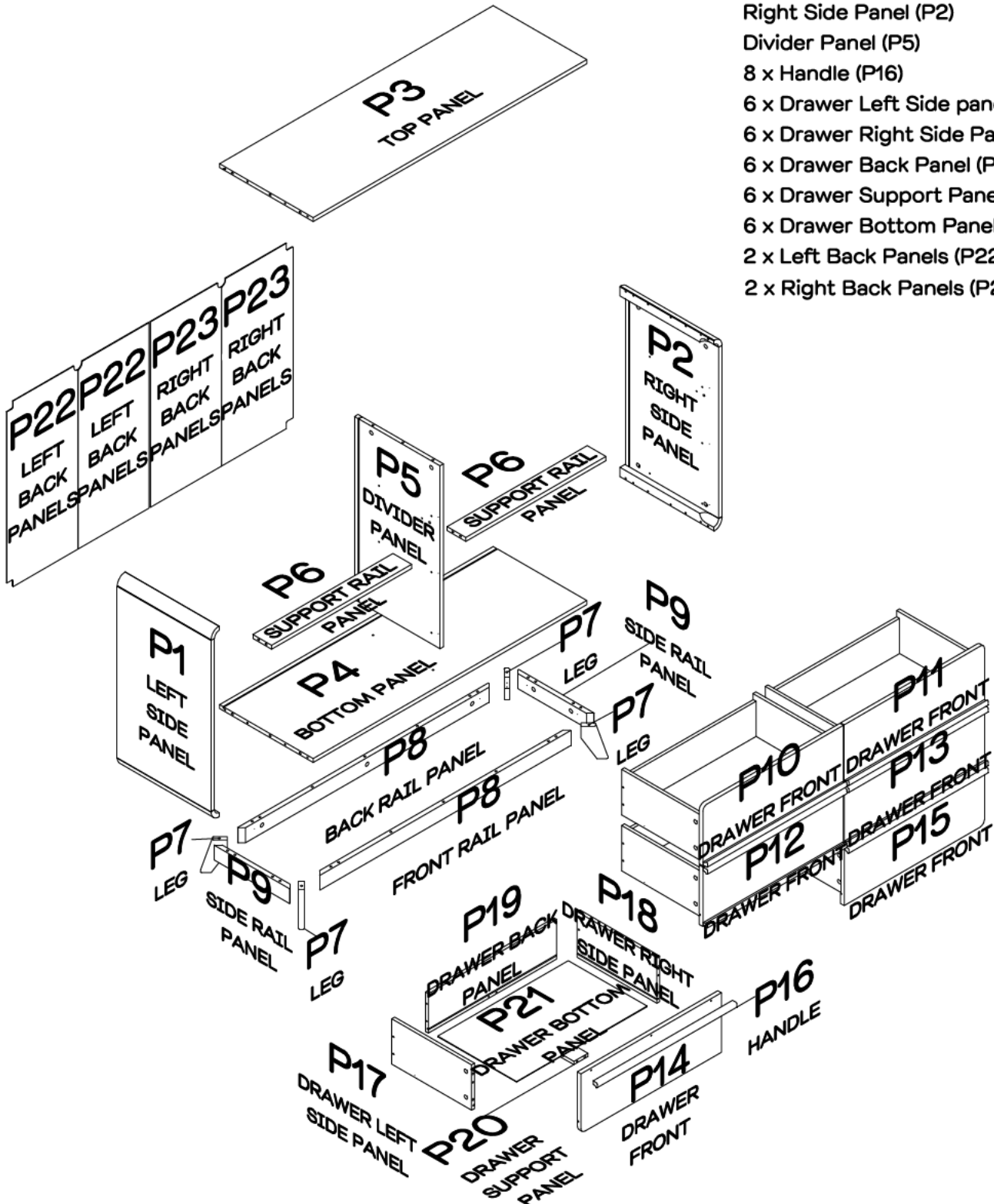

Hardware Pack



12 × Runner
Track Screws
(H1)



36 × Small
Screws
(H2)



22 × Medium
Screws
(H3)

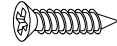

32 × Support
Screws
(H4)



24 × Bolts
(H5)



2 × Screws
With Head
(H6)

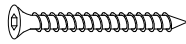

26 × Large
Screws
(H7)



4 × Washers
(H8)



24 × Small
Dowels
(H9)



16 × Large
Dowels
(H10)



21 × Medium
Dowels
(H11)

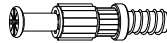

64 × Cam Bolts
(H12)



28 × Large
Cam Nuts
(H13)



36 × Small
Cam Nuts
(H14)

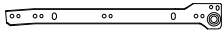

6 × CR Runner
Tracks
(H15)

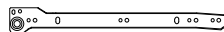

6 × CL Runner
Tracks
(H16)

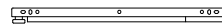

6 × DR
Runners
(H17)

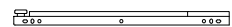

6 × DL
Runners
(H18)



4 × White Die
Cut (H19)

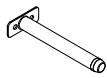

1 × Metal Leg
(H20)



2 × Wall
Bracket
(H21)

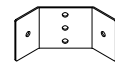

4 × Brackets
(H22)

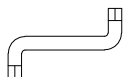

1 × Allen Key
(H23)



12 × Wedges
(H24)

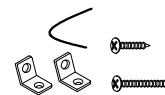

2 × Tipping
Restraint Kit
(H25)

Step 1

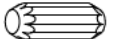
You will need

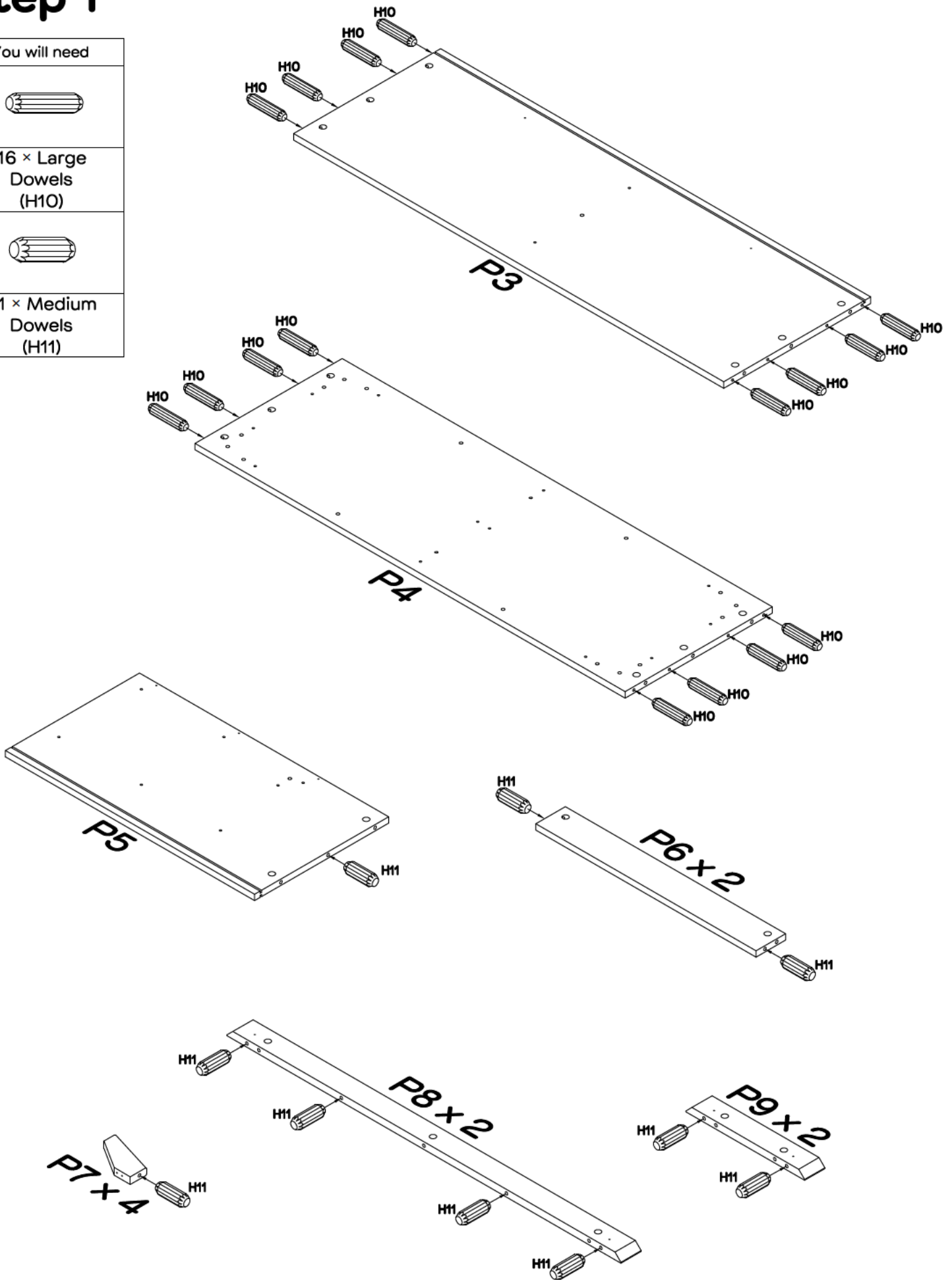
16 × Large Dowels (H10)

21 × Medium Dowels (H11)

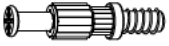

Insert 16 x large dowels (H10) into the top panel (P3) and bottom panel (P4).
Insert 21 x medium dowels (H11) into the divider panel (P5), 2 x support rail panels (P6),
4 x legs (P7), 2 x front / back rail panels (P8) and 2 x side rail panels (P9).

Step 2

You will need



28 × Cam Bolts
(H12)



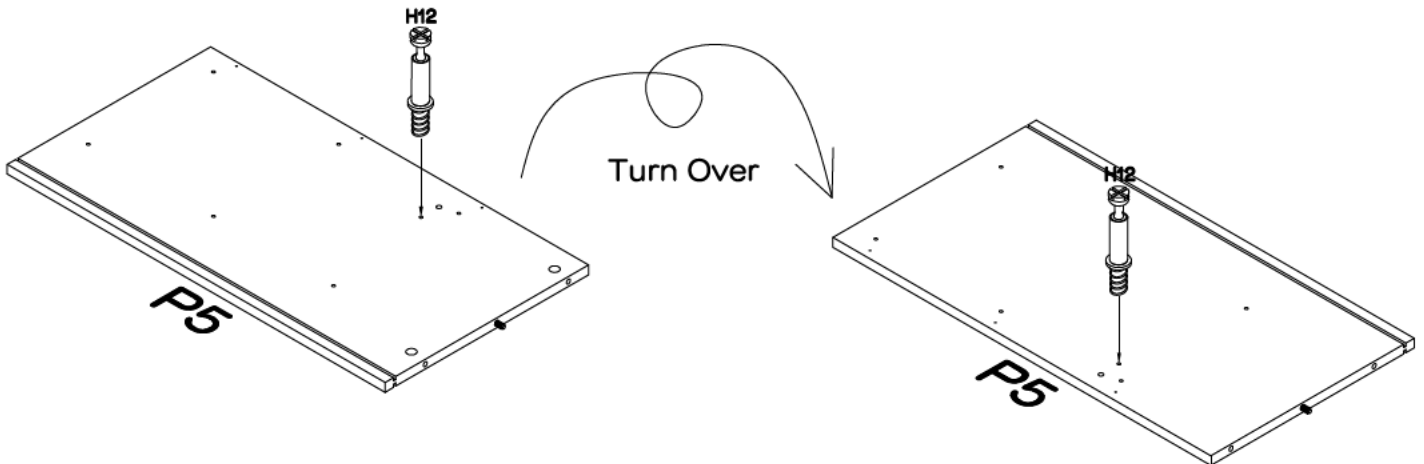
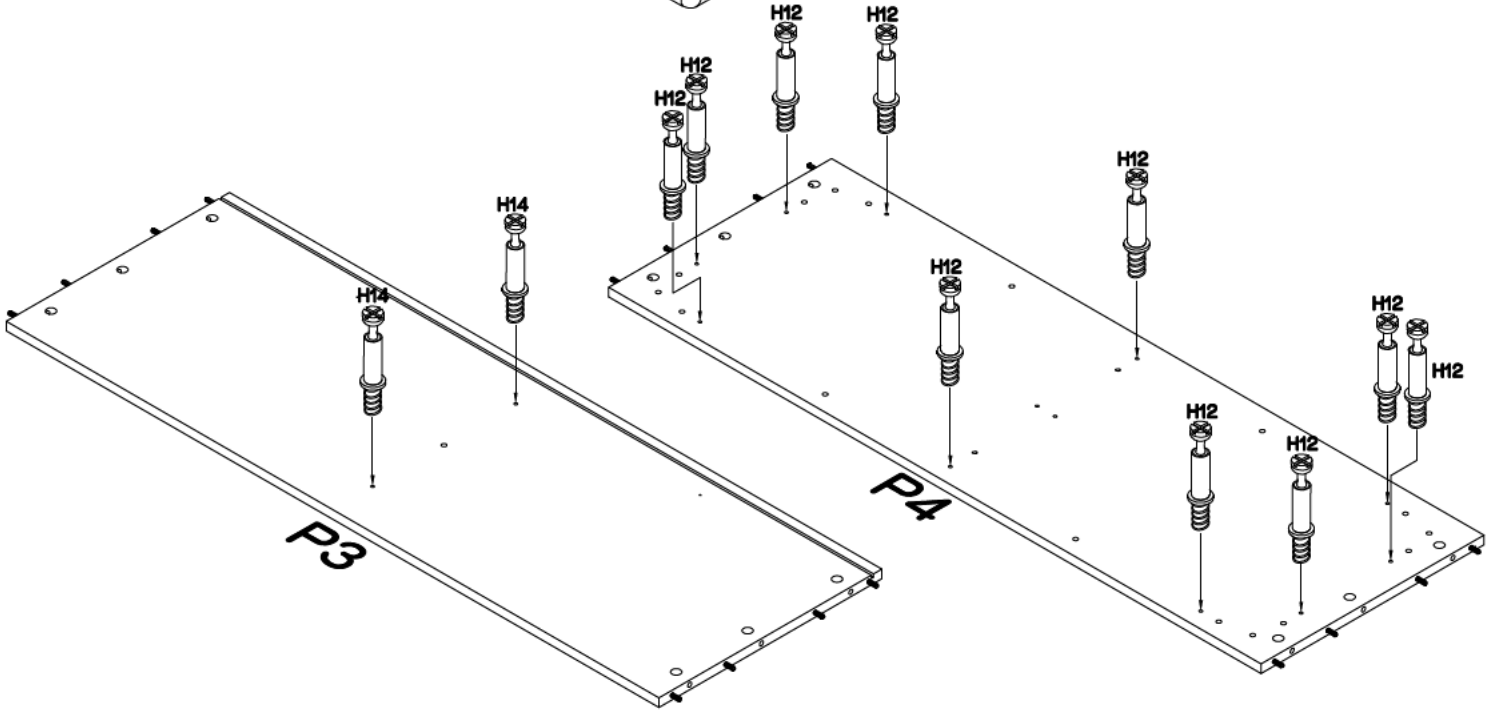
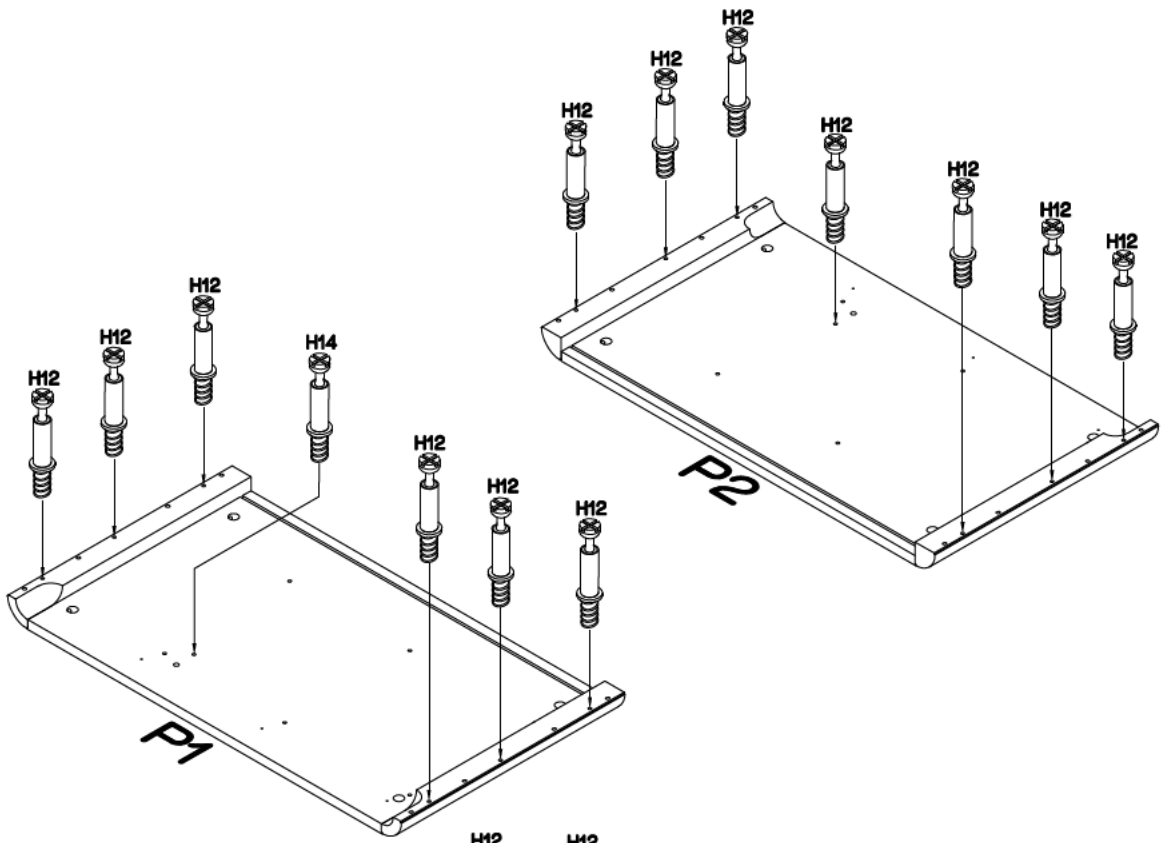

Phillips Head
Screwdriver



Secure 28 x cam bolts (H12) into the left side panel (P1), right side panel (P2), top panel (P3), bottom panel (P4) and divider panel (P5), tightening with a phillips head screwdriver.

Step 3

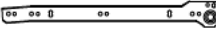
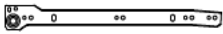
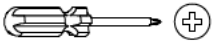

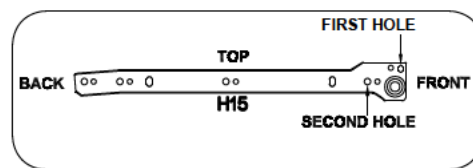
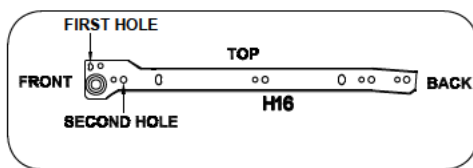
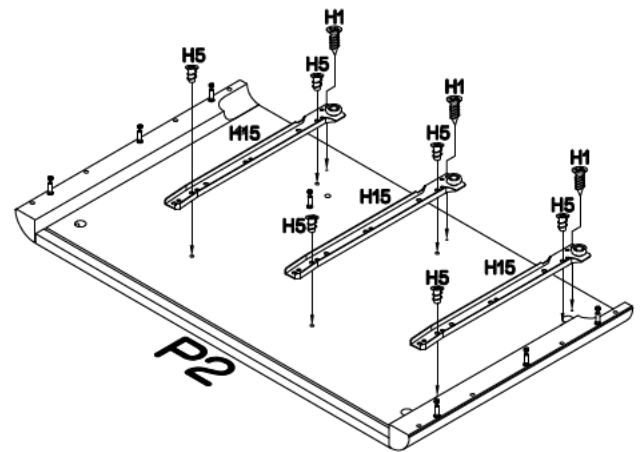
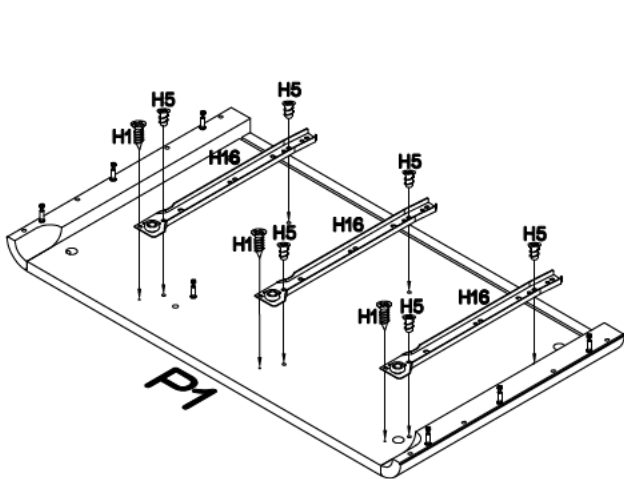
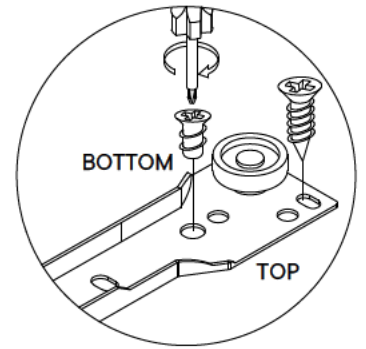
You will need	
	
6 × Runner Track Screws (H1)	12 × Bolts (H5)
	
3 × CR Runner Tracks (H15)	3 × CL Runner Tracks (H16)
	
Phillips Head Screwdriver	



PLEASE ENSURE TO FIX THE SCREWS AS PER POINTED HOLES INSTRUCTION TO AVOID DISTORTION OF OVERALL LOOK OF PRODUCTS.

Attach 3 x CL runner tracks (H16) to left side panel (P1), 3 x CR runner tracks (H15) to right side panel (P2), use 12 x bolts (H5) and 6 x runner track screws (H1), tightening with the phillips head screwdriver.

Step 4

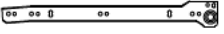
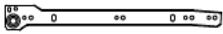
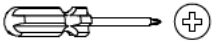
You will need	
	
6 × Runner Track Screws (H1)	12 × Bolts (H5)
	
3 × CR Runner Tracks (H15)	3 × CL Runner Tracks (H16)
	
Phillips Head Screwdriver	

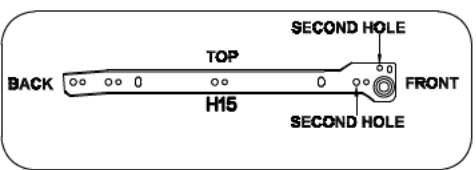
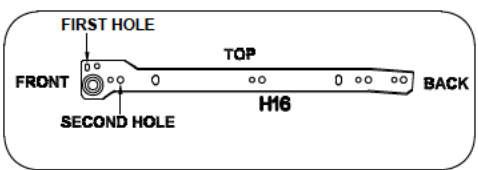
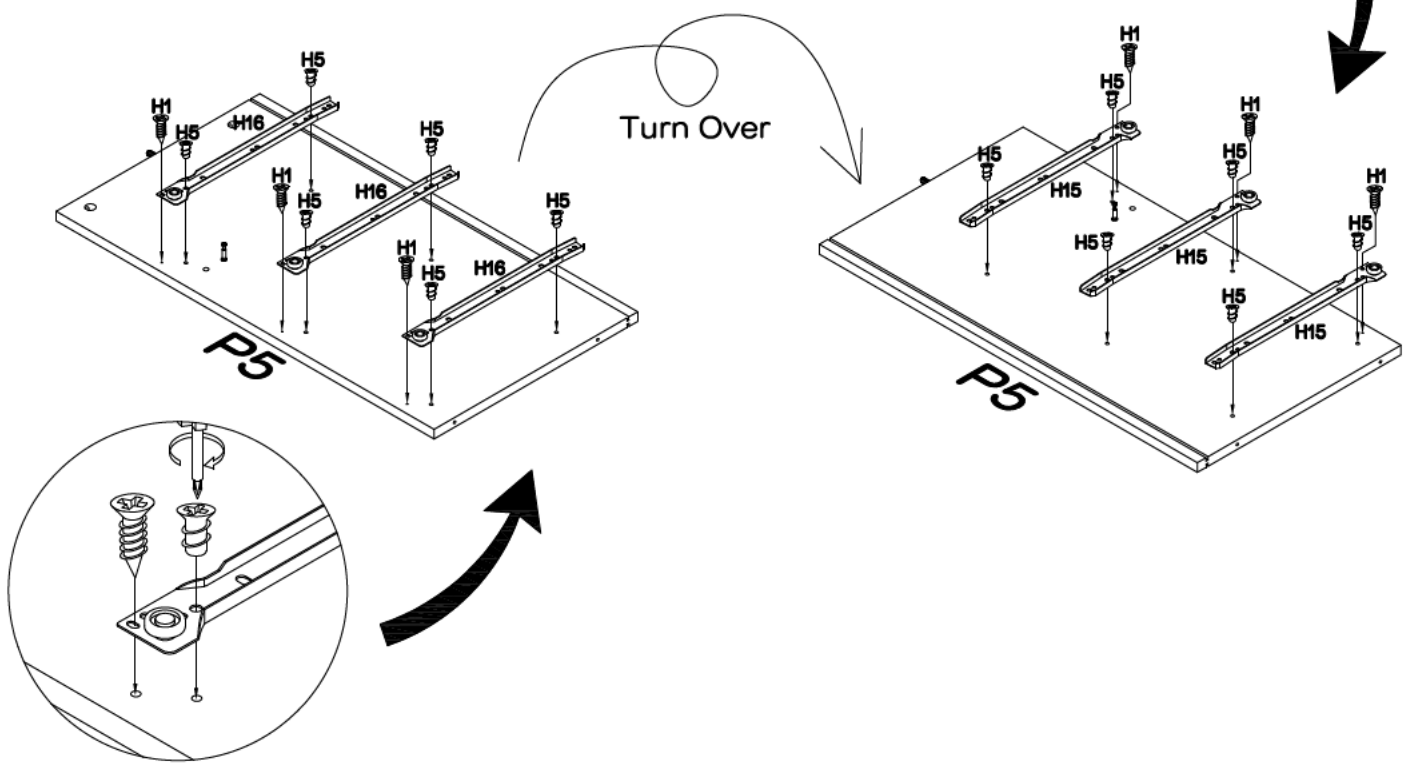
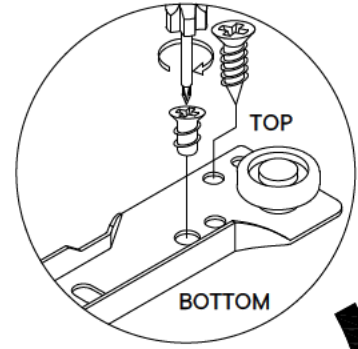

PLEASE ENSURE TO FIX THE SCREWS AS PER POINTED HOLES INSTRUCTION TO AVOID DISTORTION OF OVERALL LOOK OF PRODUCTS.

Attach 3 x CL runner tracks (H16) to divider panel (P5), 3 x CR runner tracks (H15) to divider panel (P5), use 12 x bolts (H5) and 6 x runner track screws (H1), tightening with the phillips head screwdriver.

Step 5

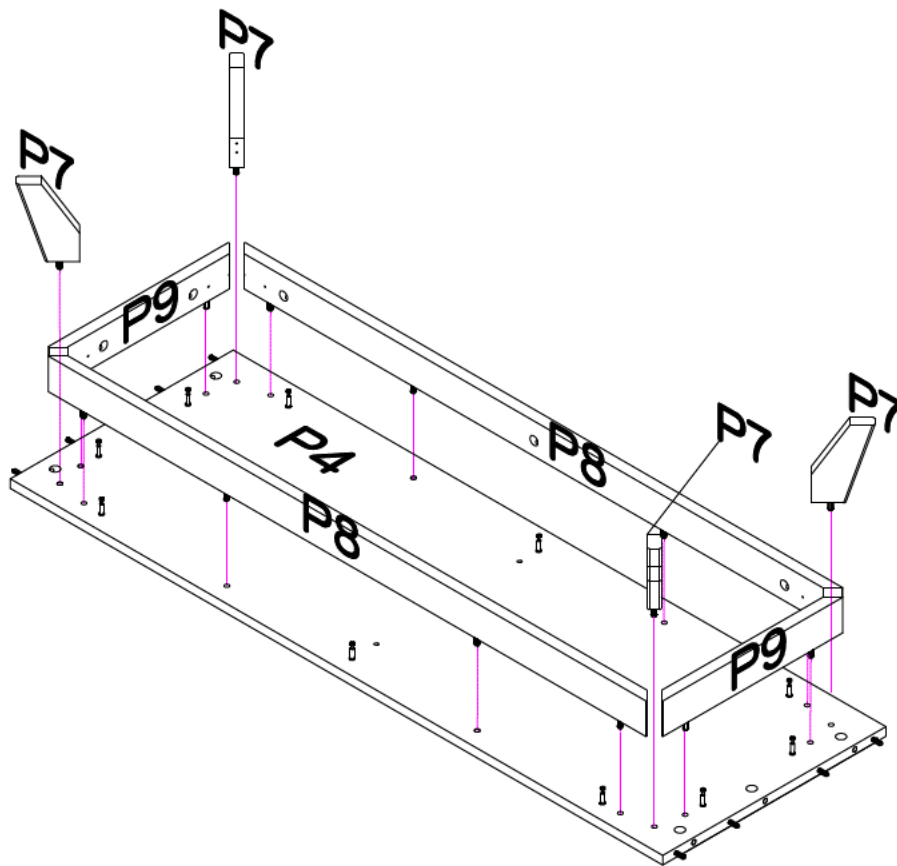

Attach the 4 x legs (P7), 2 x front / back rail panels (P8) and the 2 x side rail panels (P9) to the bottom panel (P4) as shown.

Step 6

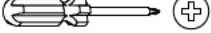
You will need

10 × Large Cam Nuts (H13)

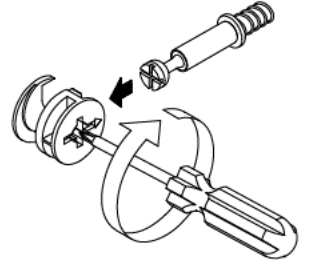
Phillips Head Screwdriver

This is how a cam nut works...

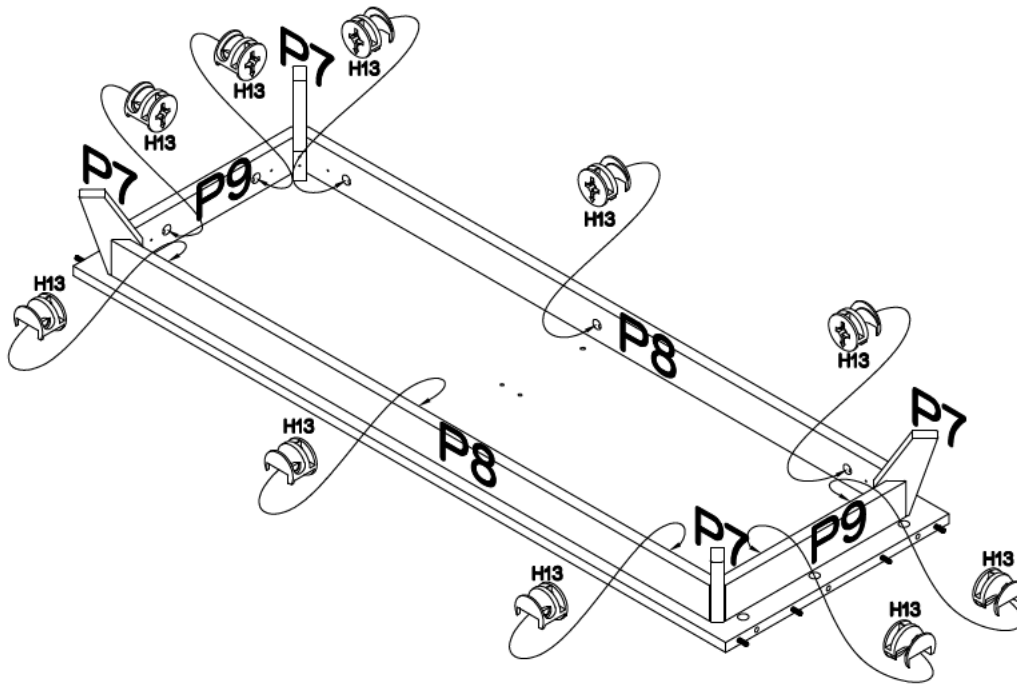

The head of the cam bolt goes into the open mouth of the cam nut. You then turn the cam nut so it tightens over the bolt.





Insert 10 x large cam nuts (H13) into the 2 x front / back rail panels (P8) and 2 x side rail panels (P9).

Make sure the arrows point towards incoming cam bolts.

Attach the 2 x front / back rail panels (P8) and the 2 x side rail panels (P9) to the bottom panel (P4) and secure by tightening large cam nuts (H13) using a phillips head screwdriver.

Step 7

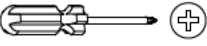
You will need	
	
8 x Medium Screws (H3)	8 x Support Screws (H4)
	
4 x Brackets (H22)	Phillips Head Screwdriver

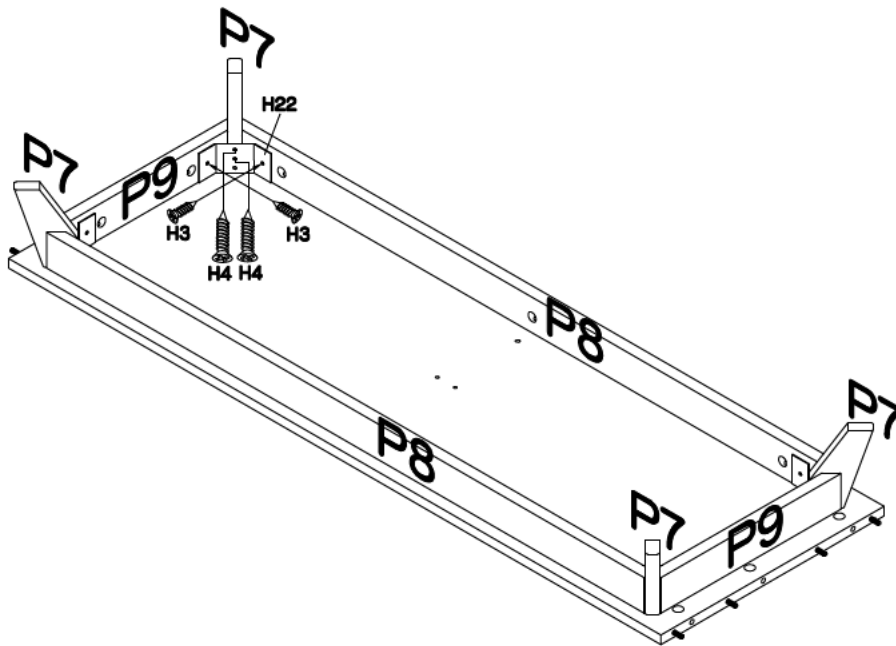
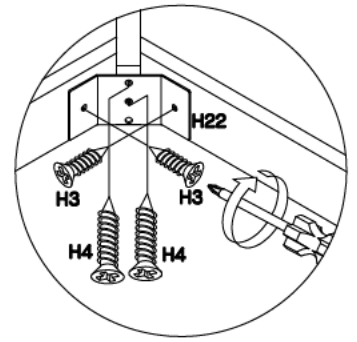

Attach 4 x brackets (H22) into the 4 x legs (P7), 2 x front / back rail panels (P8) and the 2 x side rail panels (P9) using 8 x medium screws (H3) and 8 x support screws (H4), tightening with the phillips head screwdriver.

Step 8

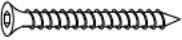
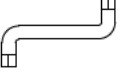
You will need

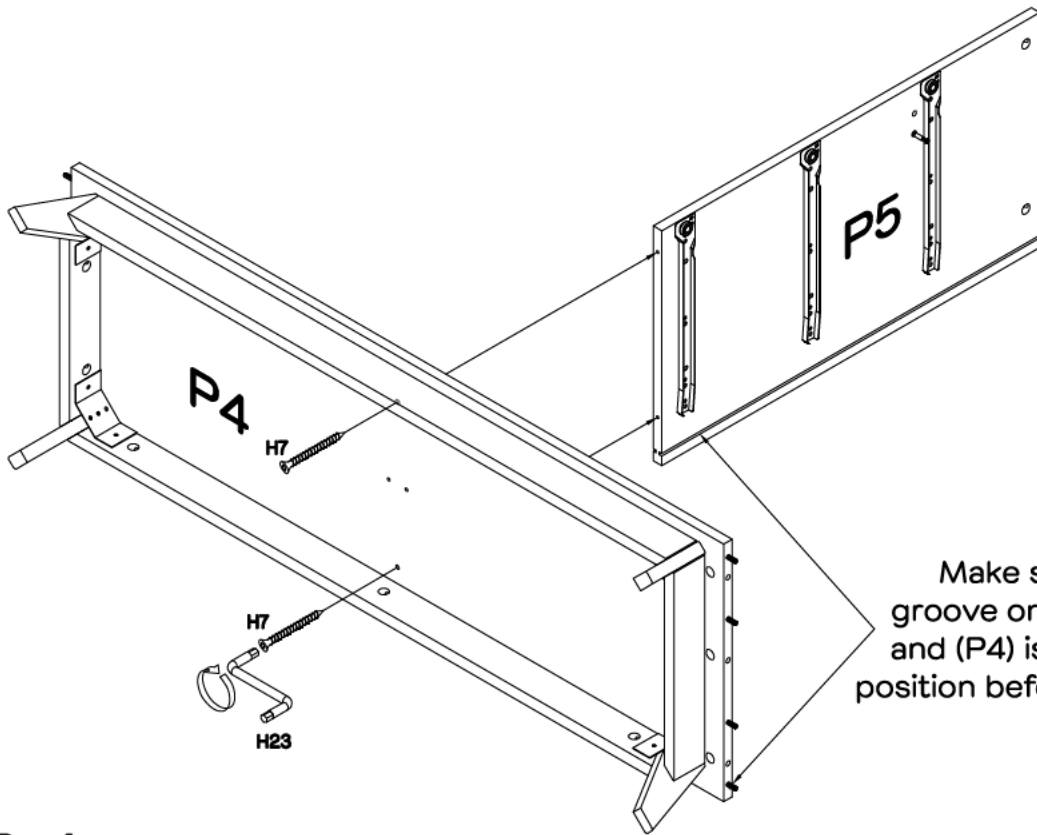
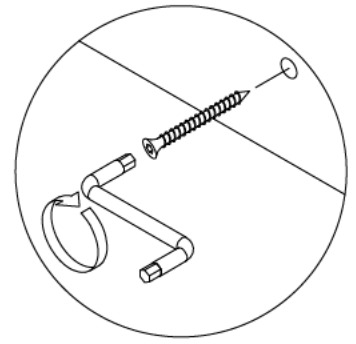
2 × Large Screws (H7)

1 × Allen Key (H23)

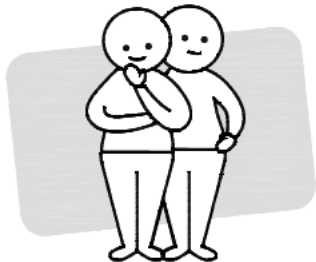

Make sure the groove on panel (P5) and (P4) is in correct position before screwing.



Two People



Required

Attach the divider panel (P5) to the bottom panel (P4).
Secure the divider panel (P5) to the bottom panel (P4) with 2 x large screws (H7),
tightening with the allen key (H23).

Step 9

You will need

2 × Large Cam Nuts (H13)

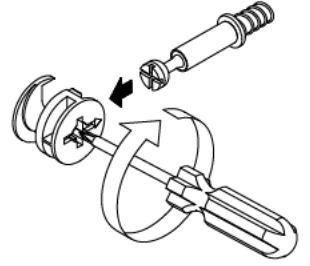
Phillips Head Screwdriver

This is how a cam nut works...

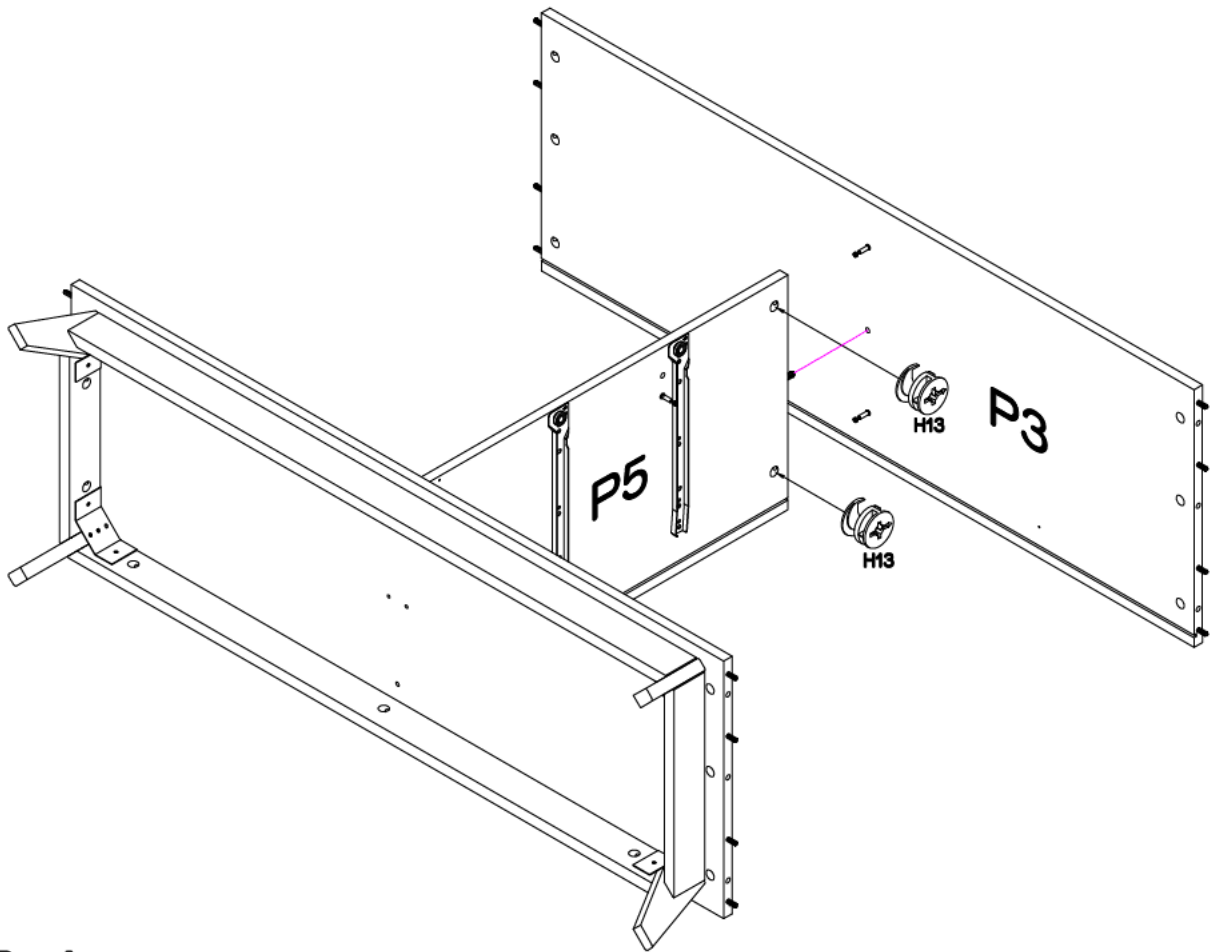

The head of the cam bolt goes into the open mouth of the cam nut. You then turn the cam nut so it tightens over the bolt.



Two People

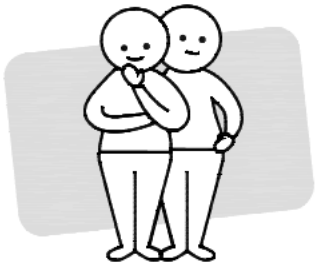

Required

Insert 2 x large cam nuts (H13) into the divider panel (P5).

Rotate the cam nuts so the arrows point towards incoming cam bolts.

Attach the top panel (P3) to the divider panel (P5) and secure by tightening large cam nuts (H13) using a phillips head screwdriver.

Step 10

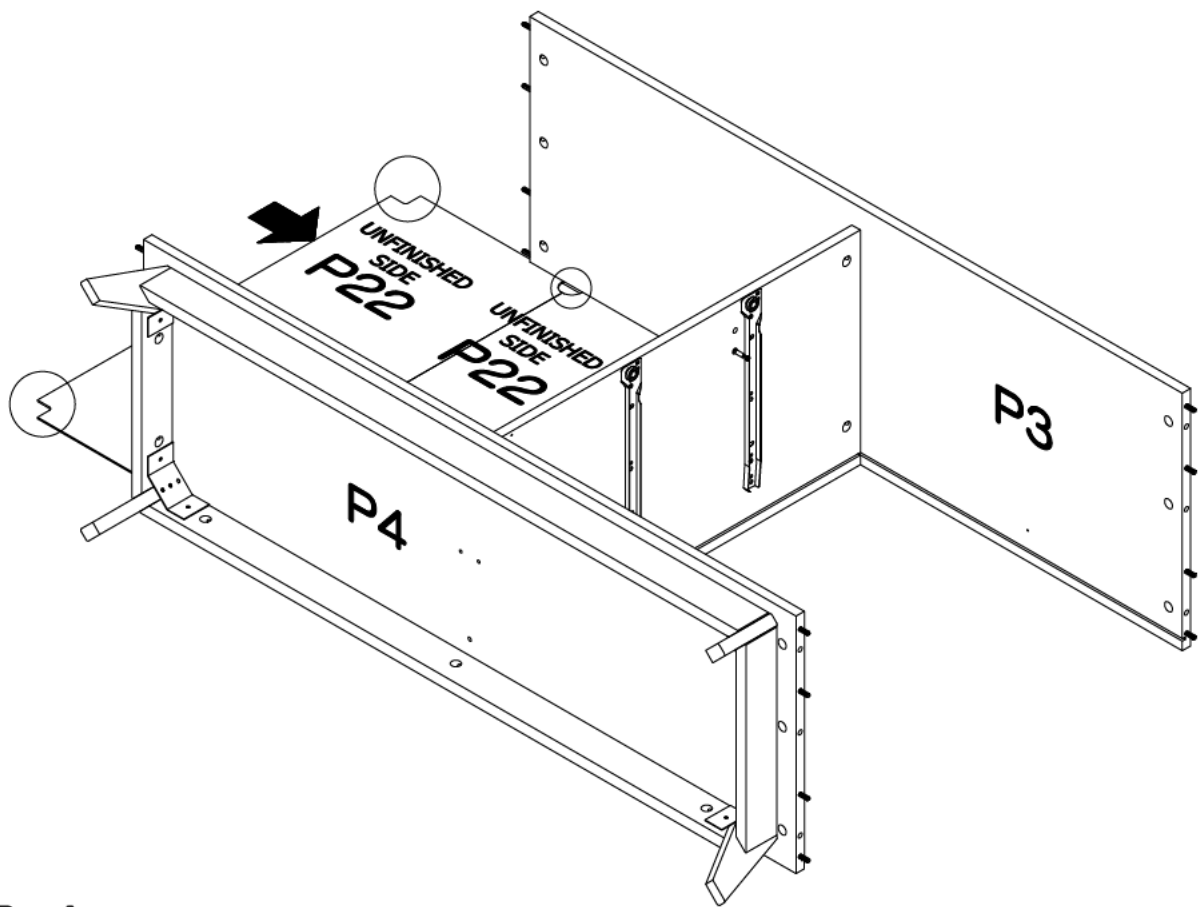

Two People

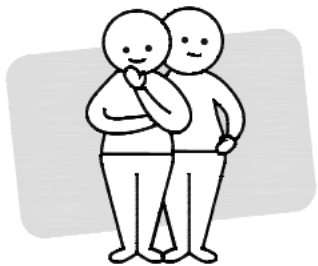

Required



Slide in 2 x left back panels (P22) into the grooves on the top panel (P3) and bottom panel (P4). Note the positioning of the back panel.

Step 11

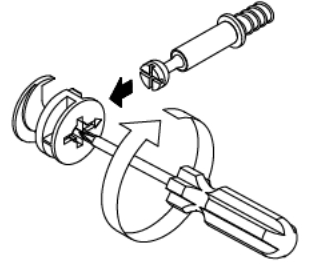
This is how a cam nut works...



The head of the cam bolt goes into the open mouth of the cam nut. You then turn the cam nut so it tightens over the bolt.

You will need

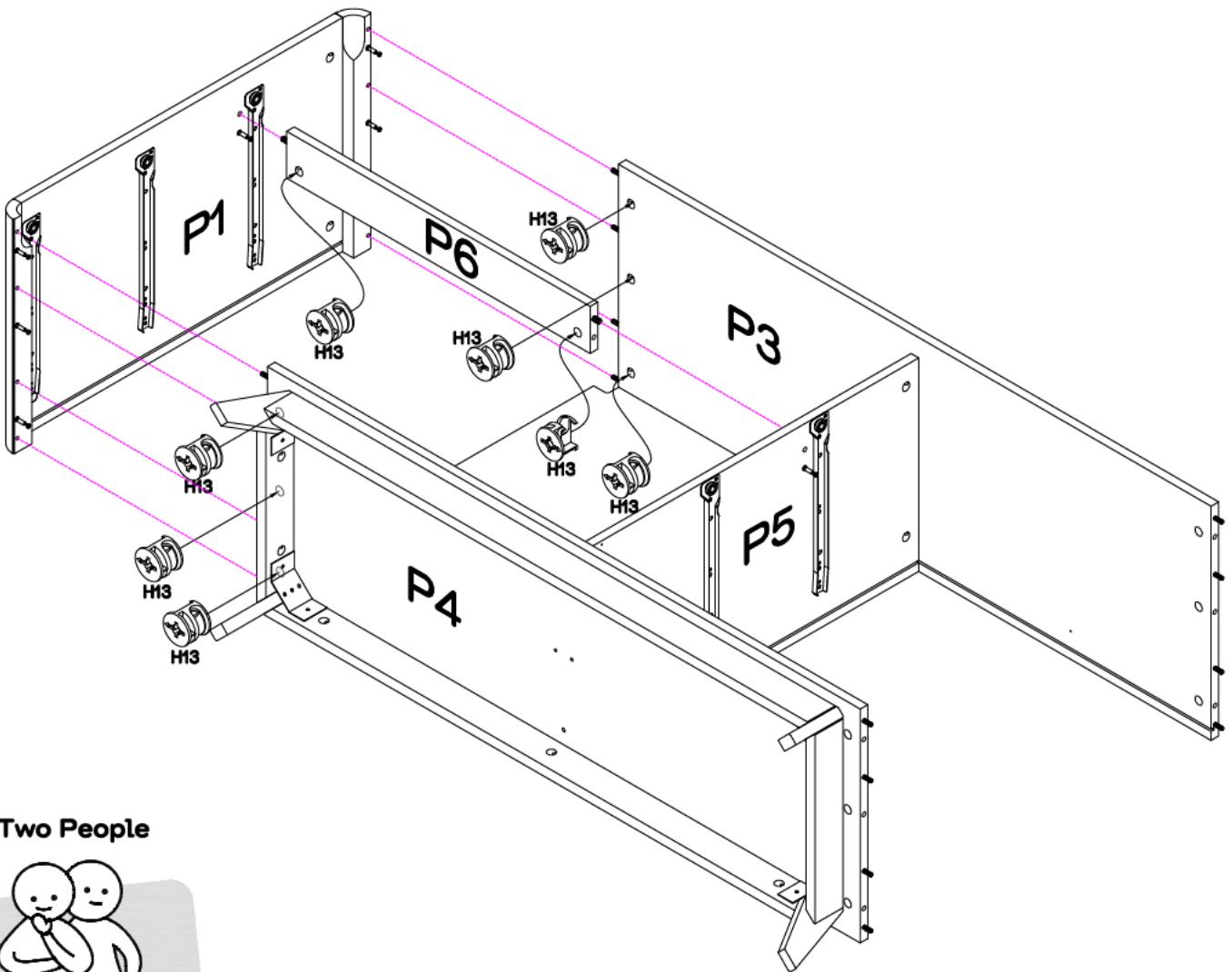
8 × Large Cam Nuts (H13)

Phillips Head Screwdriver

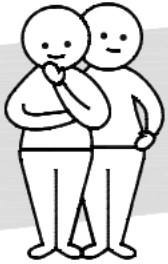

Two People



Required

Insert 8 x large cam nuts (H13) into the top panel (P3), bottom panel (P4), and support rail panel (P6).

Rotate the cam nuts so the arrows point towards incoming cam bolts.

Attach the left side panel (P1) and rail panel (P6) to the top panel (P3) and bottom panel (P4) and divider panel (P5) secure by tightening large cam nuts (H13) using a phillips head screwdriver.

Step 12

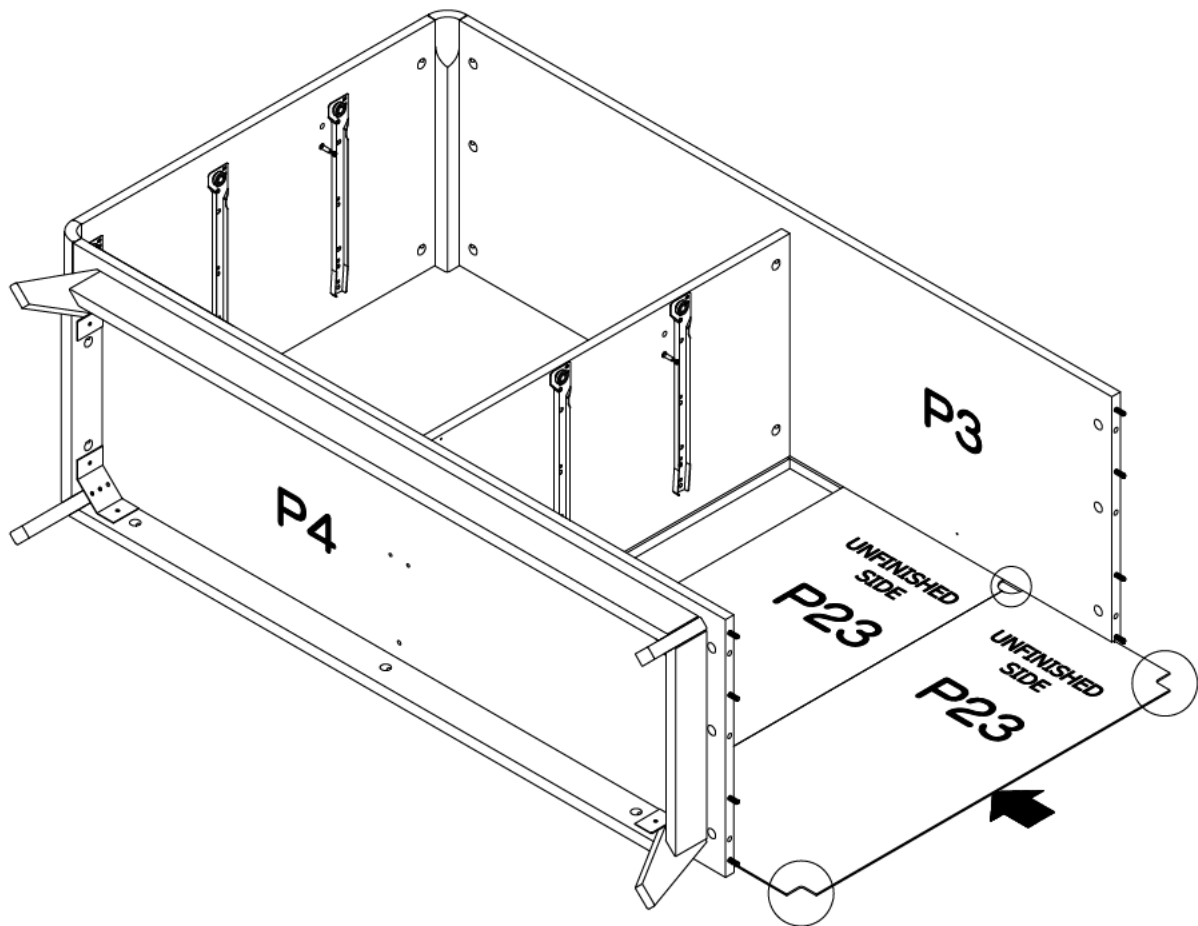

Two People

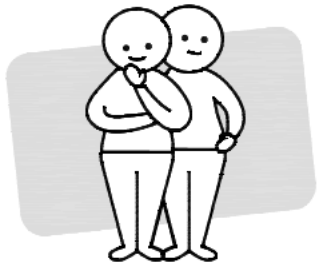

Required



Slide in 2 x right back panels (P23) into the grooves on the top panel (P3) and bottom panel (P4). Note the positioning of the back panel.

Step 13

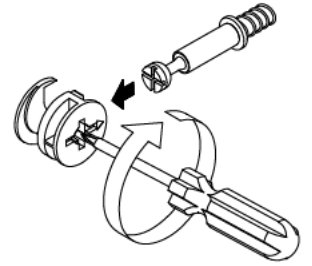
This is how a cam nut works...



The head of the cam bolt goes into the open mouth of the cam nut. You then turn the cam nut so it tightens over the bolt.

You will need

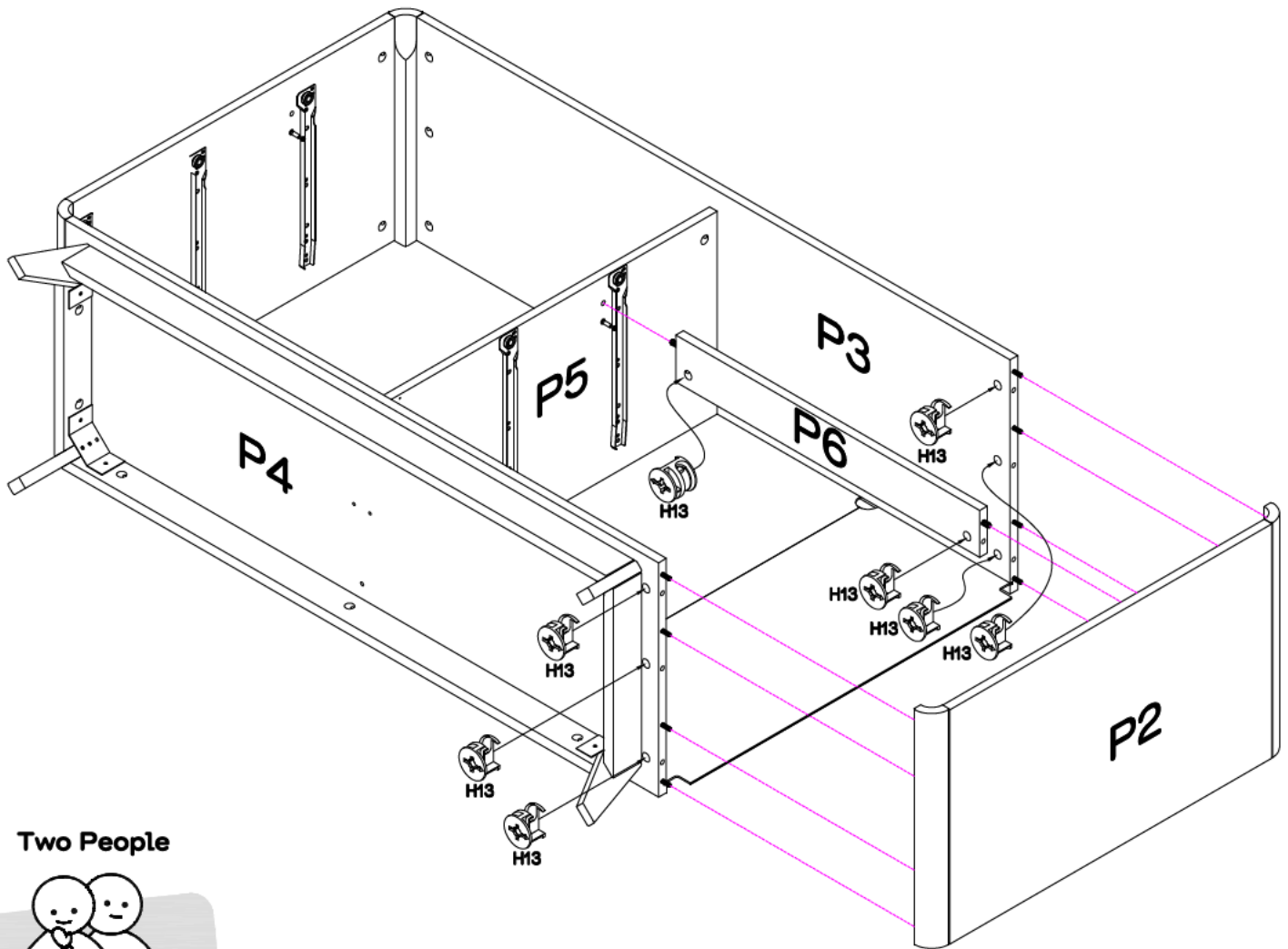
8 × Large Cam Nuts (H13)

Phillips Head Screwdriver



Two People







Required

Insert 8 x large cam nuts (H13) into the top panel (P3), bottom panel (P4) and support rail panel (P6).

Rotate the cam nuts so the arrows point towards incoming cam bolts.

Attach the right side panel (P2) and rail panel (P6) to the top panel (P3), bottom panel (P4) and divider panel (P5) secure by tightening large cam nuts (H13) using a phillips head screwdriver.

Step 14

You will need	
	
2 x Screws with Head (H6)	4 x White Die Cut (H19)
	
1 x Metal Leg (H20)	Phillips Head Screwdriver

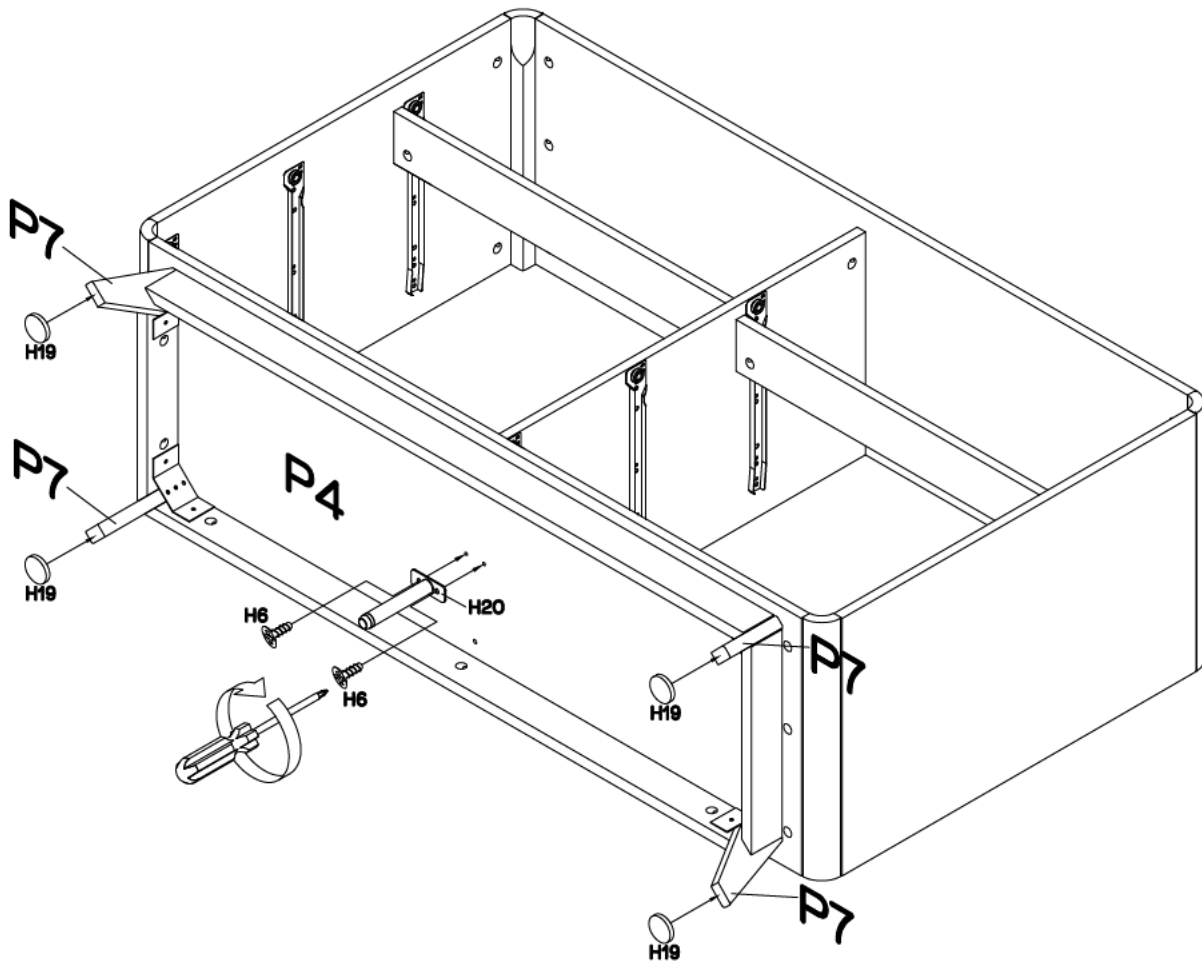

Attach the 1 x metal leg (H20) using 2 x screws with head (H6) to the bottom panel (P4) using a phillips head screwdriver and add 4 x white die cut (H19) into leg (P7).

Step 15

You will need



24 × Small
Dowels
(H9)

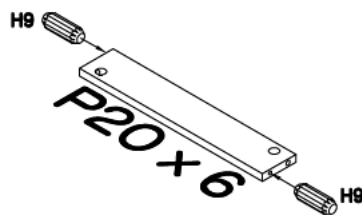
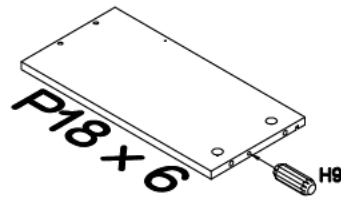
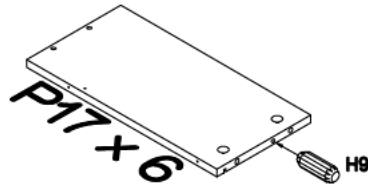

Insert 24 x small dowels (H9) into 6 x drawer left side panels (P17),
6 x drawer right side panels (P18) and 6 x drawer support panels (P20).

Step 16

You will need

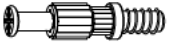

36 × Cam Bolts
(H12)



Phillips Head
Screwdriver

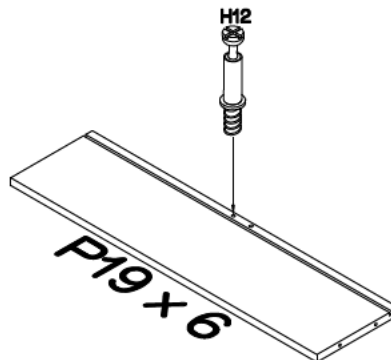
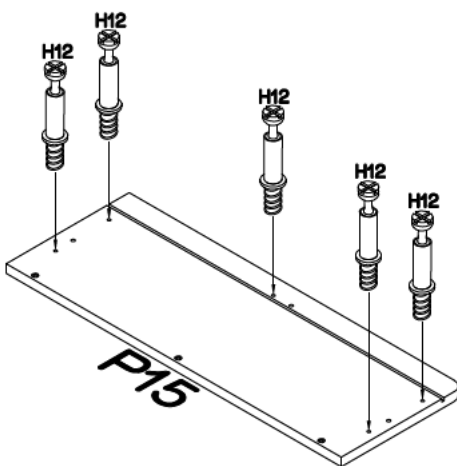
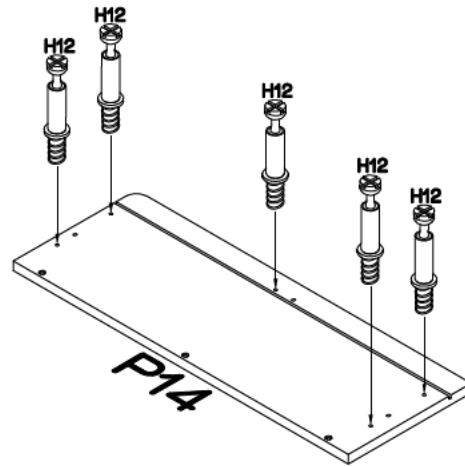
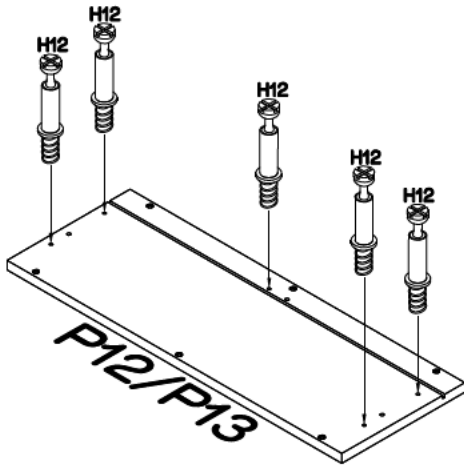
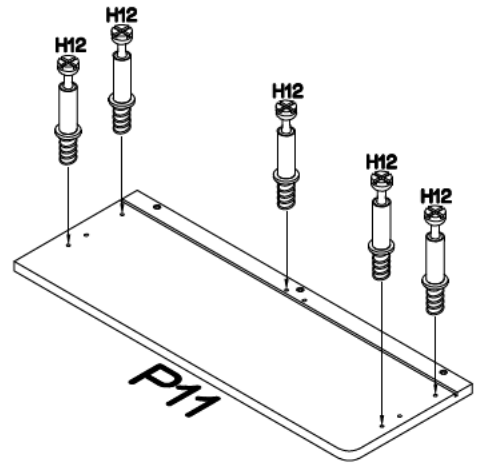
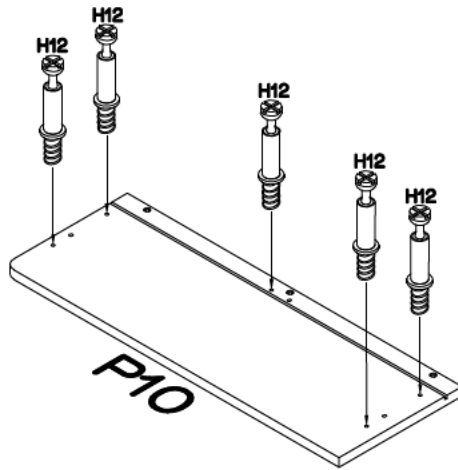

Secure 36 x cam bolts (H12) into the drawer front panels (P10, P11, P12, P13, P14 & P15) and 6 x drawer back panel (P19), tightening with a phillips head screwdriver.

Step 17

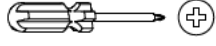
You will need

30 × Small Cam Nuts (H14)

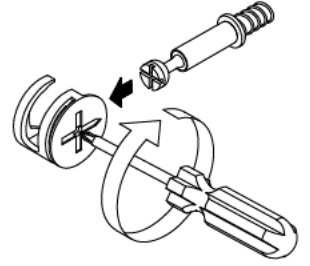
Phillips Head Screwdriver

This is how a cam nut works...

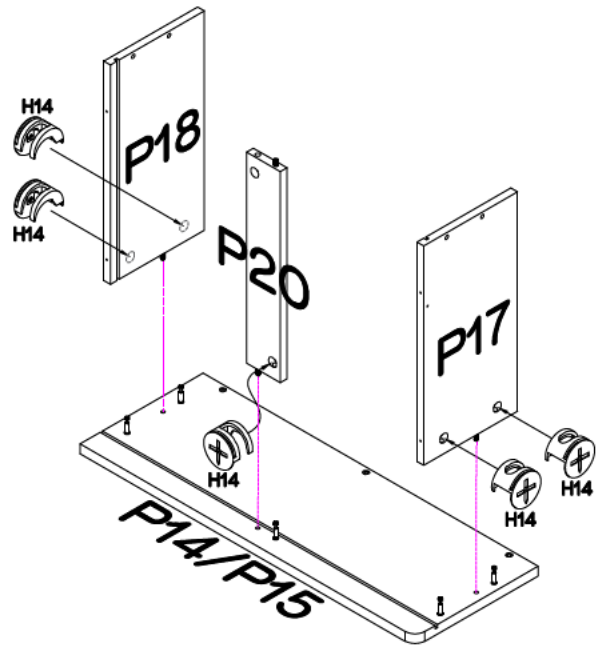
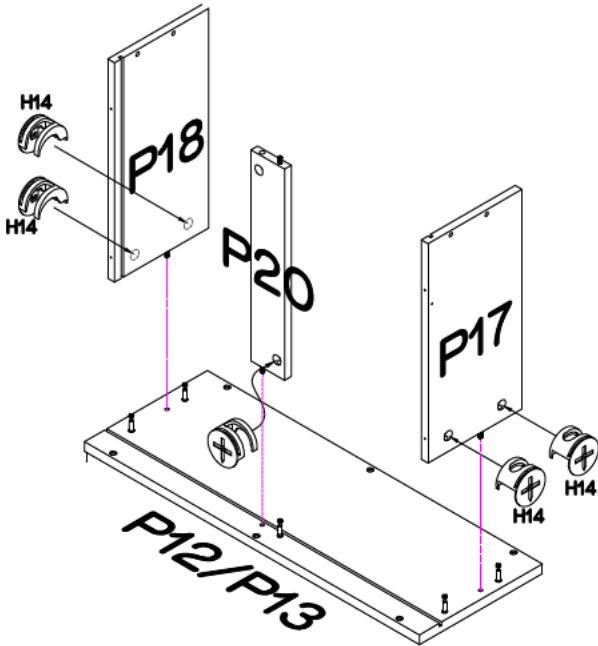
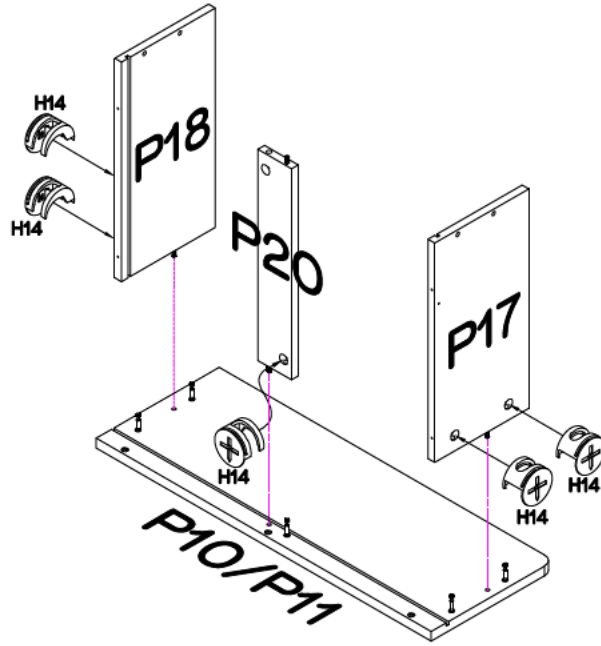

The head of the cam bolt goes into the open mouth of the cam nut. You then turn the cam nut so it tightens over the bolt.



Insert 30 x small cam nuts (H14) into drawer left & right side panels (P17 & P18) and drawer support panel (P20).

Rotate the cam nuts so the arrows point towards incoming cam bolts.

Attach the drawer left & right side panels (P17 & P18) and drawer support panel (P20)

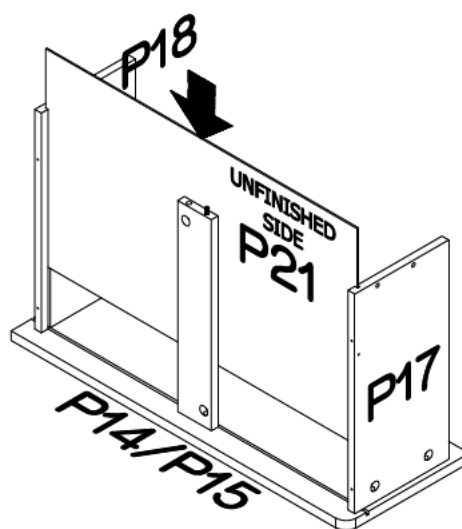
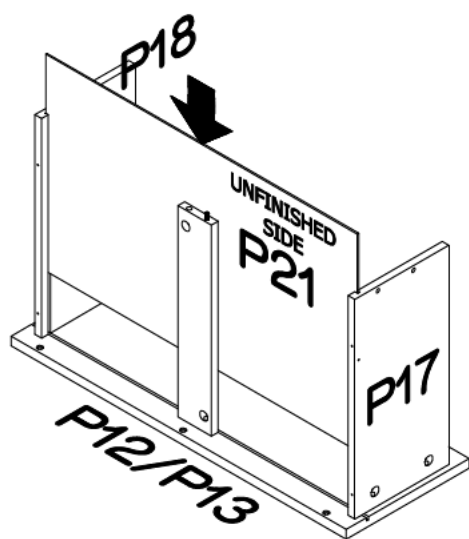
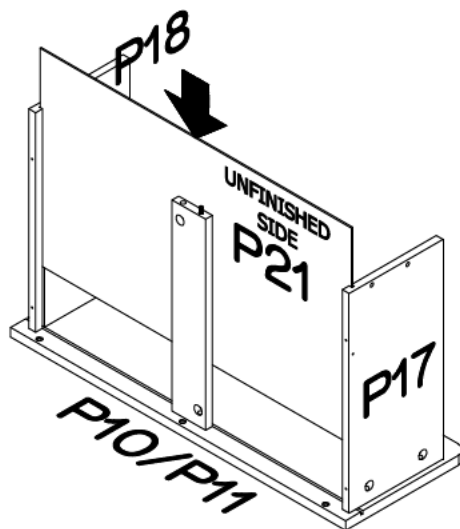

to the drawer front (P10, P11, P12, P13, P14, P15), secure by tightening the small cam nuts (H14) with a philips head screwdriver.

Step 18

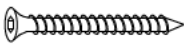

Slide in drawer bottom panel (P21) into the grooves on the drawer left side panel (P17) and drawer right side panel (P18). Repeat this process for the other drawers.

Step 19

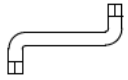
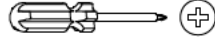
You will need	
	
24 × Large Screws (H7)	6 × Small Cam Nuts (H14)
	
1 × Allen Key (H23)	Phillips Head Screwdriver

This is how a cam nut works...

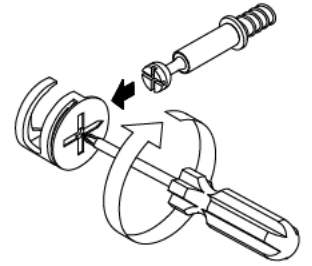

The head of the cam bolt goes into the open mouth of the cam nut. You then turn the cam nut so it tightens over the bolt.

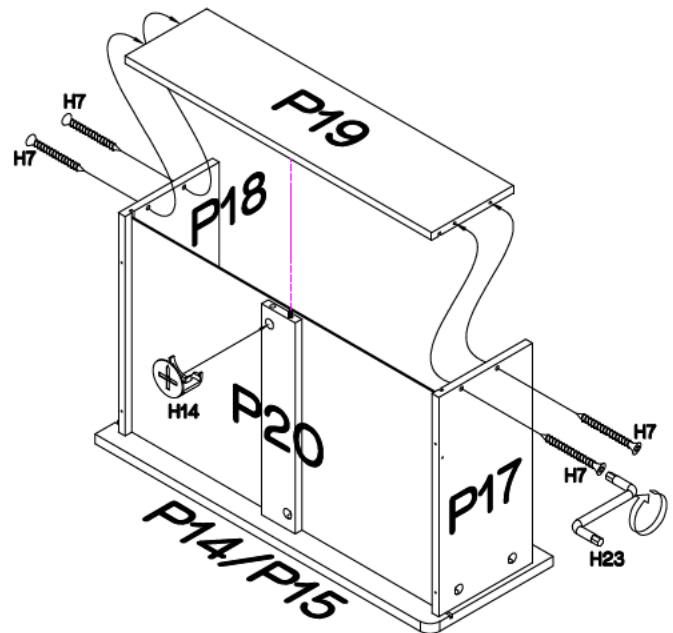
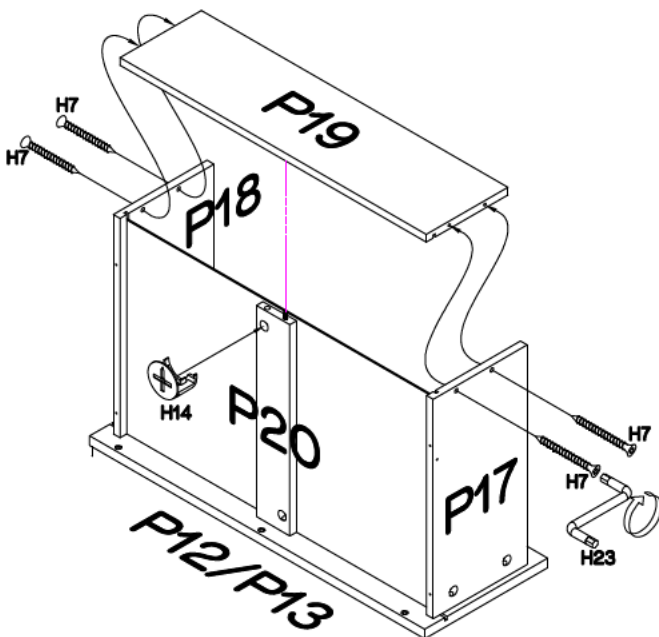
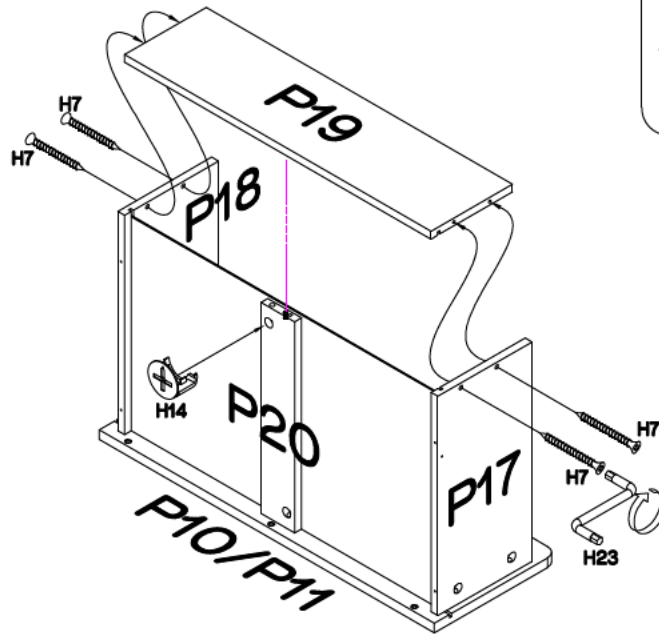

Attach the drawer back panel (P19) to the drawer left side panel (P17) and drawer right side panel (P18) with 4 x large screws (H7), tightening with the allen key (H23).

Insert 6 x small cam nuts (H14) into the drawer support panel (P20).

Rotate the cam nuts so the arrows point towards incoming cam bolts and secure by tightening small cam nuts (H14) using a phillips head screwdriver. Repeat this process for the other drawers.

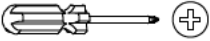

Step 20

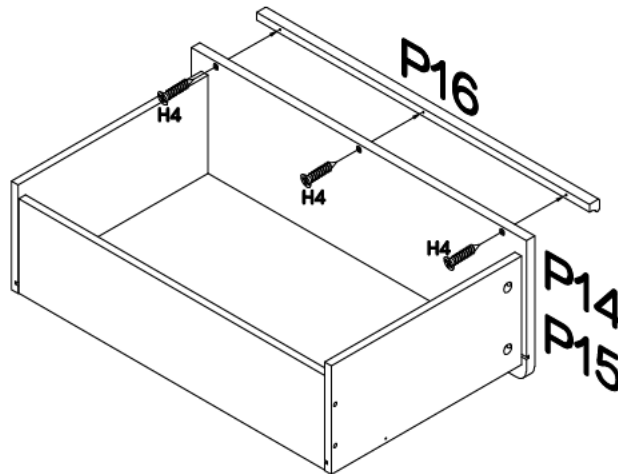
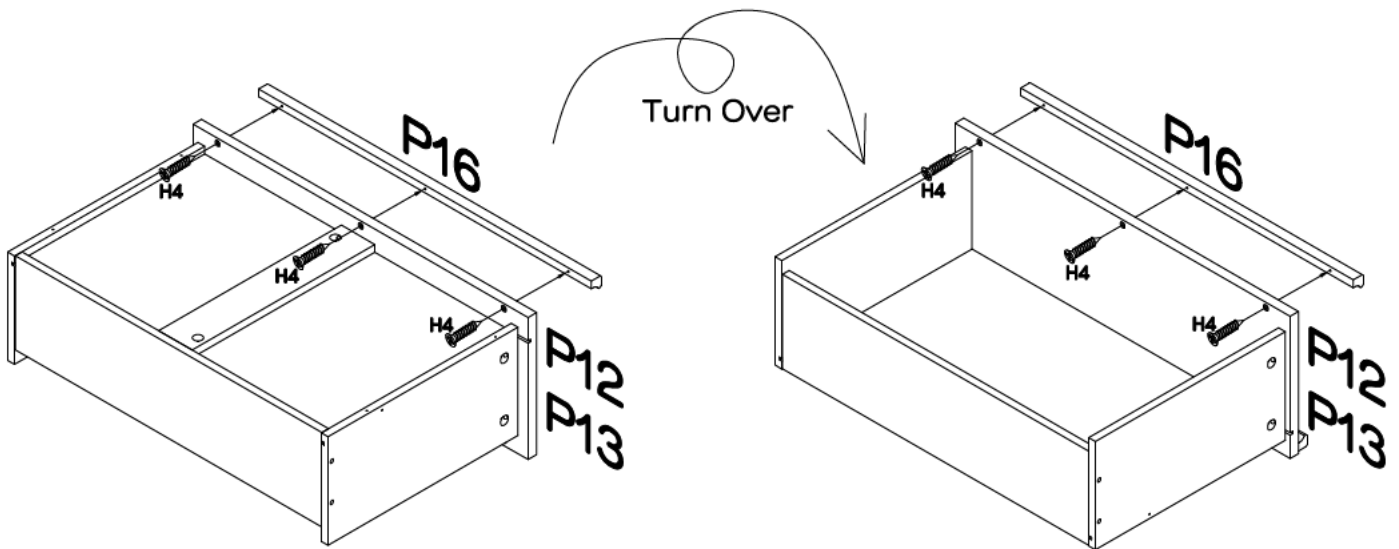
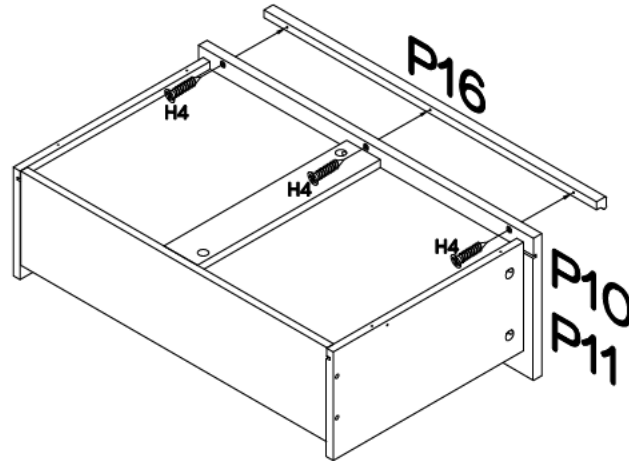
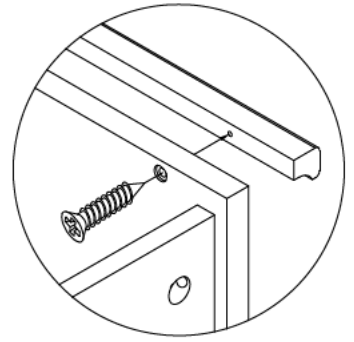
You will need

24 x Support Screws (H4)

Phillips Head Screwdriver

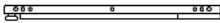

Attach 8 x handles (P16) using 24 x support screws (H4) to the drawer front panels (P10, P11, P12, P13, P14 & P15), tightening with a phillips head screwdriver. Note the positioning of the handles.

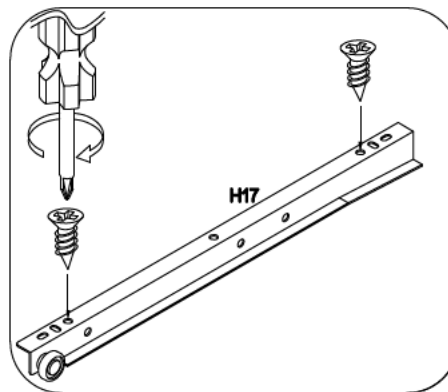
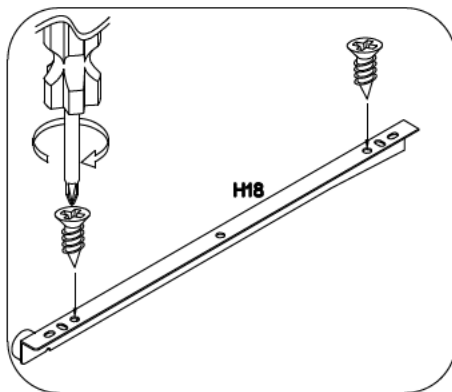
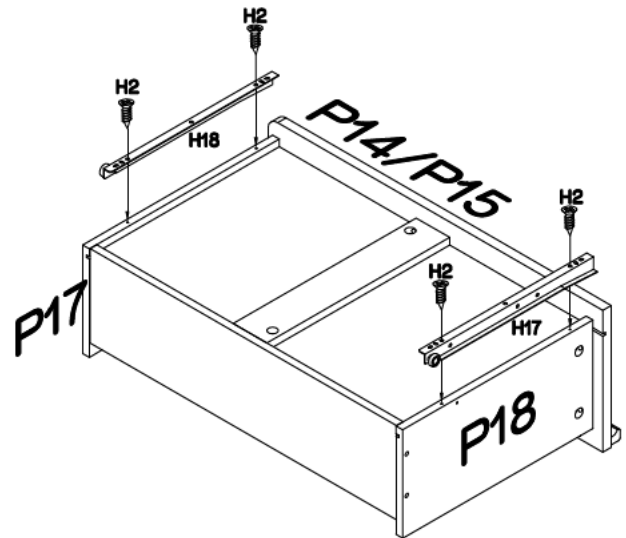
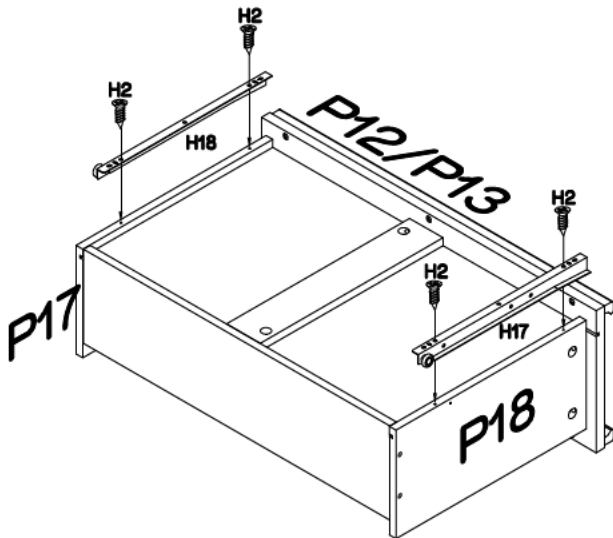
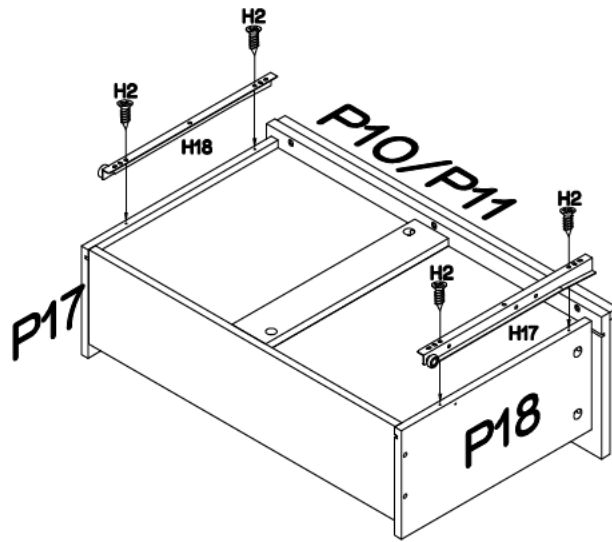
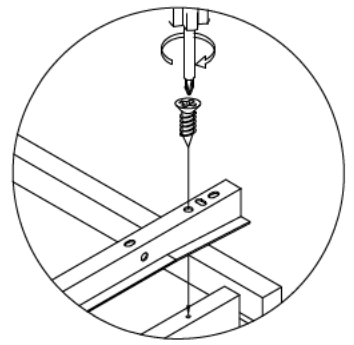
Step 21

You will need	
	
24 x Small Screws (H2)	6 x DR Runners (H17)
	
6 x DL Runners (H18)	Phillips Head Screwdriver



Attach 6 x DL runners (H18) to the drawer left side panel (P17) and 6 x DR runners (H17) to the drawer right side panel (P18) using 24 x small screws (H2), tightening with the phillips head screwdriver. Repeat this process for the other drawers.

Step 22

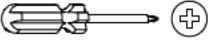
You will need

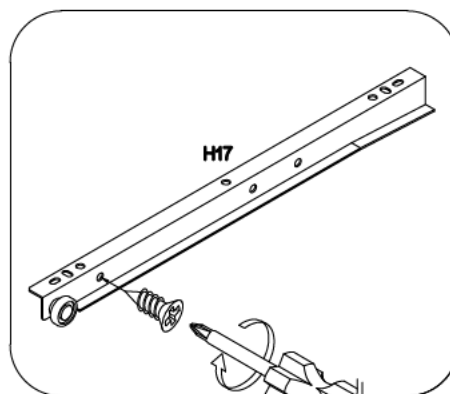
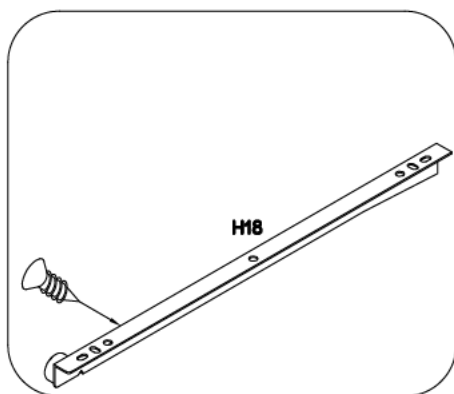
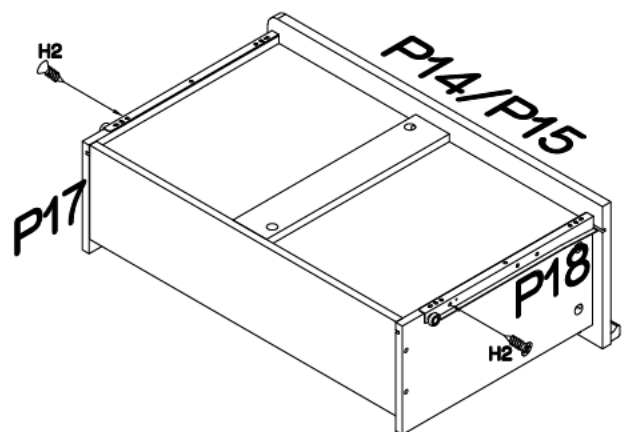
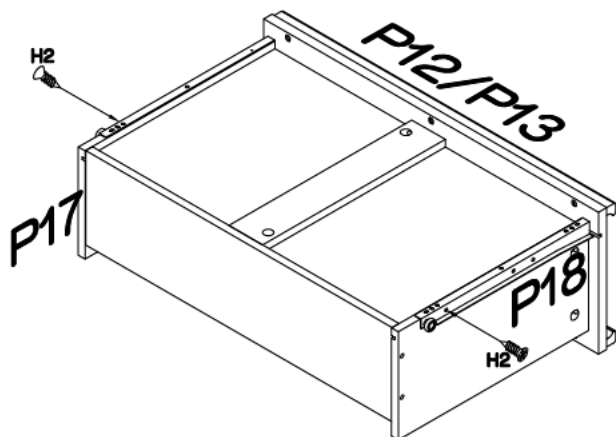
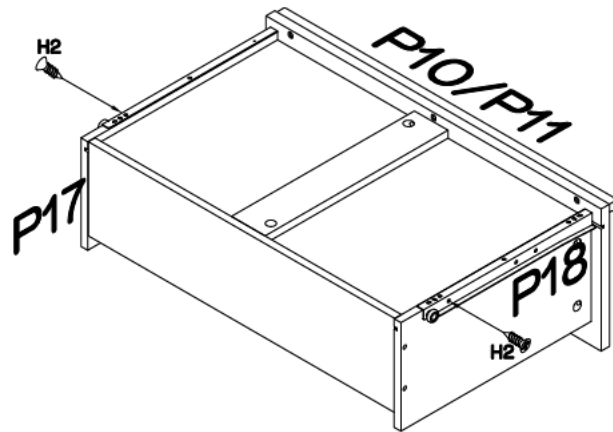
12 x Small Screws (H2)

Phillips Head Screwdriver

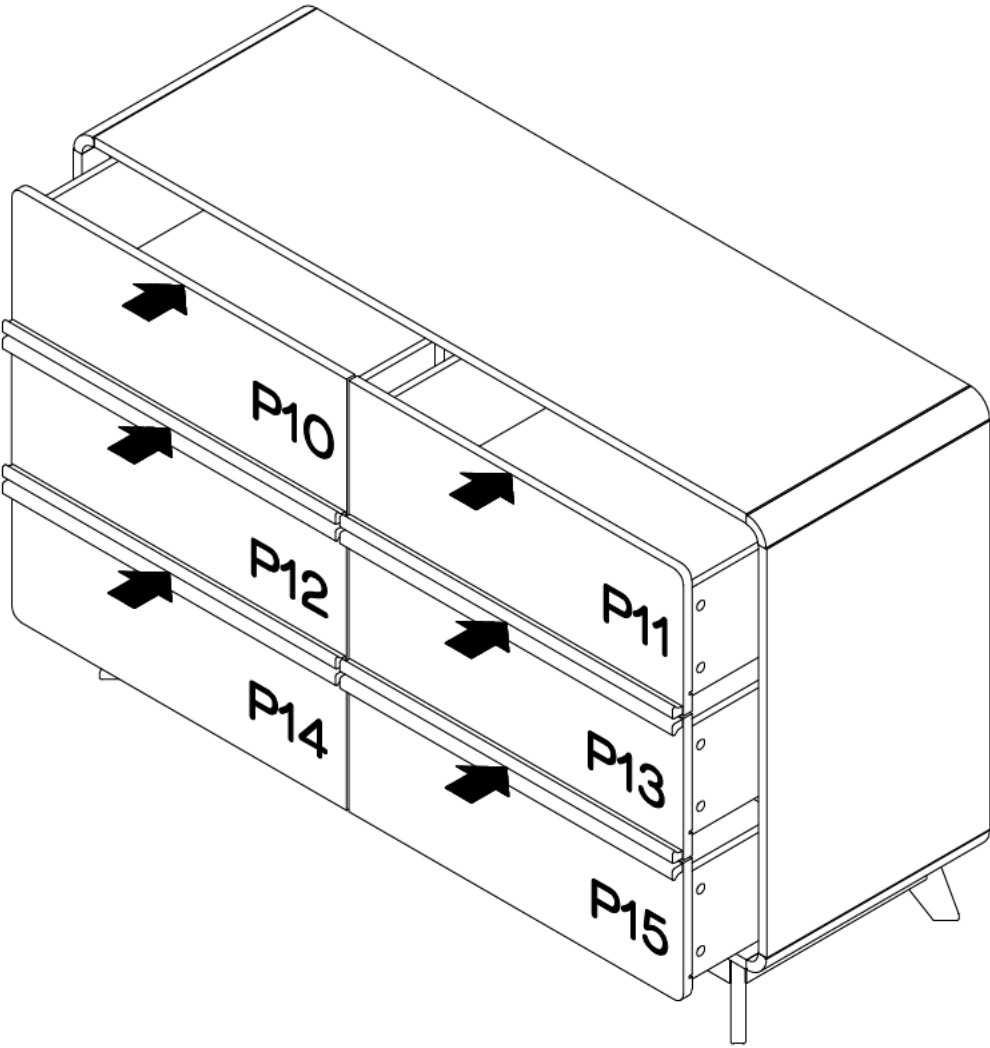

Attach DL runners (H18) to the drawer left side panel (P17) and DR runners (H17) to the drawer right side panel (P18) using 12 x small screws (H2), tightening with the phillips head screwdriver. Repeat this process for the other drawers.

Step 23



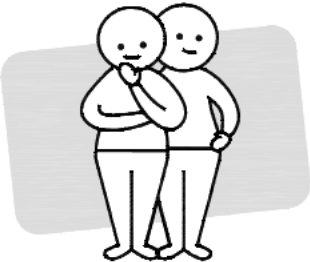

Two People



Required

With assistance, carefully turn dresser up right. Insert the completed drawer boxes into the frame as shown.

Step 24

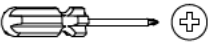
You will need

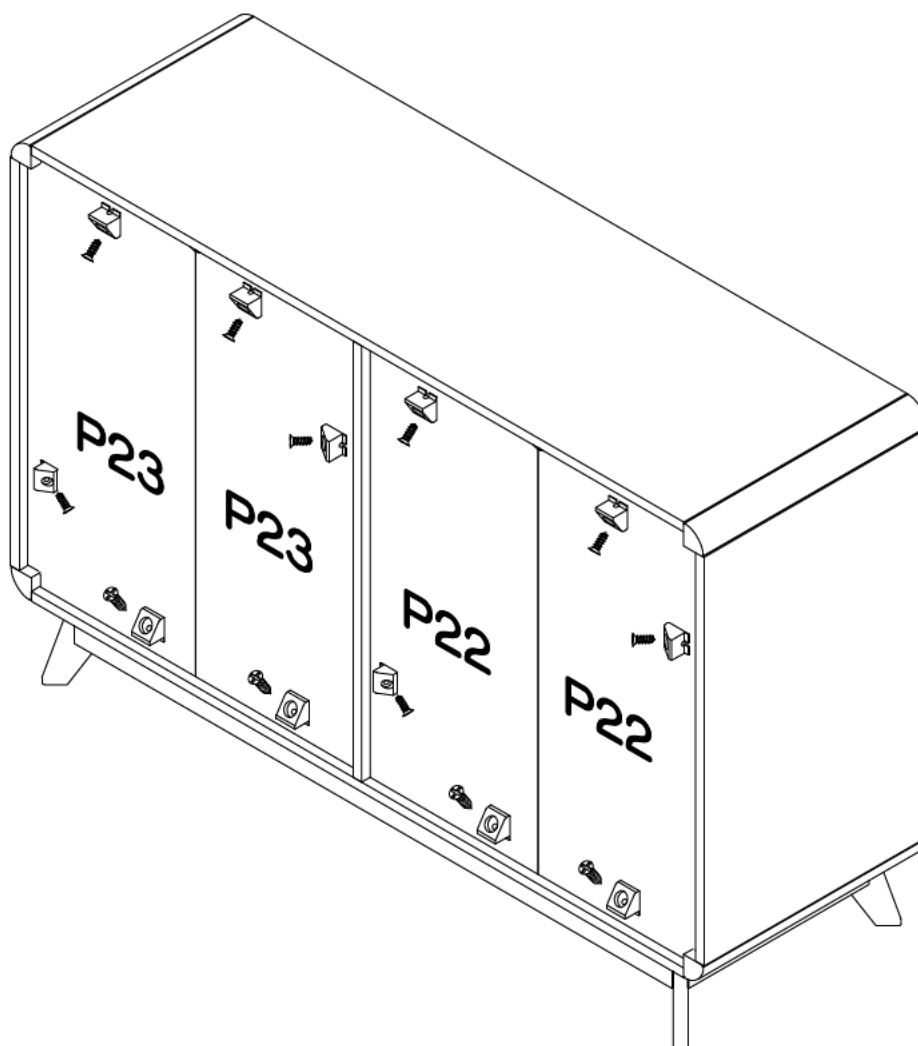
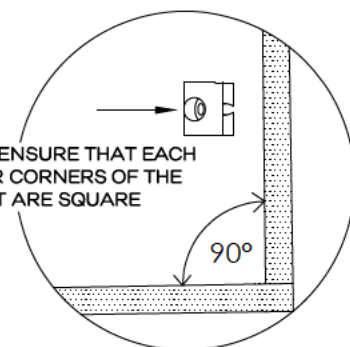
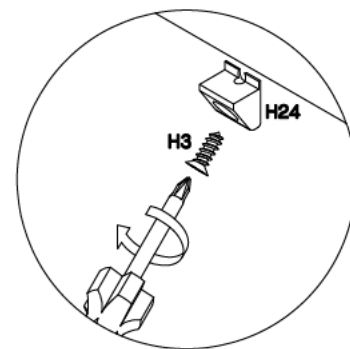
12 × Medium Screws (H3)

12 × Wedges (H24)

Phillips Head Screwdriver



Attach 12 x wedges (H24) to the 2 x left back panels (P22) and 2 x right back panel (P23) using 12 x medium screws (H3), tightening with the philips head screwdriver.

Step 25

TIPPING RESTRAINTS KIT INSTALLATION GUIDANCE

This tipping restraint is not an earthquake restraint. If you wish to add the extra security of earthquake restraints, they must be purchased and installed separately.

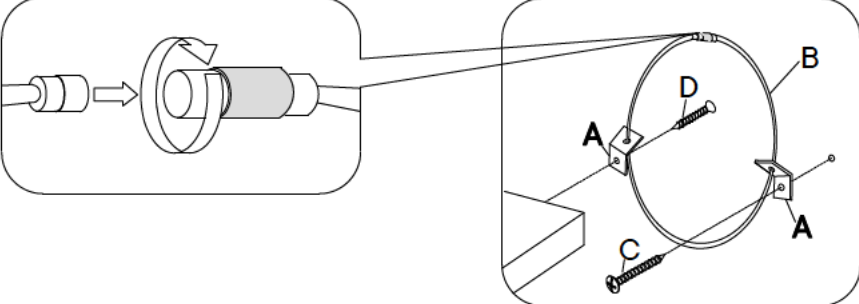
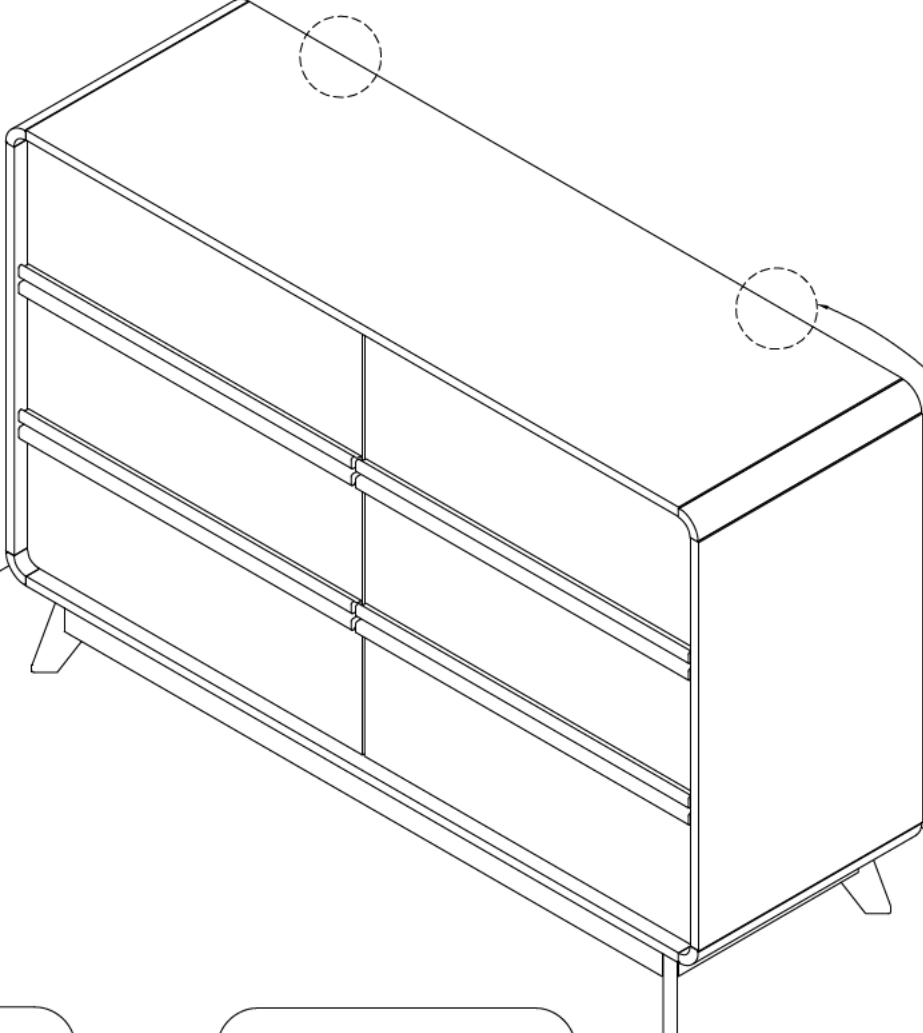
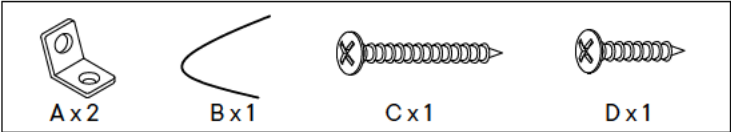

Step 26



Job Complete!
**In the interest of our
environment please dispose of
all packaging thoughtfully.**