

ASSEMBLY INSTRUCTIONS

Ax1

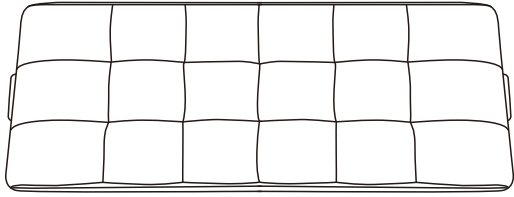

Bx1

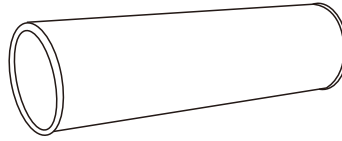

Cx1

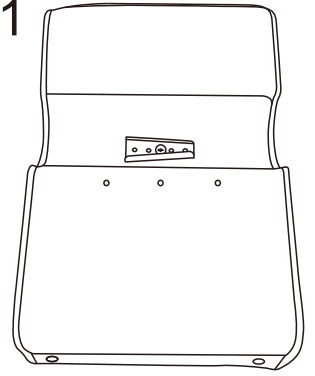

Dx1

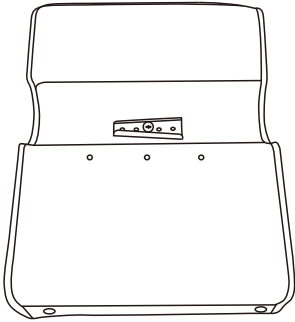

Ex2

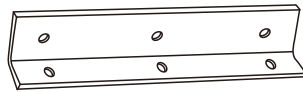

Fx12

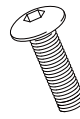

Gx1



STEP 1

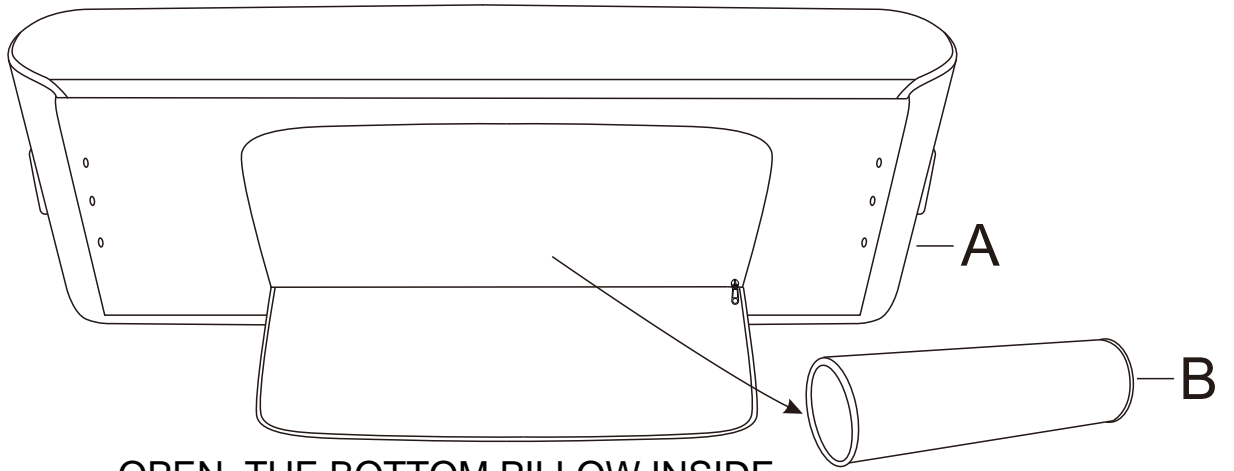

OPEN THE BOTTOM, PILLOW INSIDE.

STEP 2

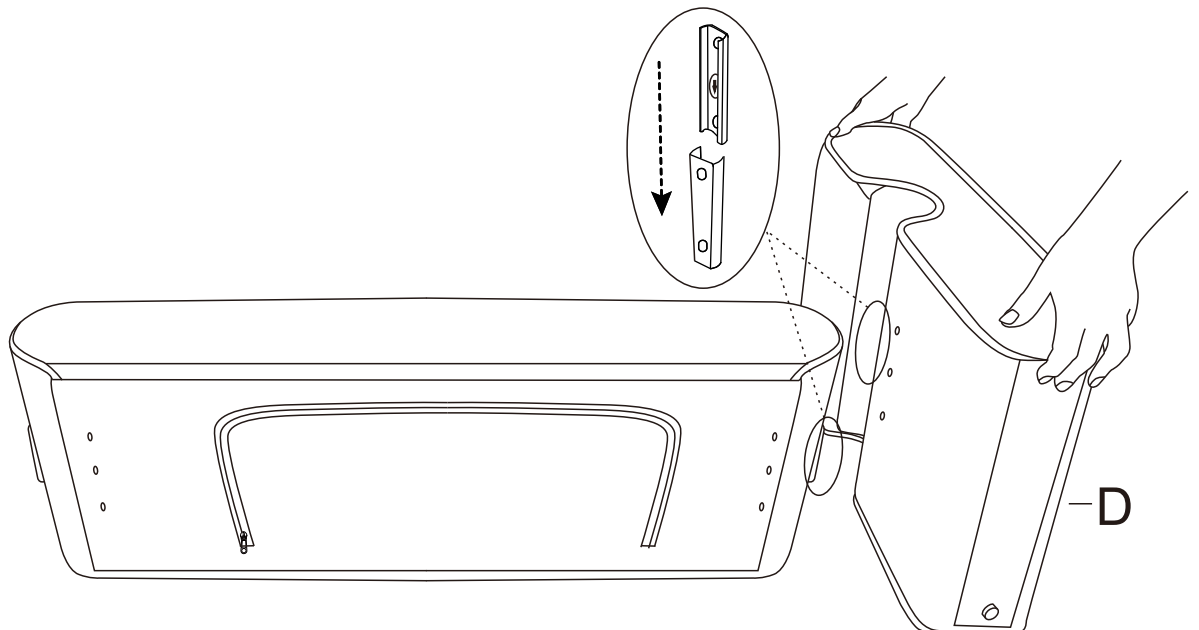

STEP 3

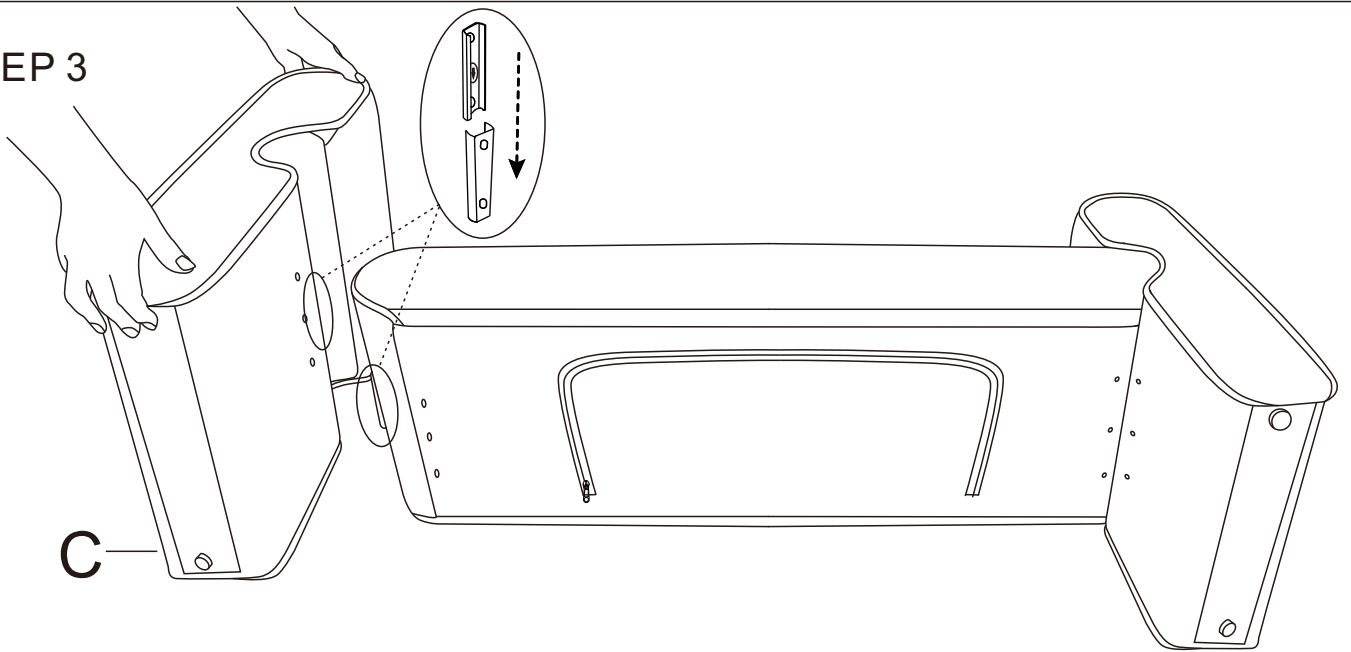

STEP 4

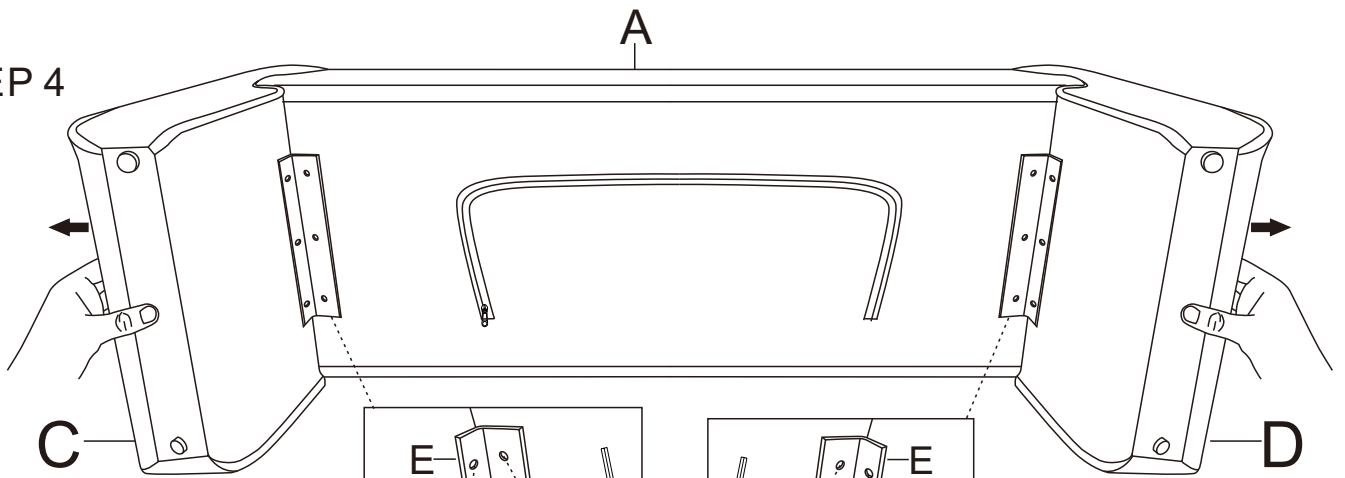

Turn C outward so that the holes in E align with the holes in C and A.

Turn D outward so that the holes in E align with the holes in D and A.

STEP 5

