

ASSEMBLY INSTRUCTION

SKU CODE:

Warning: You must read this before continuing
INSTRUCTIONS DE MONTAGE

SKU NUMBER:

Attention: Vous devez lire ceci avant de continuer

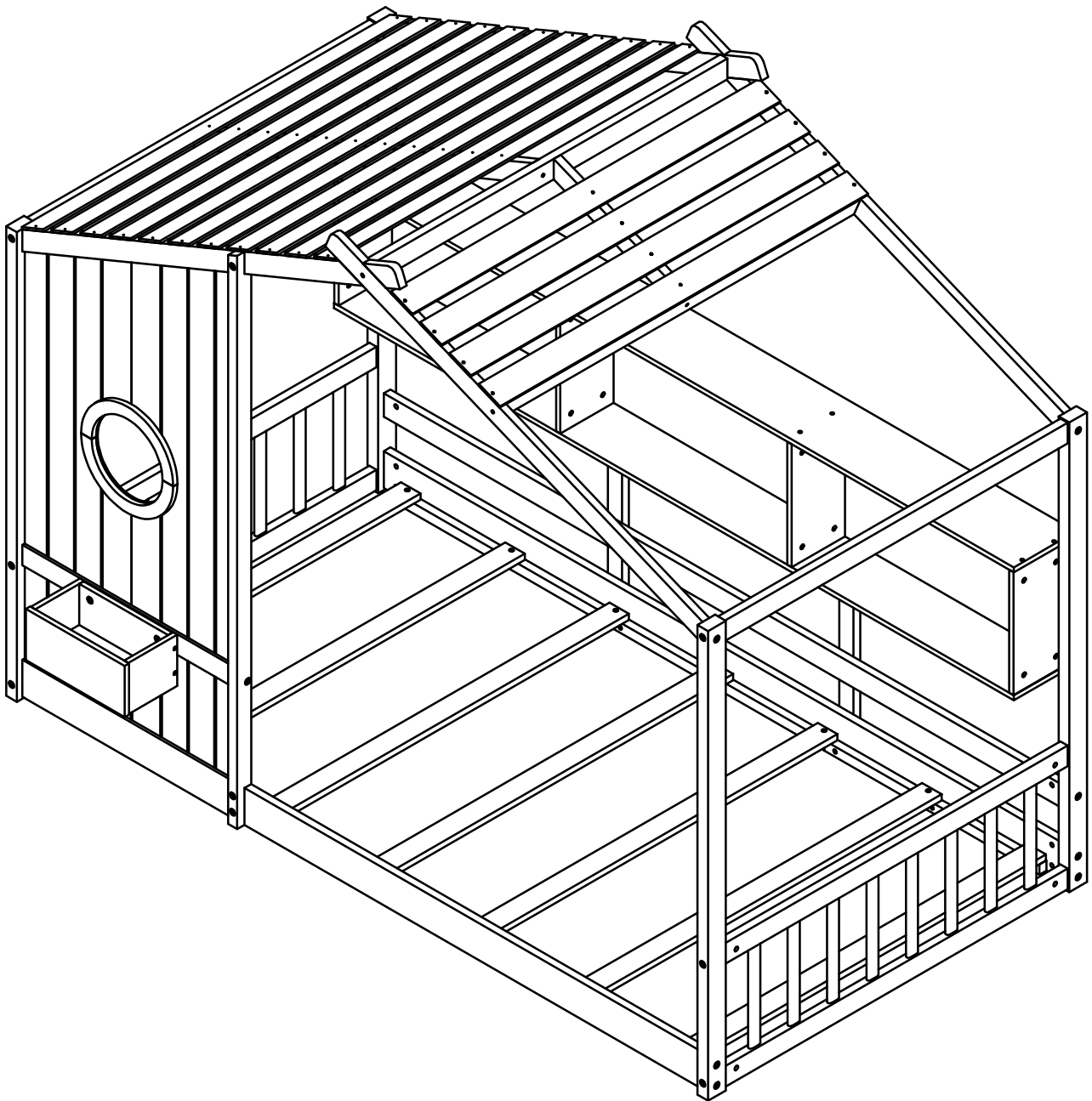

SAFETY WARNINGS AND GENERAL NOTES:

1. Do not use substitute parts. Contact the manufacturer or dealer for replacement parts.
2. Keep these instructions for future reference.
3. We recommend assembling your bed on the shipping carton to protect your floor.
4. Be certain all staples are out of the box before beginning assembly on the shipping carton.

AVERTISSEMENTS DE SÉCURITÉ ET REMARQUES GÉNÉRALES :

1. N'utilisez pas de pièces de rechange. Contactez le fabricant ou le revendeur pour les pièces de rechange.
2. Conservez ces instructions pour référence future.
3. Nous vous recommandons d'assembler votre lit sur le carton d'expédition pour protéger votre sol.
4. Assurez-vous que toutes les agrafes sont sorties de la boîte avant de commencer l'assemblage sur le carton d'expédition.





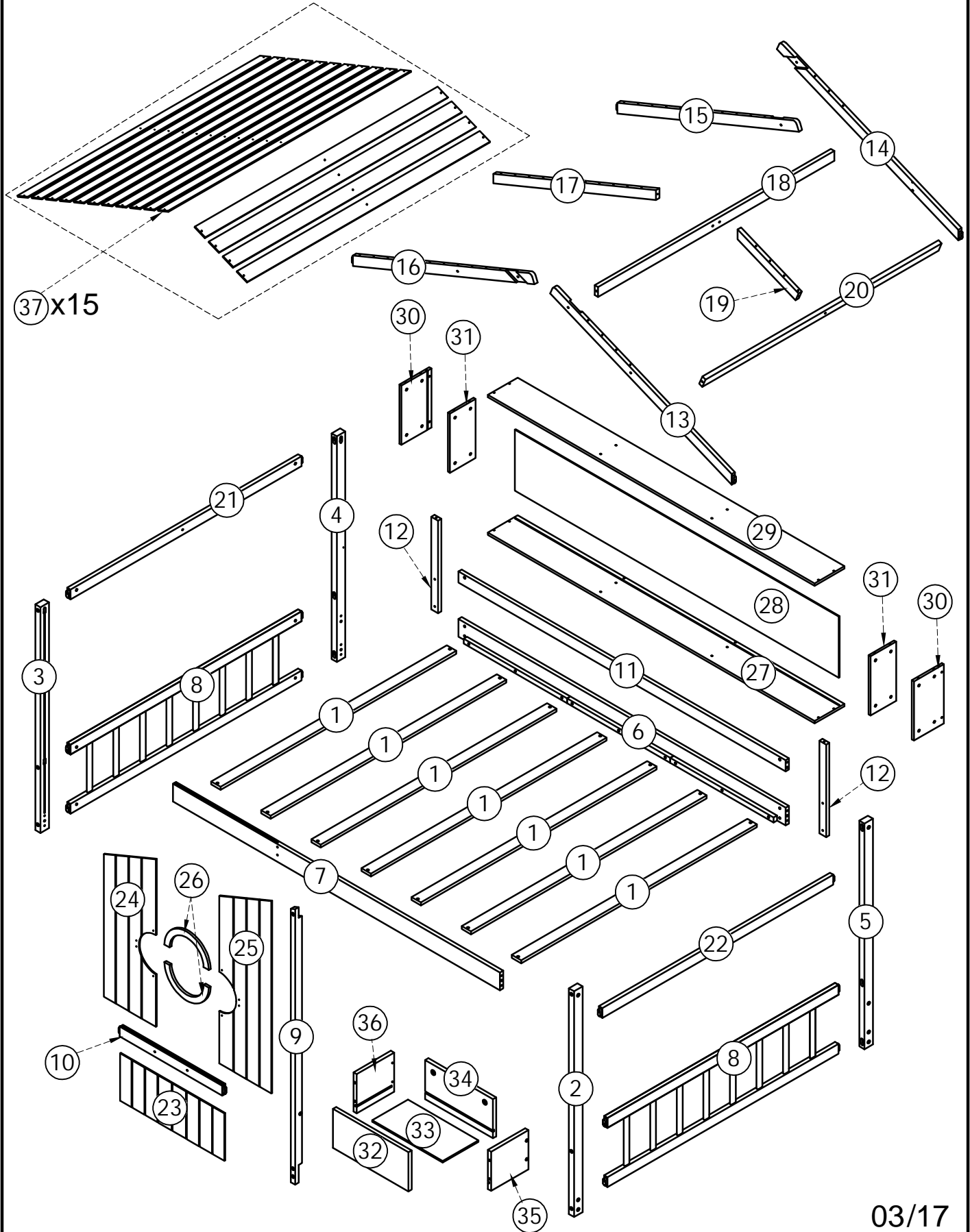





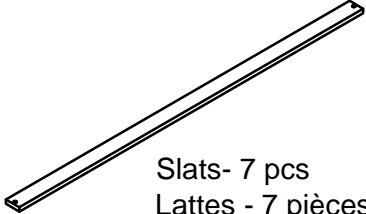

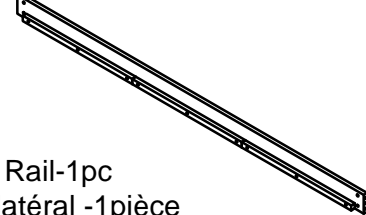
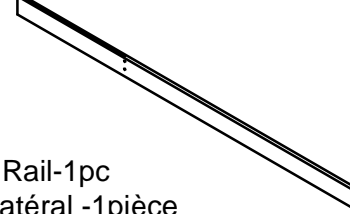
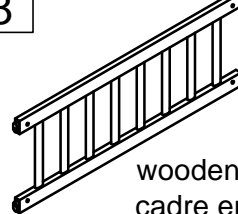

ASSEMBLY INSTRUCTION

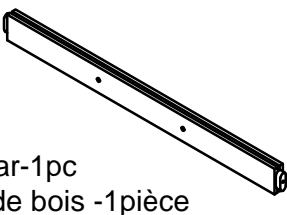
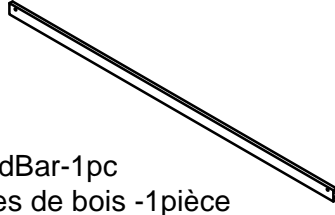
INSTRUCTIONS DEMONTAGE

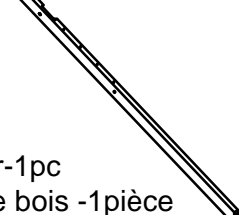
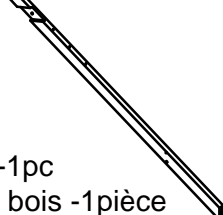



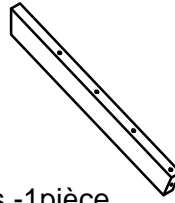

Part List & Hardware List

Liste des pièces et liste du matériel

<p>1</p>  <p>Slats- 7 pcs Lattes - 7 pièces</p>	<p>2</p>  <p>Leg-1pc Jambe -1pièce</p>	<p>3</p>  <p>Leg-1pc Jambe -1pièce</p>
<p>4</p>  <p>Leg-1pc Jambe -1pièce</p>	<p>5</p>  <p>Leg-1pc Jambe -1pièce</p>	<p>6</p>  <p>Side Rail-1pc Rail latéral -1pièce</p>
<p>7</p>  <p>Side Rail-1pc Rail latéral -1pièce</p>	<p>8</p>  <p>wooden frame- 2pcs cadre en bois- 2pièces</p>	<p>9</p>  <p>WoodBar-1pc Barres de bois -1pièce</p>
<p>10</p>  <p>WoodBar-1pc Barres de bois -1pièce</p>	<p>11</p>  <p>WoodBar-1pc Barres de bois -1pièce</p>	<p>12</p>  <p>WoodBar-2 pcs Barres de bois - 2pièces</p>
<p>13</p>  <p>WoodBar-1pc Barres de bois -1pièce</p>	<p>14</p>  <p>WoodBar-1pc Barres de bois -1pièce</p>	<p>15</p>  <p>WoodBar-1pc Barres de bois -1pièce</p>
<p>16</p>  <p>WoodBar-1pc Barres de bois -1pièce</p>	<p>17</p>  <p>WoodBar-1pc Barres de bois -1pièce</p>	<p>18</p>  <p>WoodBar-1pc Barres de bois -1pièce</p>
<p>19</p>  <p>WoodBar-1pc Barres de bois -1pièce</p>	<p>20</p>  <p>WoodBar-1pc Barres de bois -1pièce</p>	<p>21</p>  <p>WoodBar-1pc Barres de bois -1pièce</p>

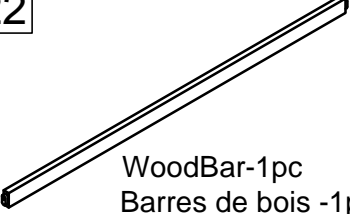
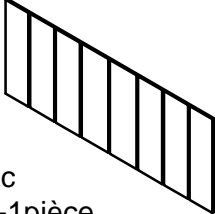

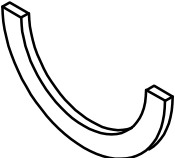
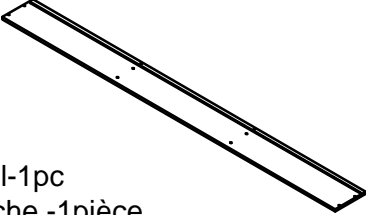
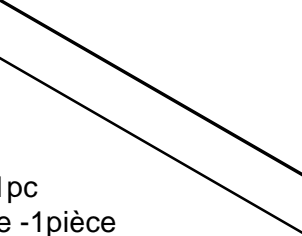
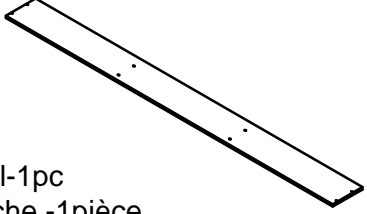
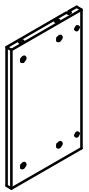

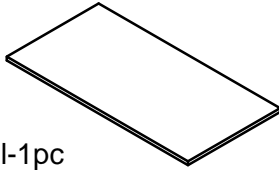
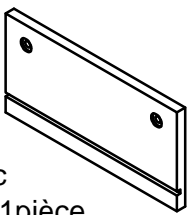
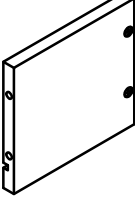
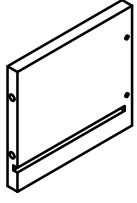
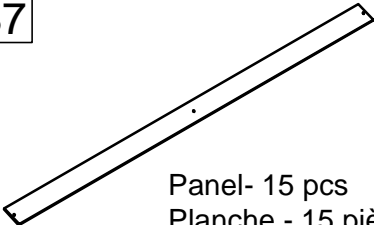

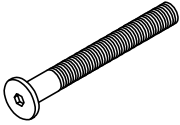
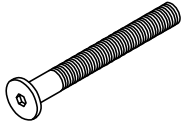
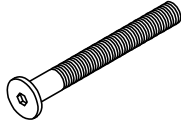
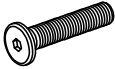
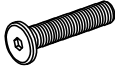

Part List & Hardware List

Liste des pièces et liste du matériel

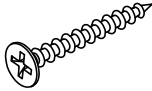
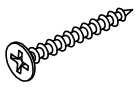
<p>22</p>  <p>WoodBar-1pc Barres de bois -1pièce</p>	<p>23</p>  <p>Panel-1pc Planche -1pièce</p>	<p>24</p>  <p>Panel-1pc Planche -1pièce</p>
<p>25</p>  <p>Panel-1pc Planche -1pièce</p>	<p>26</p>  <p>WoodBar-2 pcs Barres de bois - 2pièces</p>	<p>27</p>  <p>Panel-1pc Planche -1pièce</p>
<p>28</p>  <p>Panel-1pc Planche -1pièce</p>	<p>29</p>  <p>Panel-1pc Planche -1pièce</p>	<p>30</p>  <p>Panel-2pcs Planche -2pièces</p>
<p>31</p>  <p>Panel-2pcs Planche -2pièces</p>	<p>32</p>  <p>Panel-1pc Planche -1pièce</p>	<p>33</p>  <p>Panel-1pc Planche -1pièce</p>
<p>34</p>  <p>Panel-1pc Planche -1pièce</p>	<p>35</p>  <p>Panel-1pc Planche -1pièce</p>	<p>36</p>  <p>Panel-1pc Planche -1pièce</p>
<p>37</p>  <p>Panel- 15 pcs Planche - 15 pièces</p>		

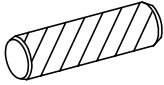
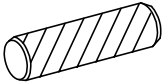
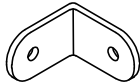
Hardware List

Liste du matériel

<p>A</p>  <p>Bolt Ø6 x 90 mm-12 pcs Boulon Ø6 x 90 mm-12 pièces</p>	<p>B</p>  <p>Bolt Ø6 x 70 mm-12 pcs Boulon Ø6 x 70 mm-12 pièces</p>	<p>C</p>  <p>Bolt Ø6 x 60 mm-22 pcs Boulon Ø6 x 60 mm-22 pièces</p>
<p>D</p>  <p>Bolt Ø6 x 35 mm-3 pcs Boulon Ø6 x 35 mm-3 pièces</p>	<p>E</p>  <p>Bolt Ø6 x 20 mm-2 pcs Boulon Ø6 x 20 mm-2 pièces</p>	<p>F</p>  <p>Screws Ø6 x 55mm - 8 pcs Vis Ø6 x 55mm- 8 pièces</p>
<p>G</p>  <p>Screws Ø6 x 35mm - 8 pcs Vis Ø6 x 35mm- 8 pièces</p>	<p>H</p>  <p>Wood Screws M4 x 30mm -18 pcs Les vis à bois M4 x 30mm -18 pièces</p>	<p>K</p>  <p>Wood Screws M3.5 x 12mm -4 pcs Les vis à bois M3.5 x 12mm- 4 pièces</p>
<p>L</p>  <p>Wood Screws M4 x 15mm -53 pcs Les vis à bois M4 x 15mm- 53 pièces</p>	<p>M</p>  <p>Wood dowel Ø10 x 40mm - 6 pcs Cheville en bois Ø10 x 40mm - 6 pièces</p>	<p>N</p>  <p>Wood dowel Ø6 x 25mm - 4pcs Cheville en bois Ø6 x 25mm - 4pièces</p>
<p>P</p>  <p>Angle Metal 17*17*1 - 2 pcs Angle métallique 17*17*1- 2 pièces</p>	<p>Q</p>  <p>Ø6 x 13 mm - 46 pcs Ø6 x 13 mm - 46 pièces</p>	<p>R</p>  <p>Ø6 x 15 mm - 5 pcs Ø6 x 15 mm - 5 pièces</p>
<p>S</p>  <p>Allen Key - 1pc Clé Allen - 1pc</p>		

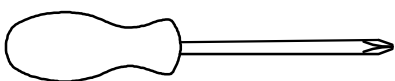



Assembly Tools Required (Not Included)
Outils d'assemblage requis (non inclus)

STEP 1:

Étape 1:

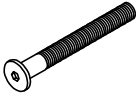

$D2 > D1$.

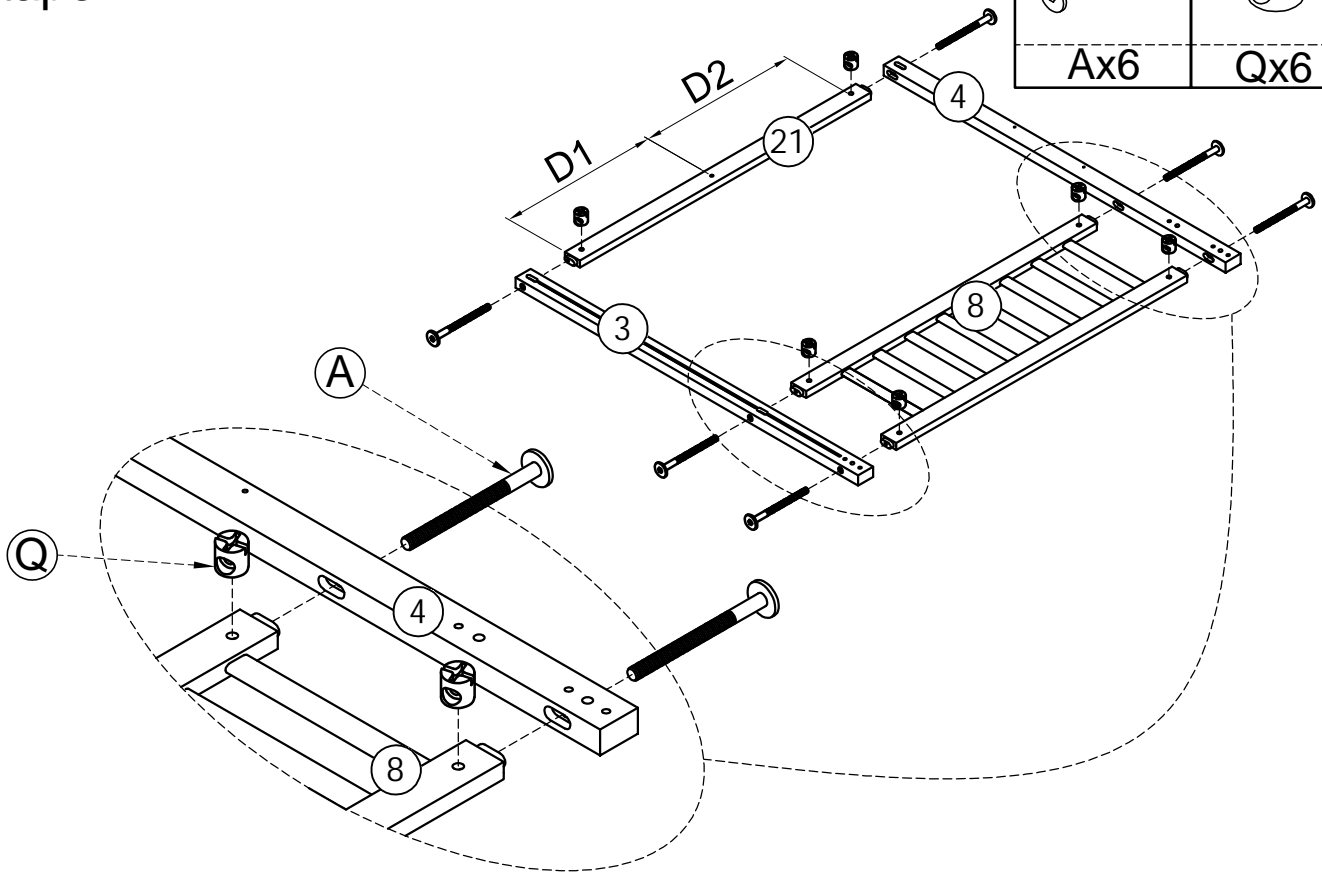
$\text{Ø}6 \times 90 \text{mm}$	$\text{Ø}6 \times 13 \text{mm}$
	
Ax6	Qx6



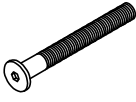

STEP 2:

Étape 2:

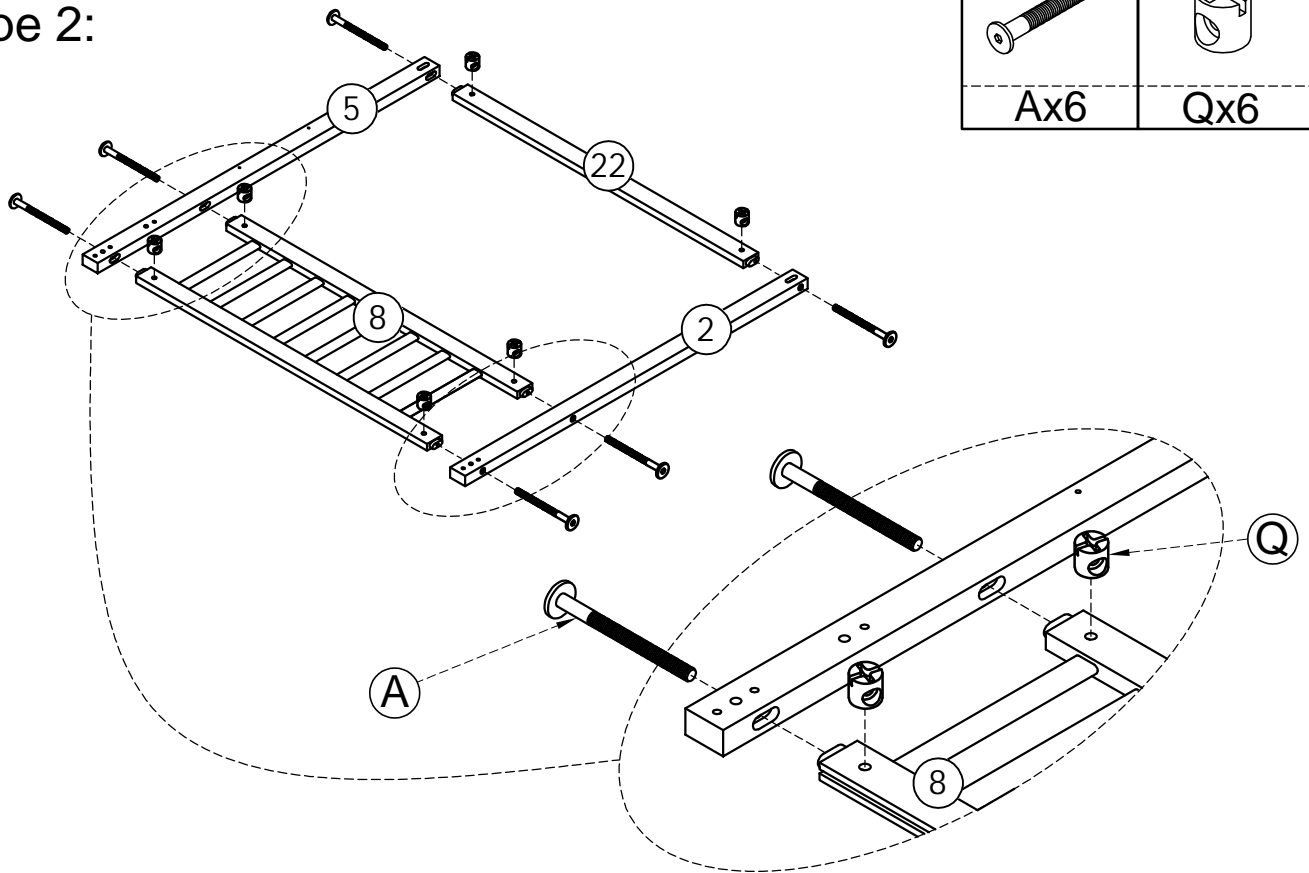
$\text{Ø}6 \times 90 \text{mm}$	$\text{Ø}6 \times 13 \text{mm}$
	
Ax6	Qx6



STEP 3:
Étape 3:

Ø10x40mm  Mx4	Ø6x70mm  Bx6	Ø6x13mm  Qx6
--	---	---

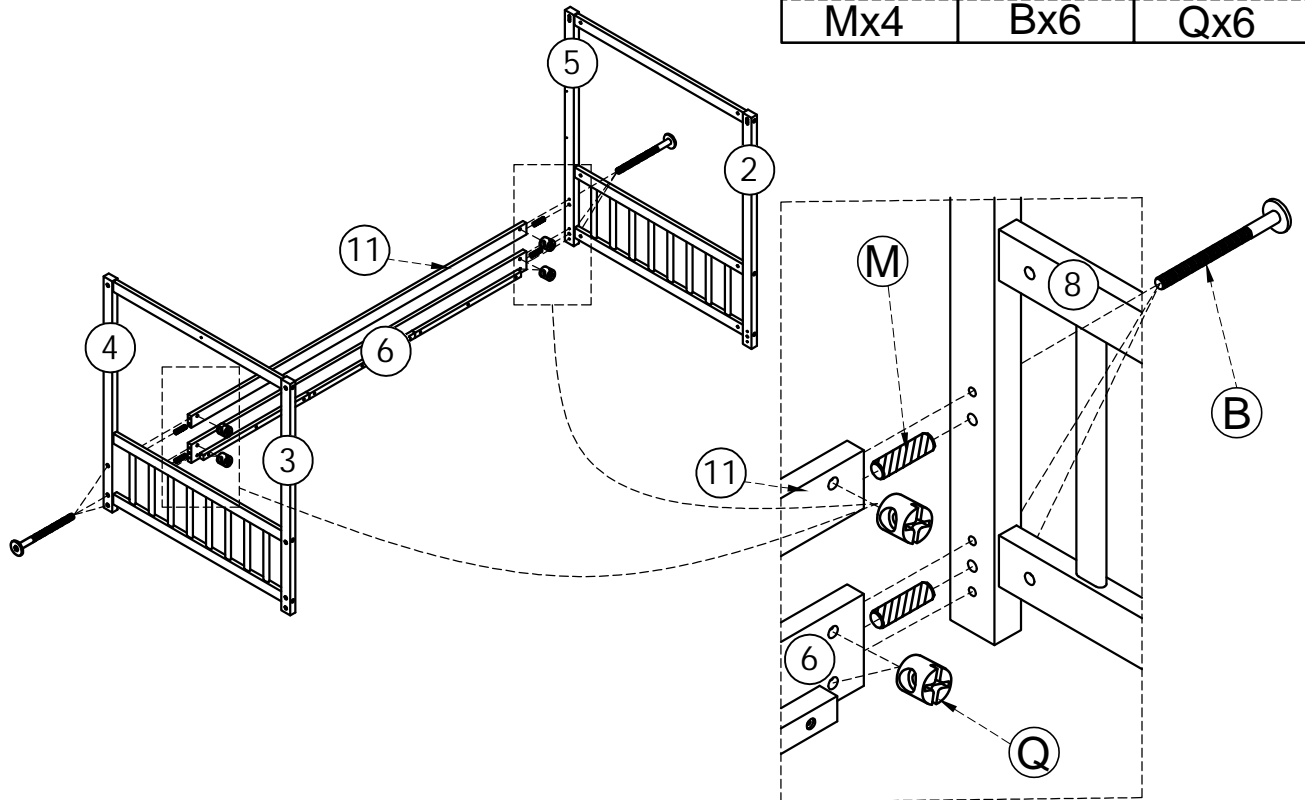

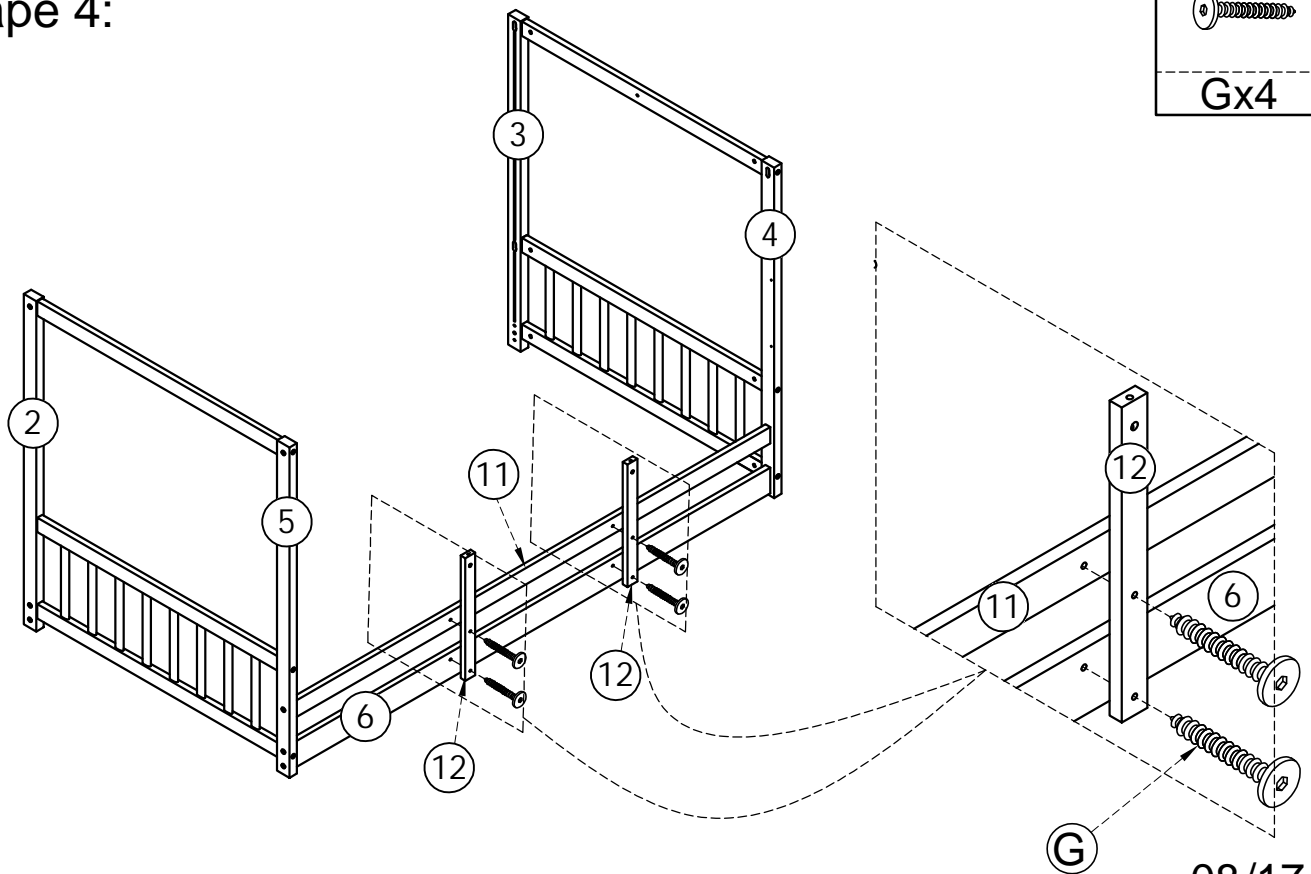

STEP 4:
Étape 4:

Ø6x35mm  Gx4



STEP 5:

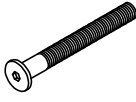

Étape 5:

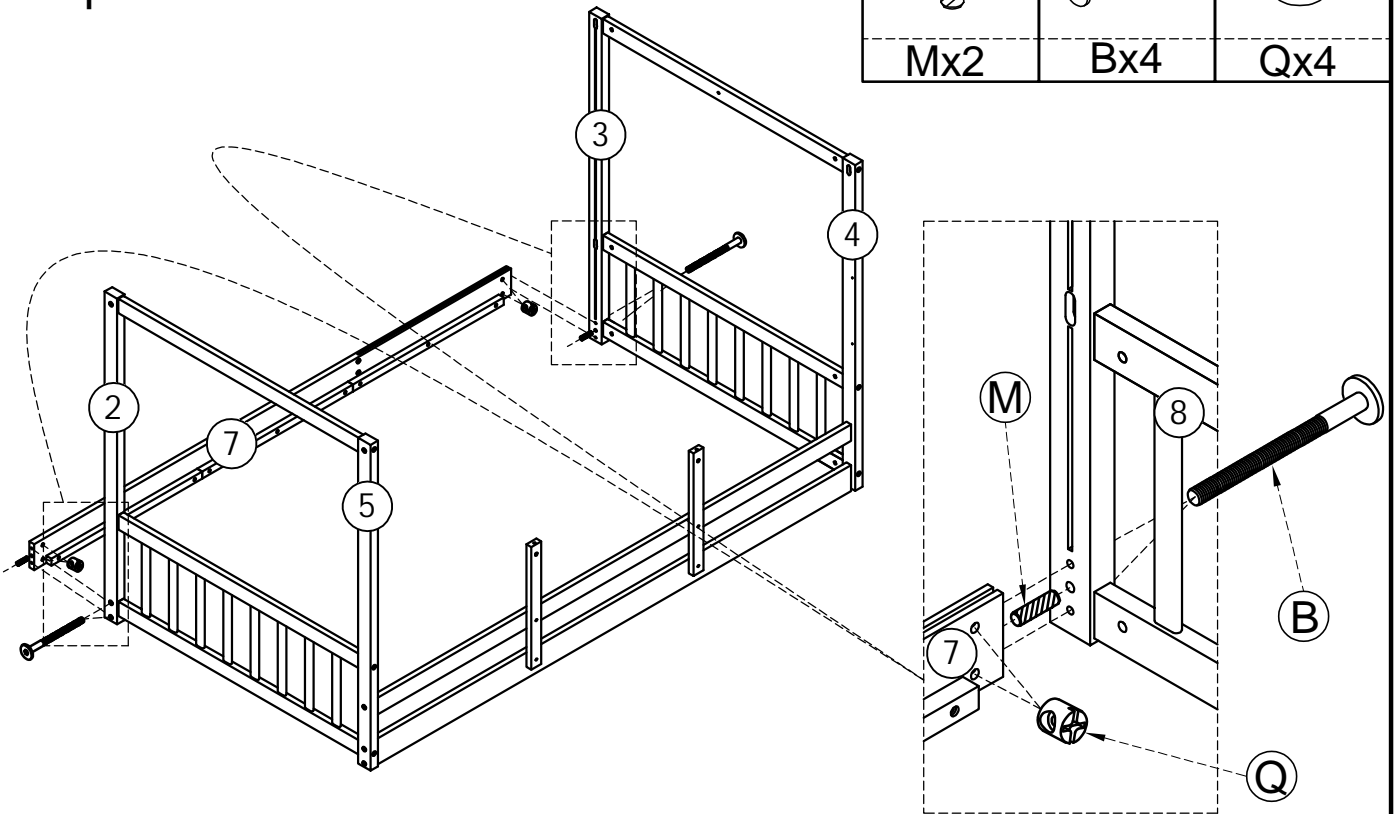
Ø10x40mm  Mx2	Ø6x70mm  Bx4	Ø6x13mm  Qx4
--	---	---

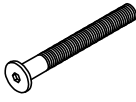

STEP 6-1:

Étape 6-1:

Ø6x60mm  Cx8	Ø6x13mm  Qx8
---	---

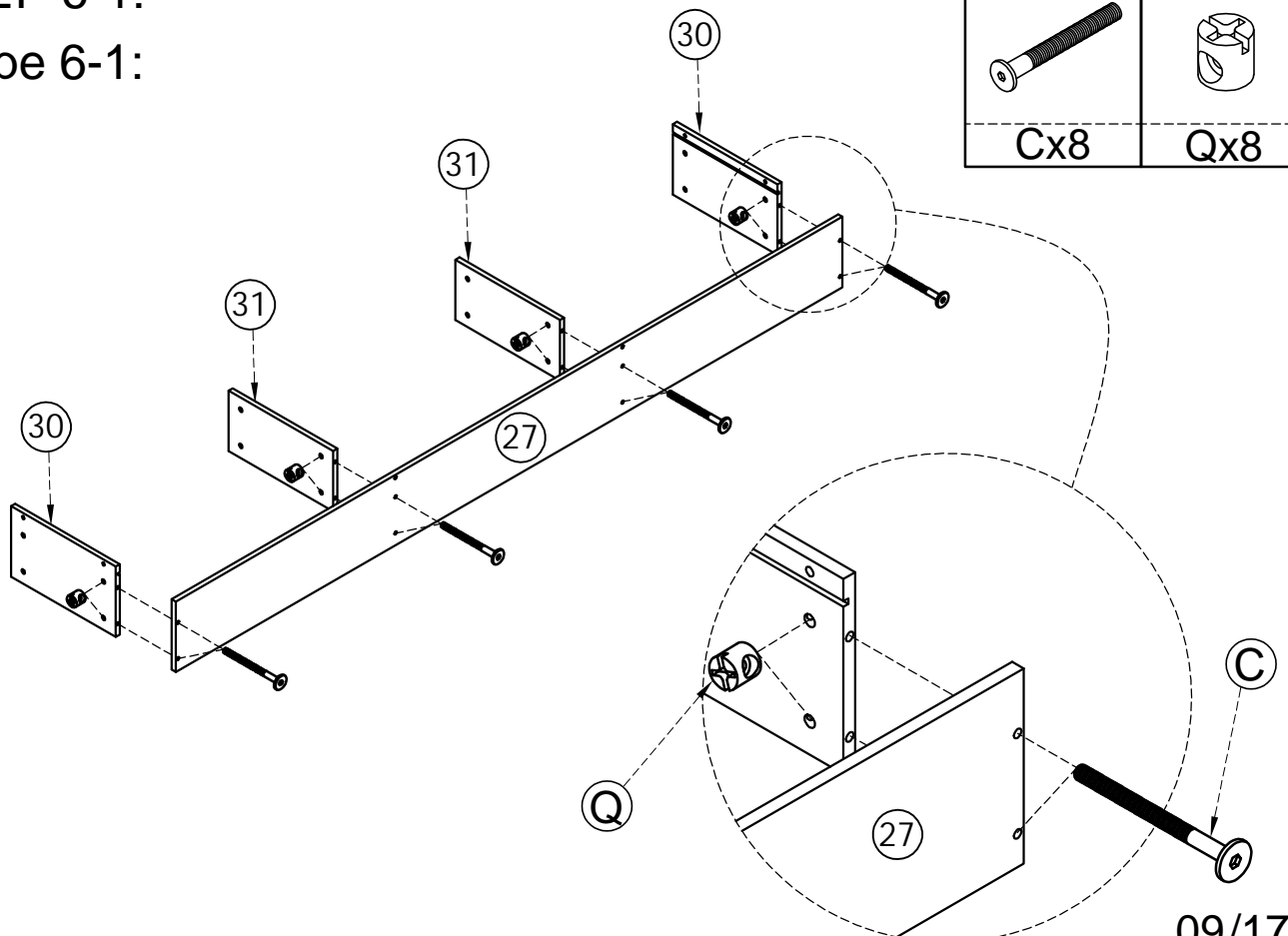

STEP 6-2:

Étape 6-2:

Ø6x60mm

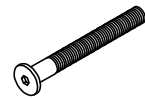

Cx8

Ø6x13mm



Qx8

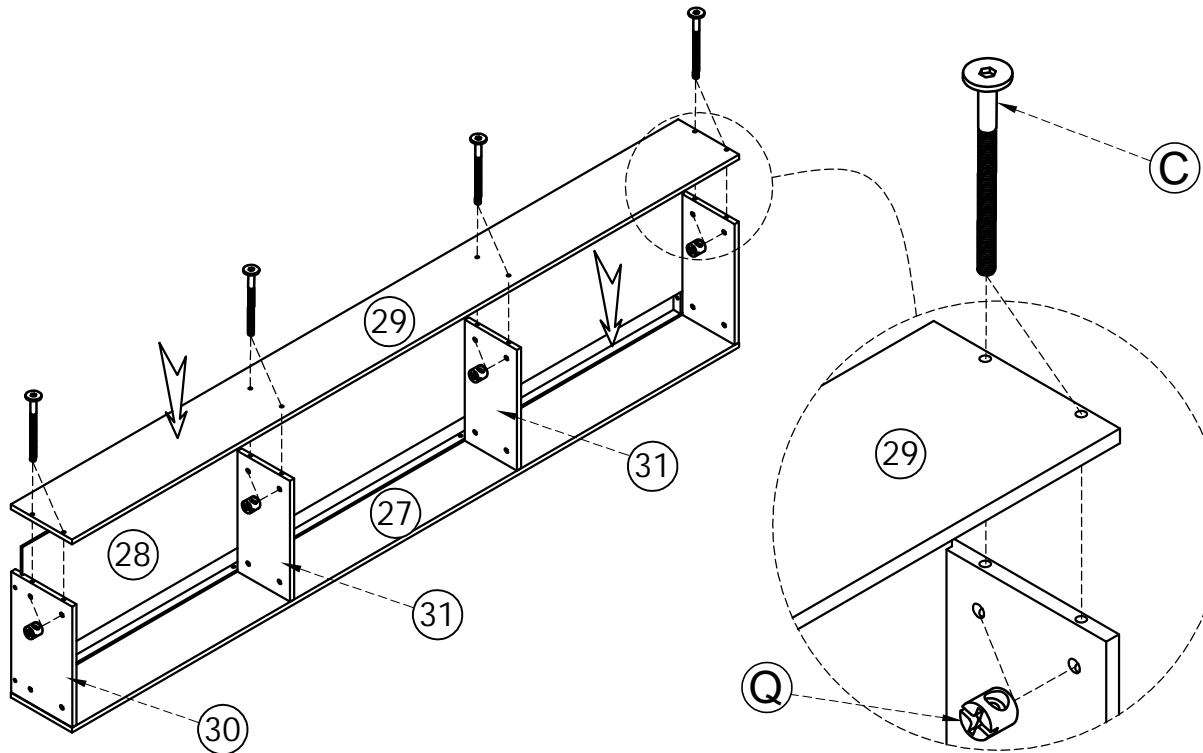

STEP 7:

Étape 7:

Ø6x60mm

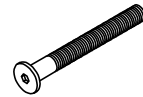

Cx2

Ø6x13mm



Qx2

Ø6x35mm



Gx4

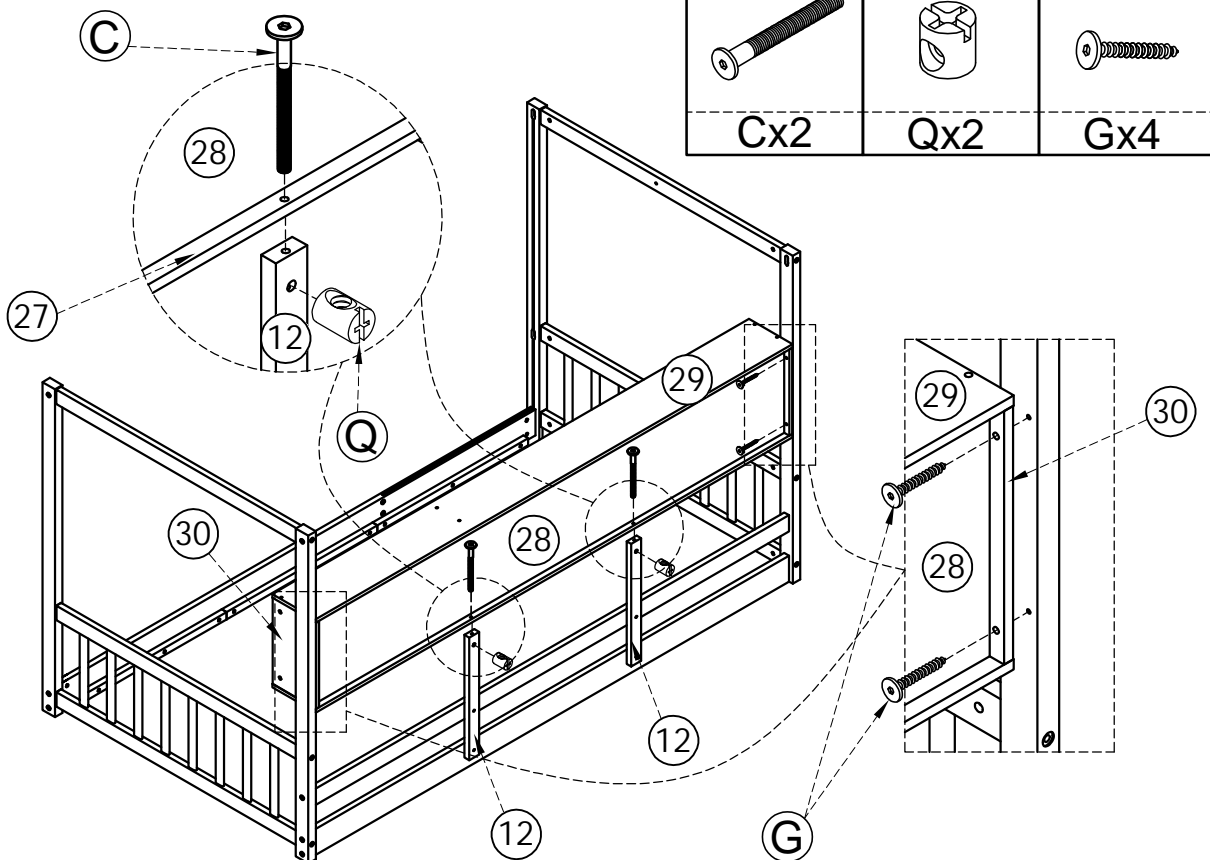

STEP 8:

Étape 8:

Ø6x70mm

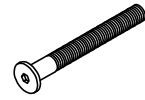

Bx1

Ø6x13mm



Qx1

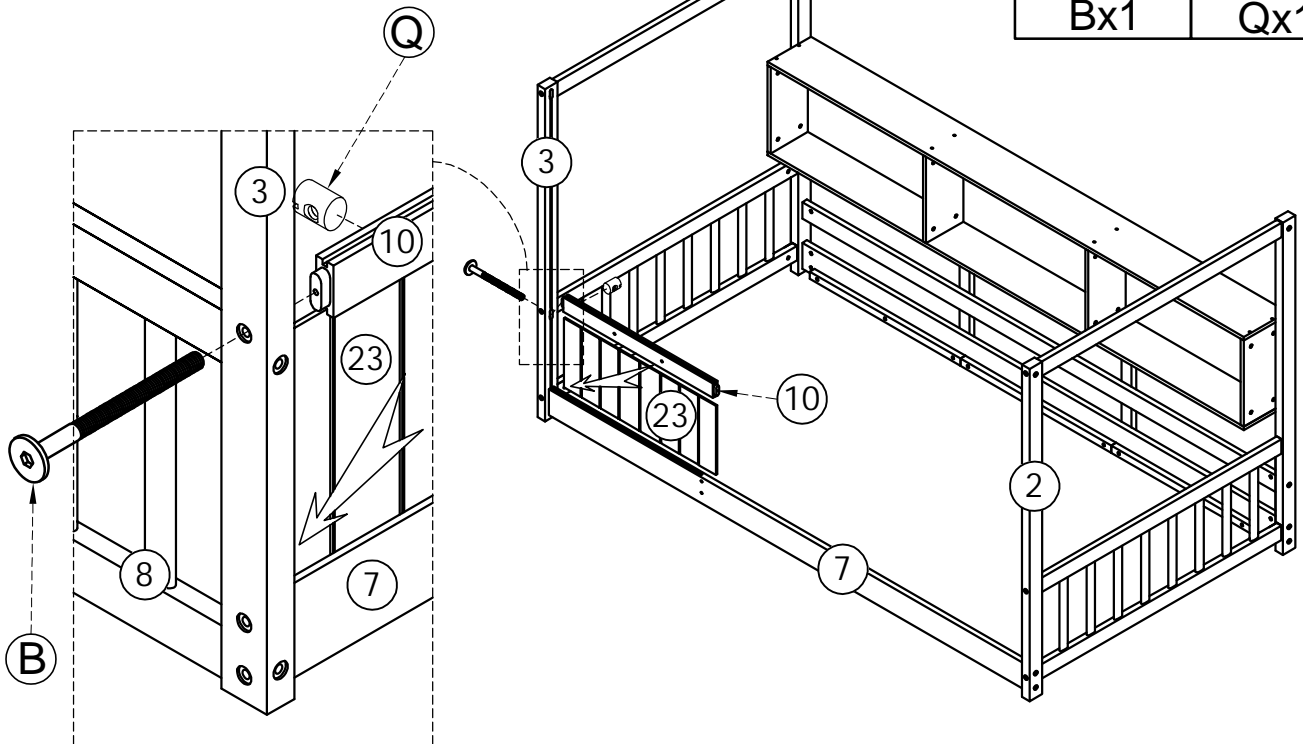

STEP 9-1:

Étape 9-1:

M4x15mm



Lx8

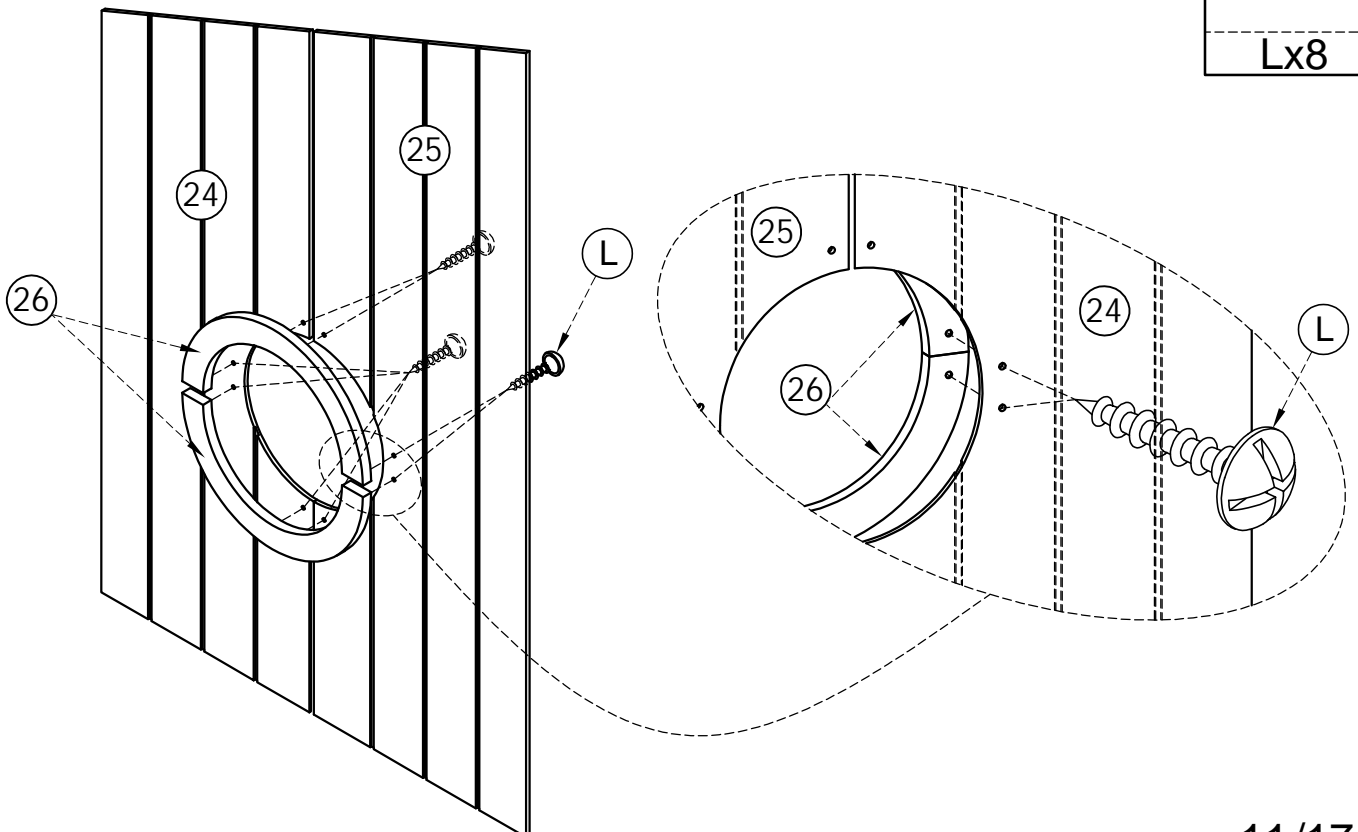



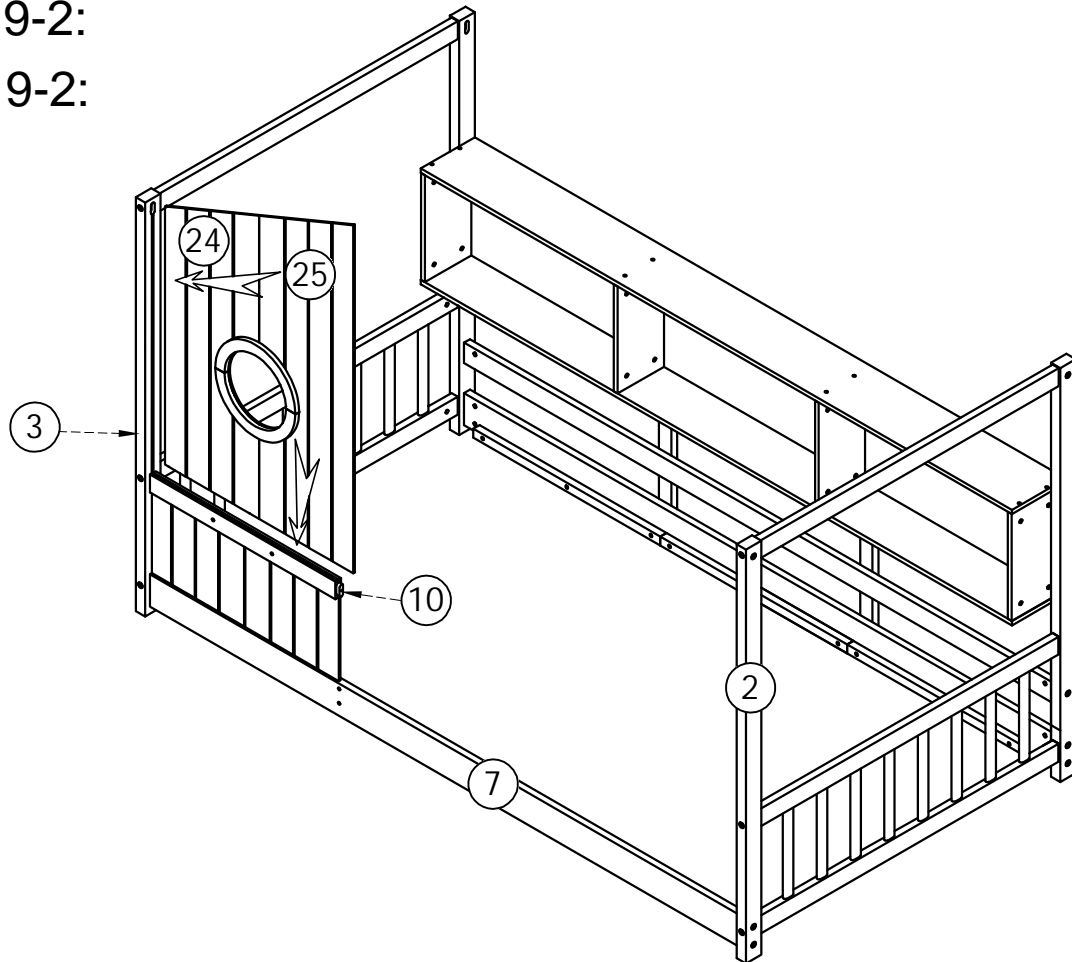

STEP 9-2:

Étape 9-2:

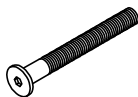

STEP 10:

Étape 10:

Ø6x70mm	Ø6x13mm	Ø6x35mm	Ø6x15mm
			
Bx1	Qx1	Dx2	Rx2

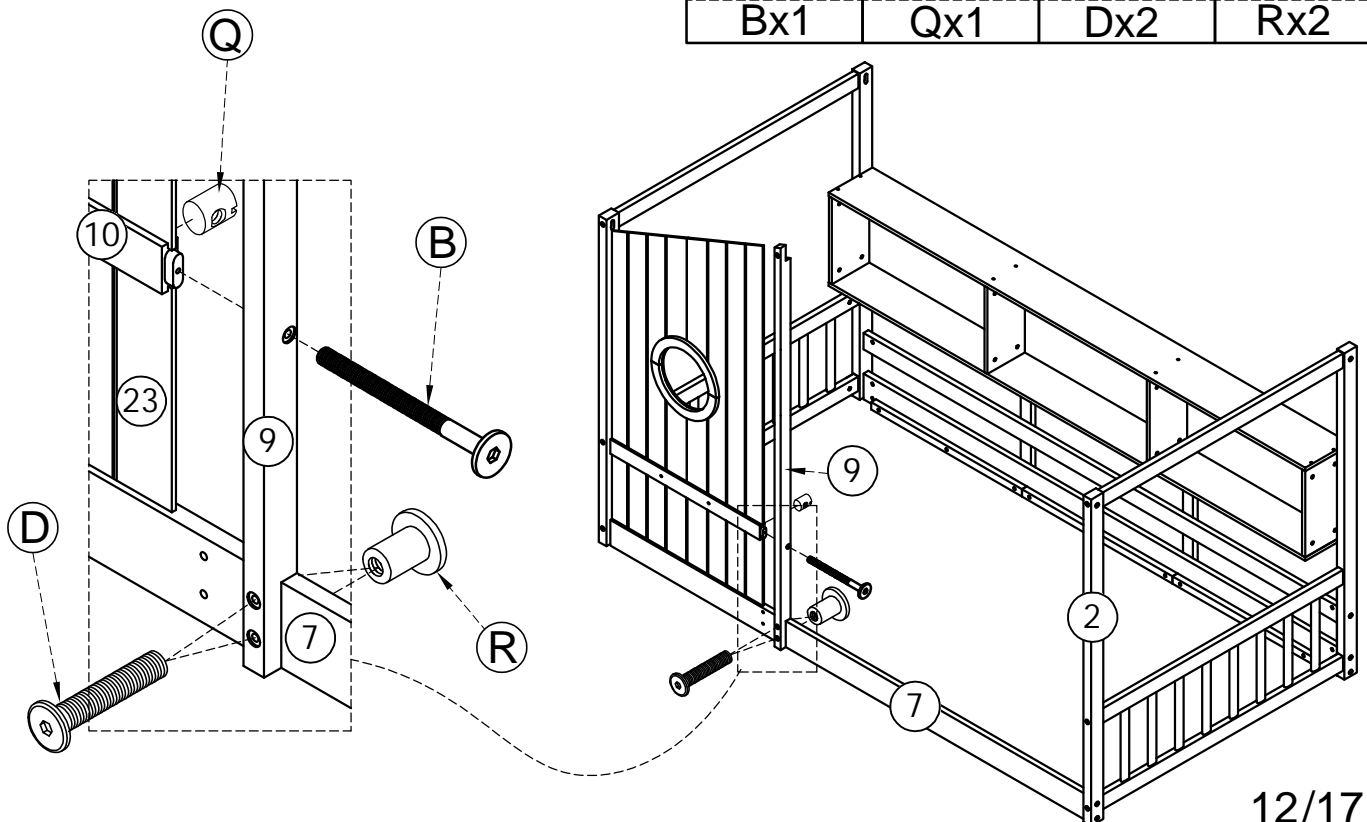

STEP 11:
Étape 11:

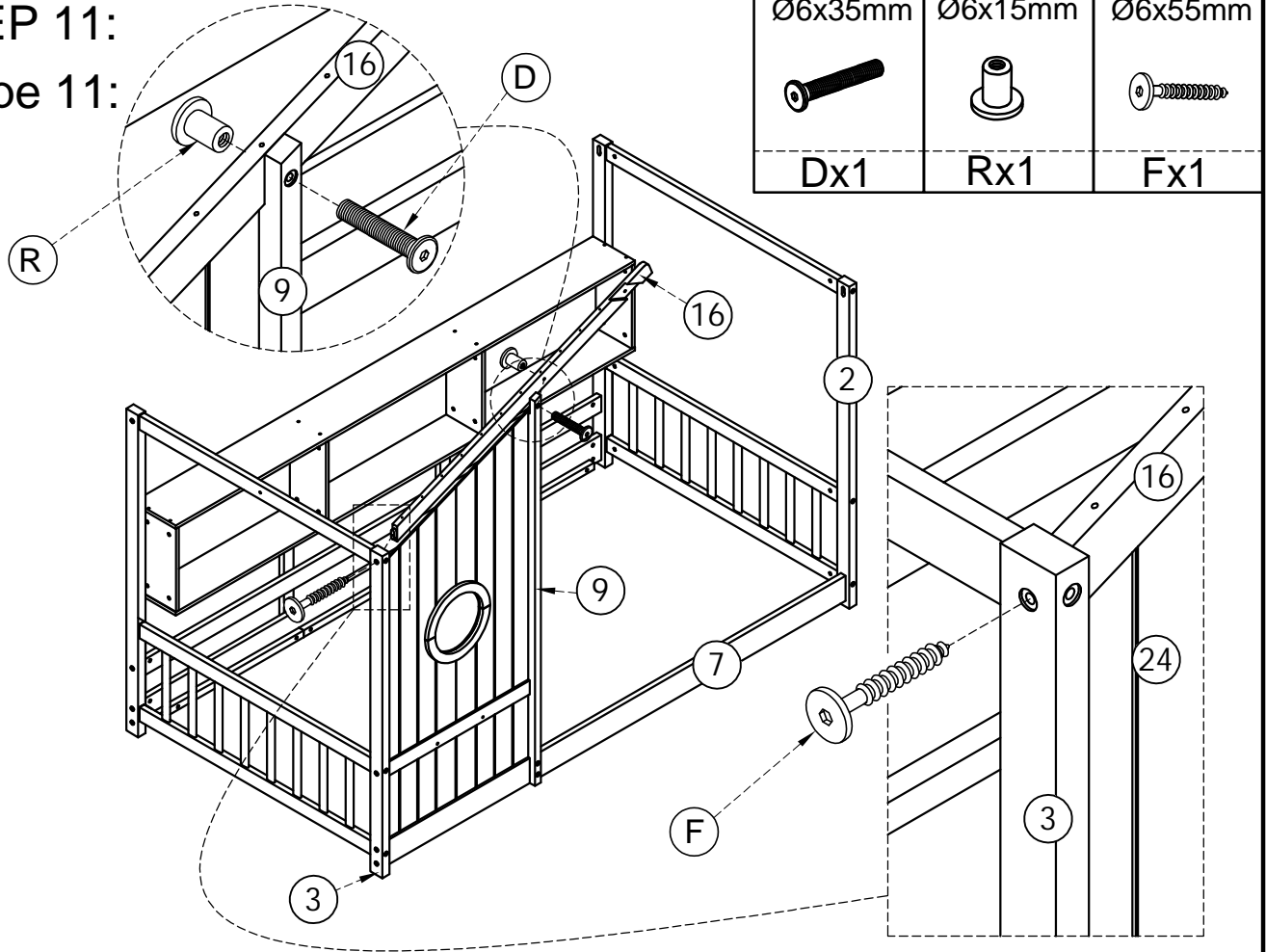

STEP 12:
Étape 12:

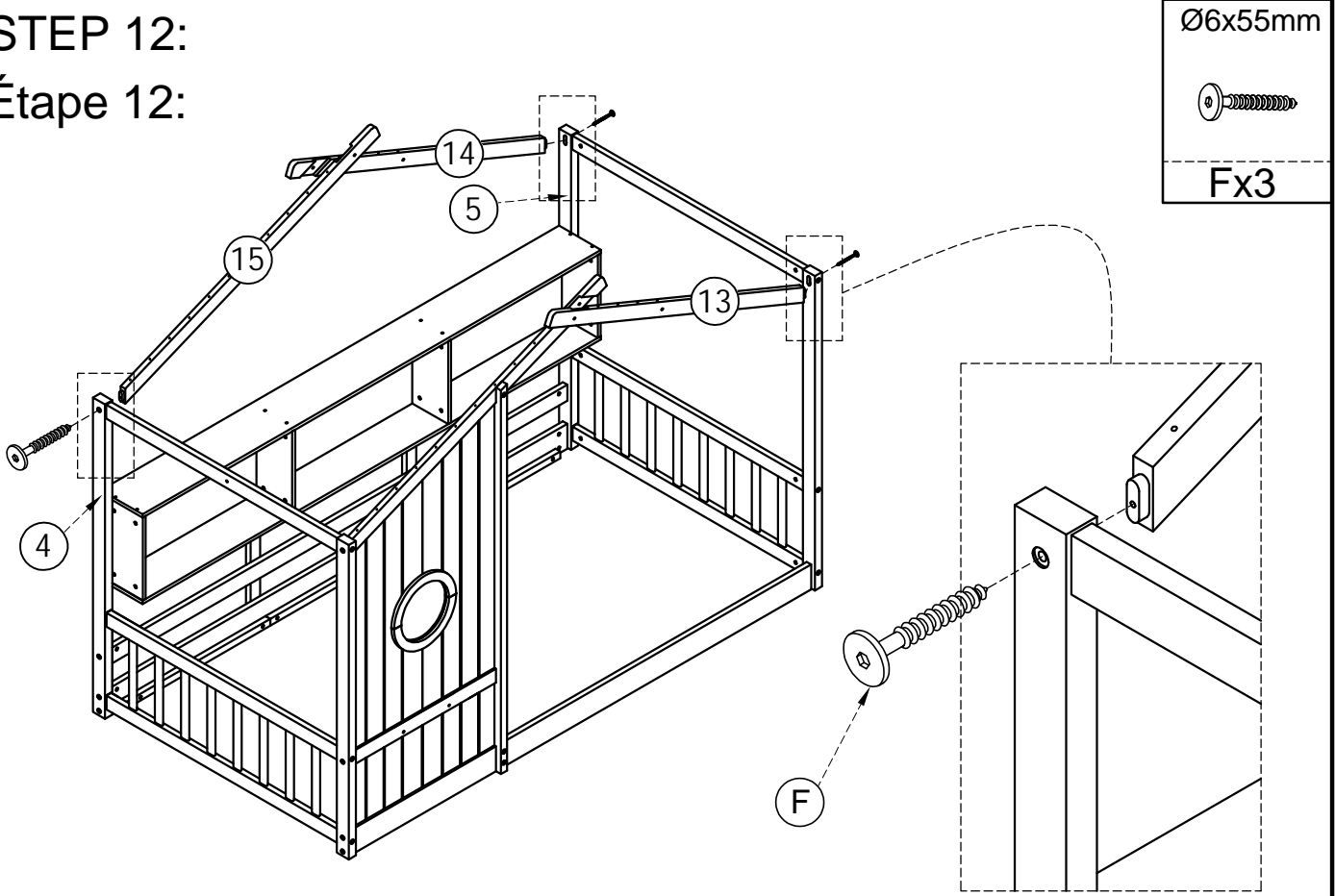

STEP 13:

Étape 13:

D4 > D3.

Ø6x60mm

Ø6x13mm

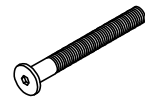

Cx4

Qx4

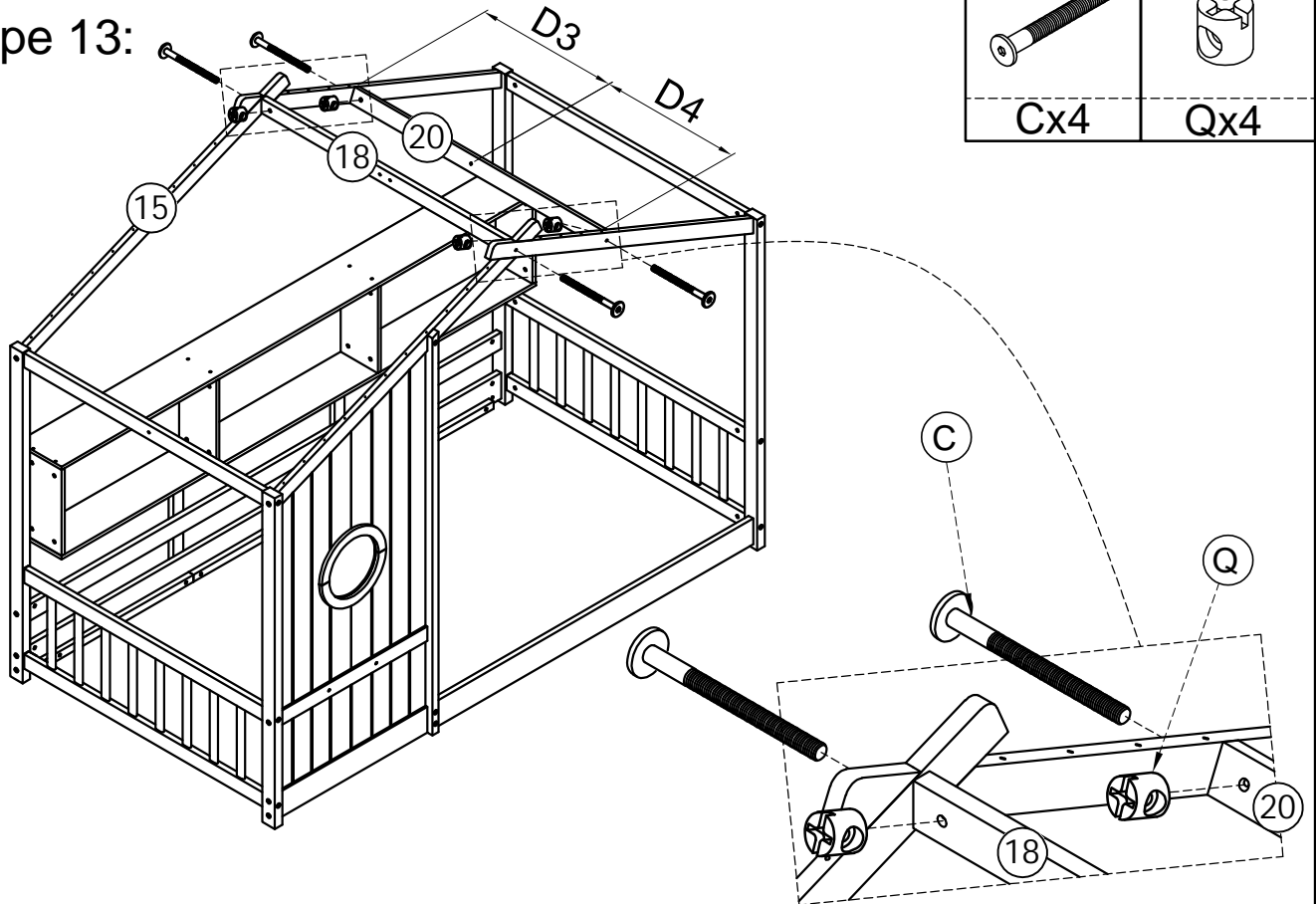

STEP 14:

Étape 14:

Ø6x55mm



Fx4

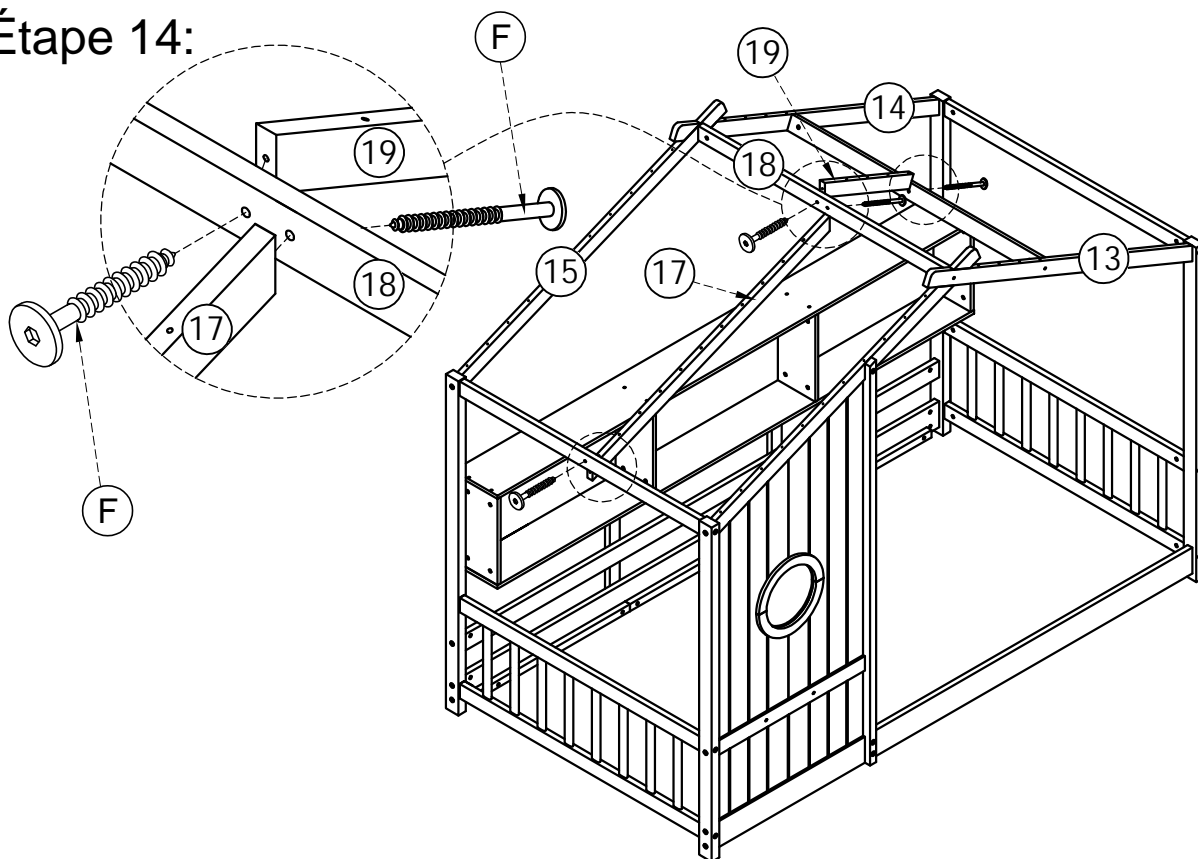

STEP 15:
Étape 15:

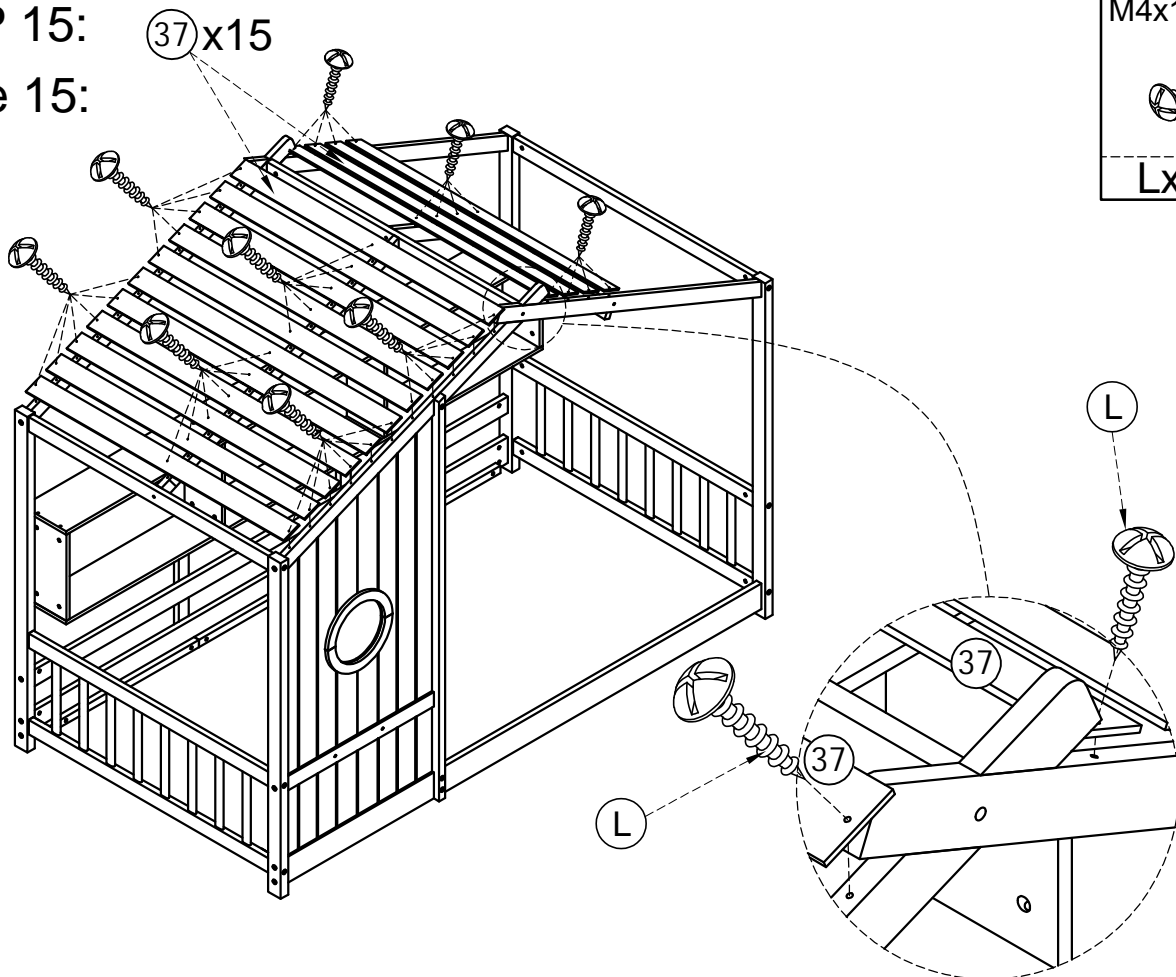

M4x15 mm
Lx45

STEP 16-1:
Étape 16-1:

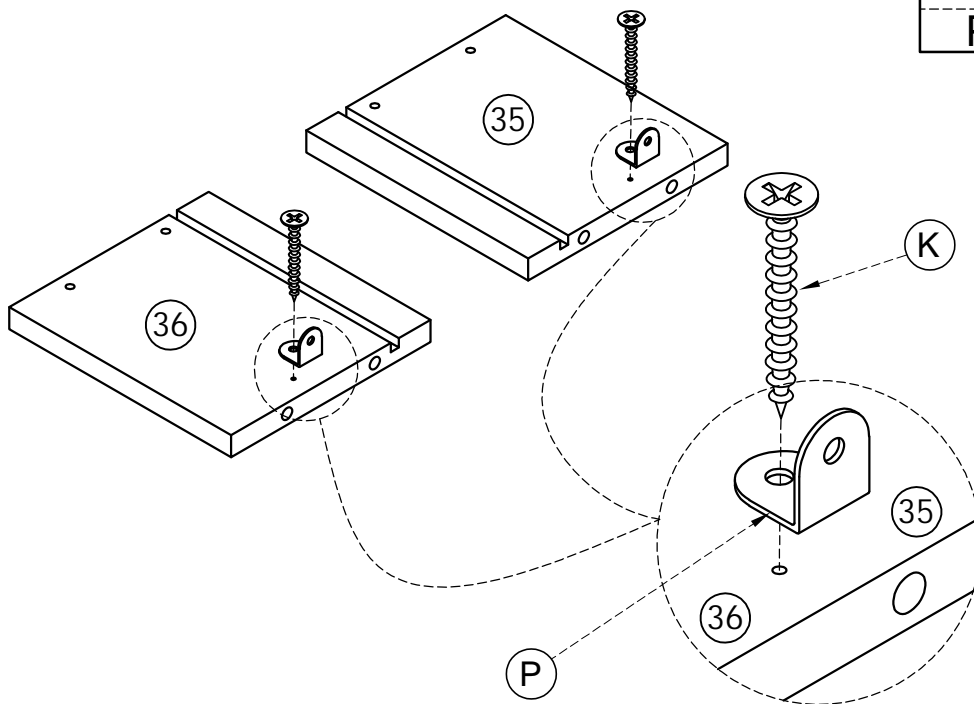

M3.5x12mm
Px2 Kx2

STEP 16-2:
Étape 16-2:

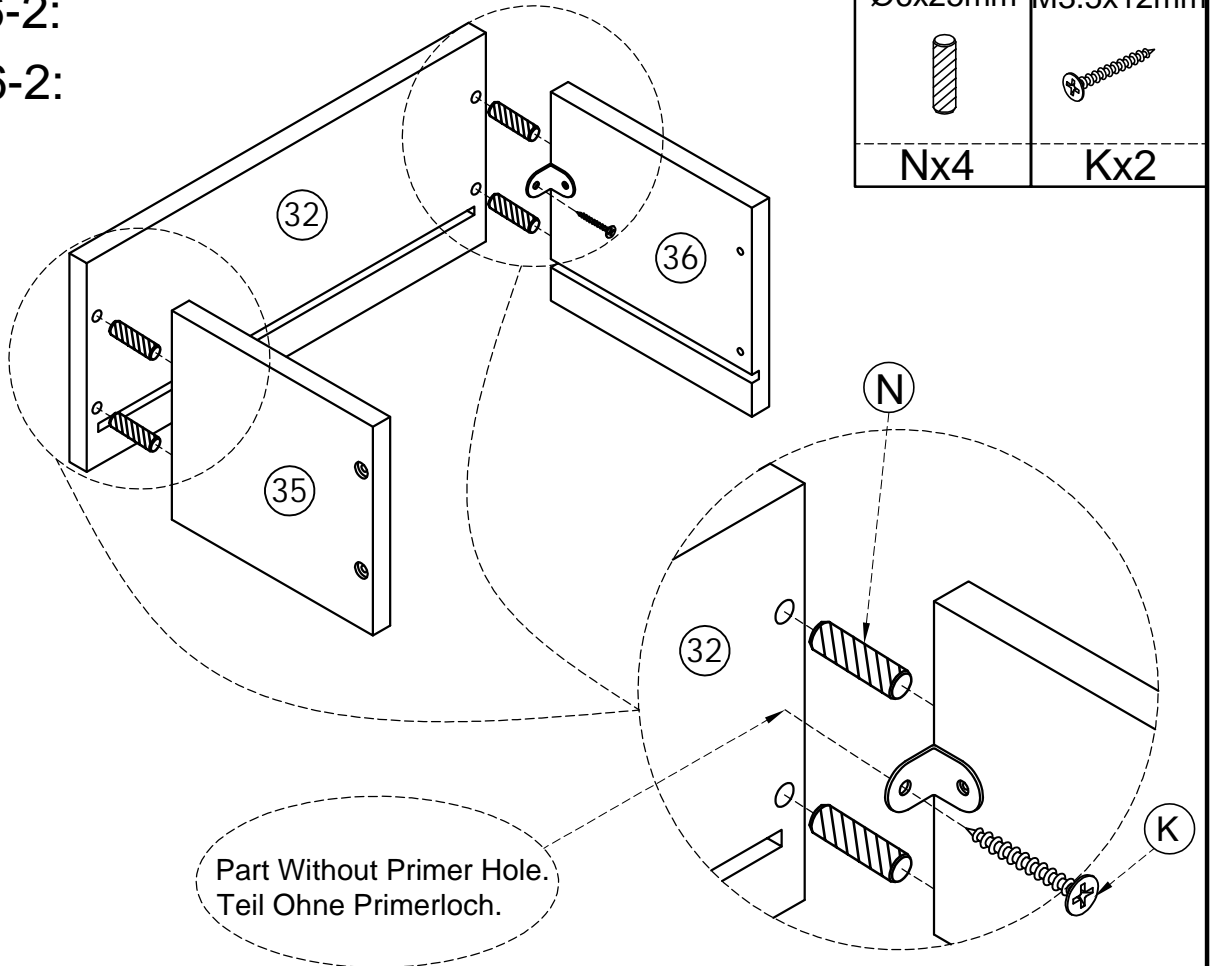

STEP 16-3:
Étape 16-3:

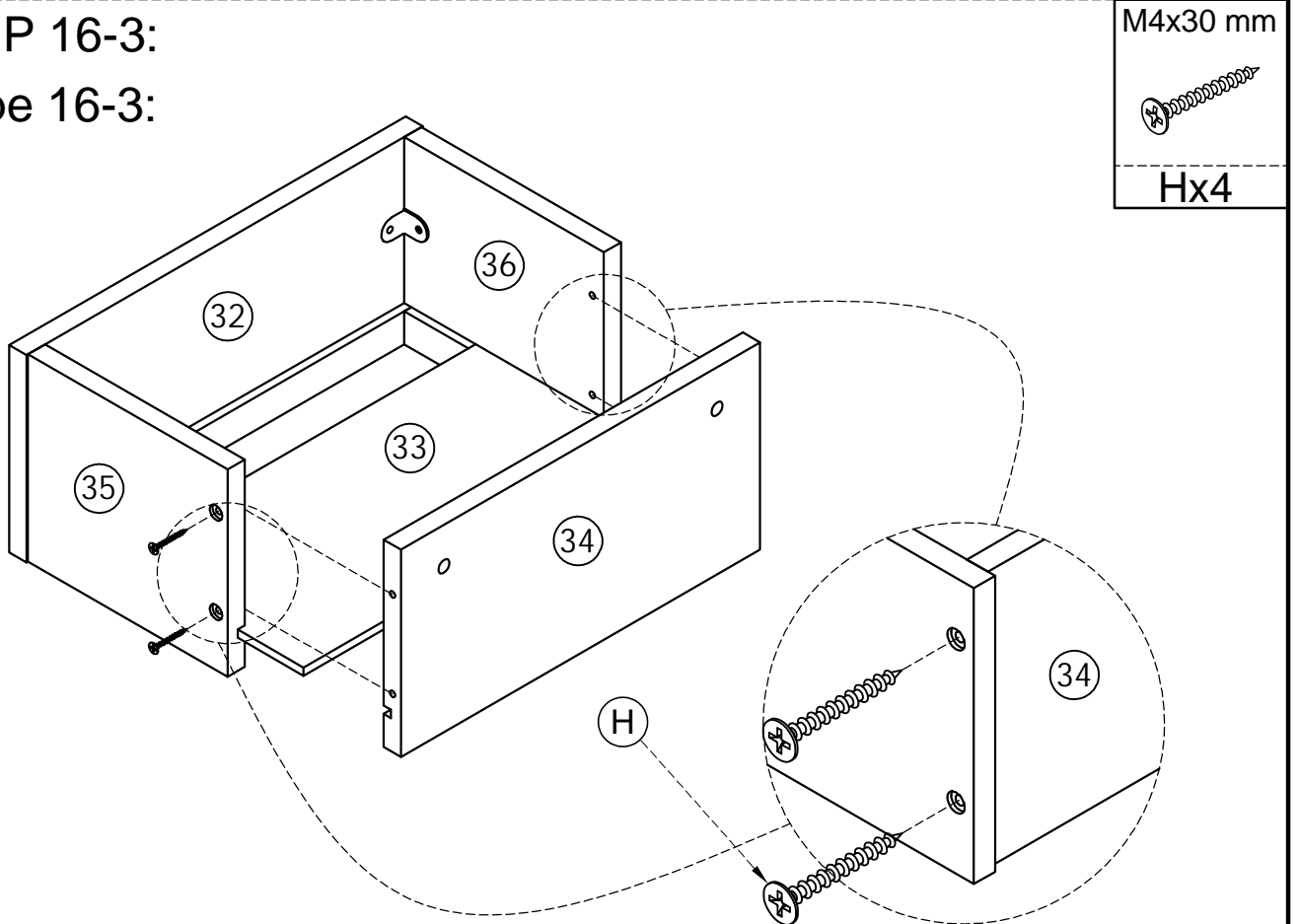

STEP 17:

Étape 17:

Ø6x20mm

Ø6x15mm



Ex2

Rx2

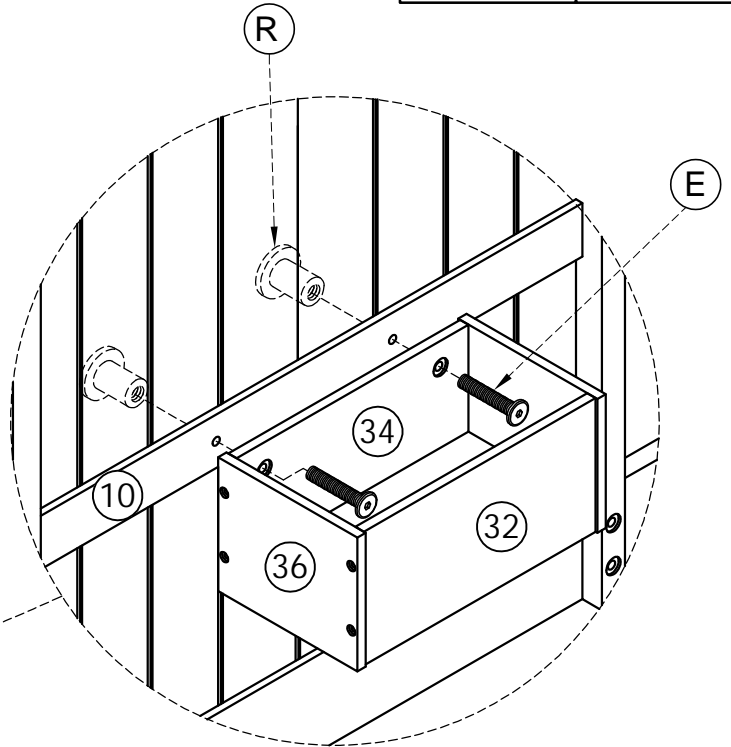
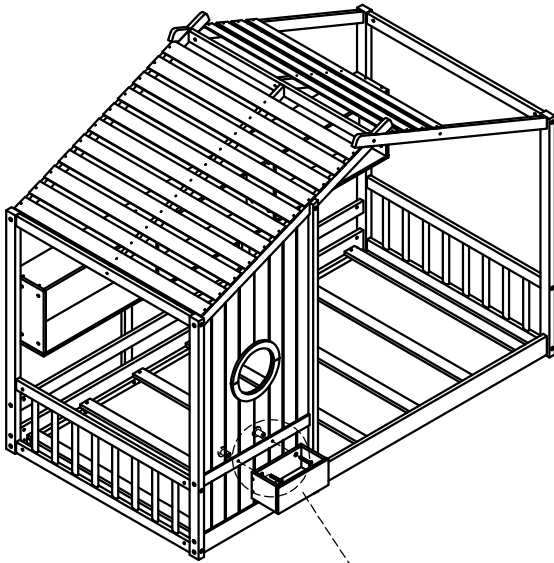

STEP 18:

Étape 18:

M4x30 mm

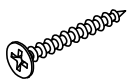

Hx14

