

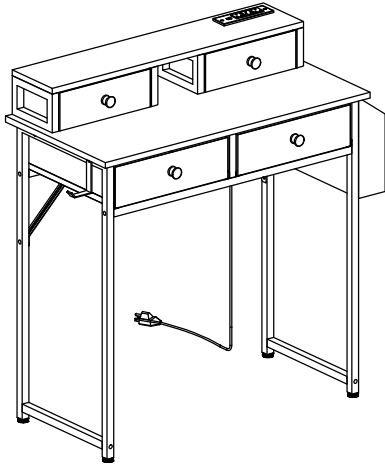









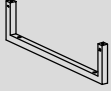

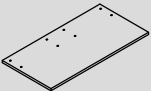



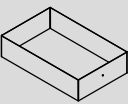
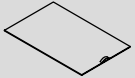

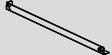
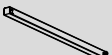

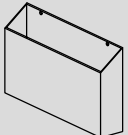
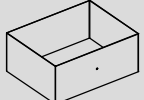
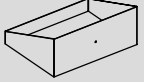



Important:



1. It's recommended to have two people for the installation, this will significantly improve your efficiency.
2. Before you begin: lay out all of the parts on a non-abrasive surface to identify the number tags in the manual and count before assembly. Please use the screws correctly to avoid popping the desk panel.
3. For a smooth assembly process, we suggest you keep a lite tightness for all the screws during assembly. After the whole desk is assembled, firmly tighten all the screws.

①  x2	②  x1	③  x1 L	④  x1 R	⑤  x1	⑥  x1	⑦  x4
⑧  With 1 hole x1	⑨  With 3 holes x1	⑩  x2	⑪  x2	⑫  x2	⑬  x2 L	⑭  x2 R
⑮  x2	⑯  x1	⑰  x1	⑱  x1	⑲  x2		
Ⓐ  M6x40 x10	Ⓑ  Desktop Lock Specialized M6x28 x14	Ⓒ  M6x20 x8	Ⓓ  M6x12 x8	Ⓔ  M6 x4	Ⓕ  Ø4x12 x2	Ⓖ  Ø25xM6x15 x4
Ⓕ  M4x10 x4	Ⓖ  x4	Ⓙ  x2	Ⓚ  S4 x1	Ⓛ  S4 x1		

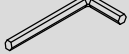
Thank you for choosing our product.

Feel free to contact us in case of any problem regarding assembling or the product itself. Our Customer Service organization can answer most concerns and can assist you with any questions you may have about your product.

Your satisfaction is our highest pursuit.

Assembly Instruction

1

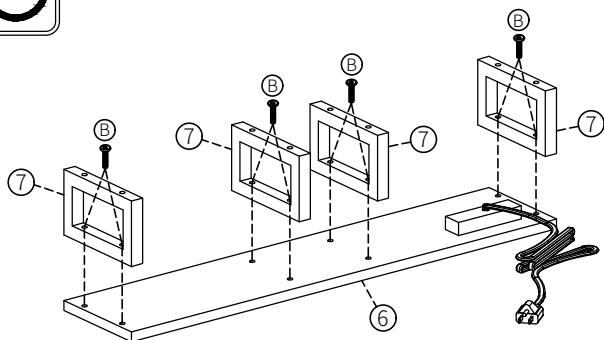
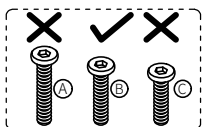
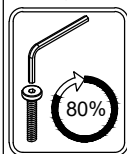

- ⑥ x 1
- ⑦ x 4
- Ⓑ x 8

2

Tighten all the screws from STEP 1 TO STEP 2.

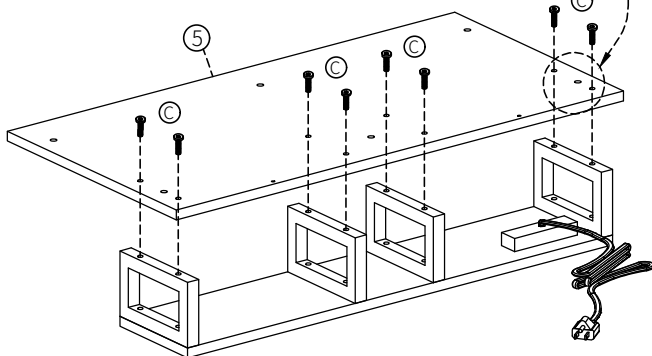
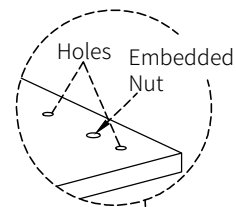
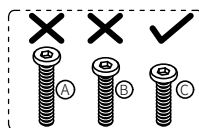
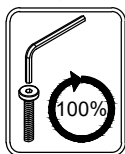

- ⑤ x 1
- Ⓒ x 8

3

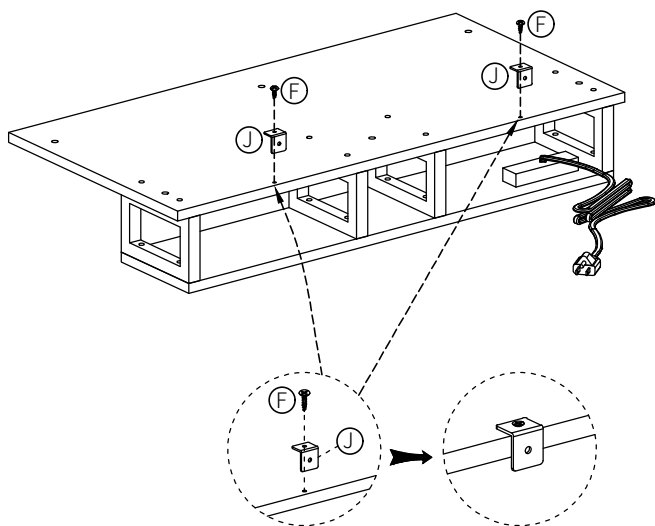

- Ⓕ x 2
- Ⓖ x 2

4

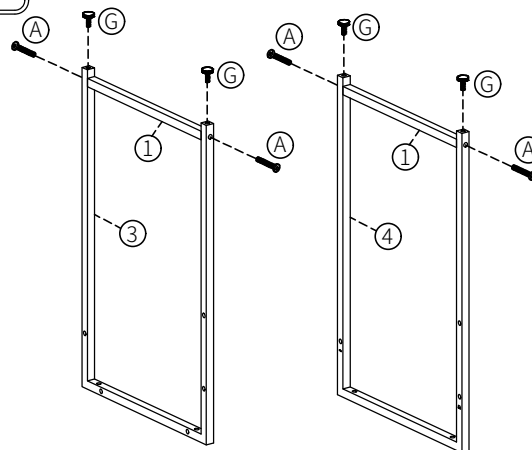
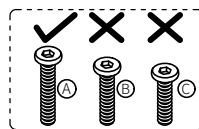
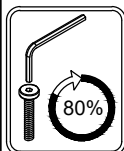

- ① x 2
- ③ x 1
- ④ x 1
- Ⓐ x 4
- Ⓒ x 4

5

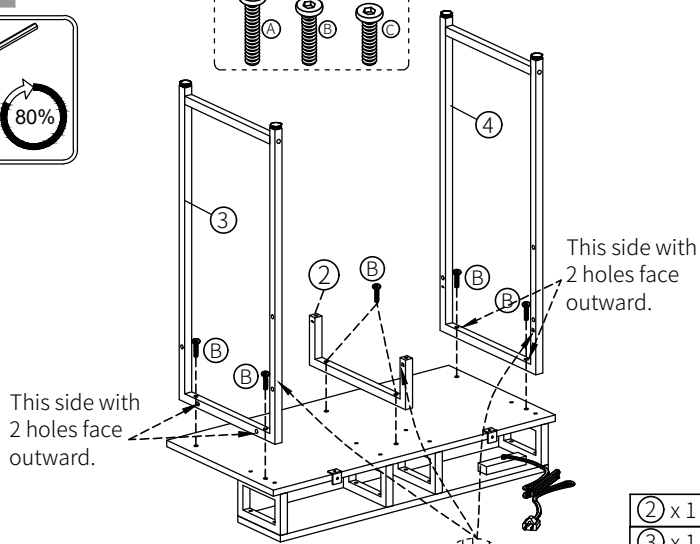
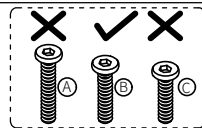
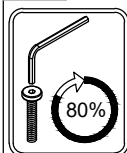

- ② x 1
- ③ x 1
- ④ x 1
- Ⓑ x 6

Square holes of part 2/3/4 on the same side.

6

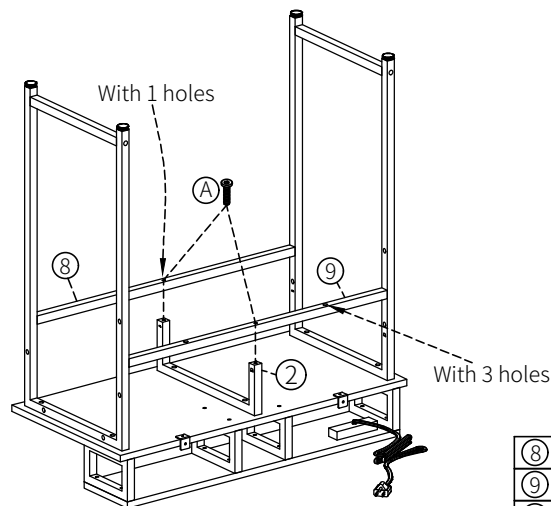
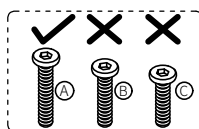
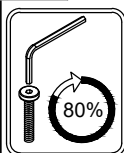

- ⑧ x 1
- ⑨ x 1
- Ⓐ x 2

Assembly Instruction

7

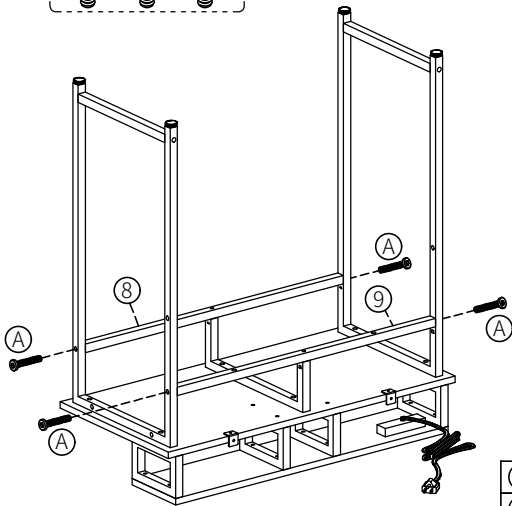
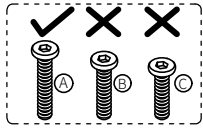
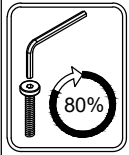

⑧ x 1
⑨ x 1
Ⓐ x 4

8

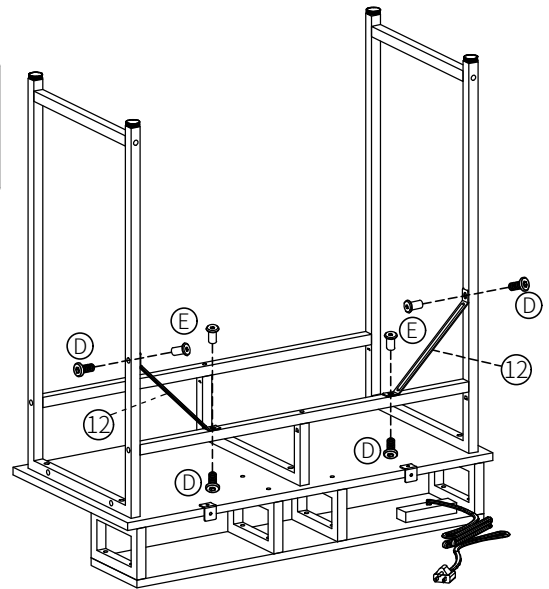
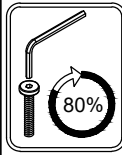

⑫ x 2
Ⓓ x 4
Ⓔ x 4

9

Step 9-1: The screw Ⓐ should be loosened and the position of part ⑧ should be adjusted if the front of ⑬ or ⑭ cannot be inserted. Once both ⑬ and ⑭ are fully inserted, tighten all the screw Ⓐ.

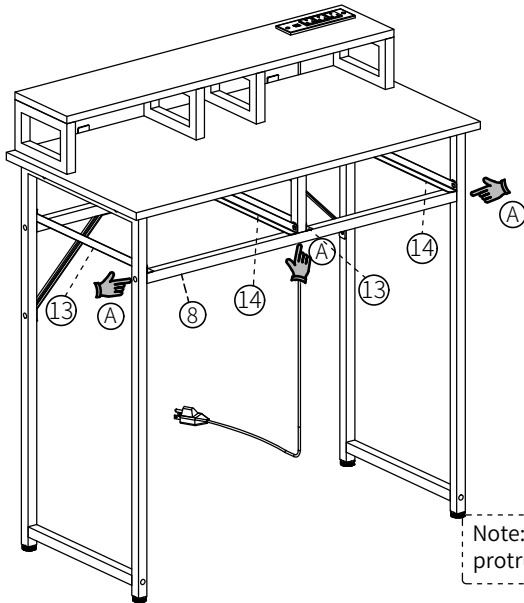

Step 9-2:

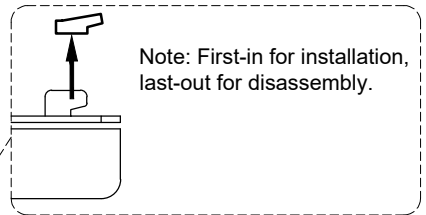
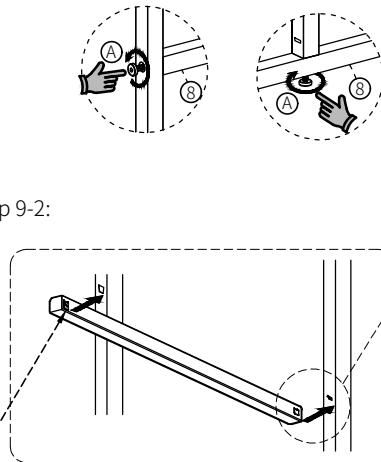

Note: If the metal tab is not protruding, pry it open slightly.

⑬ x 2
⑭ x 2

10

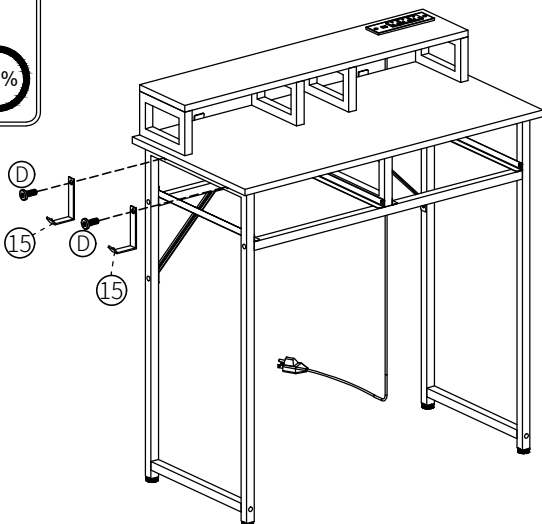
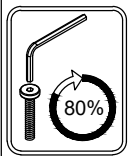

⑮ x 2
Ⓓ x 2

11

Tighten all the screws from STEP 3 TO STEP 11.

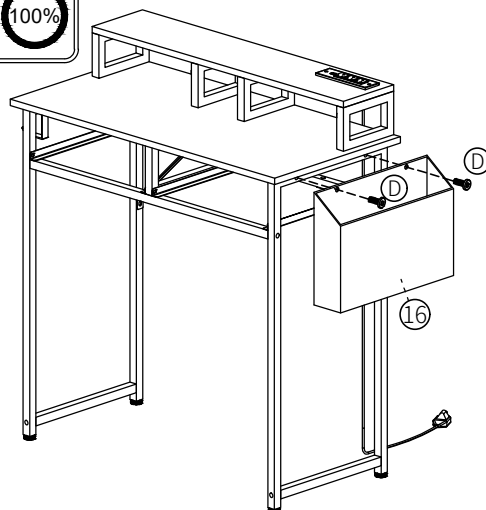
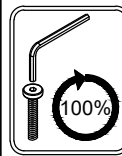

⑯ x 1
Ⓓ x 2

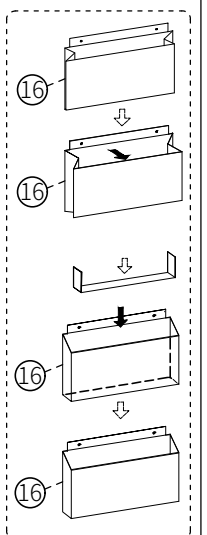

Assembly Instruction

12

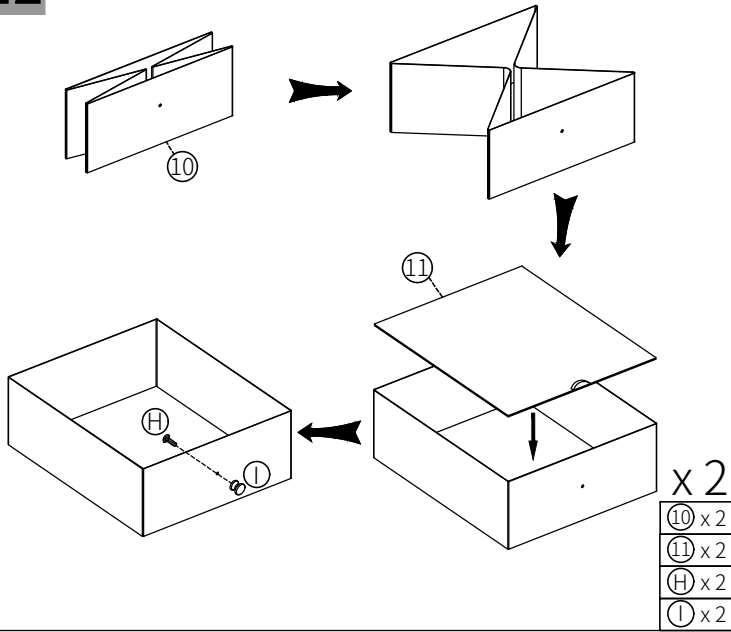

13

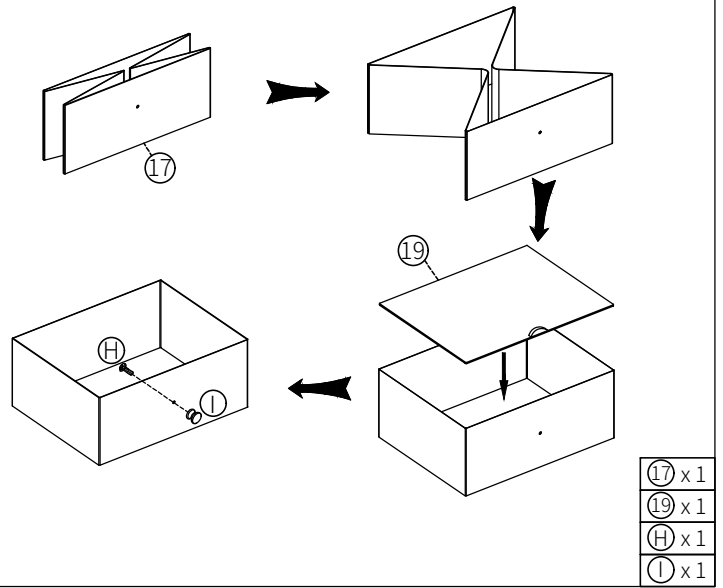

14

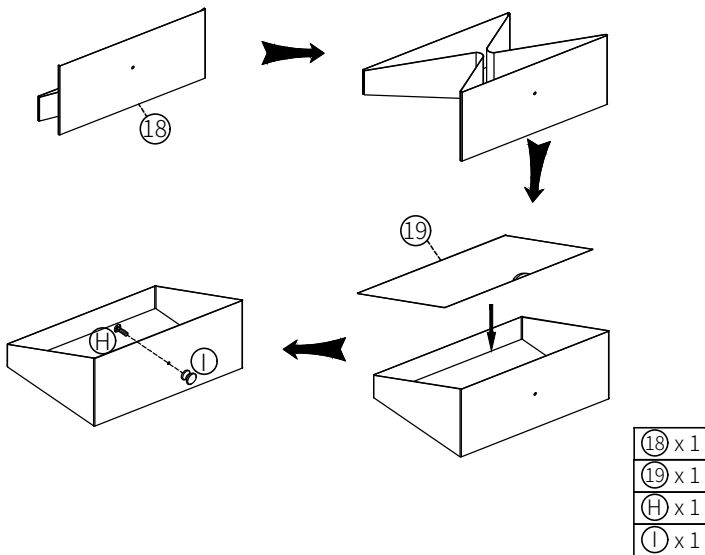

15

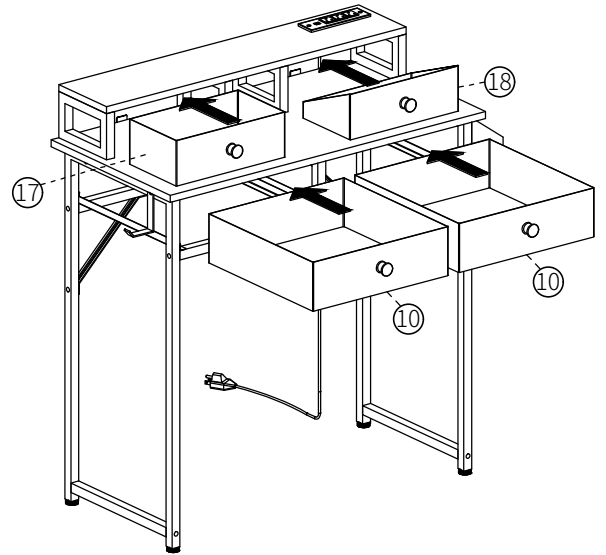

16

