

DAVOS 140

PL> INSTRUKCJA MONTAŻU
D >MONTAGEANLEITUNG
GB>ASSEMBLY INSTRUCTIONS
NL>HANDLEIDING VOOR DE MONTAGE
F >MODEL D'EMPLOI
CZ> POKYNY PRO INSTALACI
SK> INSTRUKCJA MONTAŽUNÁVOD

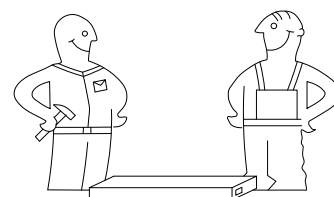

NA INŠTALÁCIU
HR> UPUTE ZA MONTAŽU
SRB> УПУТСТВО ЗА УГРАДЊУ



180 minut
180 minuten
180 minutes
180 minuten
180 minutes

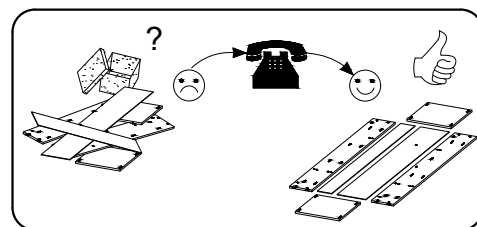
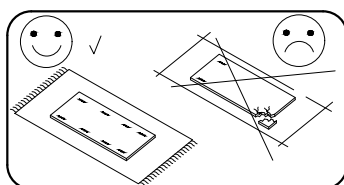
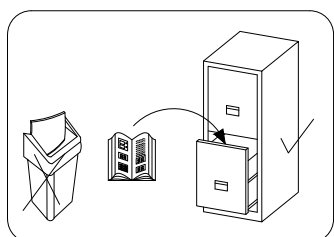
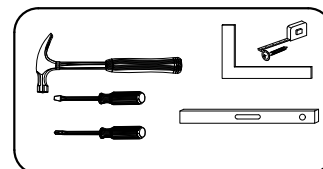

**Uwaga / Achtung / Caution / Opgelet / Attention /
Pozornost / Pozornost' / Pažnja / Пажња**



PL>Czyszczenie należy wykonać wyłącznie za pomocą ściereczki lub lekko nawilżonego ręcznika.
Nie stosować środków czyszczących do szorowania.

Szanowny kliencie, jeśli podczas montażu stwierdzisz uszkodzenie lub brak części, proszę podaj jej kod alfanumeryczny lub zaznacz ją na instrukcji montażu i prześlij wraz z protokołem reklamacyjnym

D >Bitte nur mit einem Staubtuch oder leicht feuchtem Lappen reinigen. Keine scheuerenden Putzmittel verwenden.

Sehr geehrter Kunde, sollte ein Teil fehlen oder beschädigt sein, kreuzen Sie dies bitte deutlich auf der Montageanleitung an und schicken Sie die Montageanleitung mit ein.

GB>Please only clean with a duster or a damp cloth. Do not use any abrasive cleaners.

Dear customer, should there be any piece missing or damaged, kindly mark this piece clearly on the attached assembly instructions and return them to us.

NL>Reinig alleen met een stofdoek of een lichtjes vochtige doek. Gebruik geen schurende poetsmiddelen.

Geachte klant, in het geval van beschadiging of ontbrekende onderdelen tijdens de montage, gelieve de alfanumerieke code in de montagehandleiding te vermelden of te markeren en samen met het klachtenprotocol mee te sturen

F >Le nettoyage se fait uniquement à l'aide d'un torchon ou d'une serviette légèrement mouillée.

Cher client, en cas de dommages ou de pièces manquantes lors du montage, veuillez fournir ou marquer le code alphanumérique dans le manuel de montage et l'envoyer avec le protocole de réclamation

CZ>Čištění by mělo být prováděno pouze hadříkem nebo mírně navlhčeným hadříkem.
Nepoužívejte abrazivní čisticí prostředky.

Vážený zákazníku, pokud při montáži zjistíte poškozený nebo chybějící díl, uveďte jeho alfanumerický kód nebo jej označte v montážním návodu a zašlete spolu s reklamačním protokolem

SK>Čistenie by sa malo vykonávať iba handričkou alebo mierne navlhčenou utierkou. Nepoužívajte čistiace prostriedky na drhnutie..

Vážený zákazník, ak pri montáži nájdete poškodený alebo chýbajúci diel, uveďte jeho alfanumerický kód alebo ho označte na montážnom návode a zašlite spolu s reklamačným protokolom

HR>Čišćenje se smije vršiti samo krpom ili blago navlaženim ručnikom. Nemojte koristiti sredstva za čišćenje.

















Poštovani kupče, ako tijekom sastavljanja nađete oštećeni dio ili dio koji nedostaje, molimo da dostavite njegov alfanumerički kod ili ga označite u priručniku za sastavljanje i pošaljite ga zajedno s protokolom reklamacije

SRB>Чишћење треба вршити само крпом или благо влажним пешкиром.Немојте користити средства за чишћење.

Поштовани купче, ако током монтаже нађете оштећен или недостаје део, наведите његов алфанумерички код или га означите у приручнику за монтажу и пошаљите га заједно са рекламационим протоколом

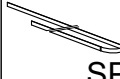
Karta serwisowa /Service Karte /Service card /Service kaart /Carte de service/ služební karta/služobný preukaz/servisna kartica/сервисна картица

AKCESORIA / ZUBEHÖR / ACCESSORIES / ACCESSOIRES / ACCESSOIRES / PŘÍSLUŠENSTVÍ / DOPLNKY / PRIBOR / ПРИБОР

 8.0x35 D	 A	 B	 X	 N	 L-870 V1	 WD	 WG	 L-1366 SG	 L-1366 SD
20	60	60	40	4	2	4	4	1	1
 S1	 L-2258 DP	 L-1360 Y	 L-2258 SP	 4.0x25 P1	 M	 3.5x16 H	 3.5x16 HC		
110	4	3	4	16	8	52	54		

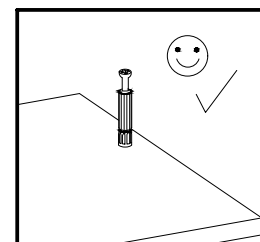
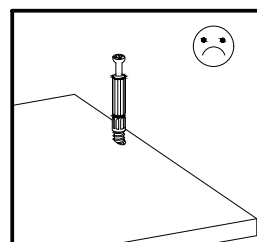
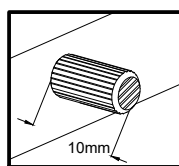
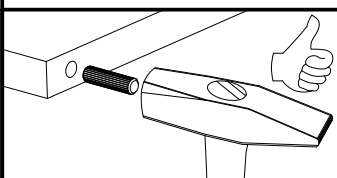
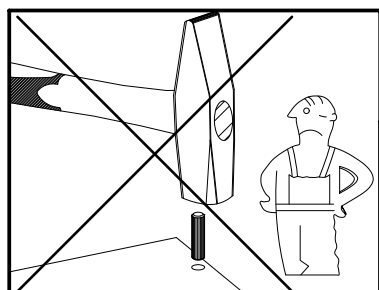
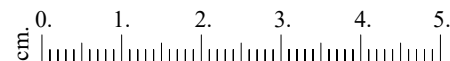

opcja 1

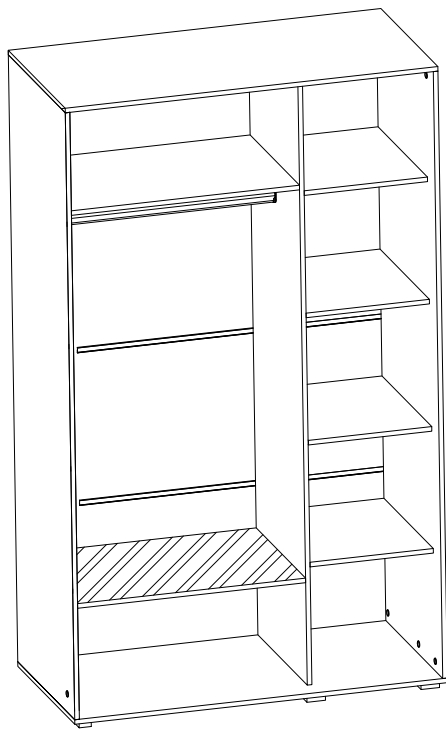

opcja 2

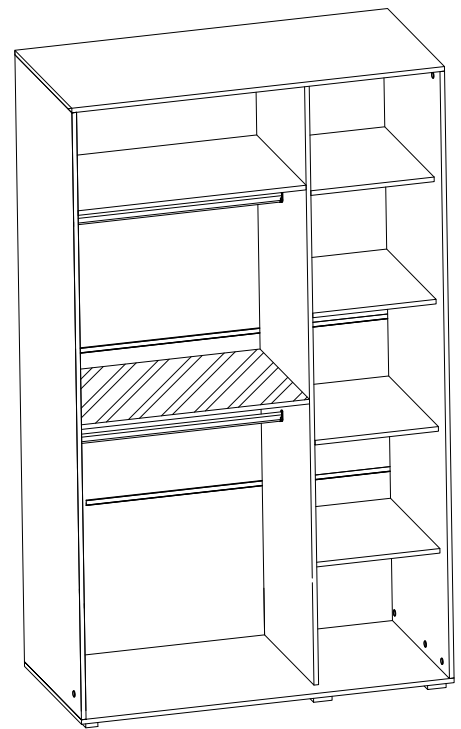

1.	1	1402	602	16
2.	1	1402	602	16
3.	1	2300	600	16
4.	1	2300	600	16
6.	1	2300	490	16
7.	4	476	480	16
8.	2	875	480	16
9.	4	1395	580	3
10.	1	2258	700	16
11.	1	2258	700	16
12.	1	2258	550	16

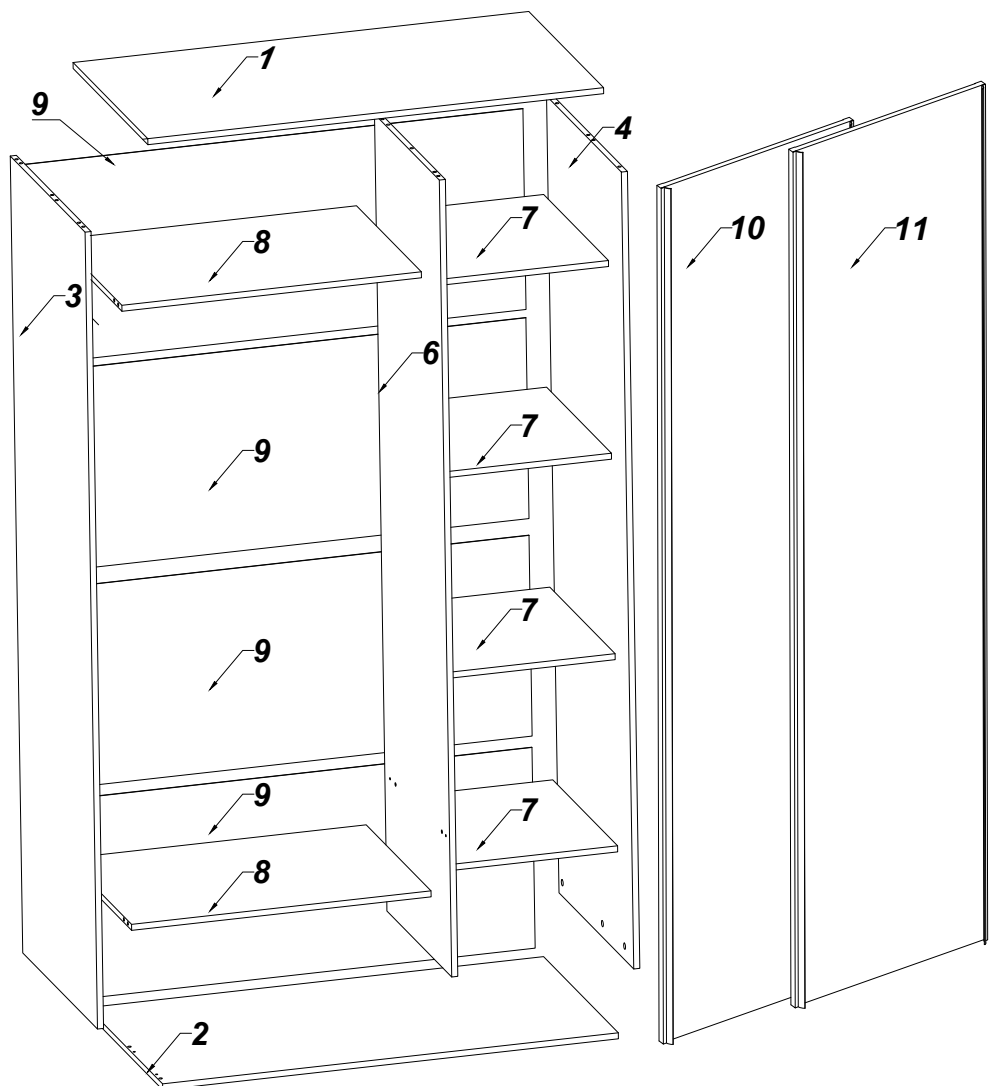

1

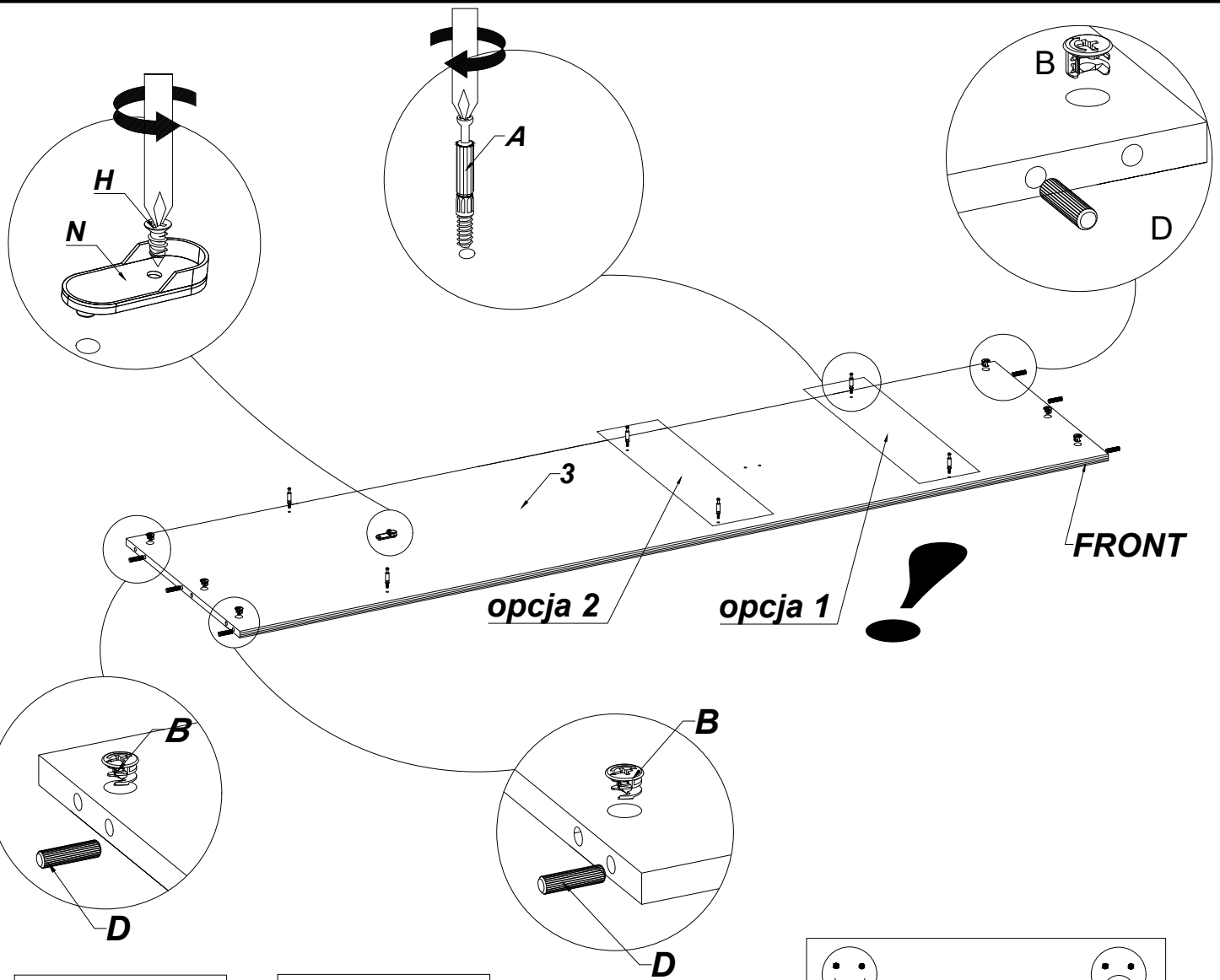

2

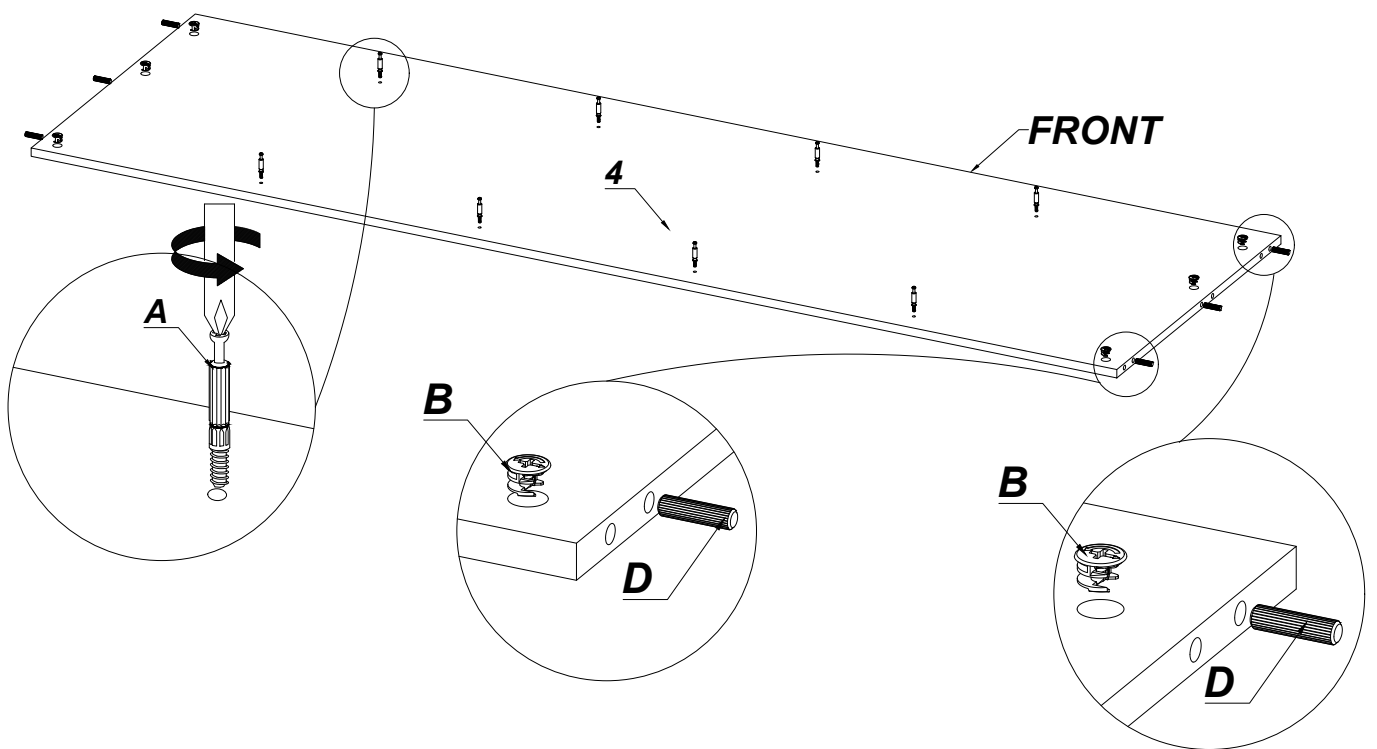
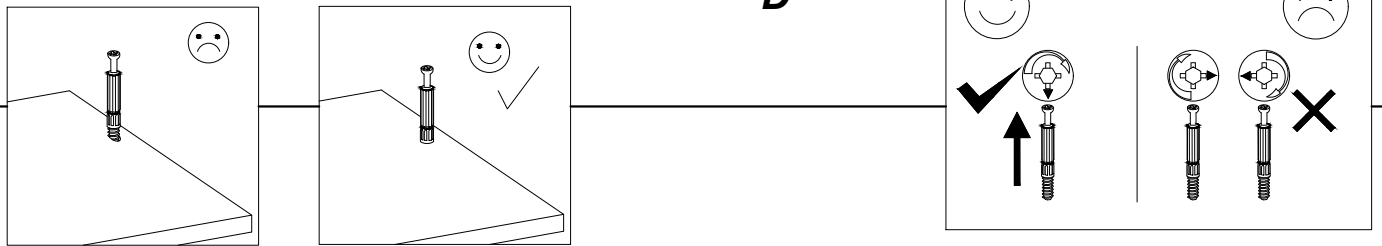

3

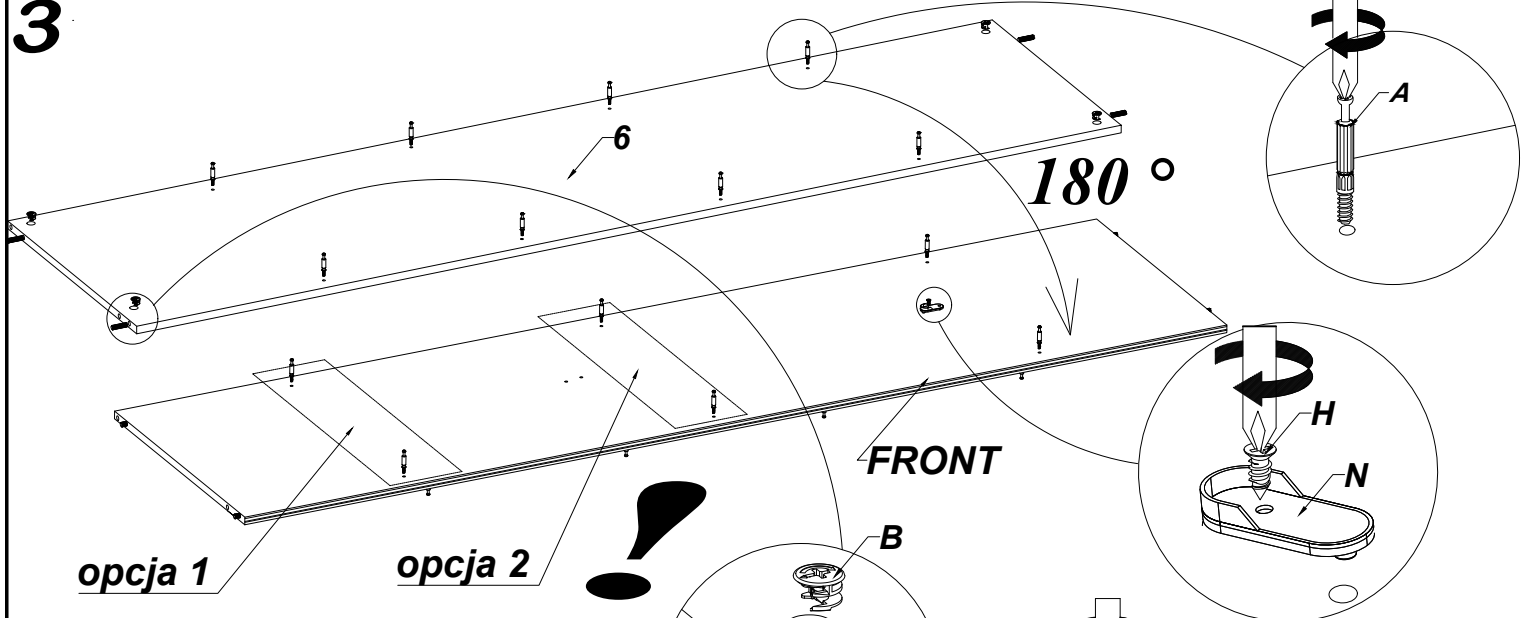

4

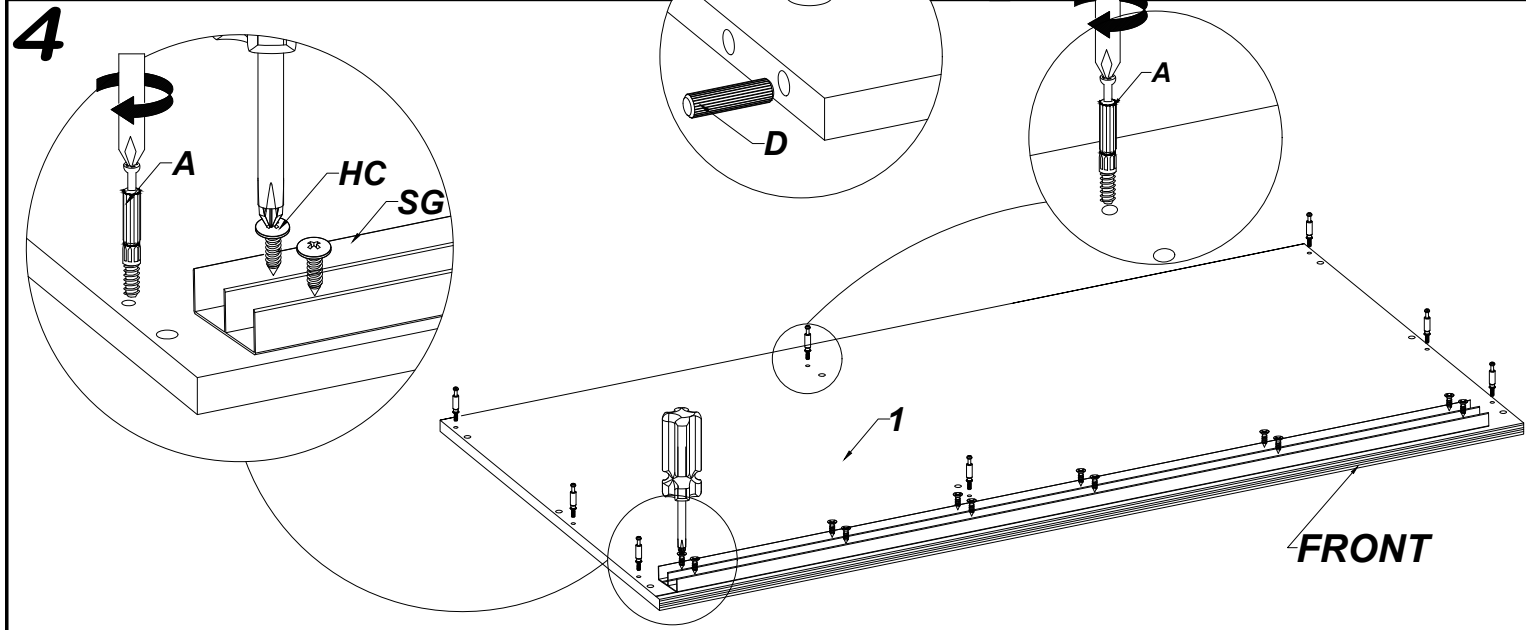

5

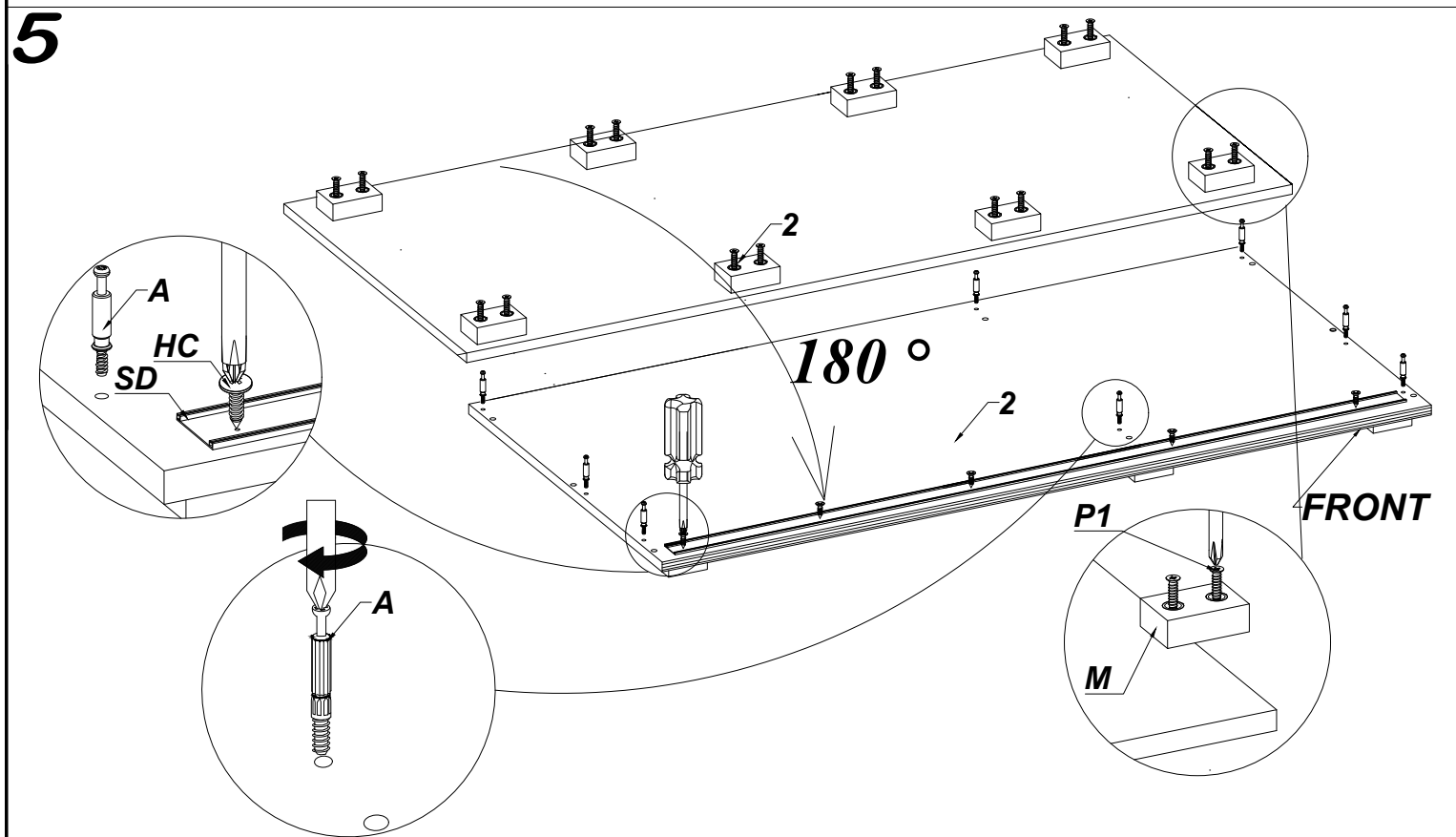

6

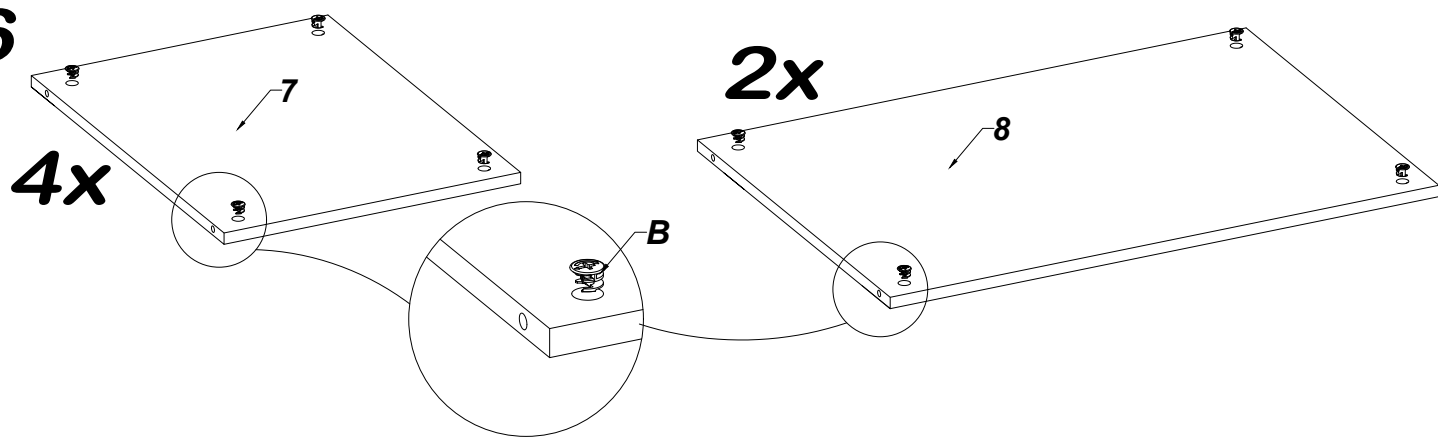

7 opcja 1

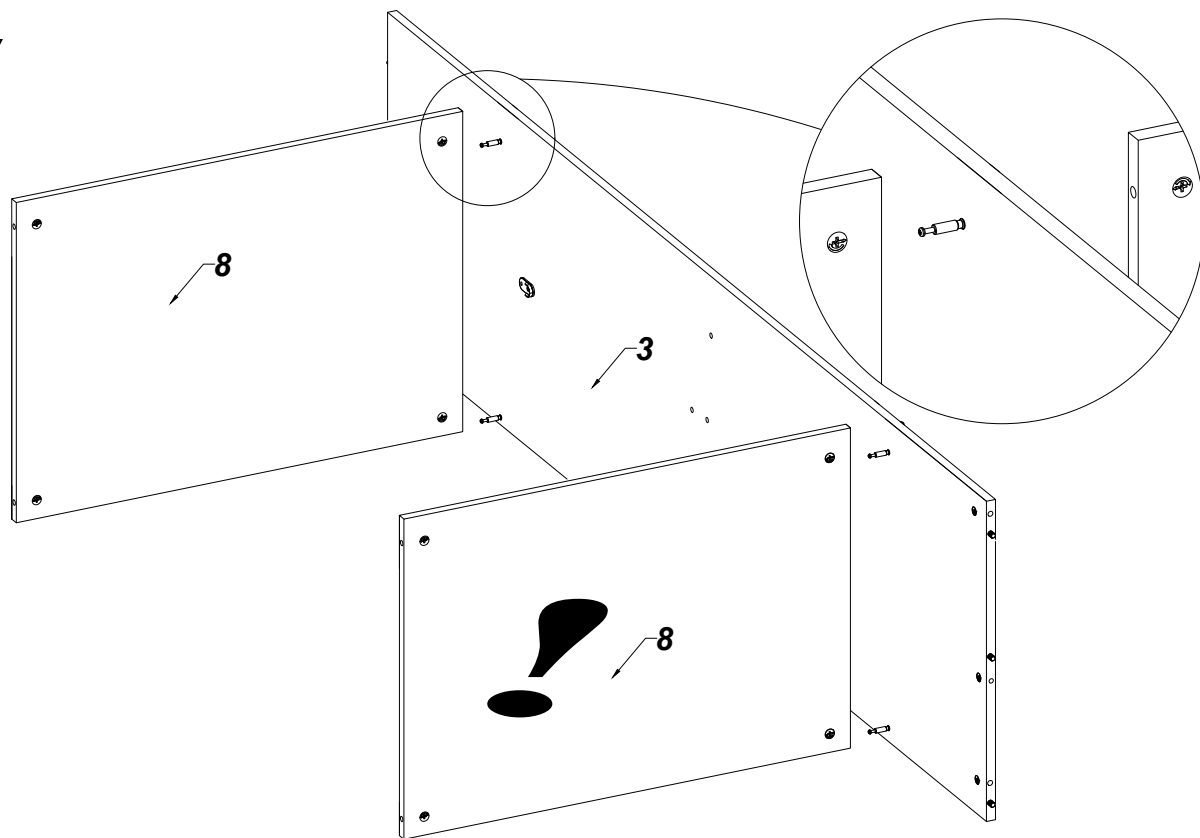

8 opcja 2

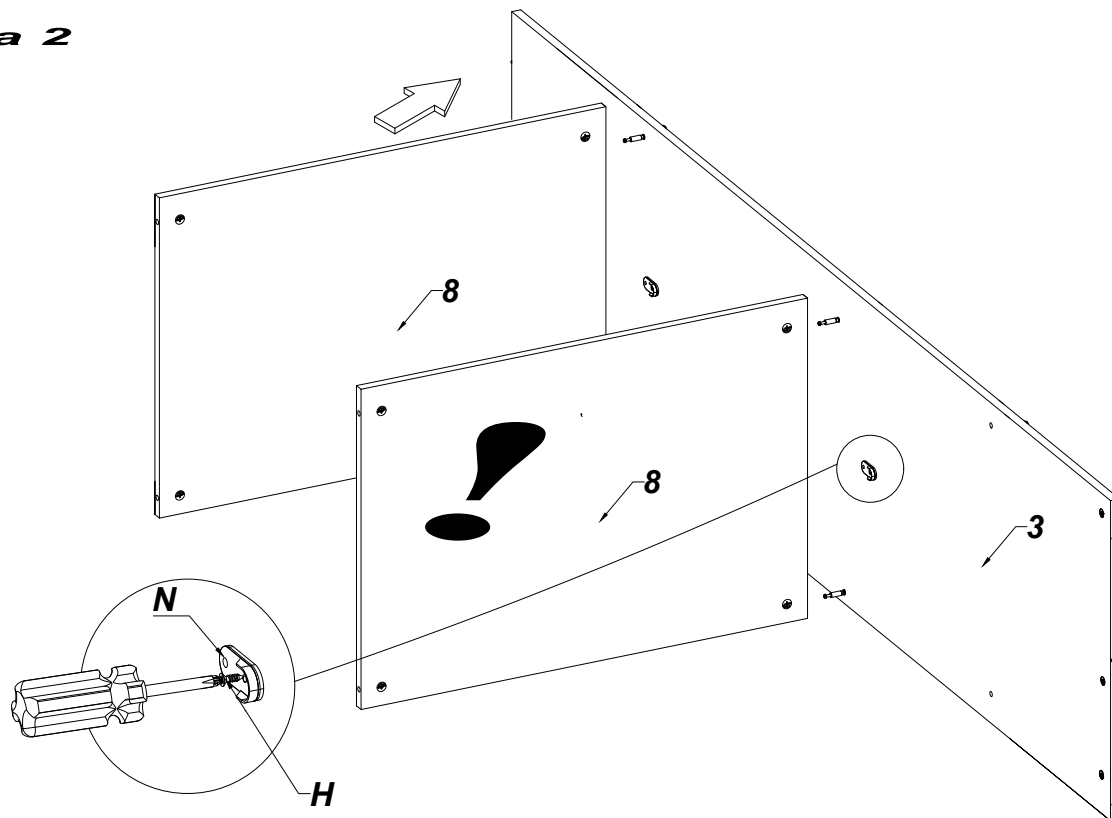

9

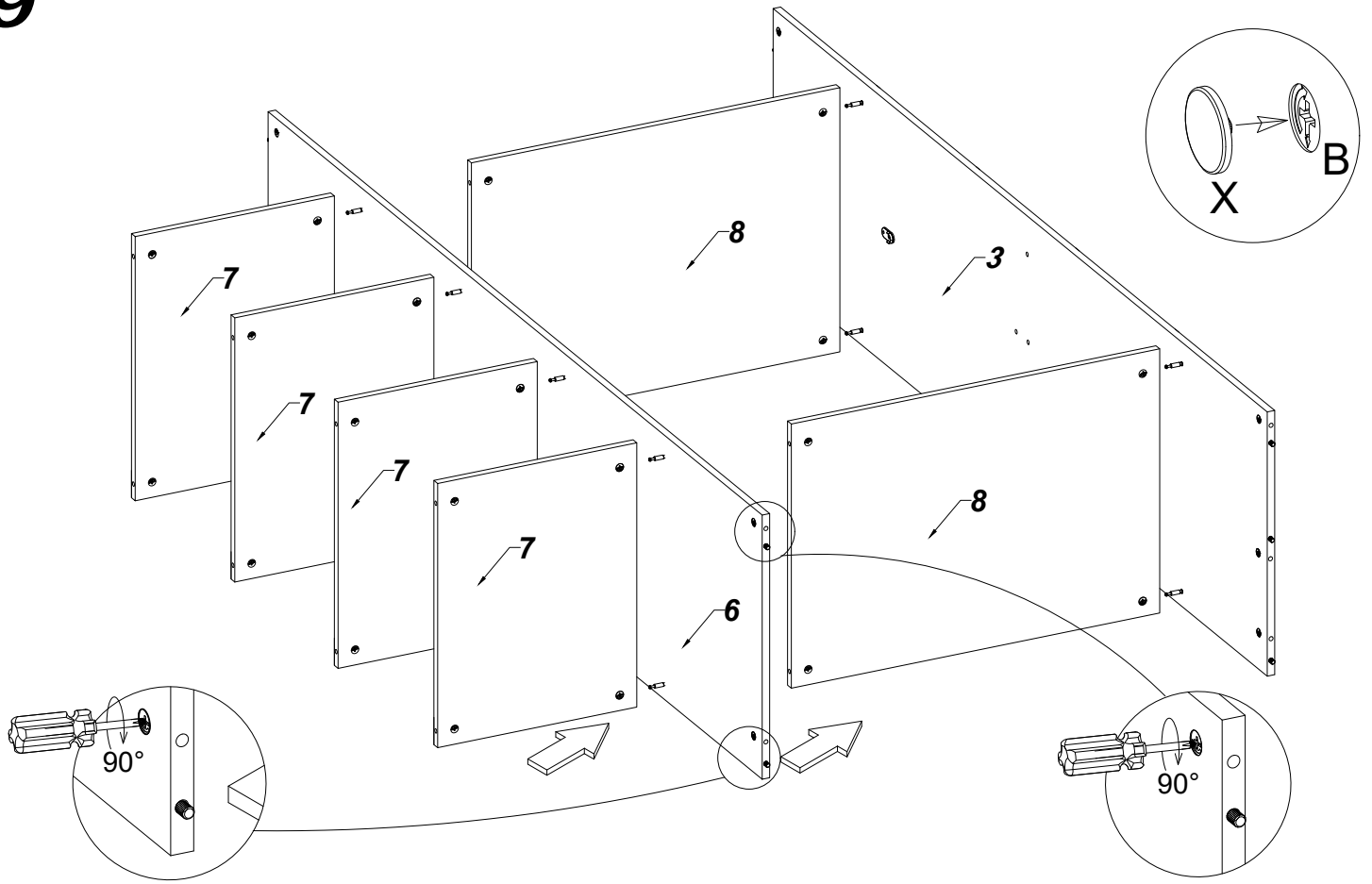

10

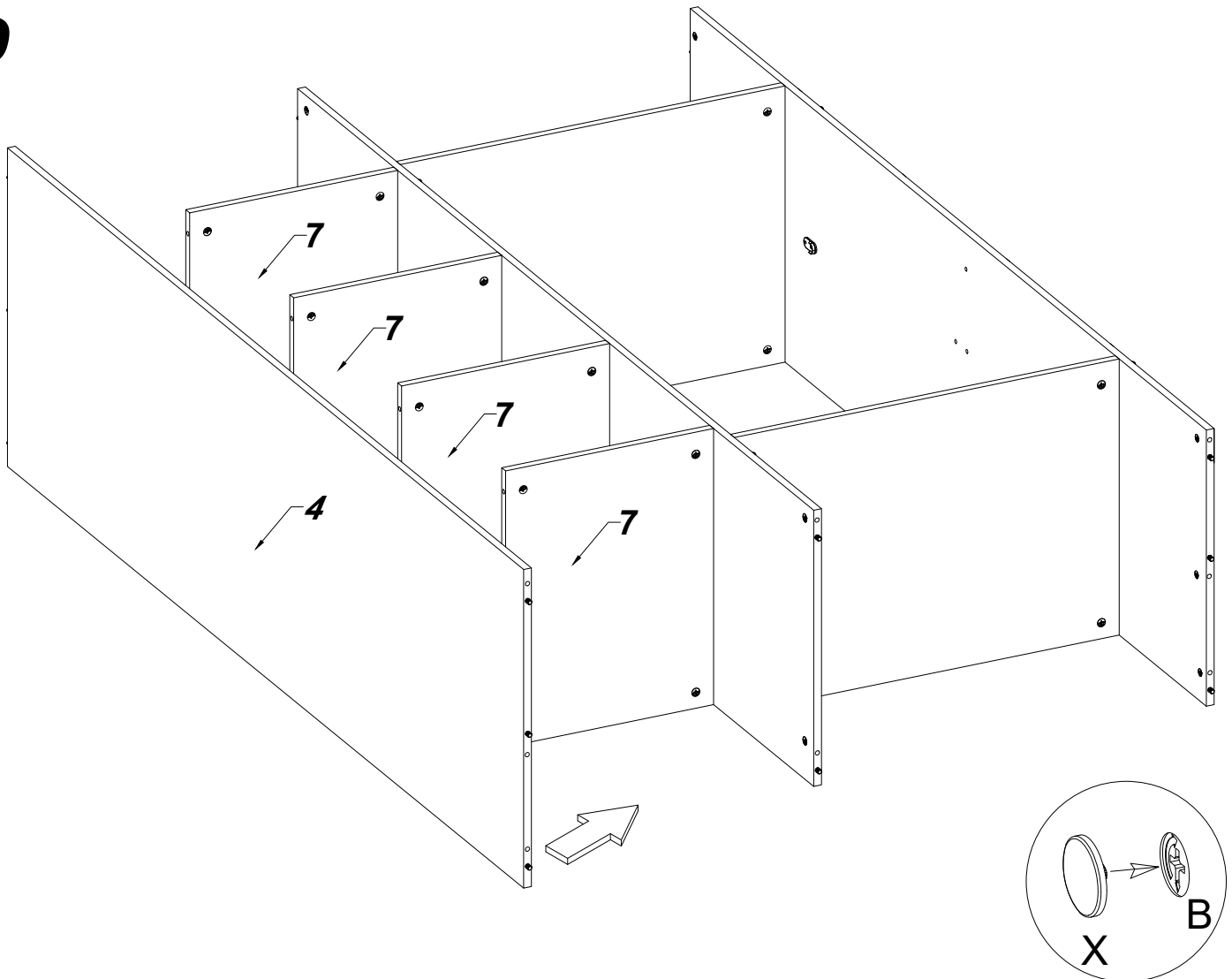

11

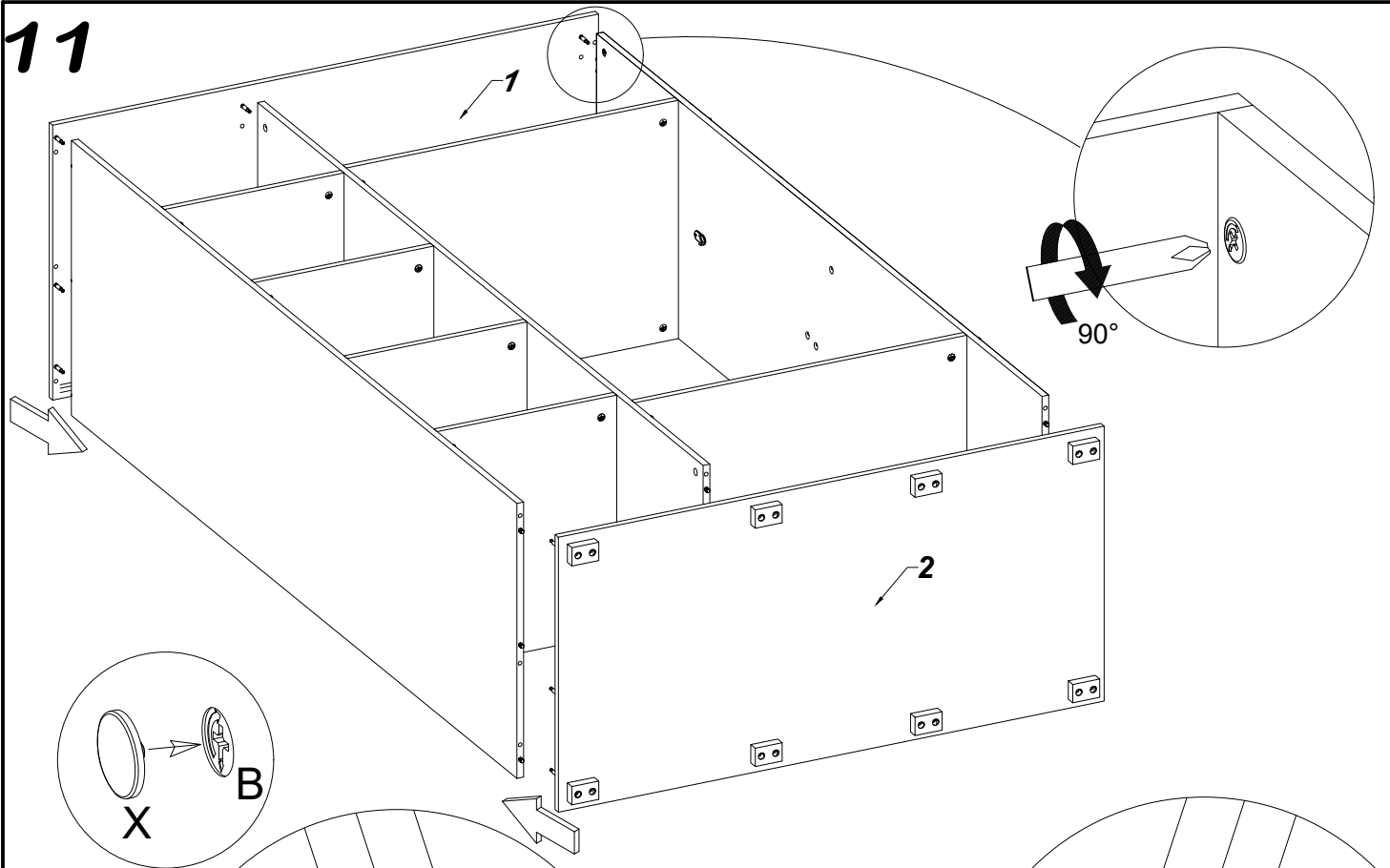

12

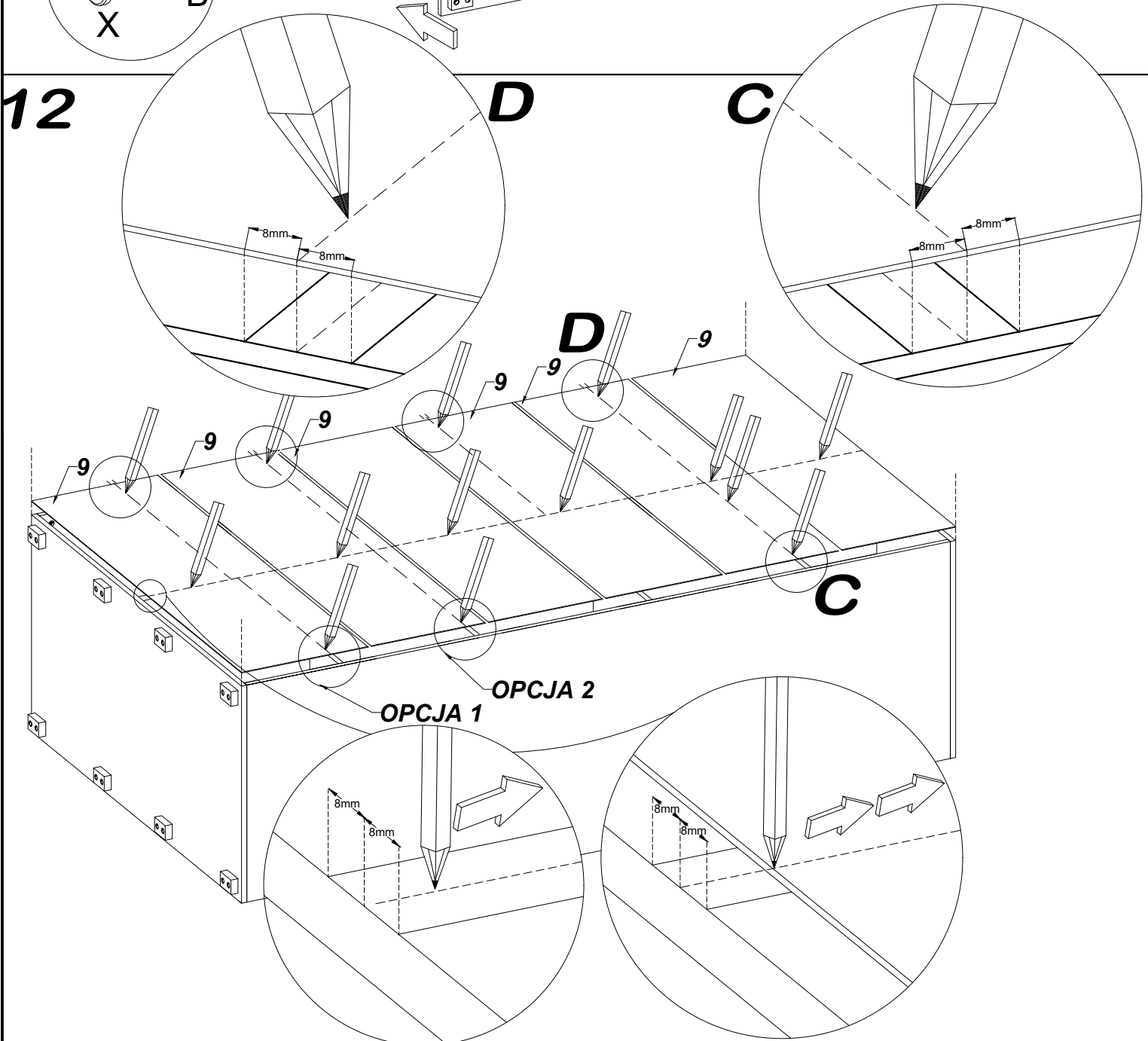

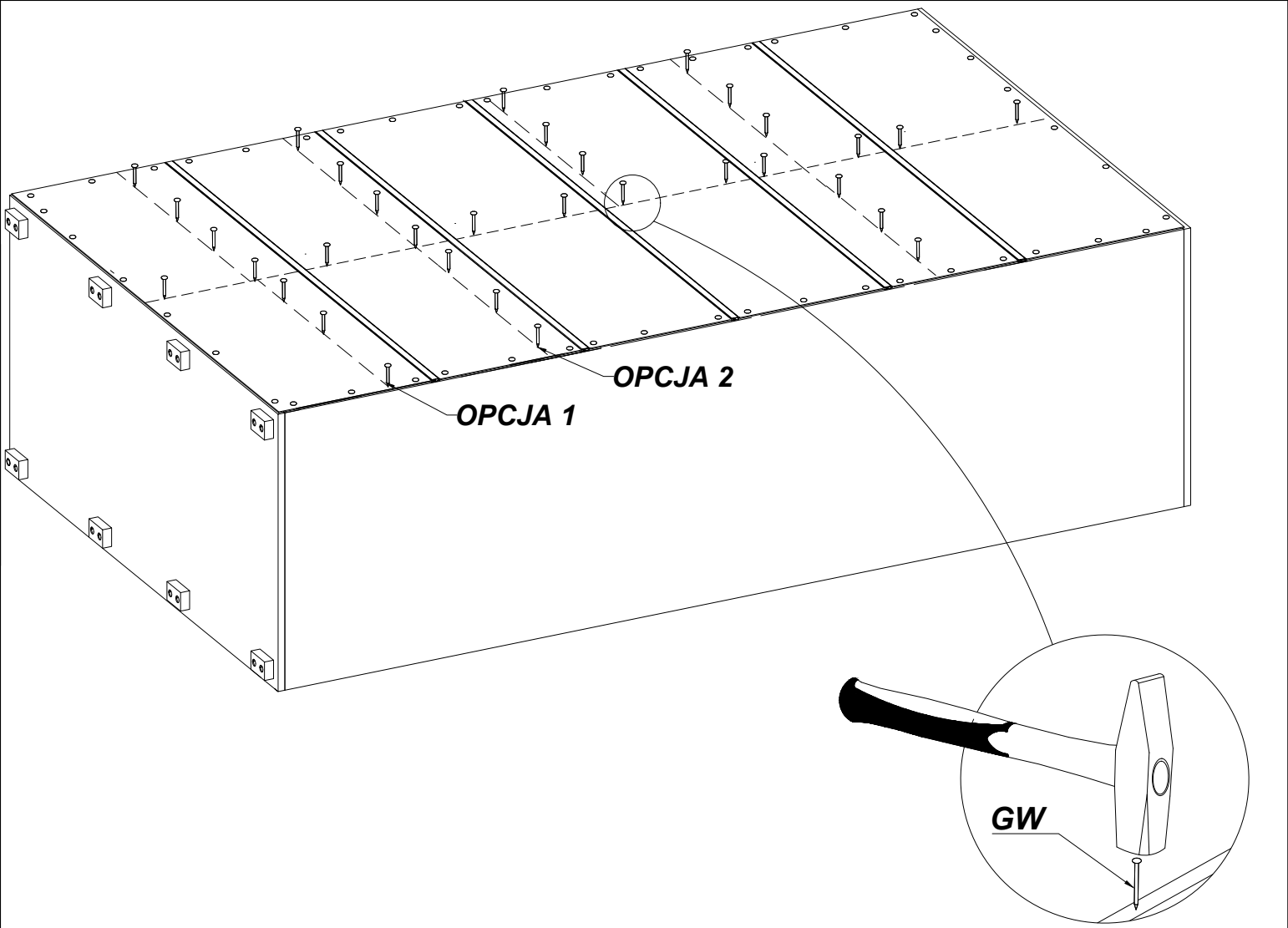
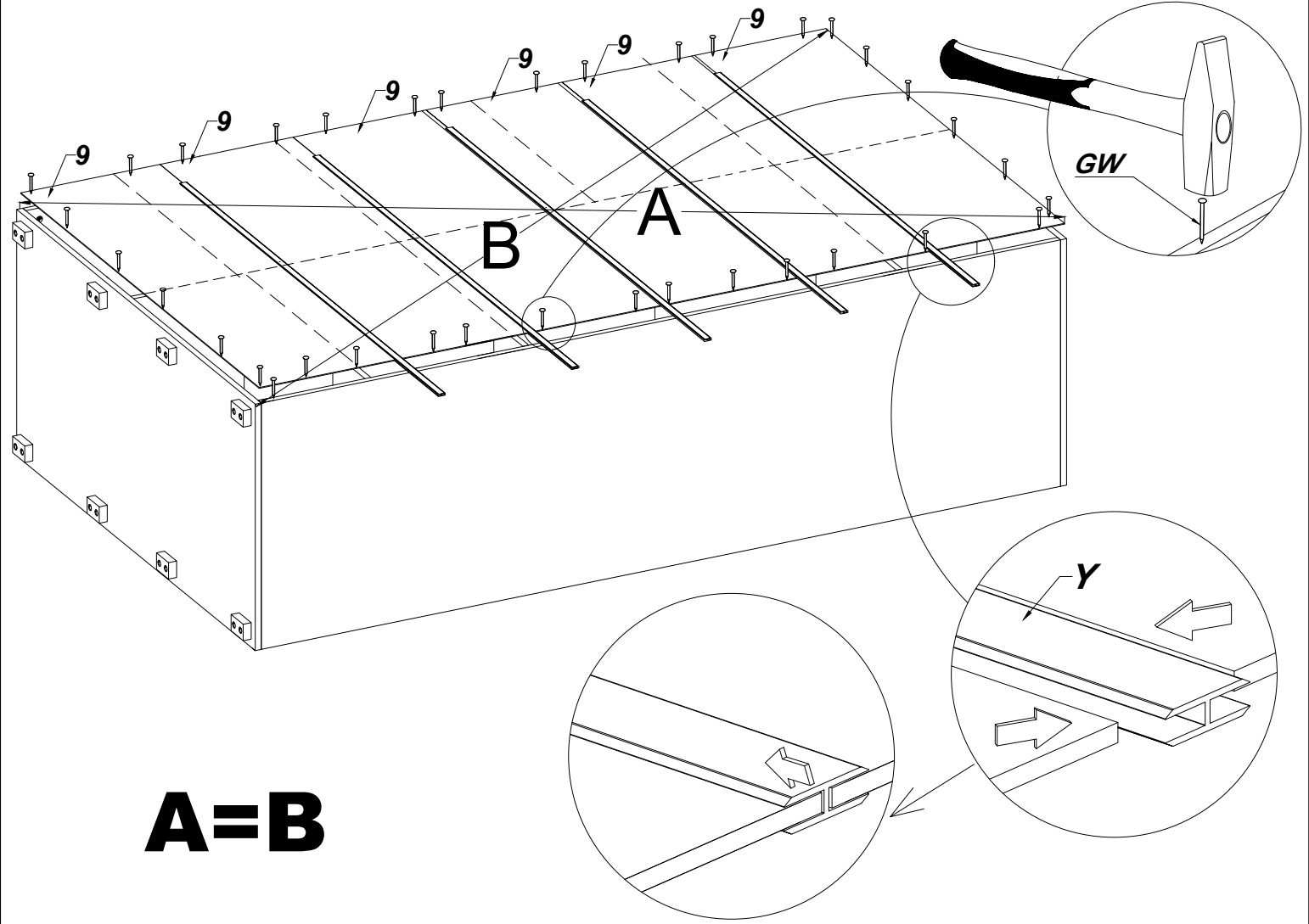

13

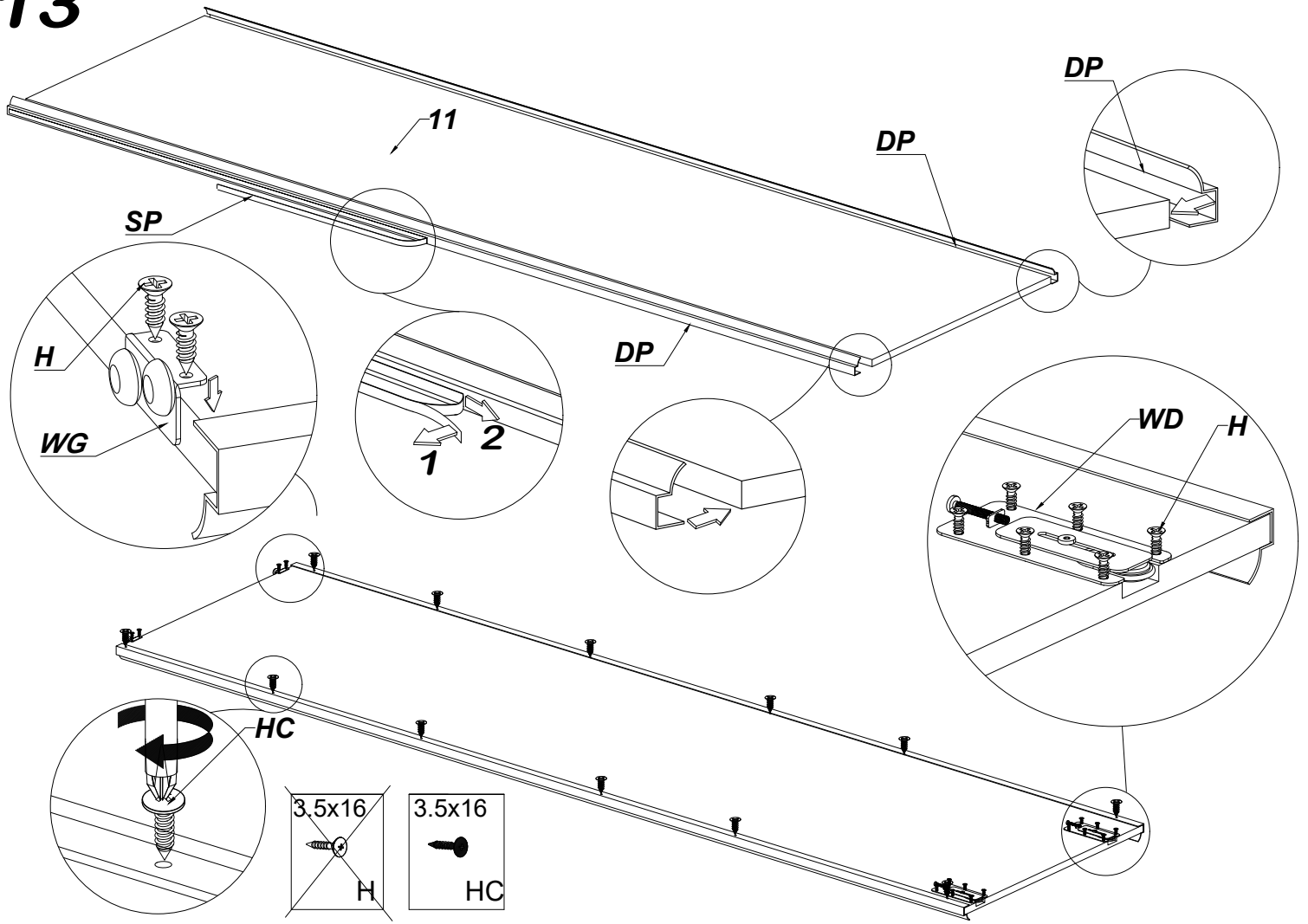

14

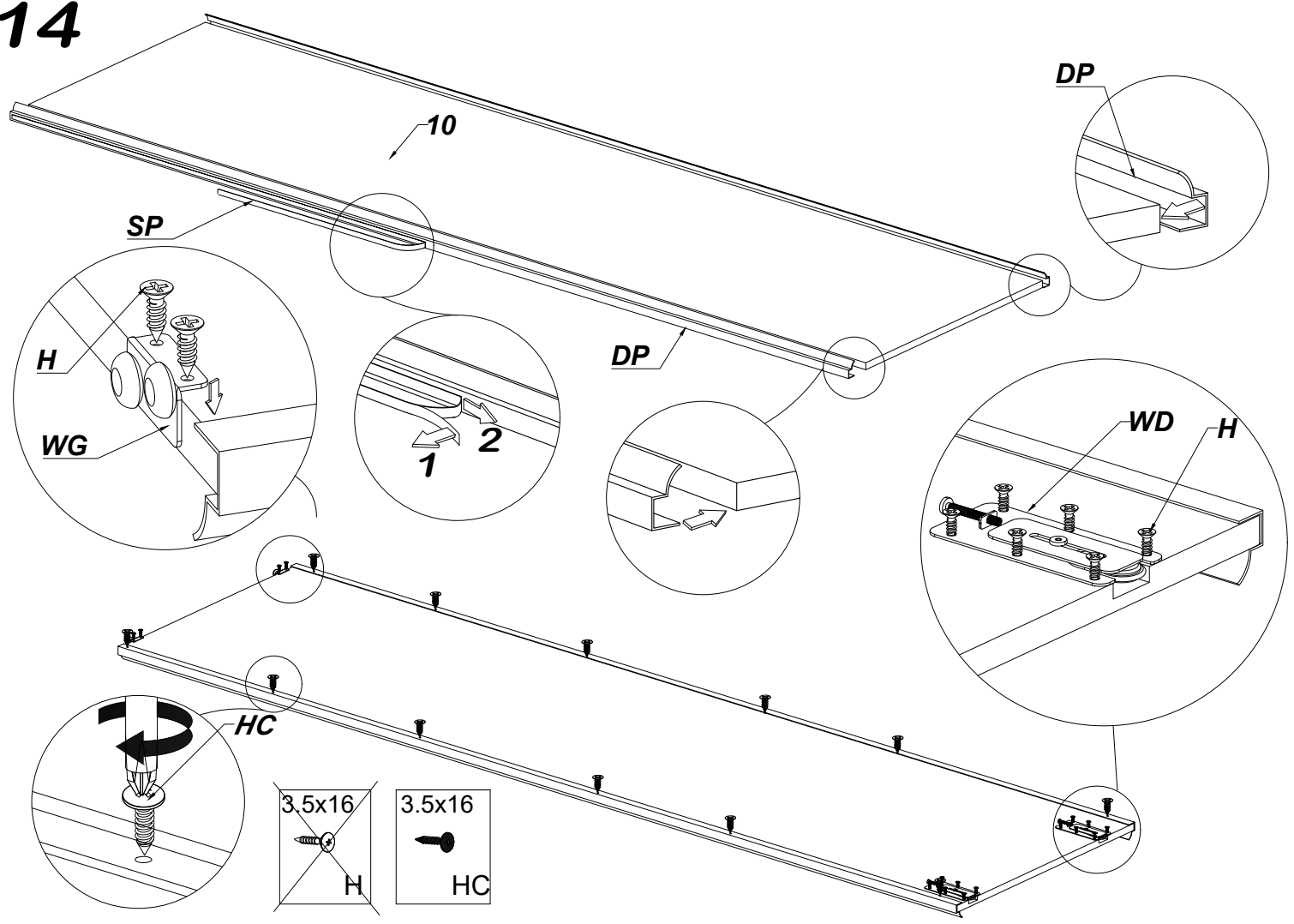

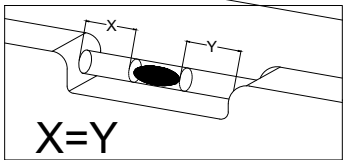
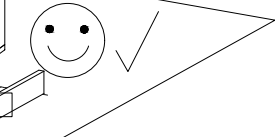
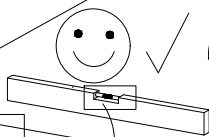
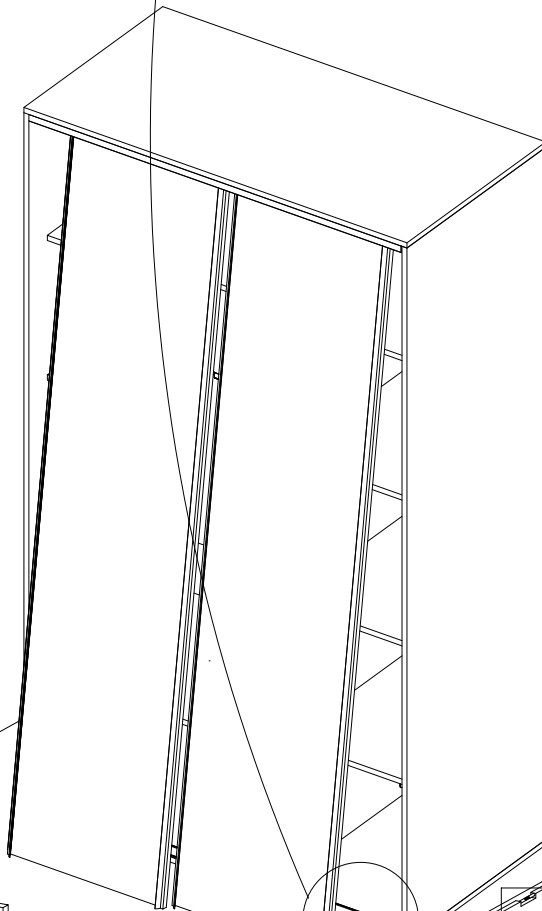
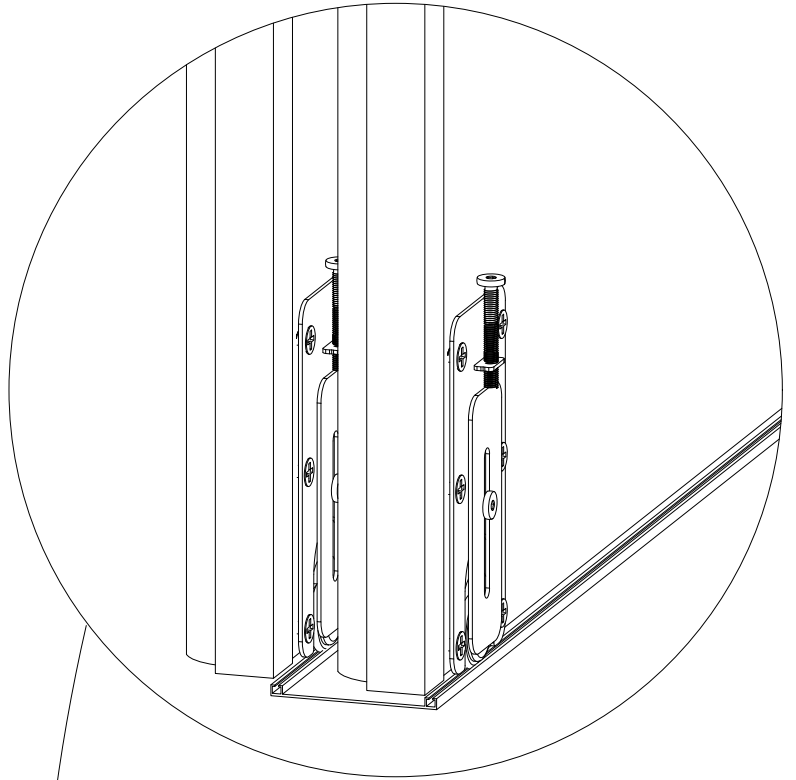

OPCJA "A"

PL
Instrukcja montażu kosza - znajduje się w opakowaniu z koszem.
GB
Basket installation instructions - included in the package with the basket
D
Installationsanleitung für den Korb – im Paket mit dem Korb enthalten
NL
Mandinstallatie-instructies - inbegrepen in het pakket met de mand
F
Instructions d'installation du panier - incluses dans l'emballage avec le panier
CZ
Návod na montáž koše - součástí balení s košem
SK
Návod na montáž košíka - súčasťou balenia s košíkom
HR
Upute za montažu košare - nalaze se u paketu s košarom
SRB
Упутство за постављање корпе - укључено у пакет са корпом

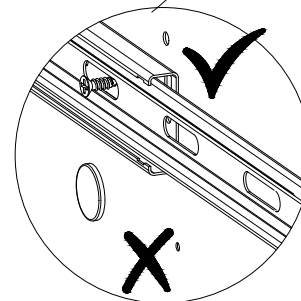
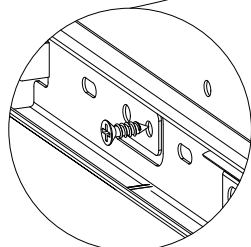
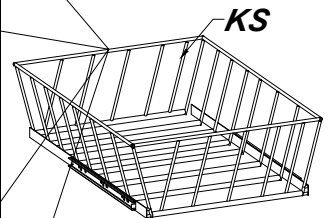
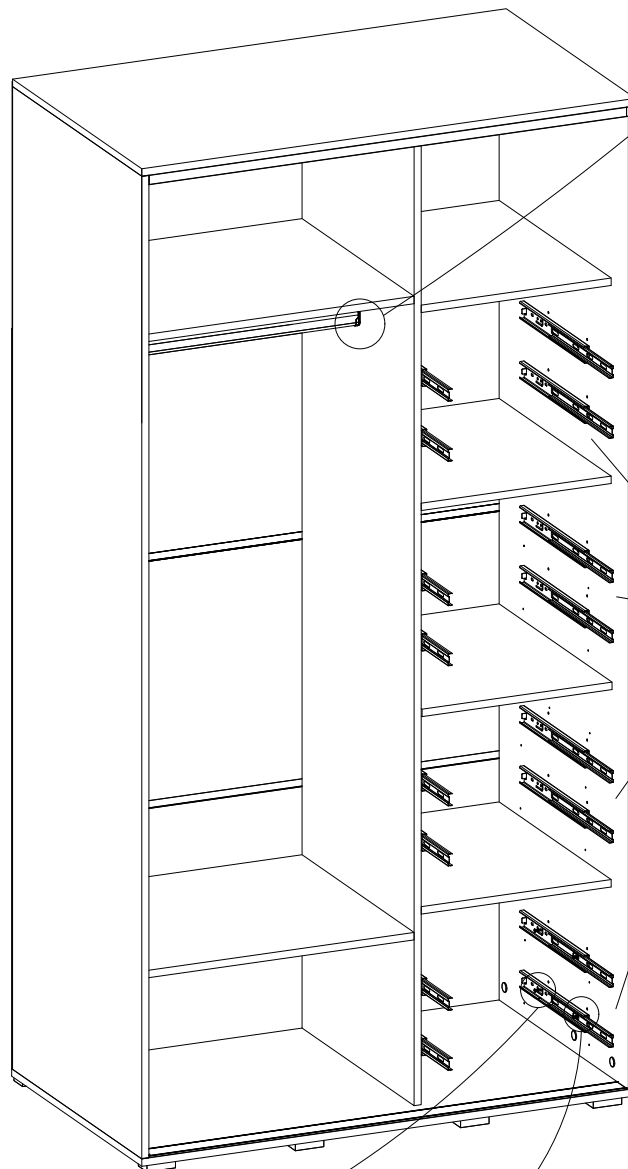
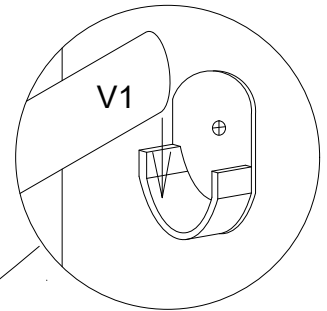
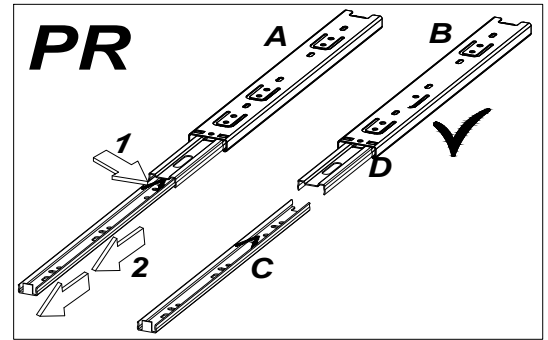

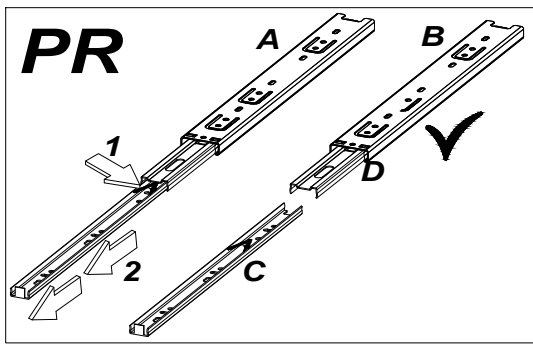

		3.5x16
PR		H
2		24
X	A	M
8	8	8
		D
		8

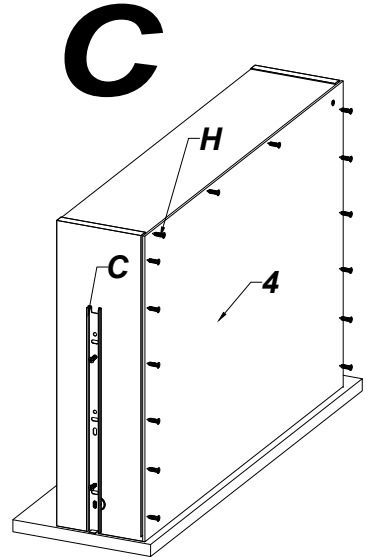
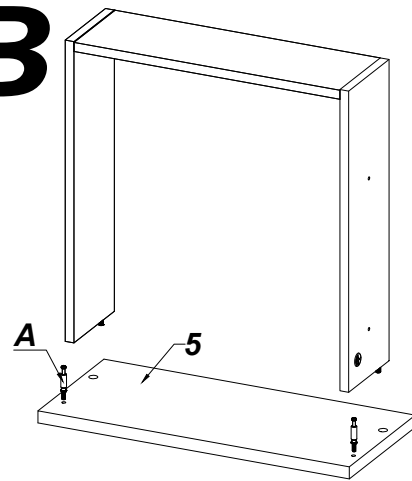
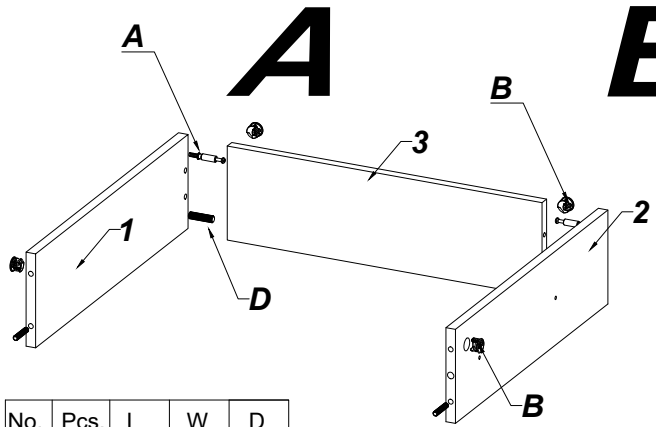

No.	Pcs.	L	W	D
1.	2	450	110	16
2.	2	450	110	16
3.	2	418	110	16
4.	2	453	446	3
5.	2	160	468	16

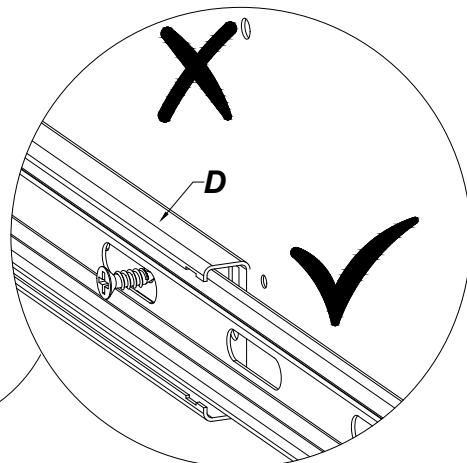
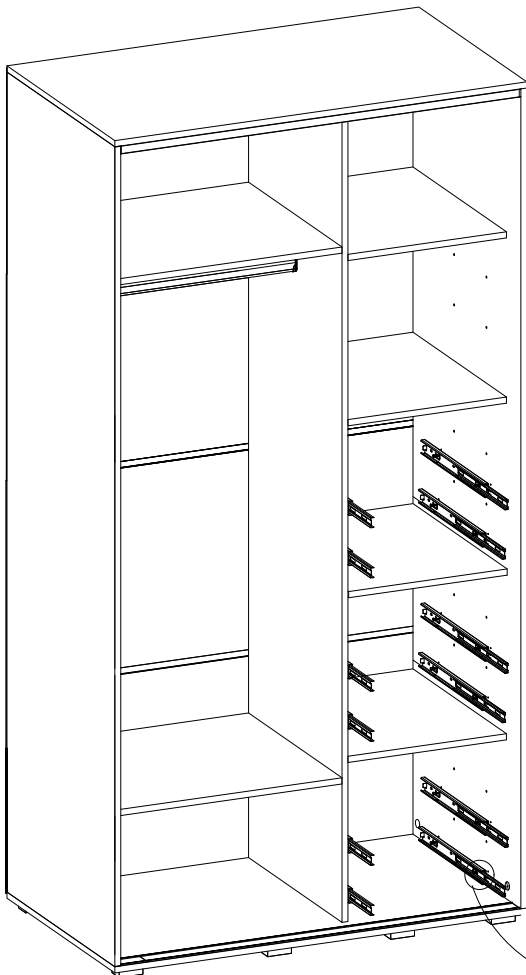

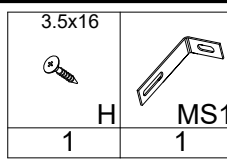
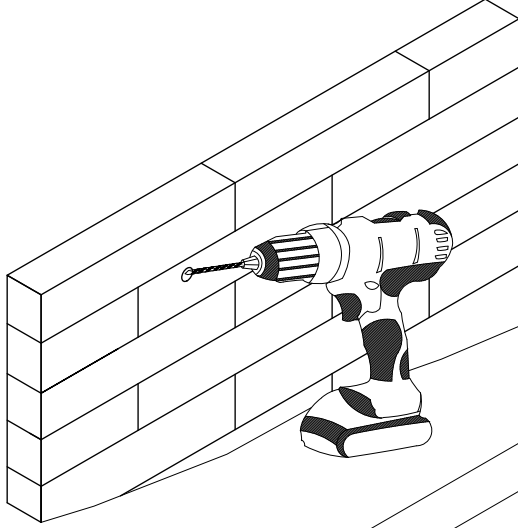
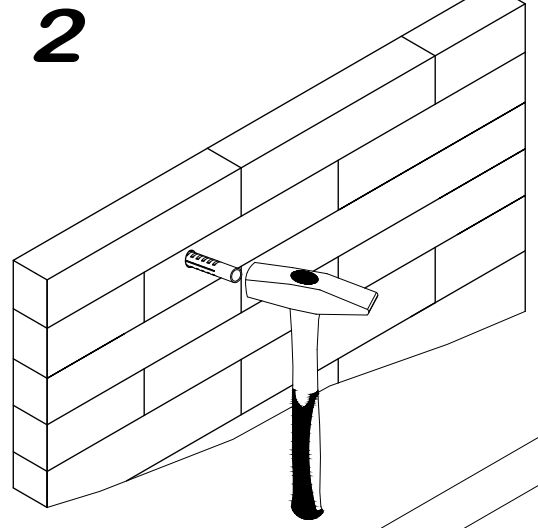
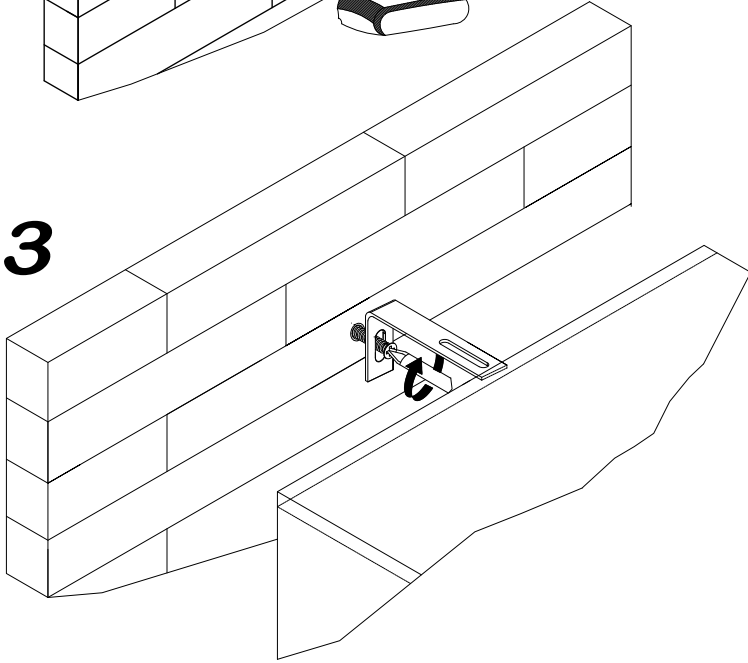
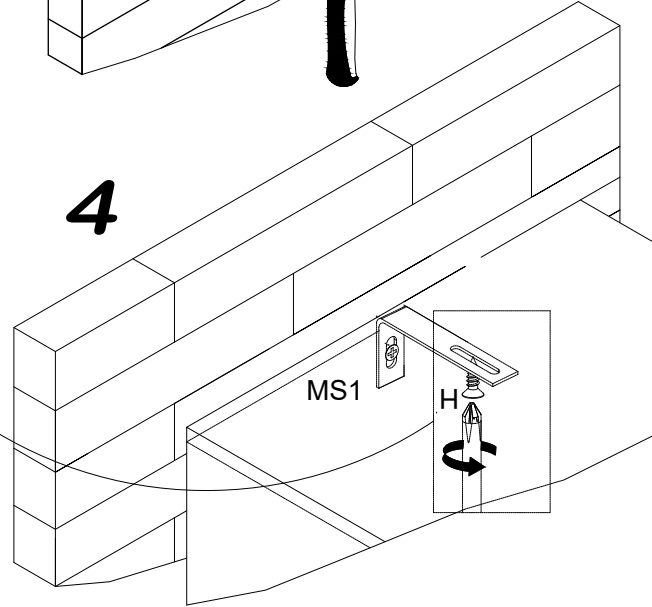
1**2****3****4**

Przy montażu artykułu na ścianie należy zastosować odpowiednie do niej zamocowania. W razie wątpliwości prosimy zasięgnąć porady fachowca.

PL

Uwaga: Mocowanie mebla do ściany mogą przeprowadzić wyłącznie wykwalifikowane osoby, z uwagi na zastosowanie odpowiednio dopasowanych kołków do rodzaju ściany.

Für andere Wandaufbauten sind eventuell Spezialdübel und andere Schrauben notwendig. Ziehen Sie gegebenenfalls eine Fachkraft zurate.

D

Achtung: Die Befestigung des Möbelstückes an der Wand muss von einer fachkundigen Person vorgenommen werden, da für die Montage an die Wand angepasste Dübel erforderlich sind.

Special dowels and other screws may be necessary for other wall constructions. If necessary, please consult a qualified professional.

GB

Attention: A qualified professional is required when mounting furniture to the wall since dowels corresponding to the wall are required for this.

Pour les autres constructions de murs, il faut éventuellement des chevilles spéciales et d'autres vis. Faites-vous conseiller par un spécialiste.

F

Attention : La fixation du meuble contre le mur doit être effectuée par une personne compétente car, pour le montage mural, il faut utiliser des chevilles adaptées.

NL

Voor andere muurconstructies zijn eventueel speciale pluggen en andere schroeven noodzakelijk. Consulteer eventueel een vakman

Opgelet: een vakkundige persoon dient het meubelstuk aan de muur te bevestigen; voor de montage aan de muur zijn immers aangepaste pluggen vereist.

CZ

Pro jiné skladby stěn budou případně nutné speciální hmoždinky a jiné šrouby. Poradte se případně s odborníkem.

Pozor: Montáž nábytku na stěnu musí provést odborník, protože k montáži na stěnu jsou zapotřebí upravené hmoždinky.

SK

Preiné steny sú potrebné príp. špeciálne hmoždinky a iné skrutky. V prípade potreby sa poraďte s odborníkom.

Pozor: Upevnenie nábytku na stenu musí vykonať odborník, nakoľko sú pre montáž na stenu potrebné vhodné hmoždinky.

HR

Kada montirate proizvod na zid, koristite odgovarajuće pričvršne elemente. Ako ste u nedoumici, obratite se stručnjaku.

Naopomena: Pričvršćivanje namještaja na zid smiju izvoditi samo kvalificirane osobe, zbog upotrebe pravilno usklađenih tiplova s vrstom zida.

SRB

Када монтирате артикал на зид, користите одговарајуће причвршћиваче. Ако сте у недоумици, обратите се професионалцу.

Напомена: Причвршћивање намештаја на зид смеју да обављају само квалификоване особе, због употребе типлова који су правилно прилагођени типу зида