

Installation Instruction

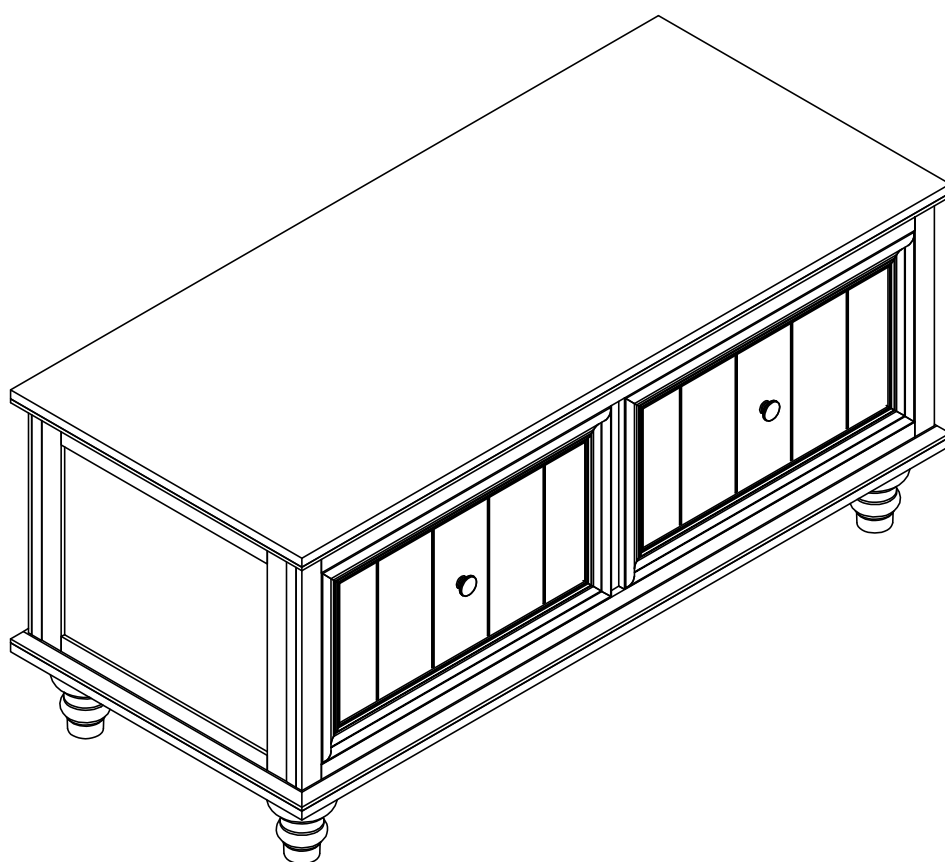

Assembling

What you need

- Use the packaging carton as a working surface to prevent product damage during assembly
- Phillips head screwdriver

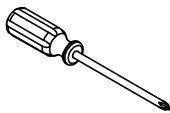

Weight Limitation

100 | **35**
 lbs table top lbs per

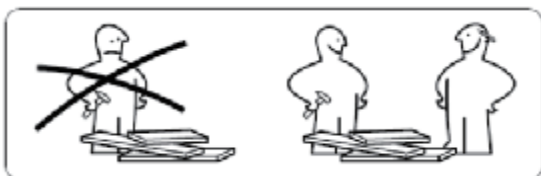

What' included

Code	Description	Qty
A	Cam Bolt M6X35MM	8
B	Cam Lock 15X9MM	8
C	Wooden Dowel M6X30MM	12
D	Screw M4X50MM	10
E	Screw M3.5X14MM	20
F	Left regulator	1
G	Right regulator	1
H	Screw M3.5X14MM	20
I	Foot nail	4
J	Wrench M4X55MM	1
K	Phillips screwdriver	1
L	Hole position sticker	8
M	Screw M6X25MM	2
N	Four-hole iron sheet	4
O	Four hole iron sheet	1
P	Adjustable Leveler	1
Q	Cam Bolt M4X22MM	2
K	Metal shake handhandle	2

The Hardwares

A

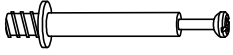

B

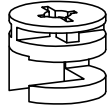

C

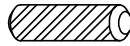

D

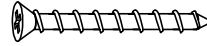

E



F

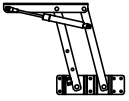

G

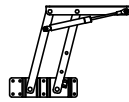

H



I



J



K



L

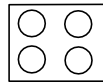

M



N

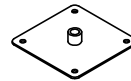

O

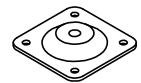

P



Q



R



IMPORTANT:

1. Do not tighten bolts / screws completely until all bolts / screws are lined up and inserted into holes.
2. Do not over tighten screws and bolts to avoid stripping
3. Please use hand tools to assemble this product, you can also use power tools (please use power tools carefully)

Included Accessories

Code	Description	Qty
1	Cabinet Top	1
2	Bottom Panel	1
3	Left Side Panel	1
4	Right Side Panel	1
5	Front apron	1
6	Backboard	1
7	Solid wood foot	4
8	Adjustable foot	1
9	Connecting pipe	1

The Accessoriess

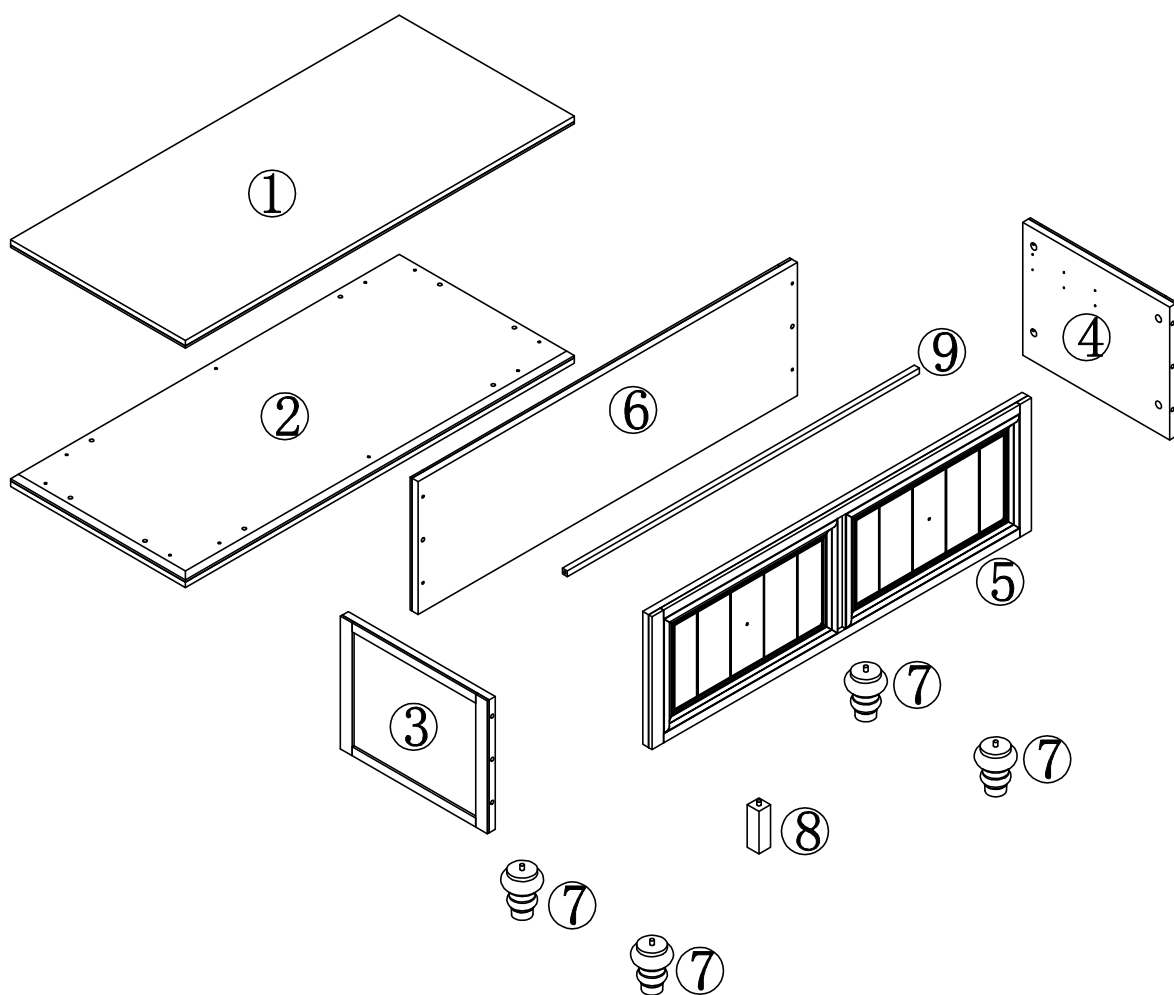

Step 1

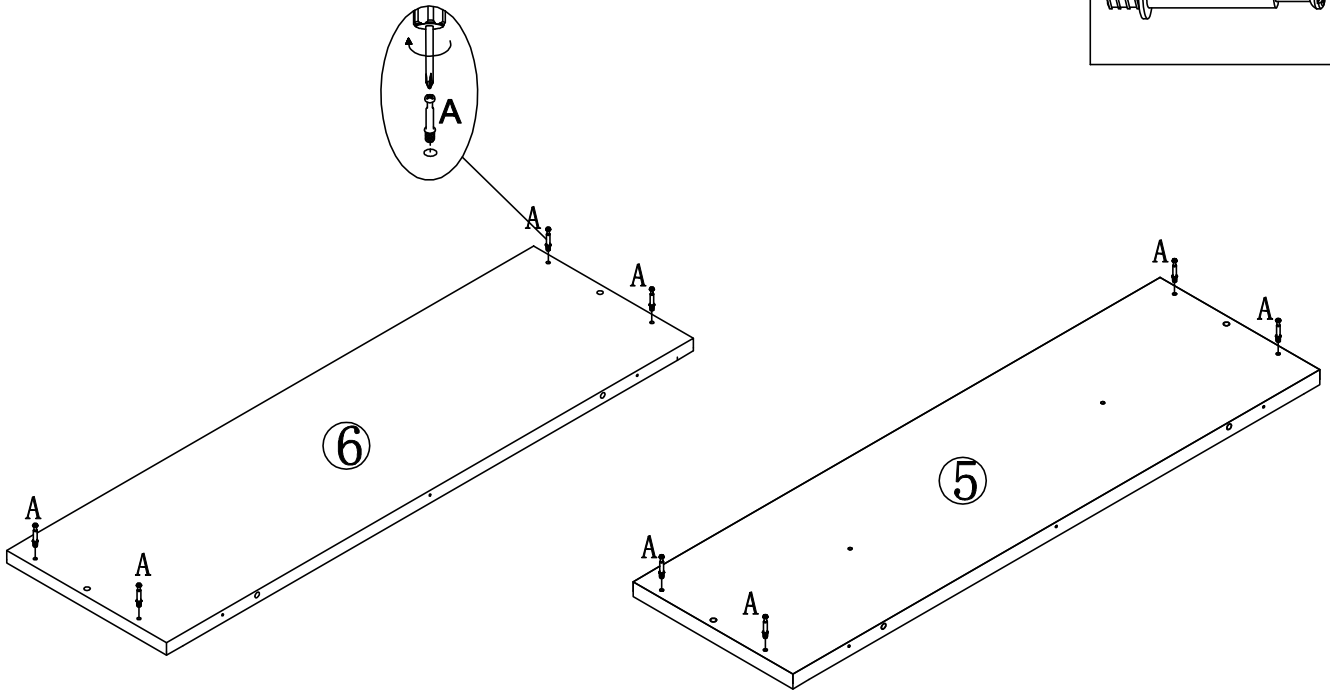
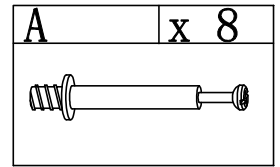

Step 2

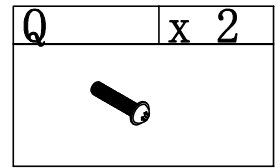
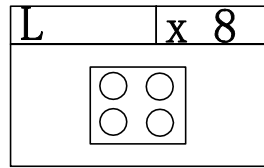
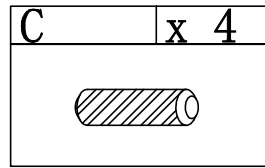
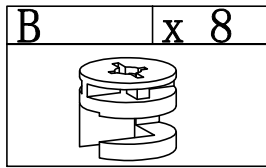

The long side of the borehole is all facing down

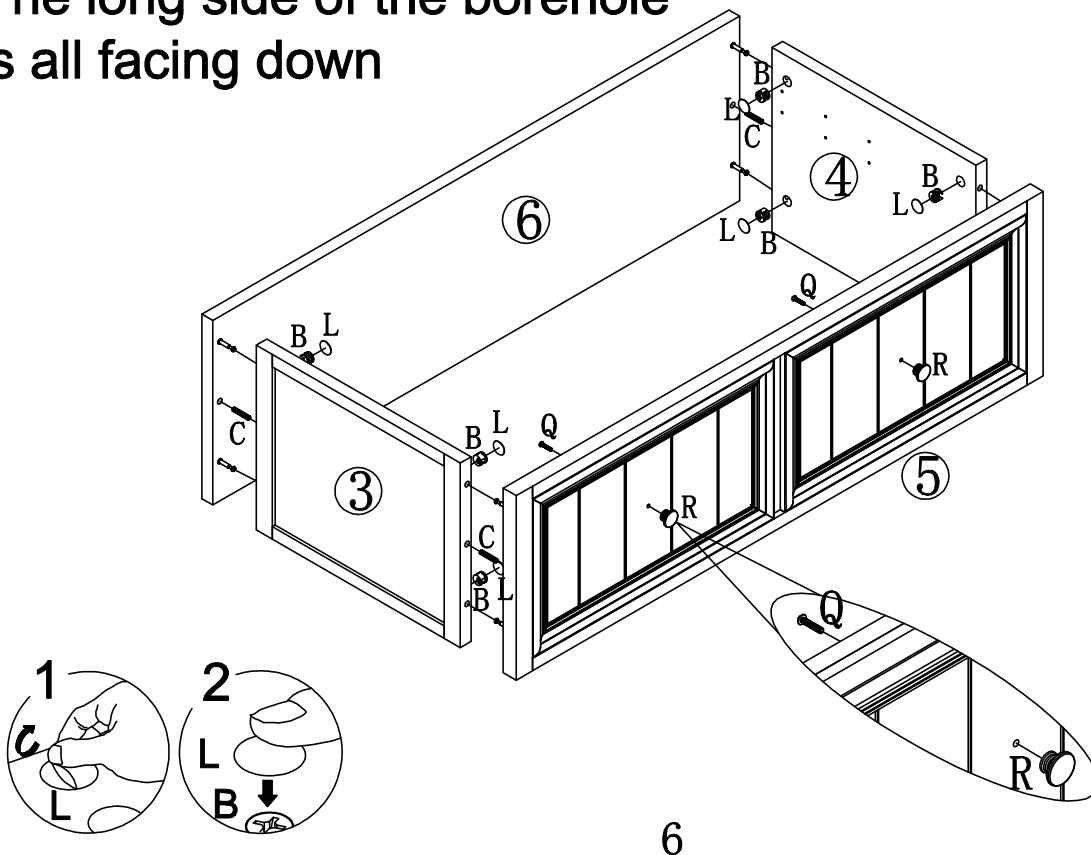
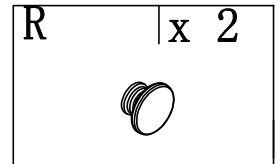

Step 3

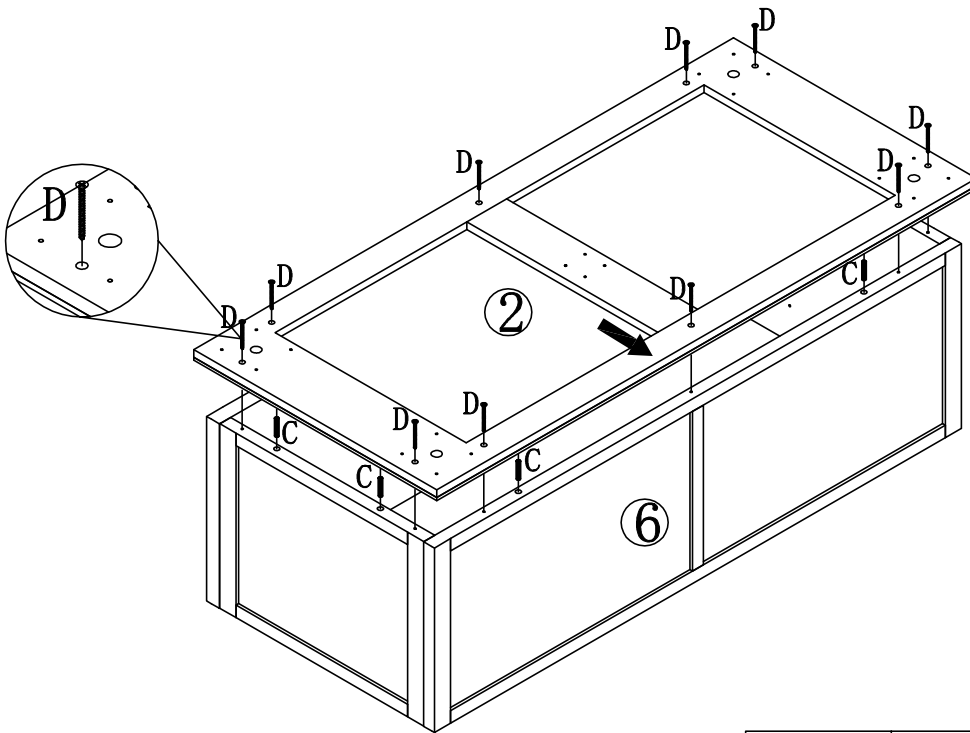
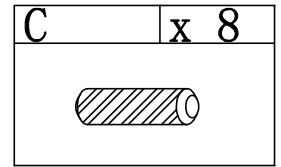
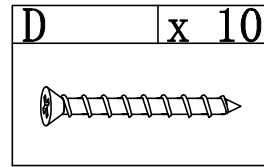

Step 4

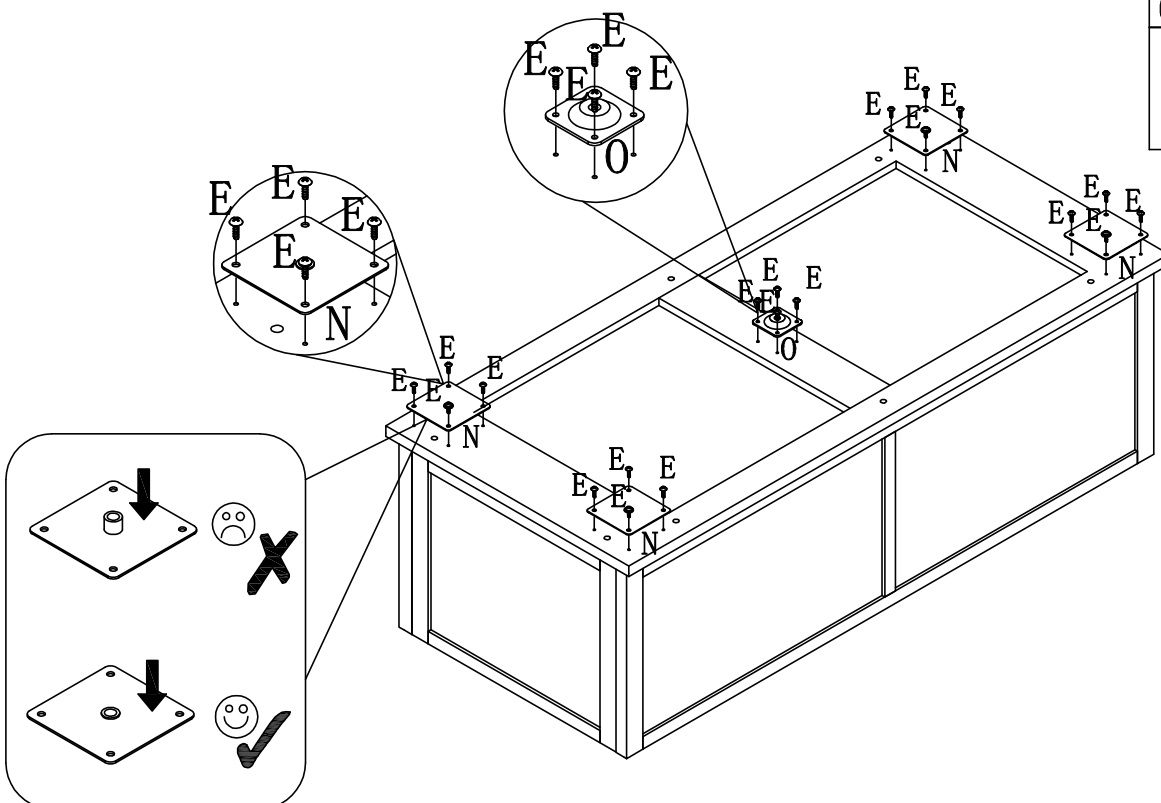
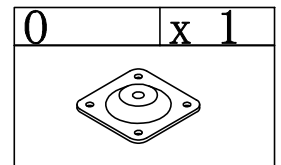
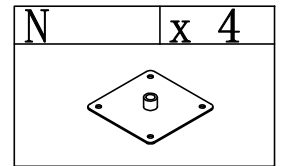
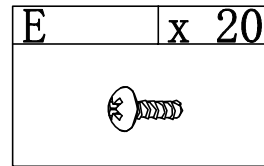

Step 5

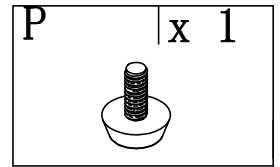
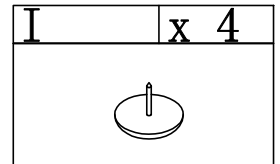
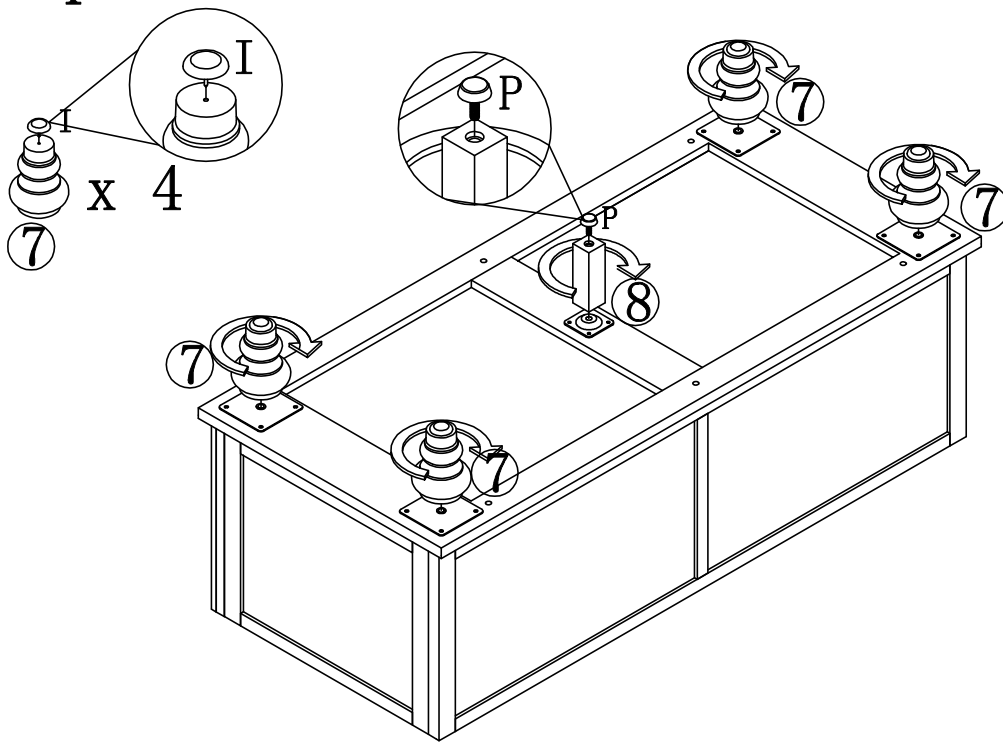

Step 6

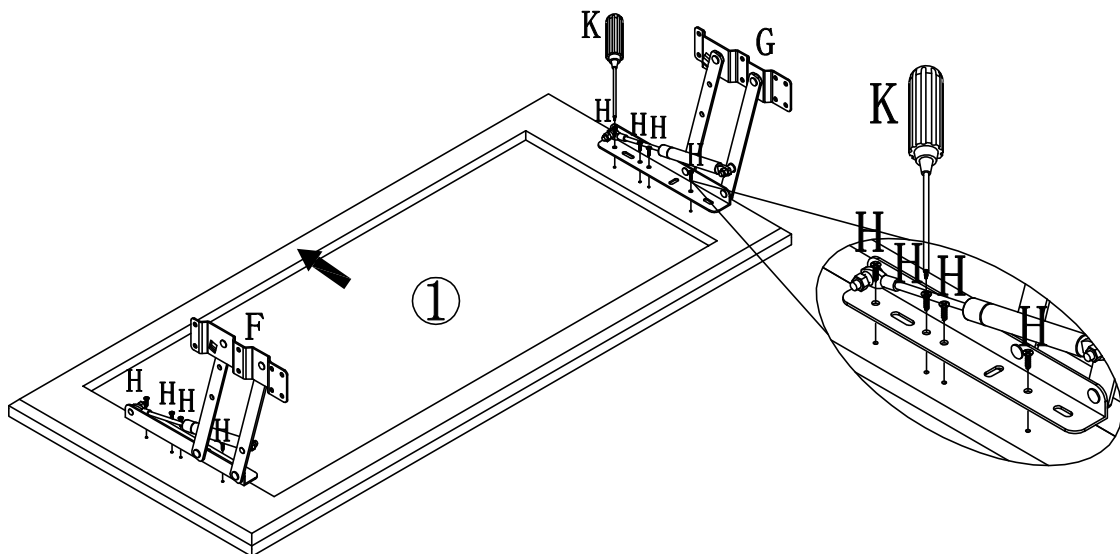
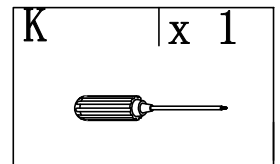
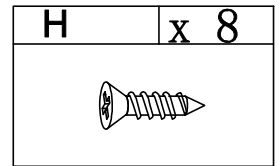
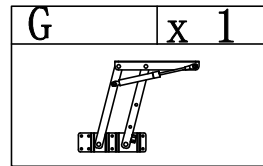
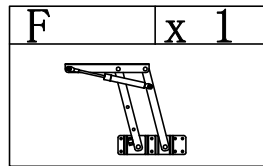

Step 7

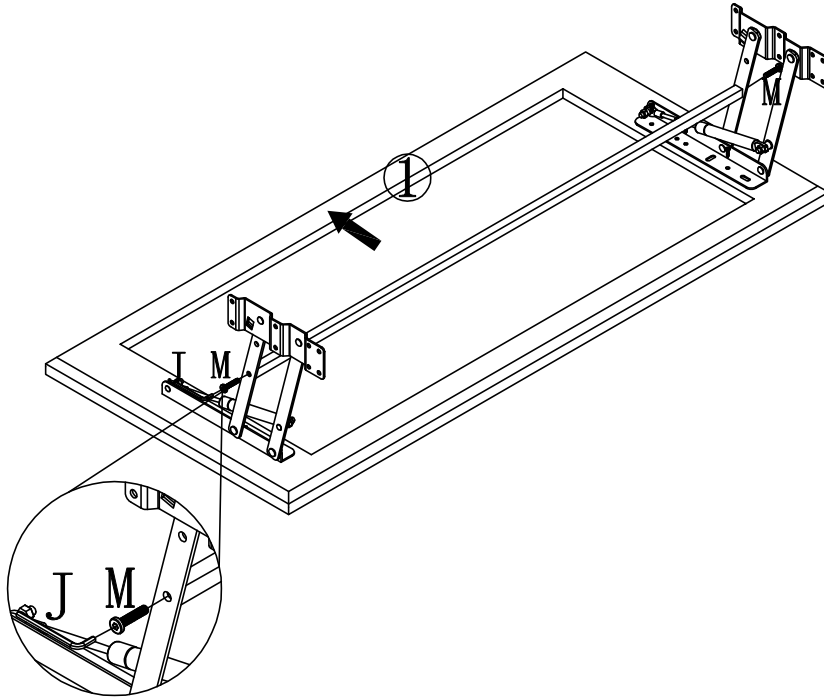
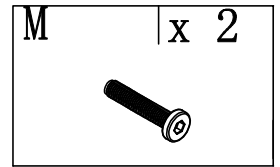
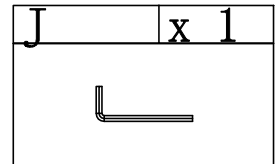

Step 8

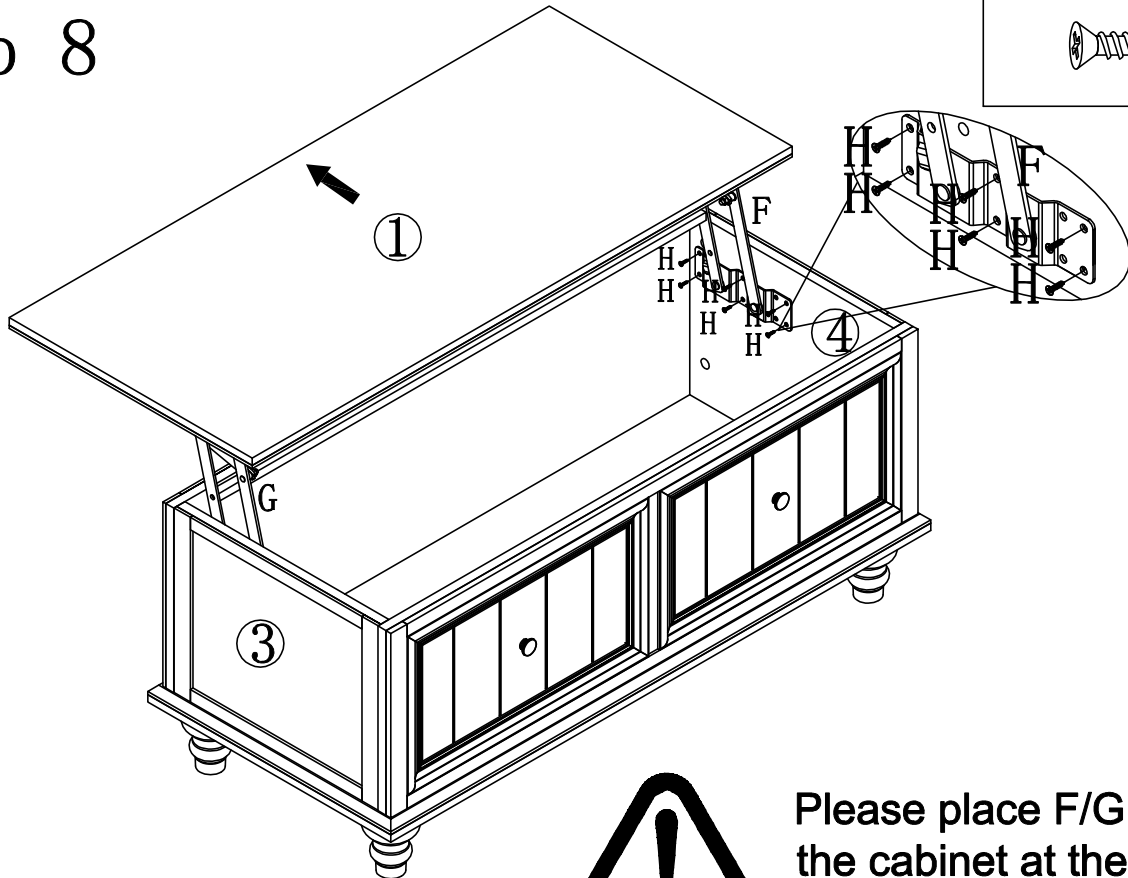
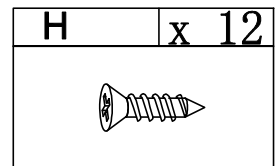

Please place F/G inside the cabinet at the same time as shown

Step 9

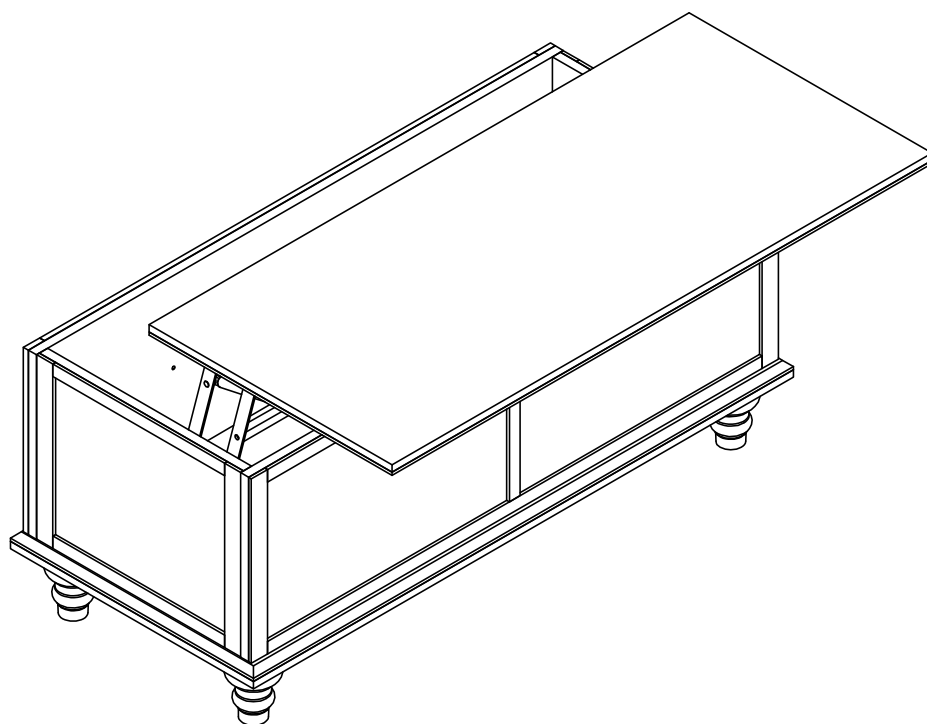
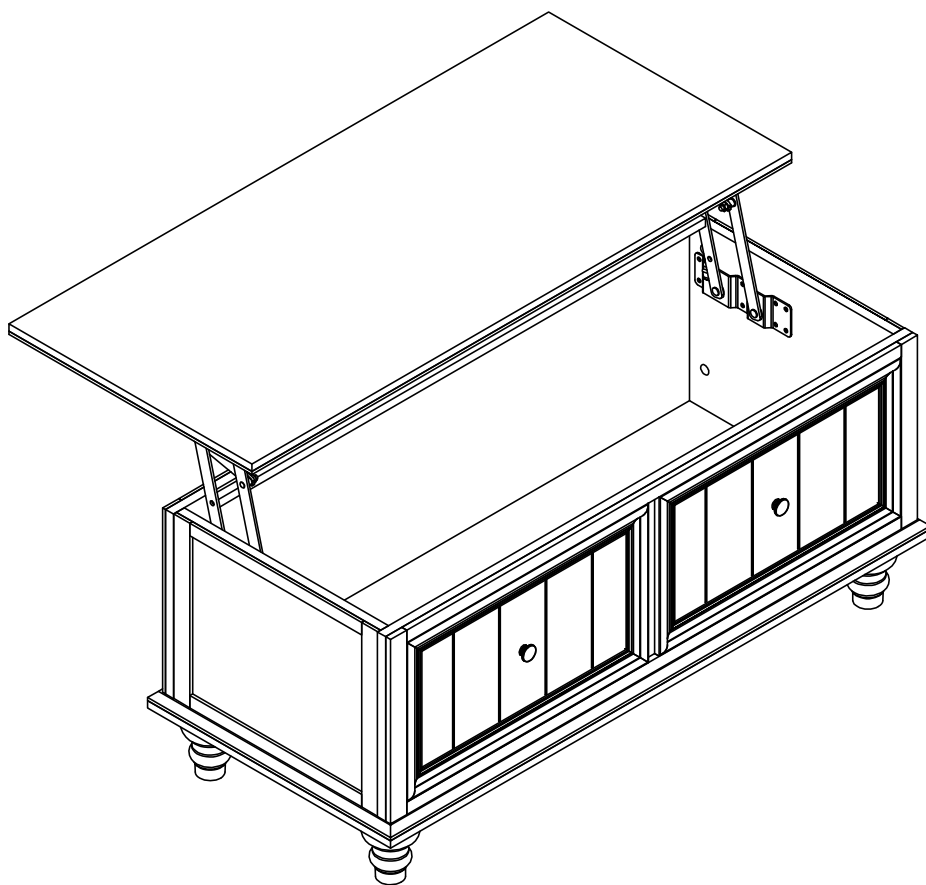

Step 10

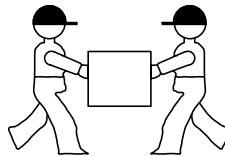
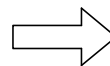
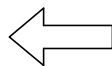
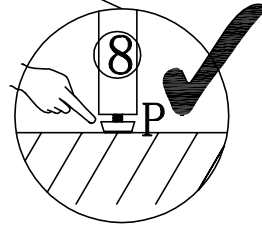
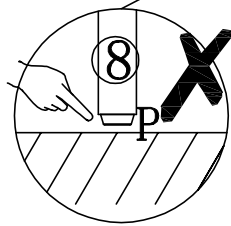
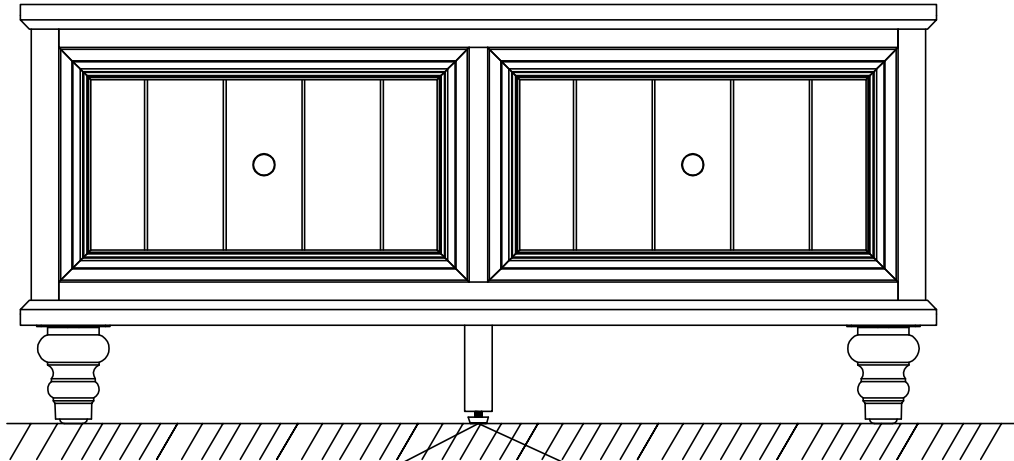

Two people work together to move the table.
Make sure you lift it off the ground.
Don't push and pull.