

Cymbal  
Round Flush Ceiling Light Brushed  
Chrome Bezel Opal Glass

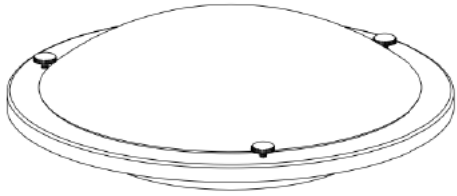

LSE Retail Group  
0161 832 4957  
M44 5GR. UK

## CONTENTS

x1

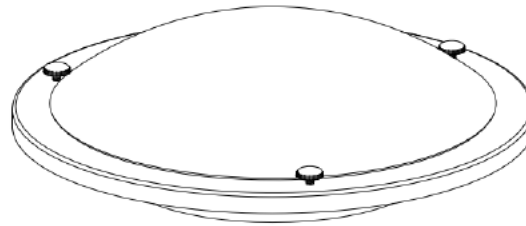

230-240V ~ 50Hz  
MAX 60W E27 GLS



## ASSEMBLY

1.

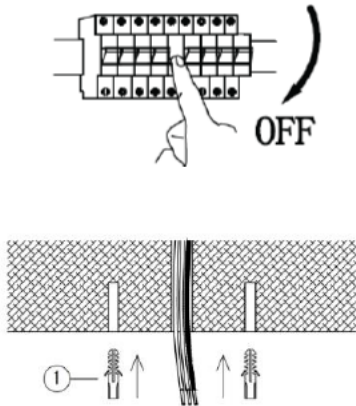

2.

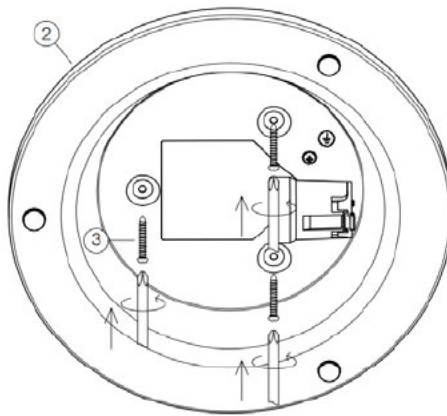

3.

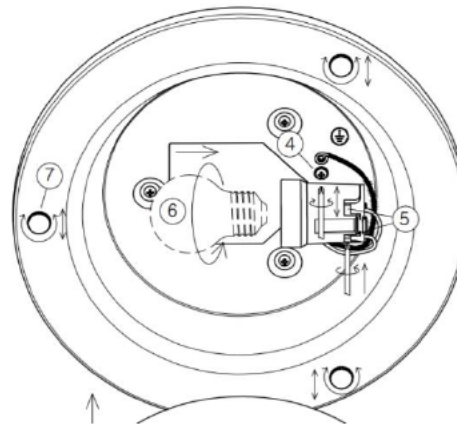

4.

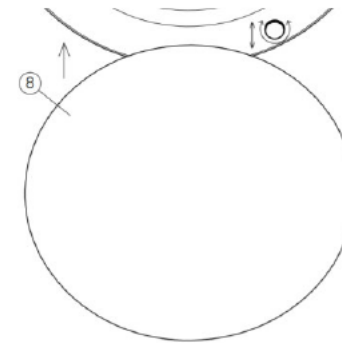

5.

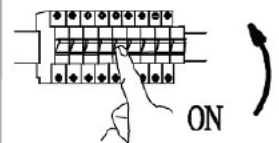

## CAUTION

**Read all safety instructions carefully and keep for future use.**

Failure to comply with the following safety instructions may cause electric shock, fire and/or serious injury

## ELECTRICAL SAFETY

- Please choose screws and fixings that are suitable for the material that your ceiling is made of, if the ones supplied do not suit
- This is a Class I product and requires an Earth connection – 230 (240) volts ~50hz AC
- This fitting must be permanently wired into the electric system. Always shut off power to the circuit before starting installation work.
- Do not modify or alter any product before or after installation. This will invalidate your warranty and may render the product un-safe.
- Before inserting and replacing bulb(s) make sure that the power is switched off and the bulb(s) have cooled down.
- All connections should be covered by suitable insulation tape
- The terminal block should be housed within the mounting plate or a suitable recess behind the fitting.
- All wiring must conform to current I.E.E regulations
- This product must be installed in accordance with the national building regulations. If in doubt consult a competent electrician

**IF AT ALL UNSURE, STOP NOW AND SEEK PROFESSIONAL GUIDANCE**

## POSITION:

- For indoor use only
- Do not mount the fitting in a damp atmosphere.
- Be aware of any sunken pipes or wiring before choosing a location.
- Ensure there is a sufficient power supply and access to the fitting to enable safe maintenance

## ASSEMBLY AND SET-UP:

- **(DIA.1)** Turn power off at mains. Mark the positions of the fixing holes onto the walls surface ensuring that they align to the mounting holes on the fixing bracket. Drill holes on the marked positions with a 5mm drill bit.
- **(DIA.2)** Locate the wall plugs and fit the ceiling light in place (using the screws provided) taking care not to damage any of the supply wires or any sunken pipes.
- **(DIA.3)** Make the electrical connections in accordance with the diagram above. Fix the backplate to the fixing bracket with the side screws provided, taking care not to trap any supply wires. This product must be earthed. Insert the bulb (not supplied), refer to the wattage label for the type and wattage, do not exceed the wattage indicated on the label. Loosen the three outer ring hand screws.
- **(DIA.4)** Place the cover over the backplate, and then tighten the three outer ring hand screws to secure into place.
- **(DIA.5)** Turn power back on at mains.

## AFTERCARE AND MAINTANENCE:

- Always disconnect power supply when servicing or cleaning.
- Clean only with a dry or slightly damp cloth.