

ASSEMBLY INSTRUCTIONS

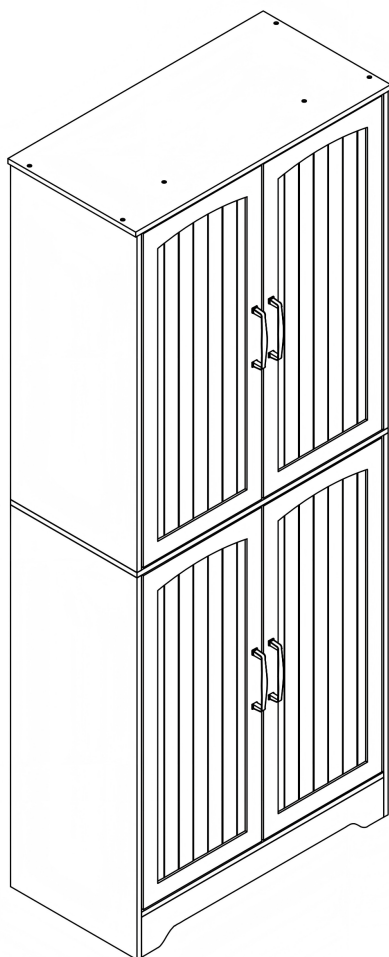

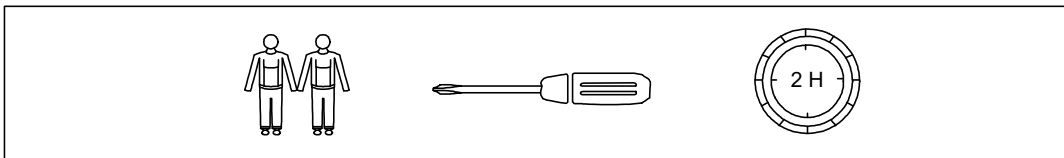

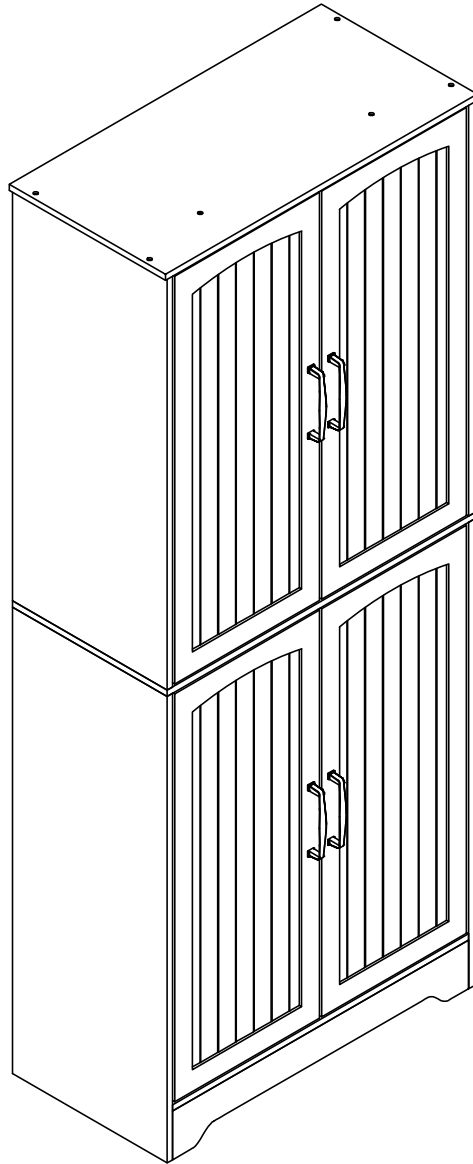

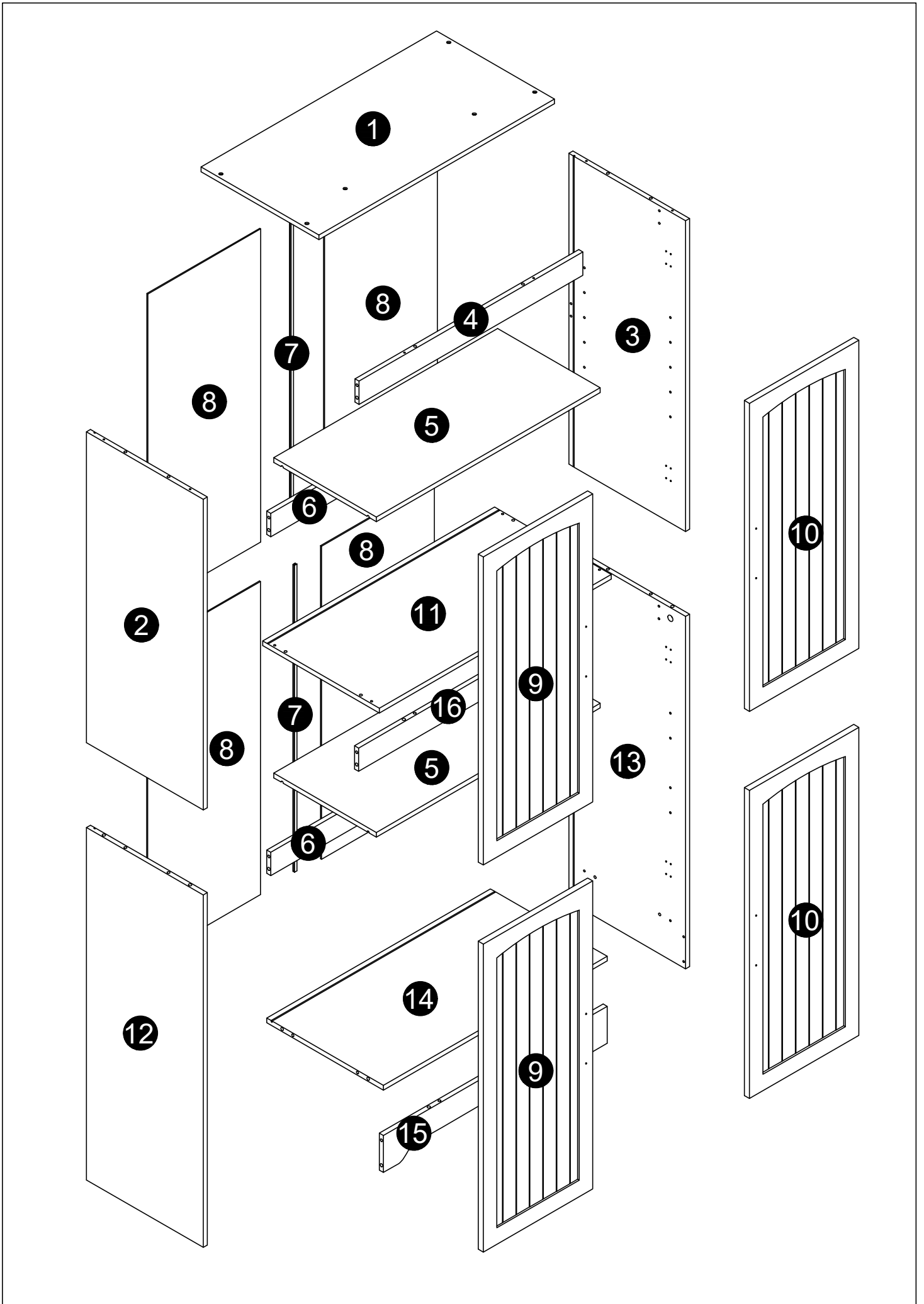

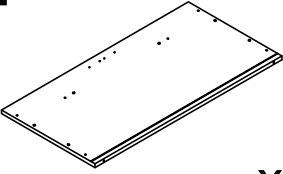
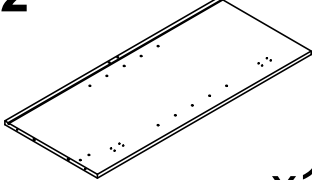
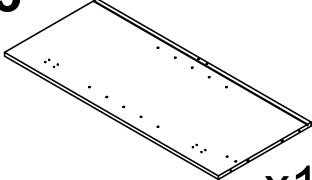
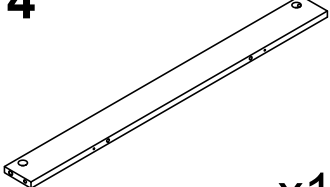
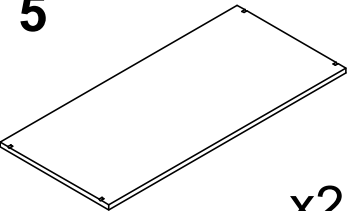
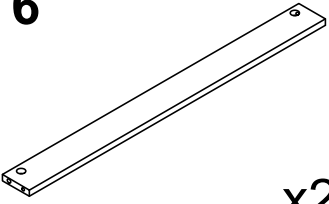
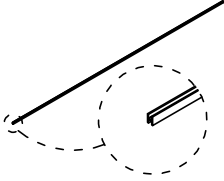
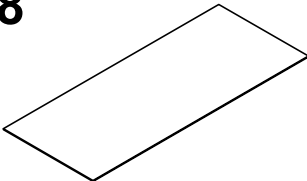
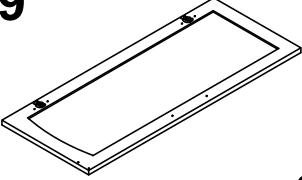
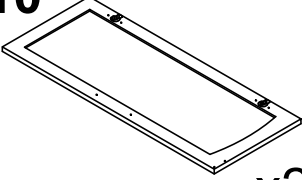
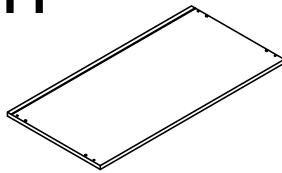
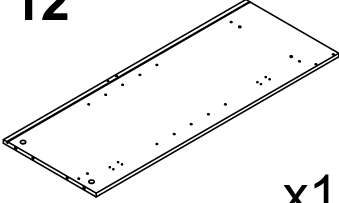
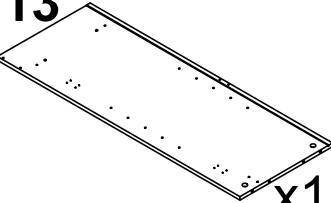
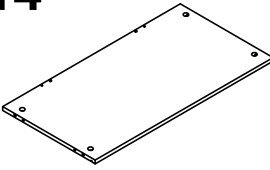
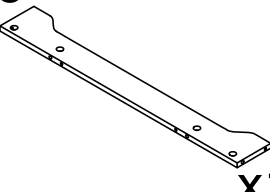
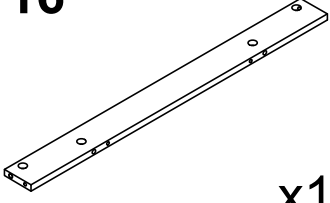

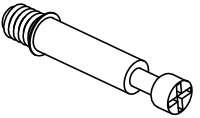

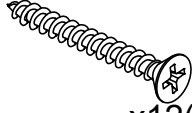

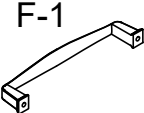
Four-door Cabinet

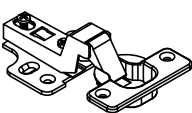



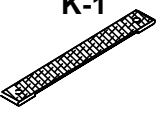

<p>1</p>  <p>x1</p>	<p>2</p>  <p>x1</p>	<p>3</p>  <p>x1</p>	<p>4</p>  <p>x1</p>
<p>5</p>  <p>x2</p>	<p>6</p>  <p>x2</p>	<p>7</p>  <p>x2</p>	<p>8</p>  <p>x4</p>
<p>9</p>  <p>x2</p>	<p>10</p>  <p>x2</p>	<p>11</p>  <p>x1</p>	<p>12</p>  <p>x1</p>
<p>13</p>  <p>x1</p>	<p>14</p>  <p>x1</p>	<p>15</p>  <p>x1</p>	<p>16</p>  <p>x1</p>

A 6x35mm  x22(+2)	B 15x10mm  x22(+2)	C 6x30mm  x32(+3)	D 4x35mm  x12(+1)	E 3.5x12mm  x56(+5)
F 4x18mm F-1  F-2  x4	G  x8	H 3x16mm H-1  H-2  x20	I 6x30mm  x2	J  x8
K 4x14mm K-1  K-2  x2	L 3x16mm L-1  L-2  x4	M  x4		

Step 1

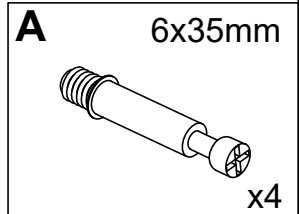
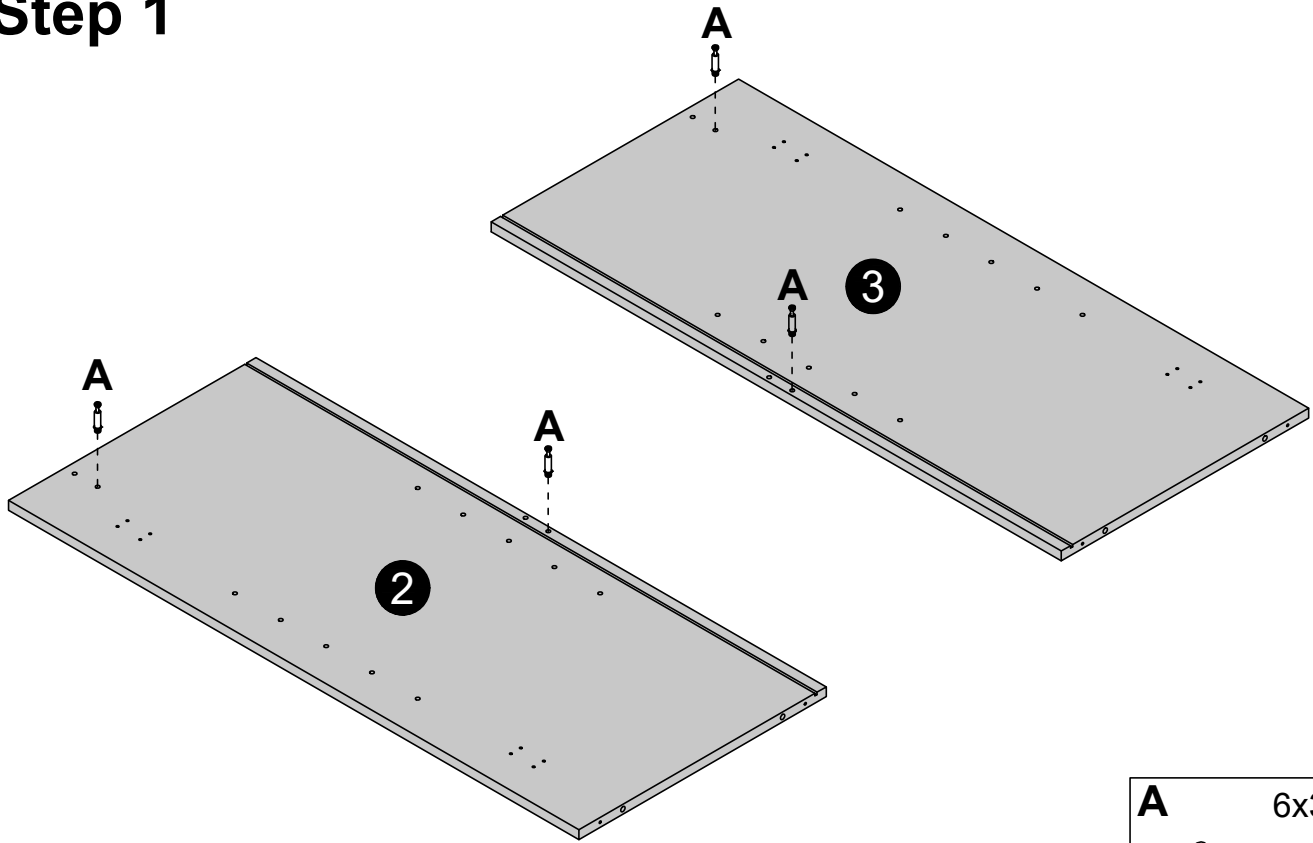

Step 2

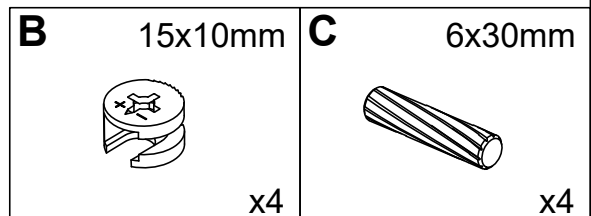
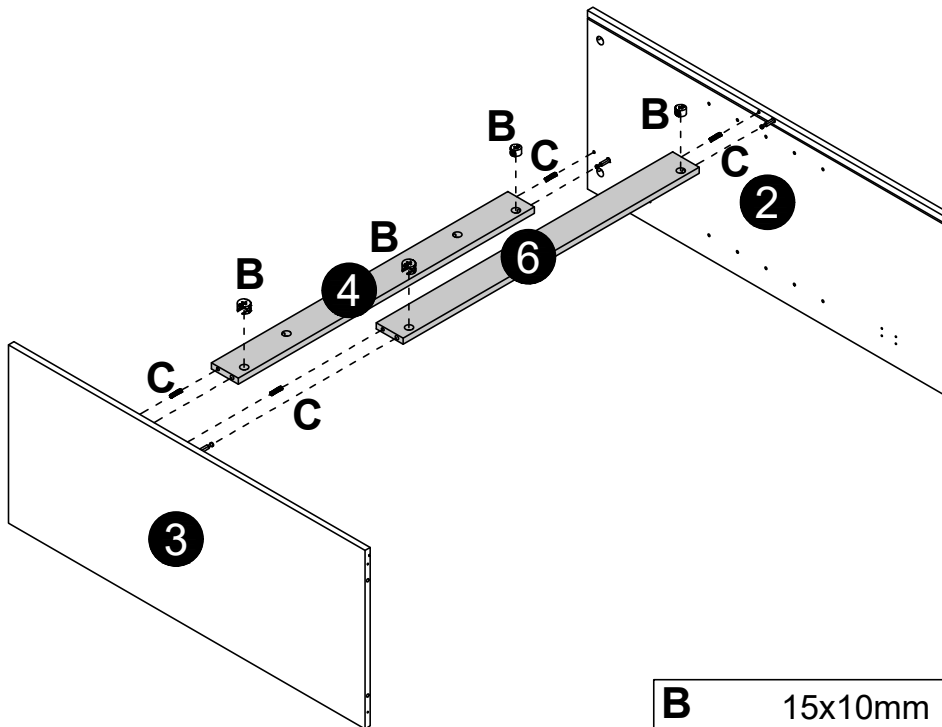

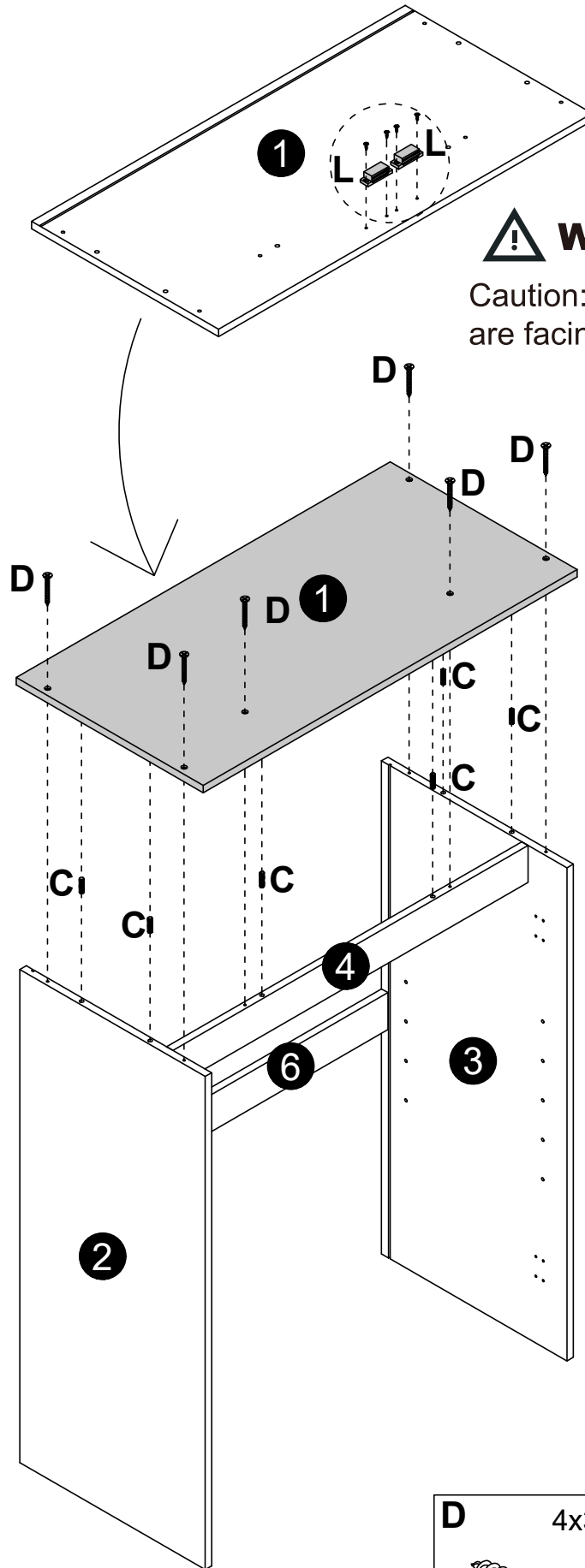

Step 3

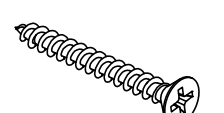

⚠ WARNING

Caution: Make sure the magnets are facing the right way!

<p>C 6x30mm</p>  <p>x6</p>	
<p>D 4x35mm</p>  <p>x6</p>	<p>L 3x16mm</p> <p>L-1 L-2</p>  <p>x2</p>

Step 4

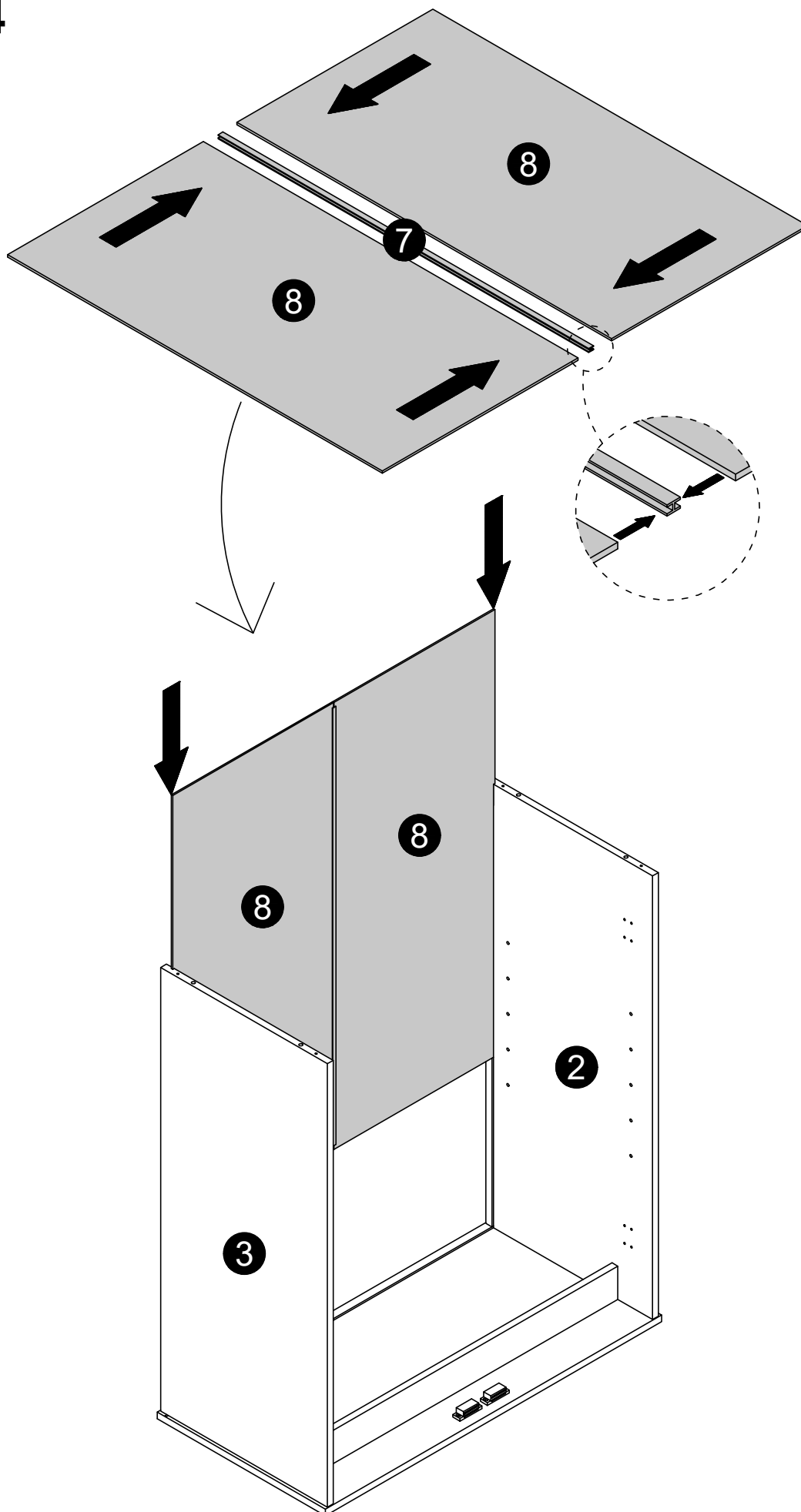



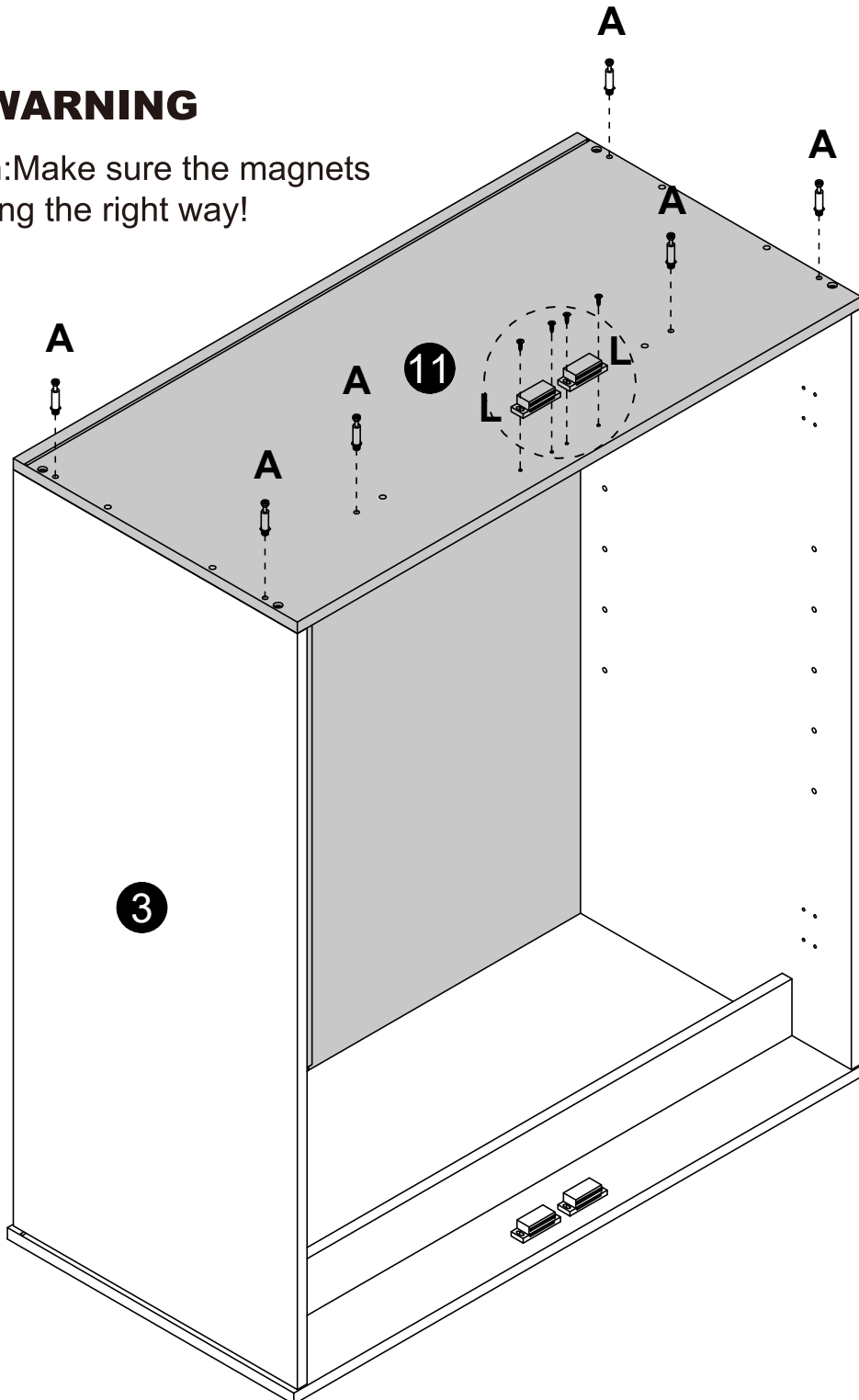

Step 6

WARNING

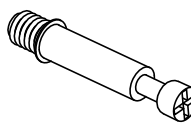

Caution: Make sure the magnets are facing the right way!

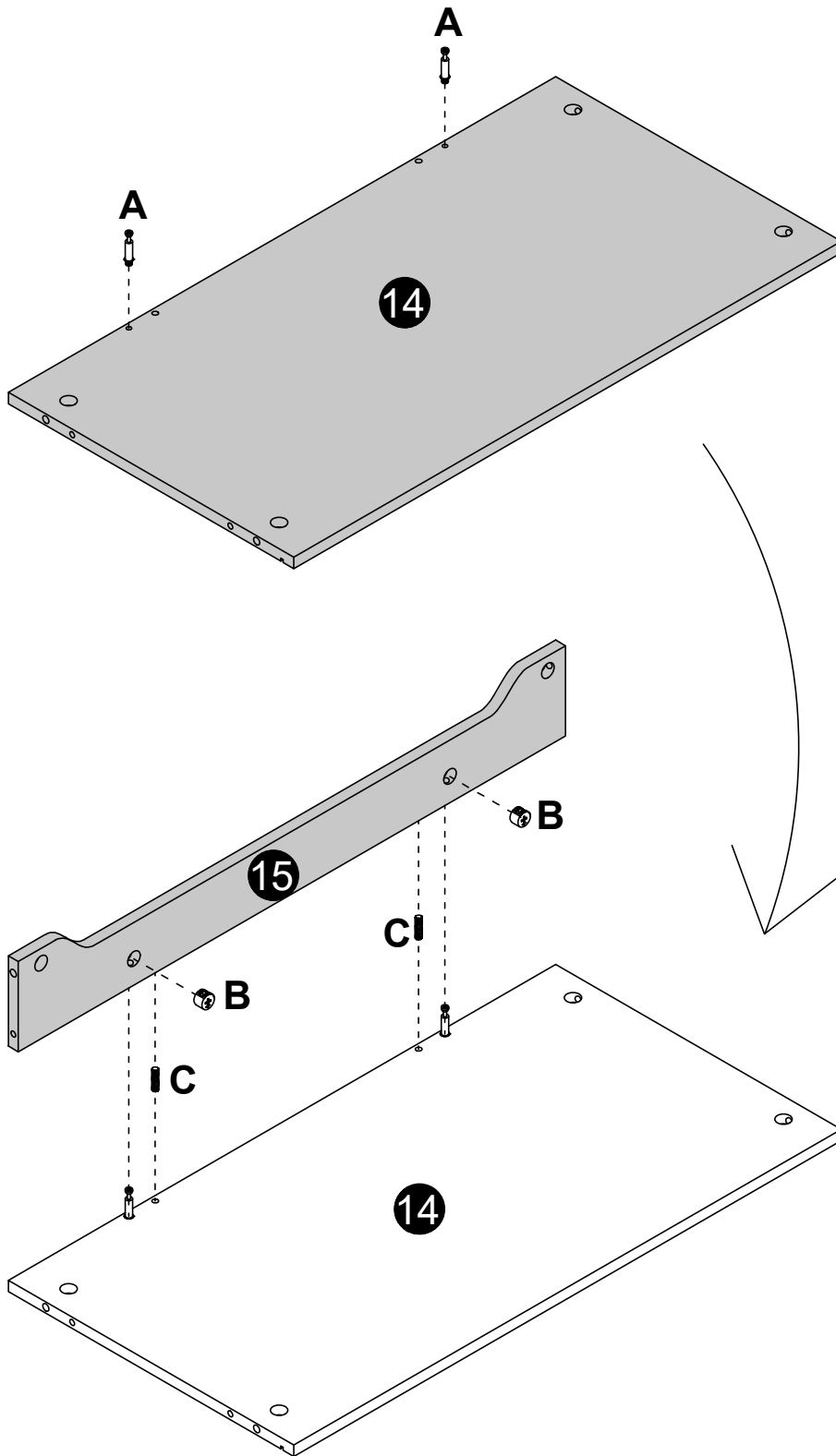

A	6x35mm	L	3x16mm
		L-1	L-2
			
			
	x6		x2

Step 7

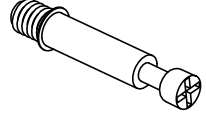
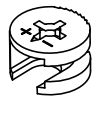

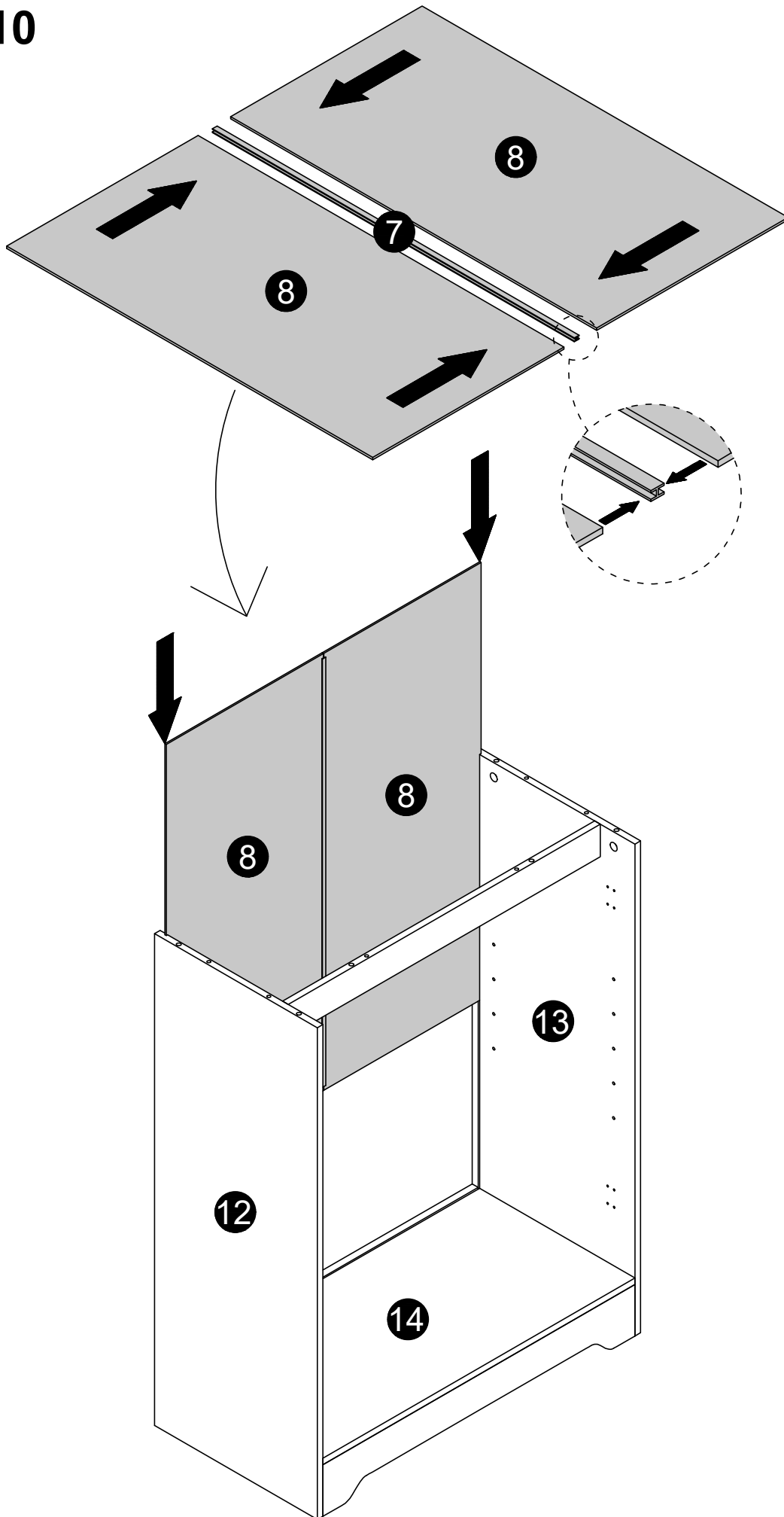

A	6x35mm	B	15x10mm	C	6x30mm
	x2		x2		x2

Step 10

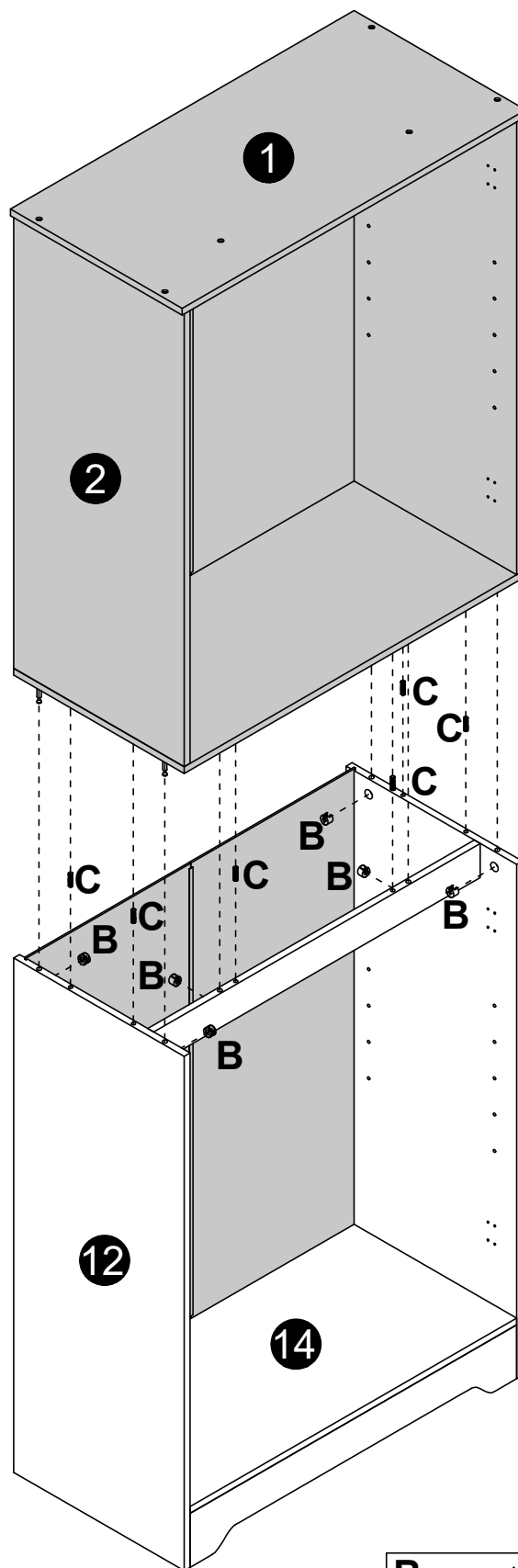
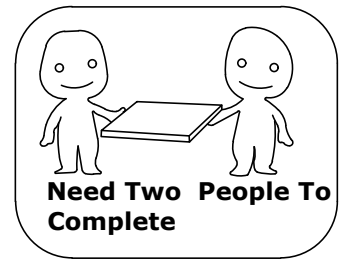

Step 11



B	15x10mm	C	6x30mm
			
	x6		x6



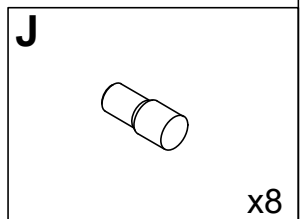
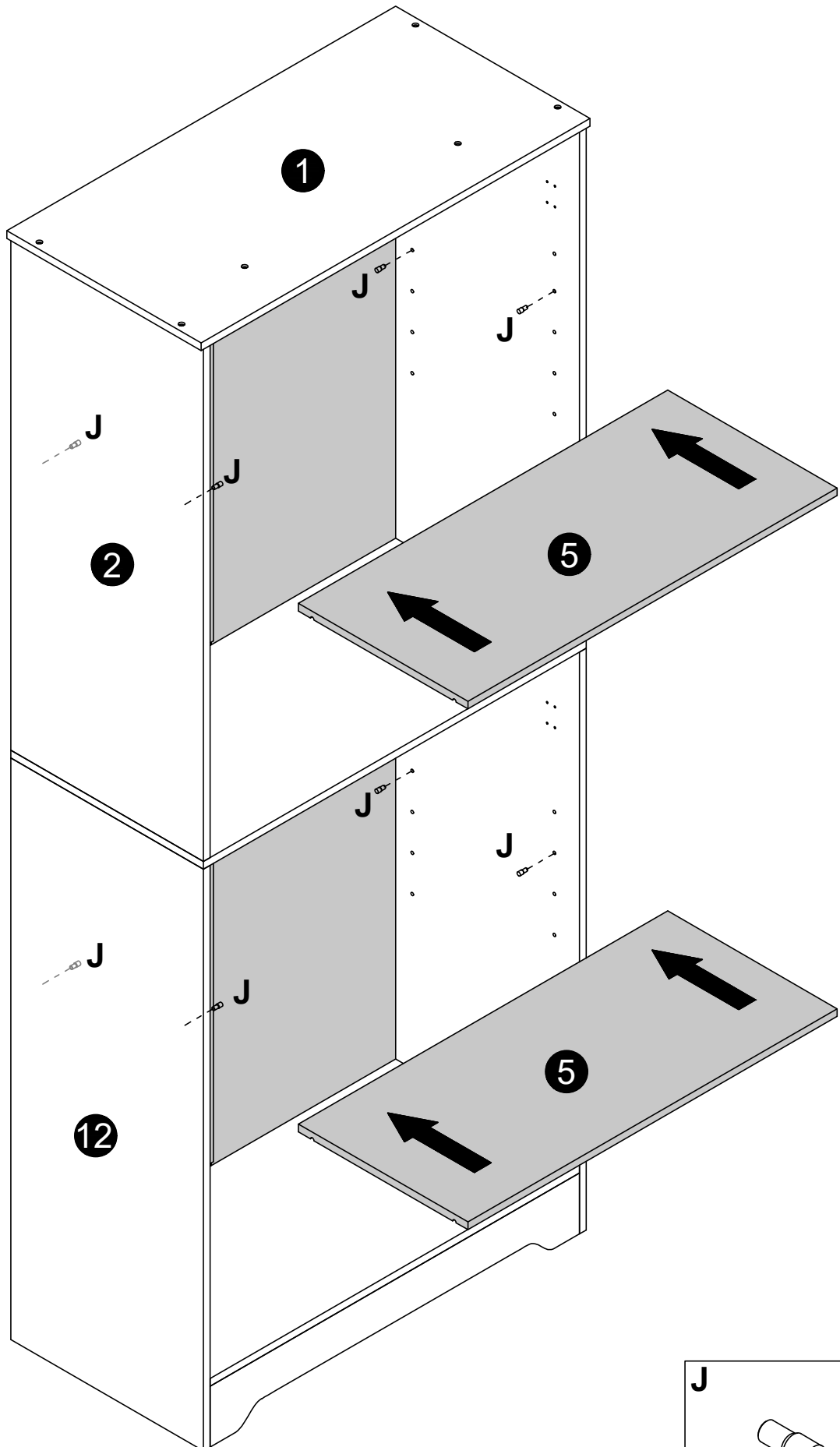

Step 12

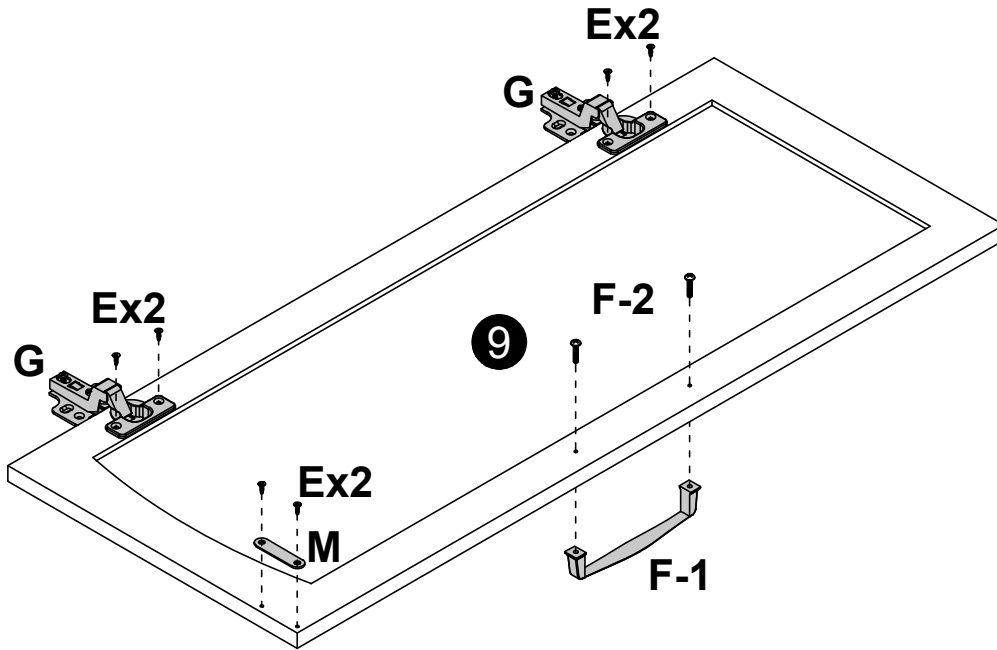

Step 13

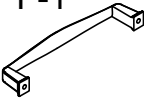
x2

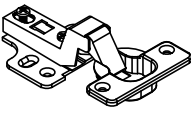



E 3.5x12mm  x12	F 4x18mm F-1  F-2  x2	G  x4	M  x2
--	---	--	--

Step 14

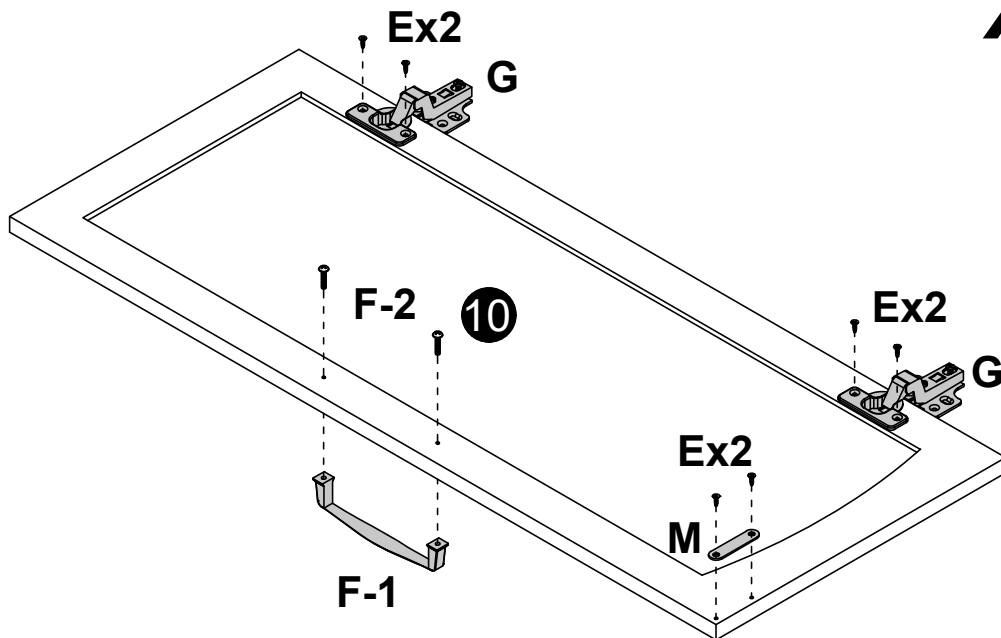
x2

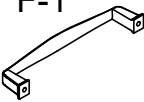

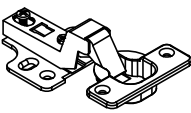
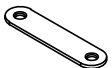
E 3.5x12mm  x12	F 4x18mm F-1  F-2  x2	G  x4	M  x2
---	---	---	---

Step 15

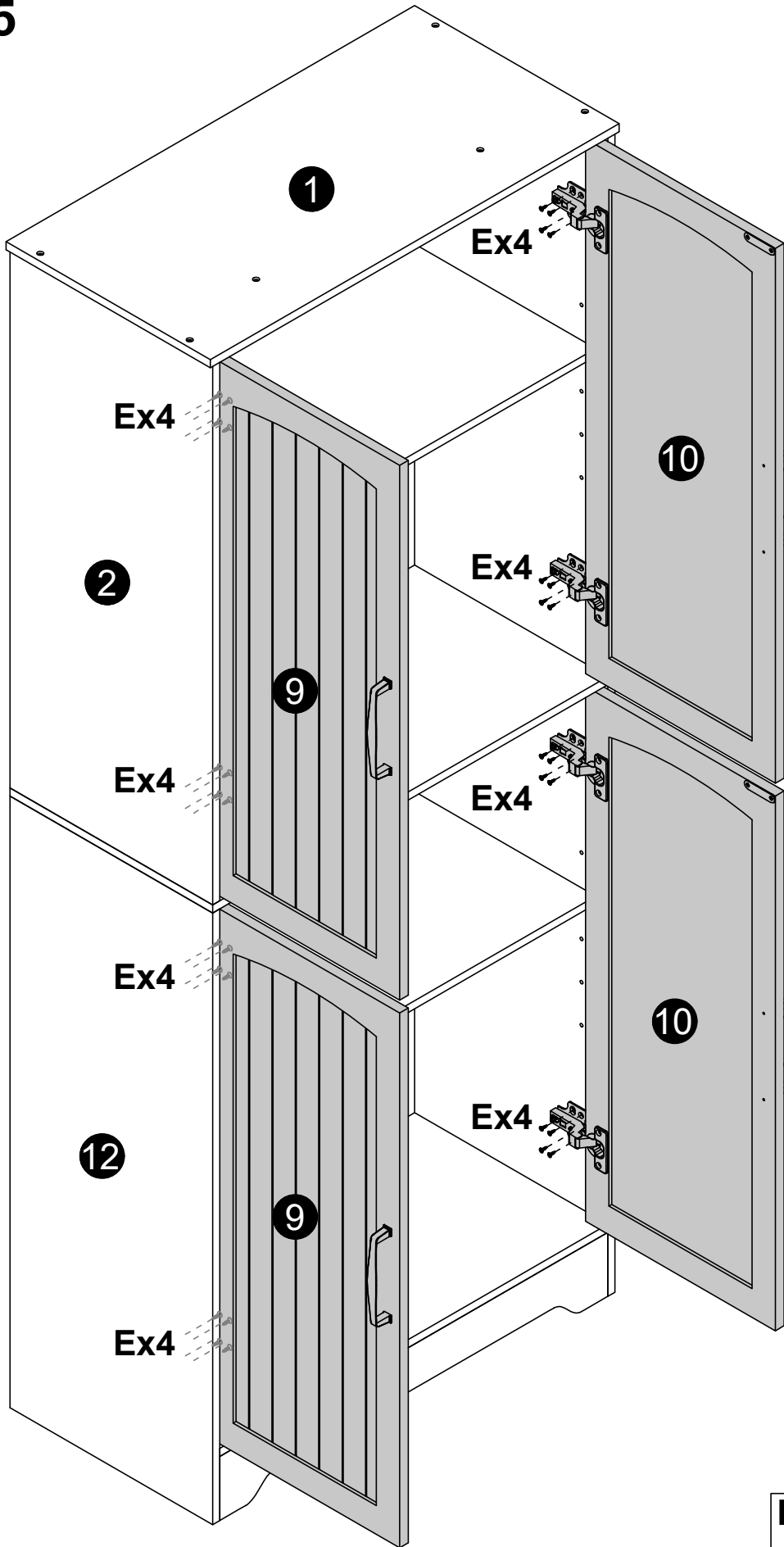

E	3.5x12mm
	
x32	

Step 16

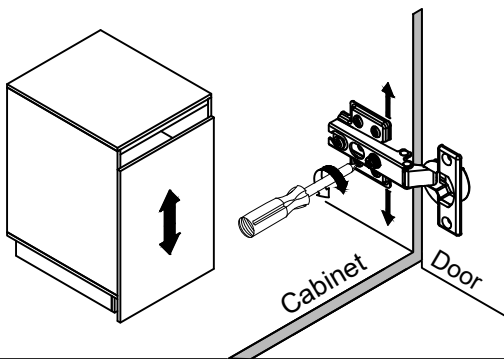
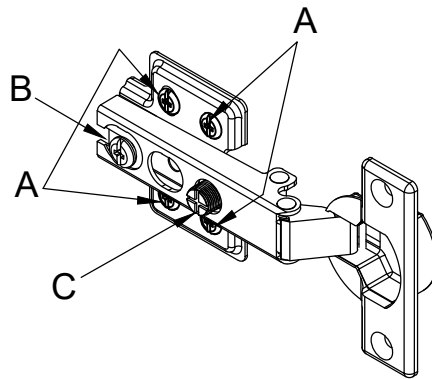

To adjust the vertical height.

Loosen the four screws "A" on both hinges. Two of them are usually in slotted holes which allows you to adjust up or down by a few mm. Then tighten back up.

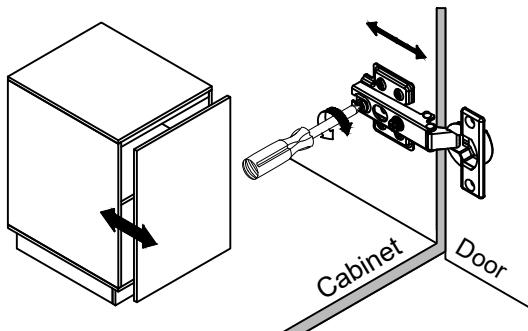

To adjust depth.

Loosen screw "B" and adjust door, if the door can not be adjusted, please loosen screw "C", then try again. Tighten screw "B" and "C".

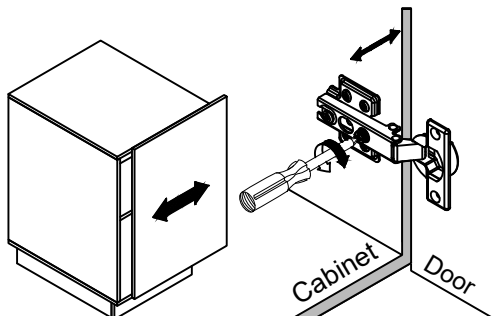



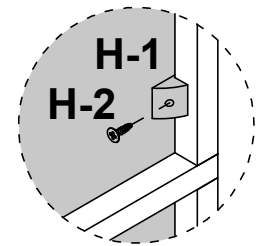
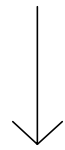
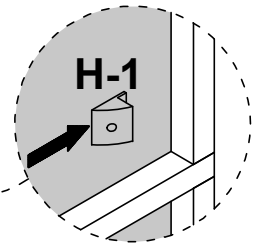
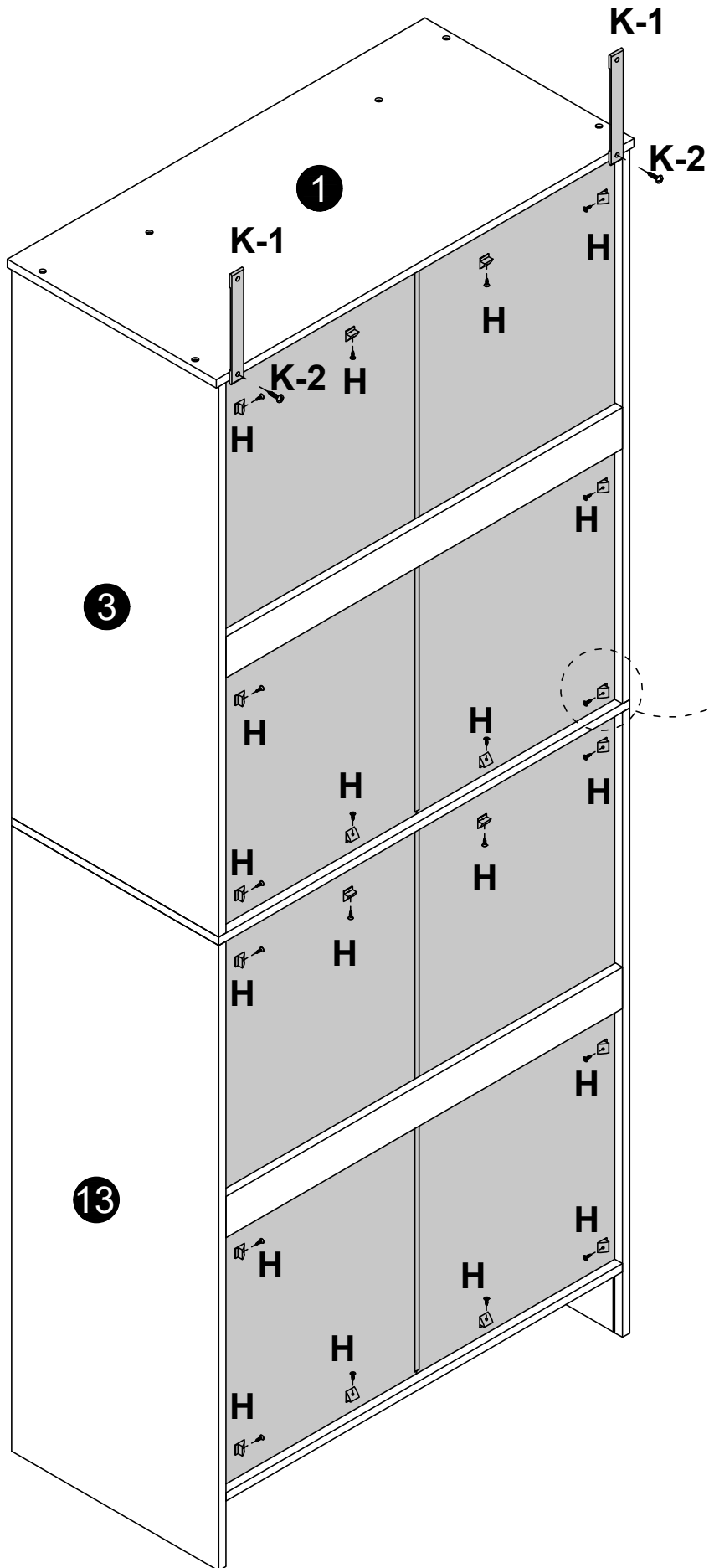

To adjust side ways.

Turning the screw "C" on BOTH hinges on each door.

Step 17

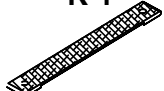

H	3x16mm
H-1	H-2
	
	x20
K	4x14mm
K-1	K-2
	
	x2

Step 18

