

BUNK BED

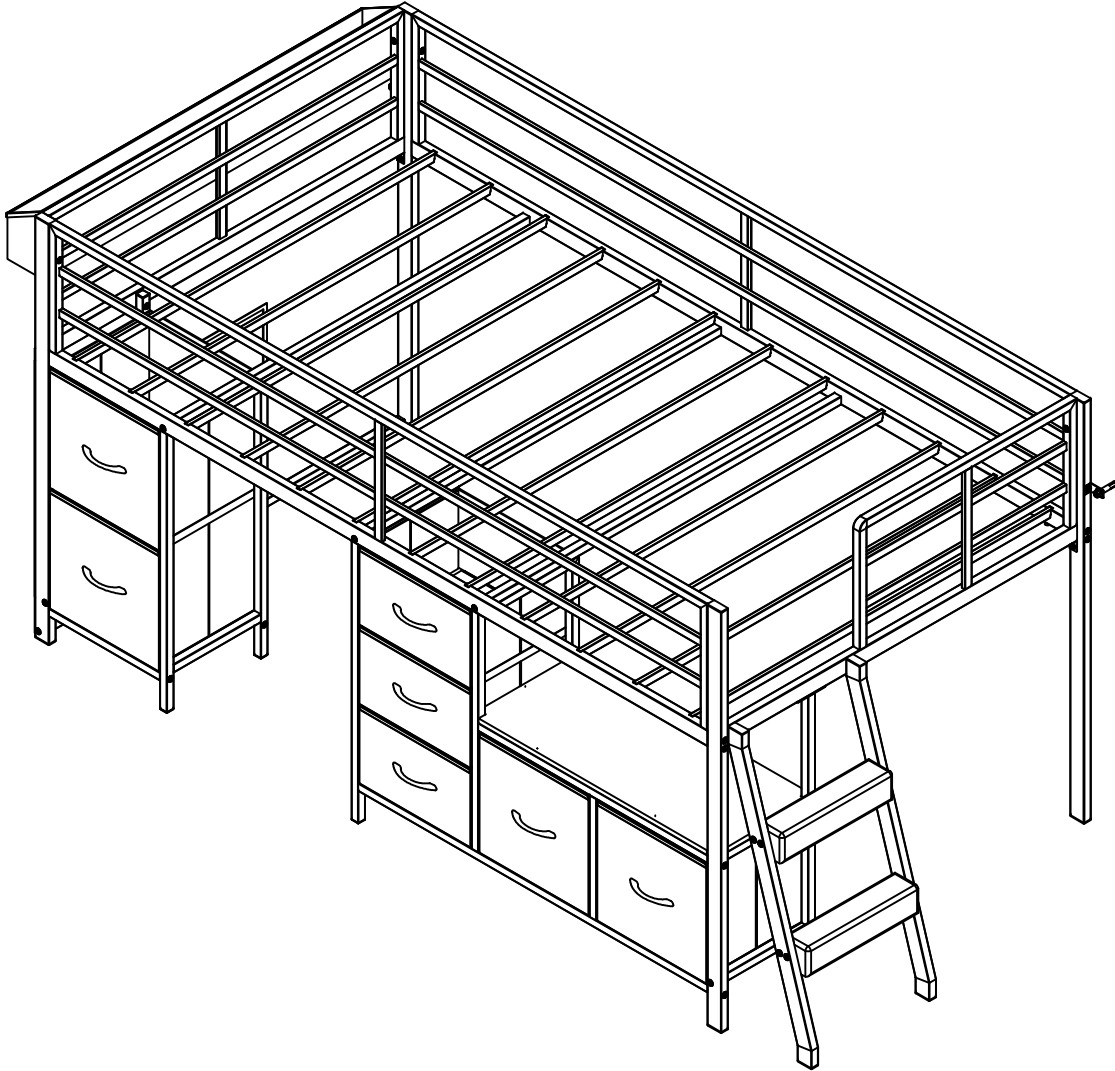



Model: C385-T-BK





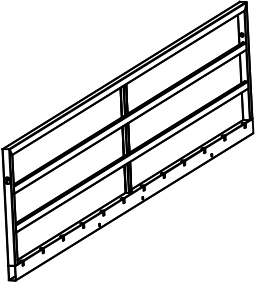
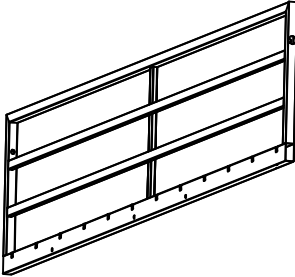
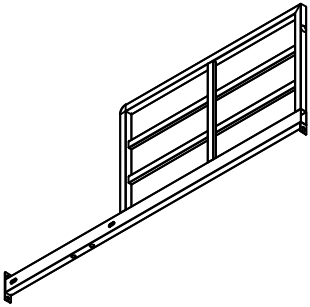
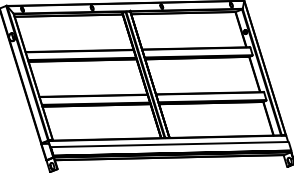
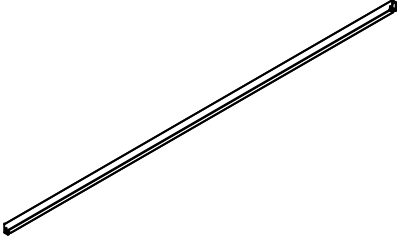
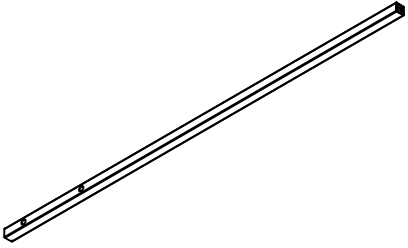
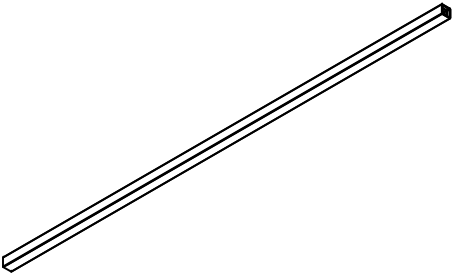

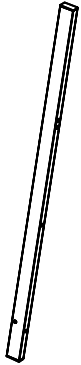
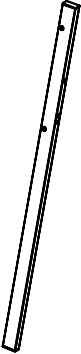
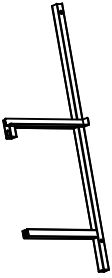
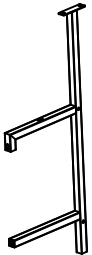
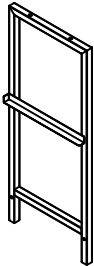
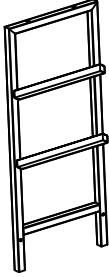
Please Scan the QR code to watch the tutorial video

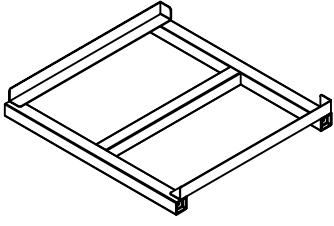
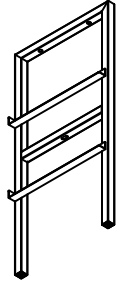
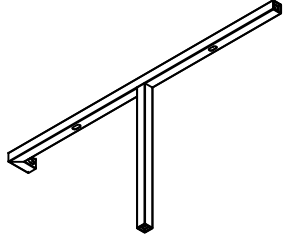
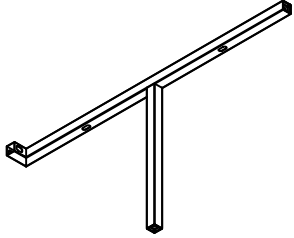
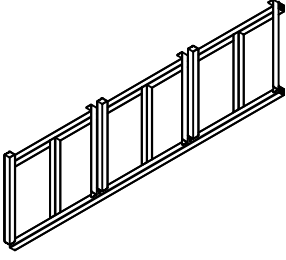
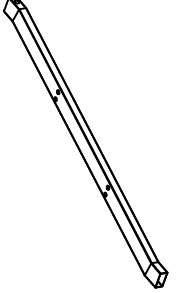
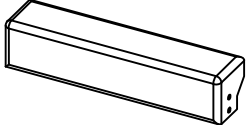
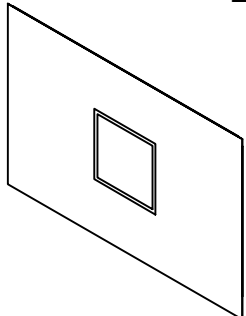
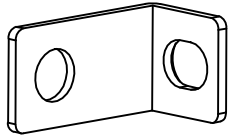
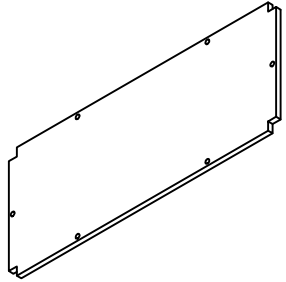
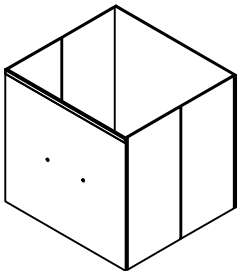
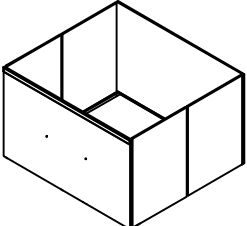
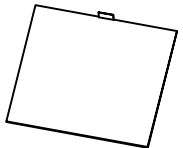
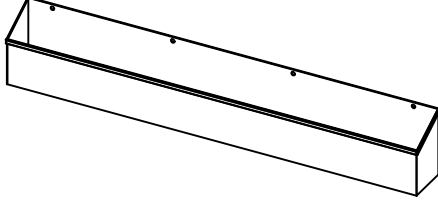
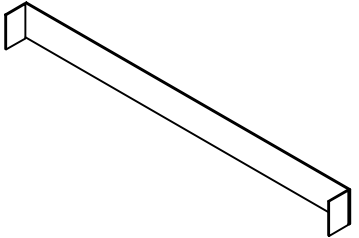

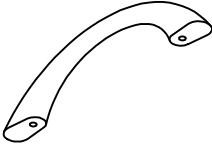
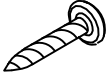
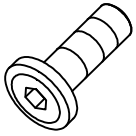
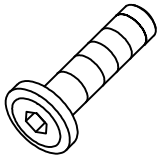
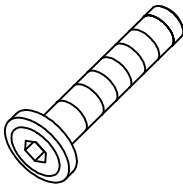
Parts List:

A 1pcs 	A1 1pcs 	B 1pcs 
B1 1pcs 	C 12pcs 	D 3pcs 
E 1pcs 	F 1pcs 	F1 1pcs 
F2 1pcs 	F3 1pcs 	G 1pcs 
G1 1pcs 	H 1pcs 	H1 1pcs 

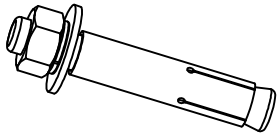
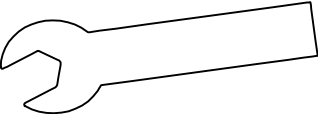
<p>I 1pcs</p> 	<p>J 1pcs</p> 	<p>K 1pcs</p> 
<p>K1 1pcs</p> 	<p>L 1pcs</p> 	<p>M 2pcs</p> 
<p>N 2pcs</p> 	<p>O 1pcs</p> 	<p>P 2pcs</p> 
<p>R 1pcs</p> 	<p>S 4pcs</p> 	<p>S1 3pcs</p> 
<p>T 7pcs</p> 	<p>U 1pcs</p> 	<p>U1 1pcs</p> 

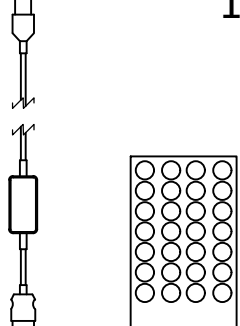
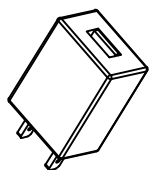
<p>V 7pcs</p> 	<p>V1 14pcs</p>  <p>M4x12mm</p>	<p>W 13pcs</p>  <p>M8x15mm</p>
<p>W1 28pcs</p>  <p>M8x35mm</p>	<p>W2 8pcs</p>  <p>M8x60mm</p>	<p>W3 6pcs</p>  <p>M6x30mm</p>
<p>W4 22pcs</p>  <p>M6x35mm</p>	<p>W5 2pcs</p>  <p>M6x55mm</p>	<p>X 2pcs</p>  <p>M8x60mm</p>
<p>Y 1pcs</p> 	<p>Y1 1pcs</p> 	<p>Z 1pcs</p> 
<p>Z1 1pcs</p> 		

ASSEMBLY

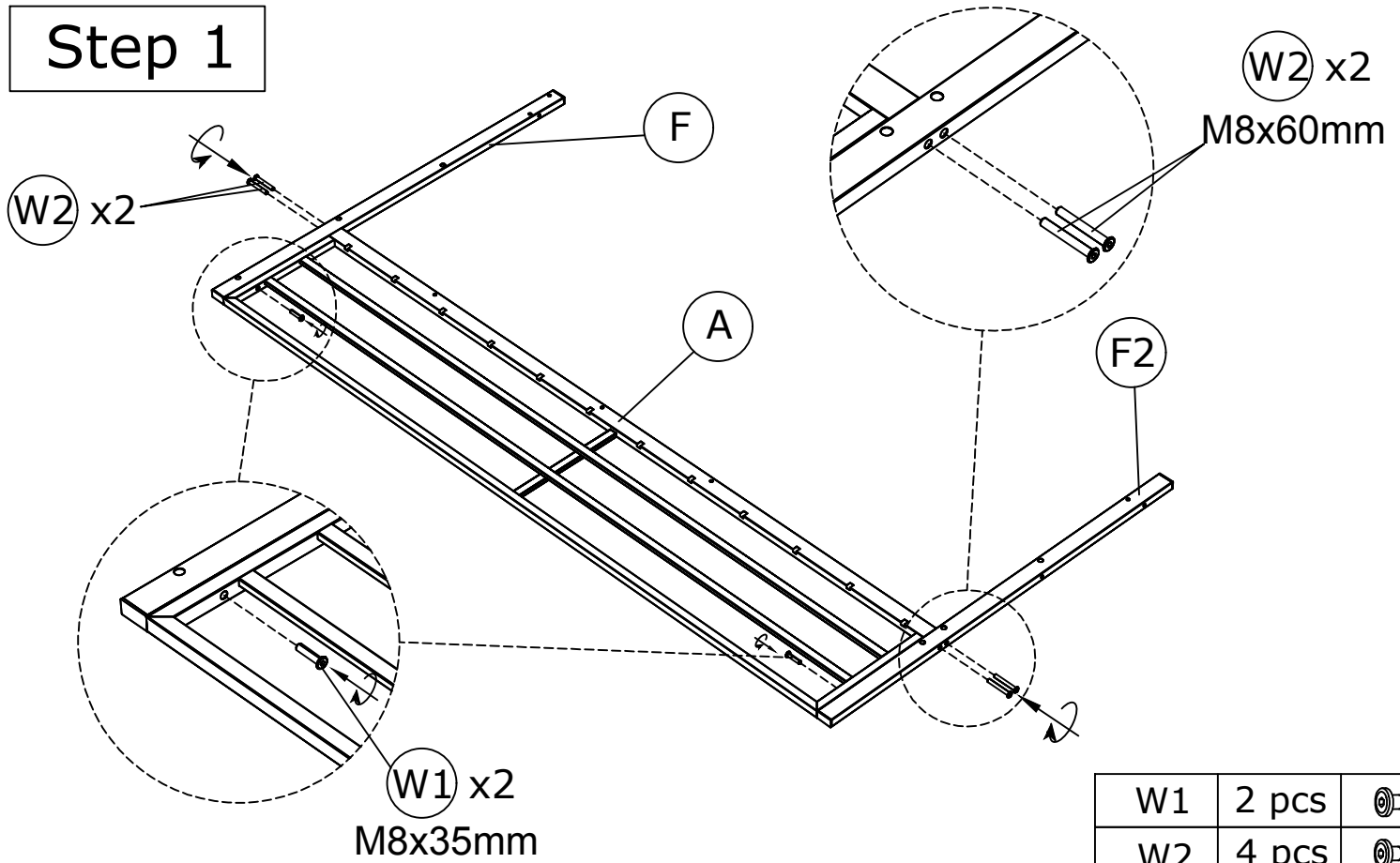

Step 1

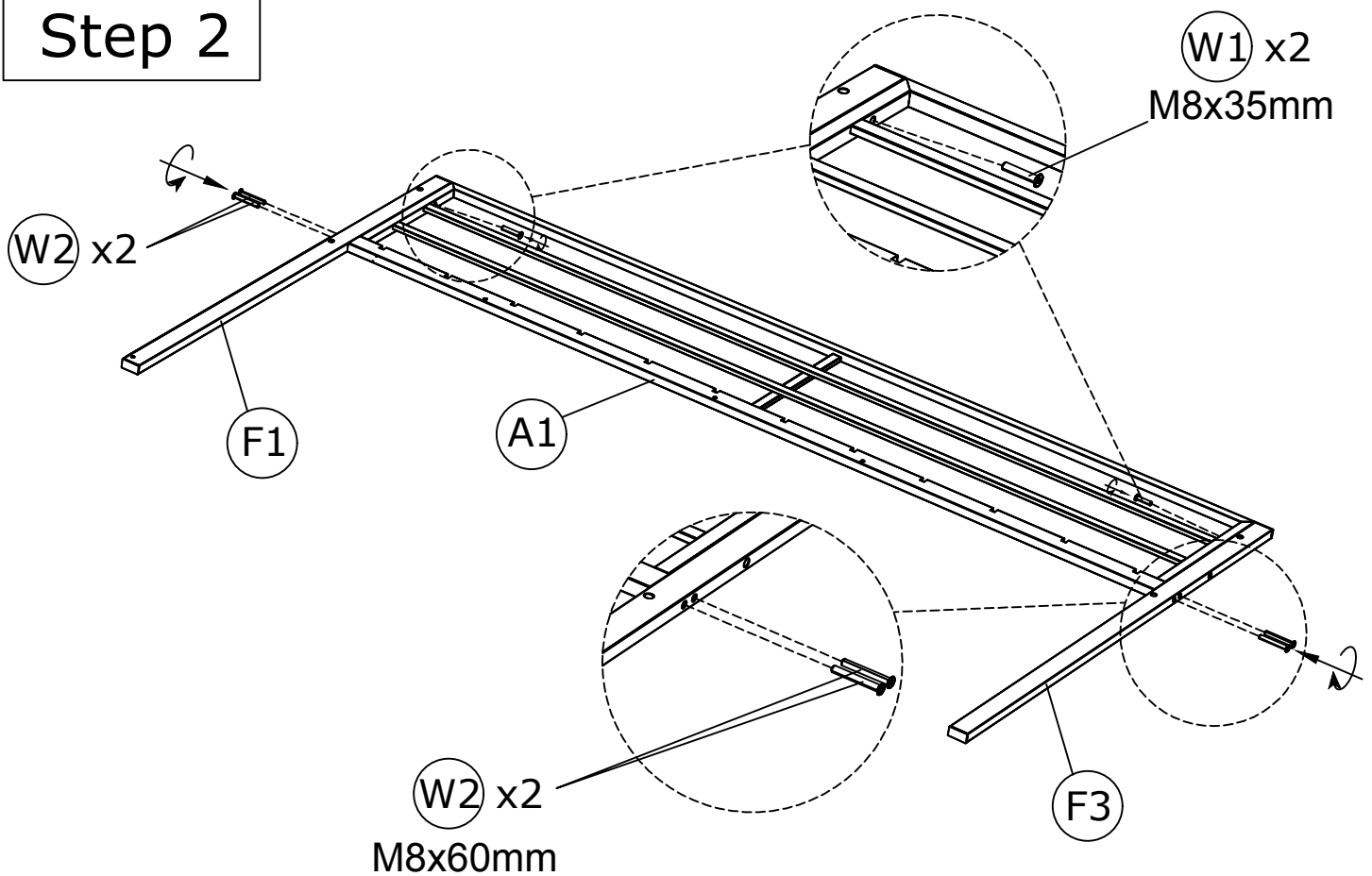

Step 2



5

W1	2 pcs	
W2	4 pcs	

Step 3

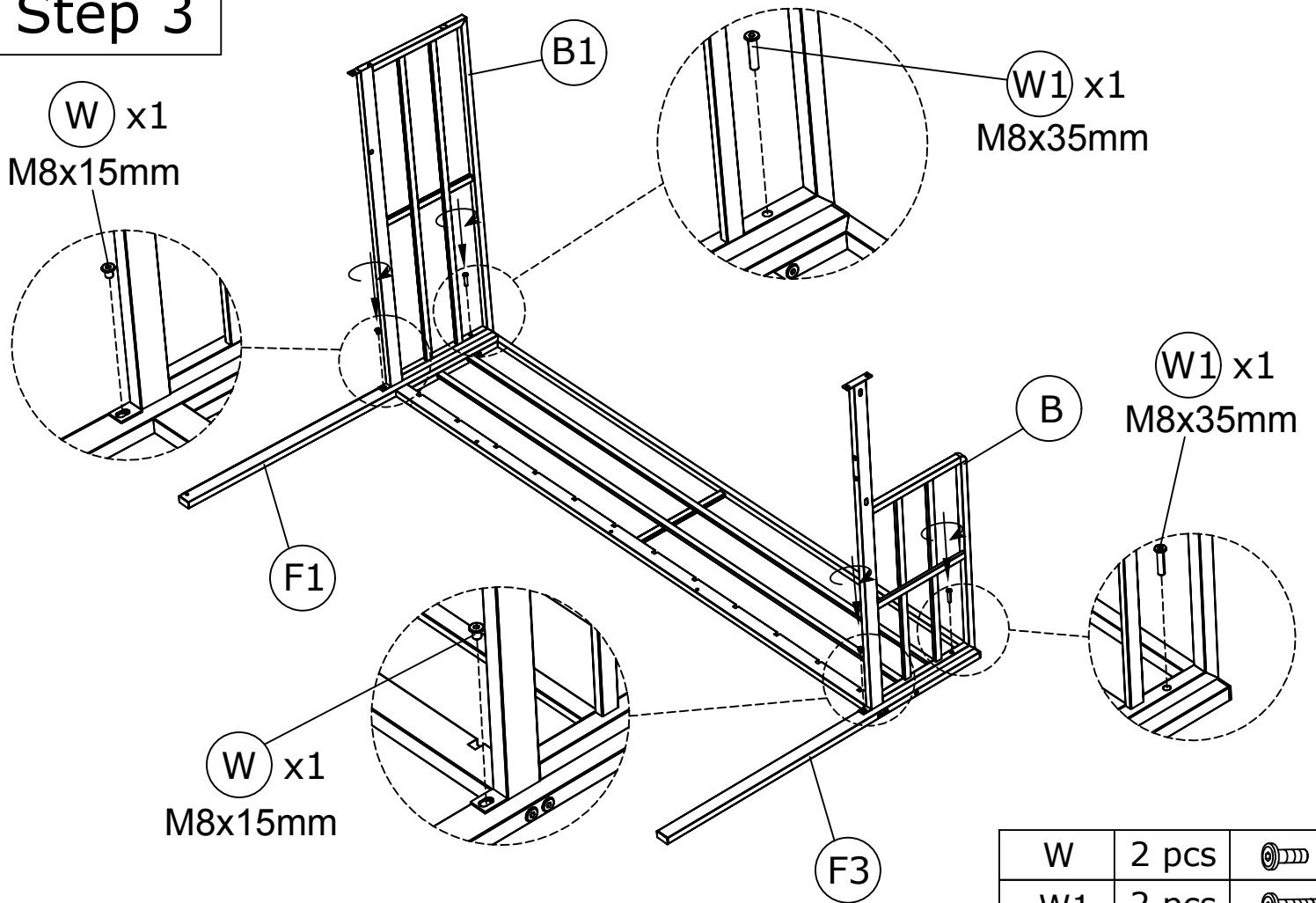

Step 4

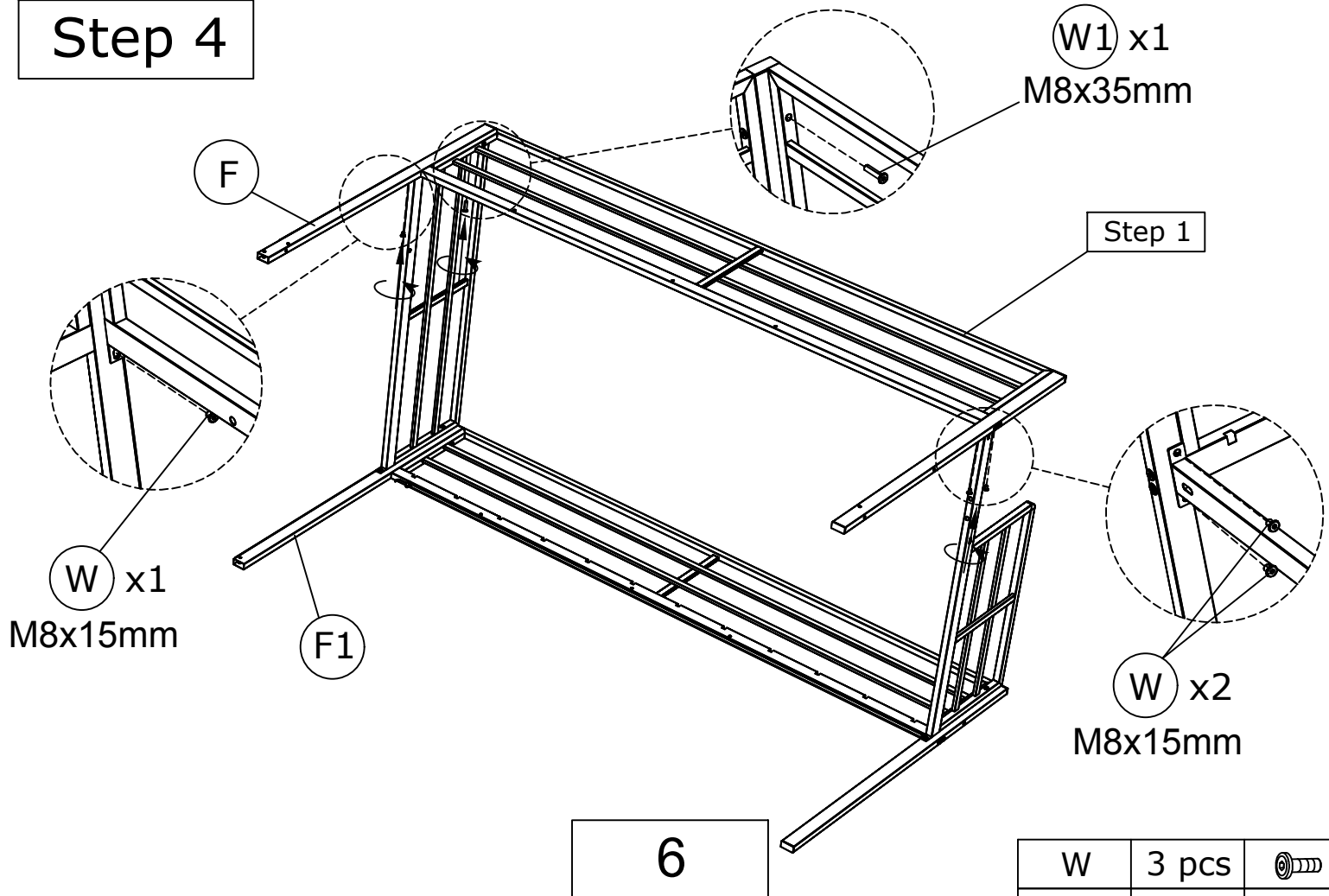

Step 5

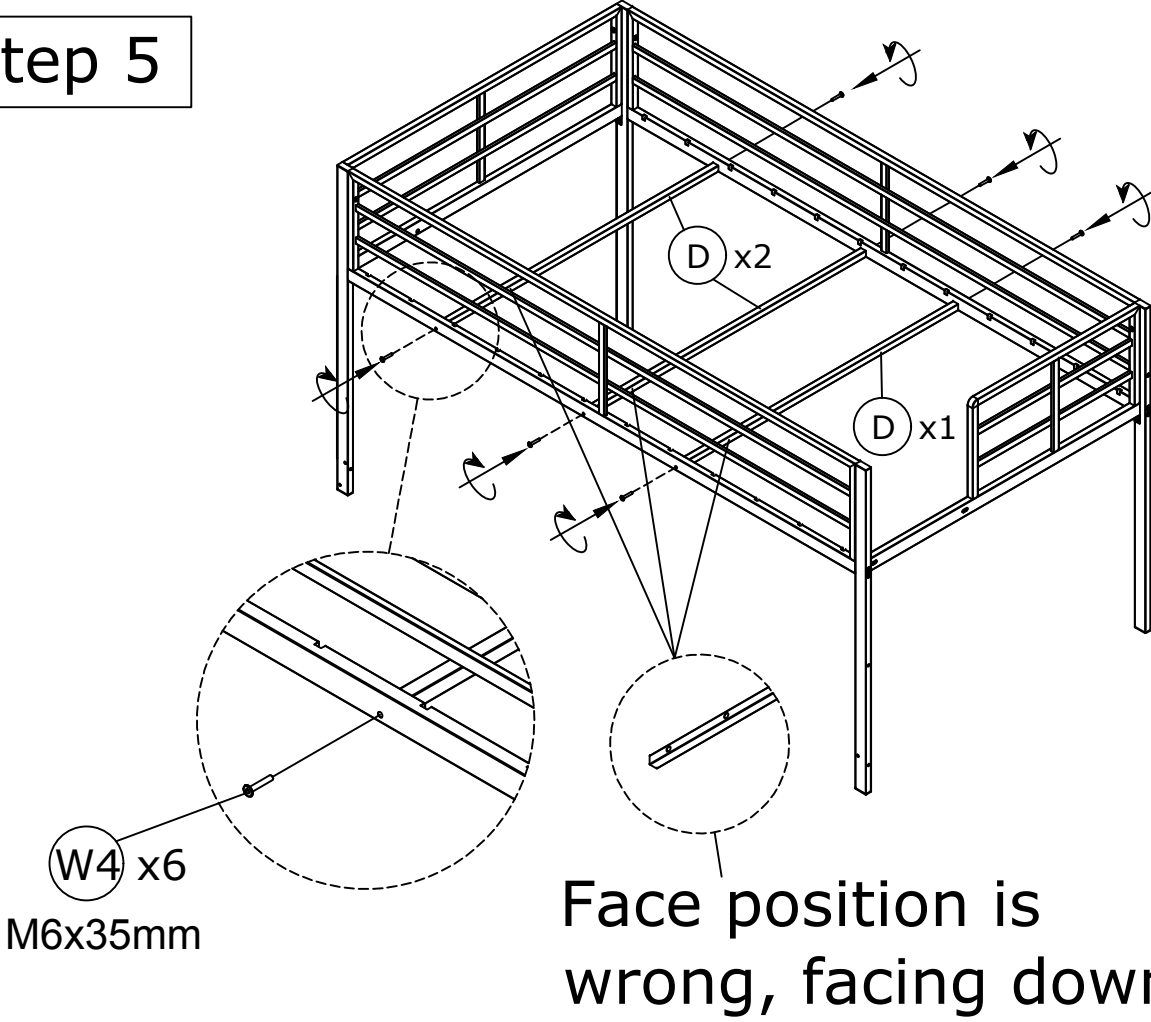

W4	6 pcs	
----	-------	---

Step 6

Drawer rail direction

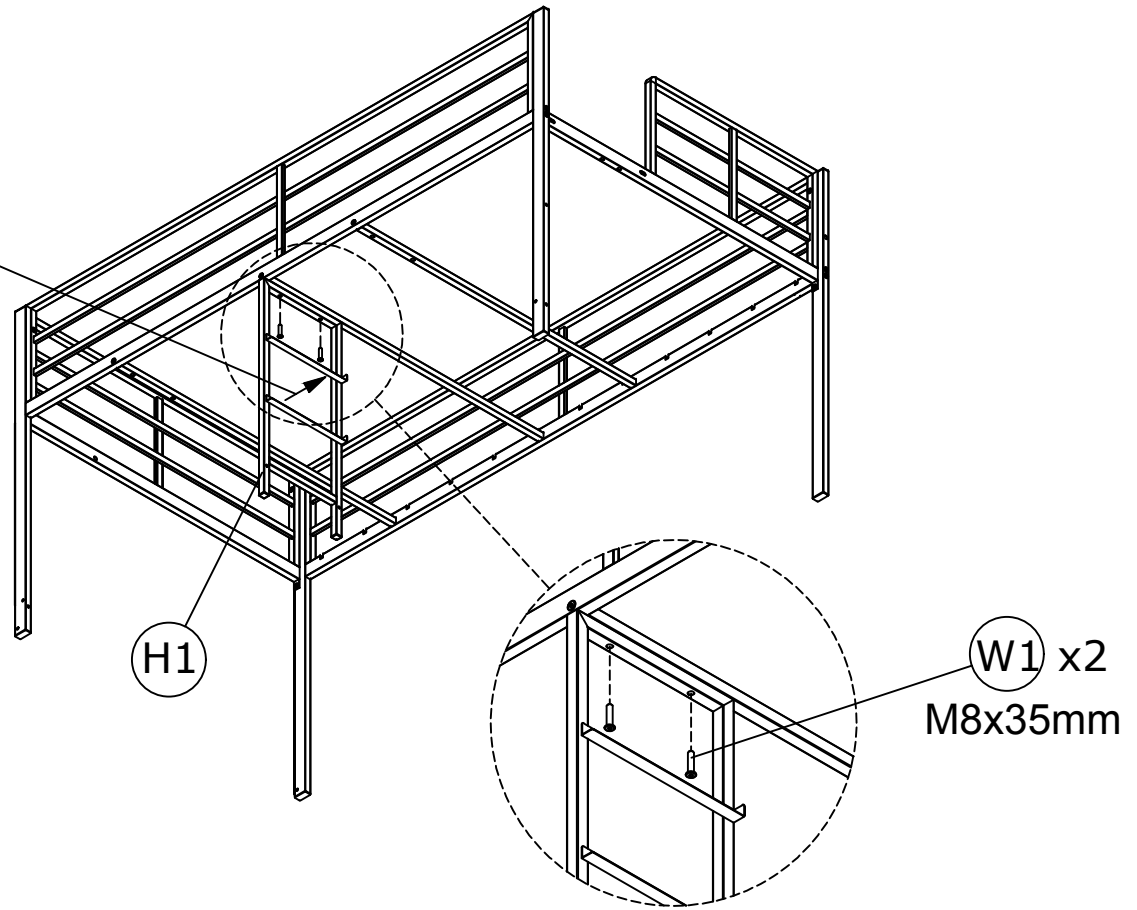



7

W1	2 pcs	
----	-------	---

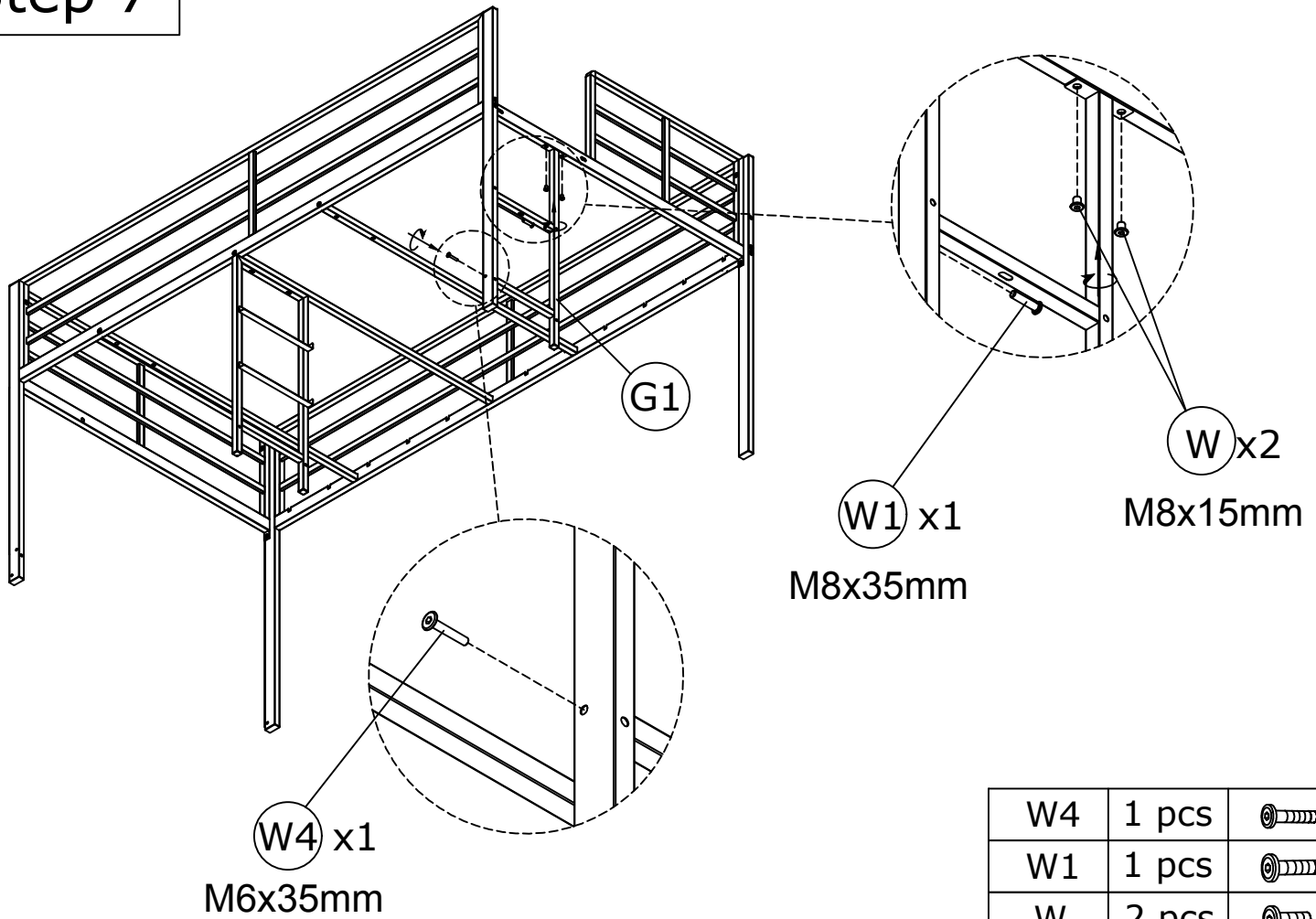
Step 7



W4	1 pcs	
W1	1 pcs	
W	2 pcs	

Step 8

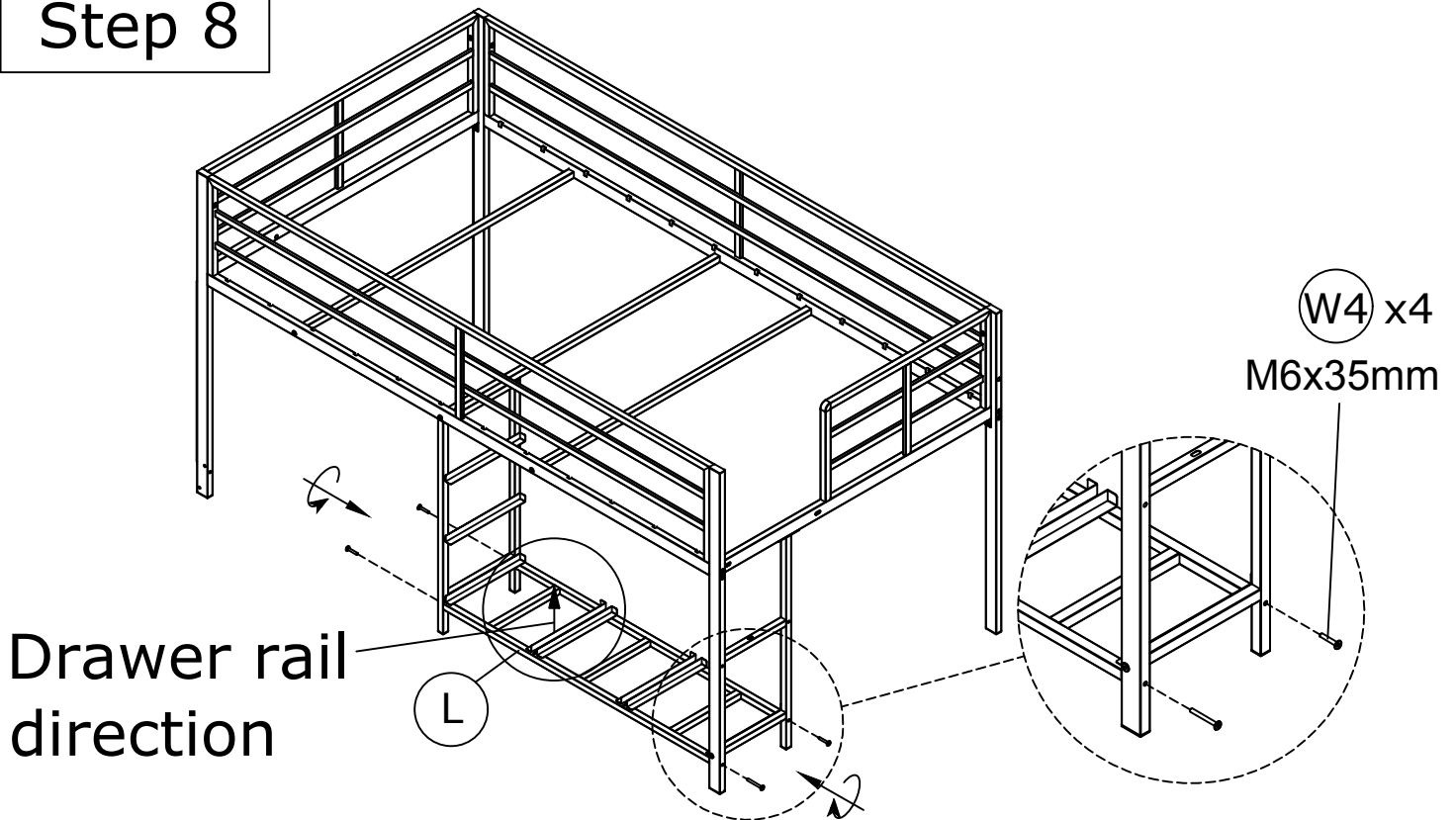

8

W4	4 pcs	
----	-------	---

Step 9

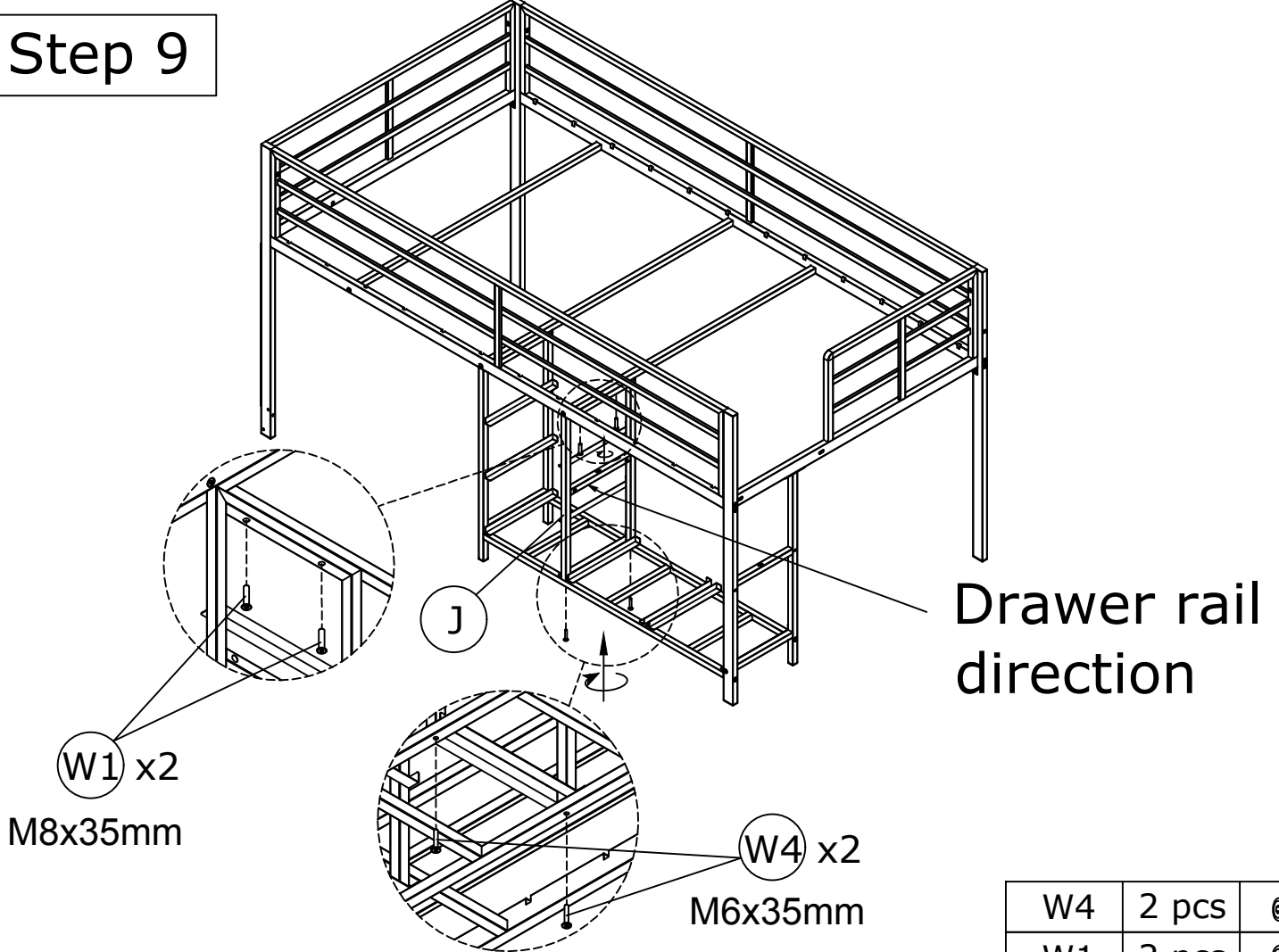

Step 10

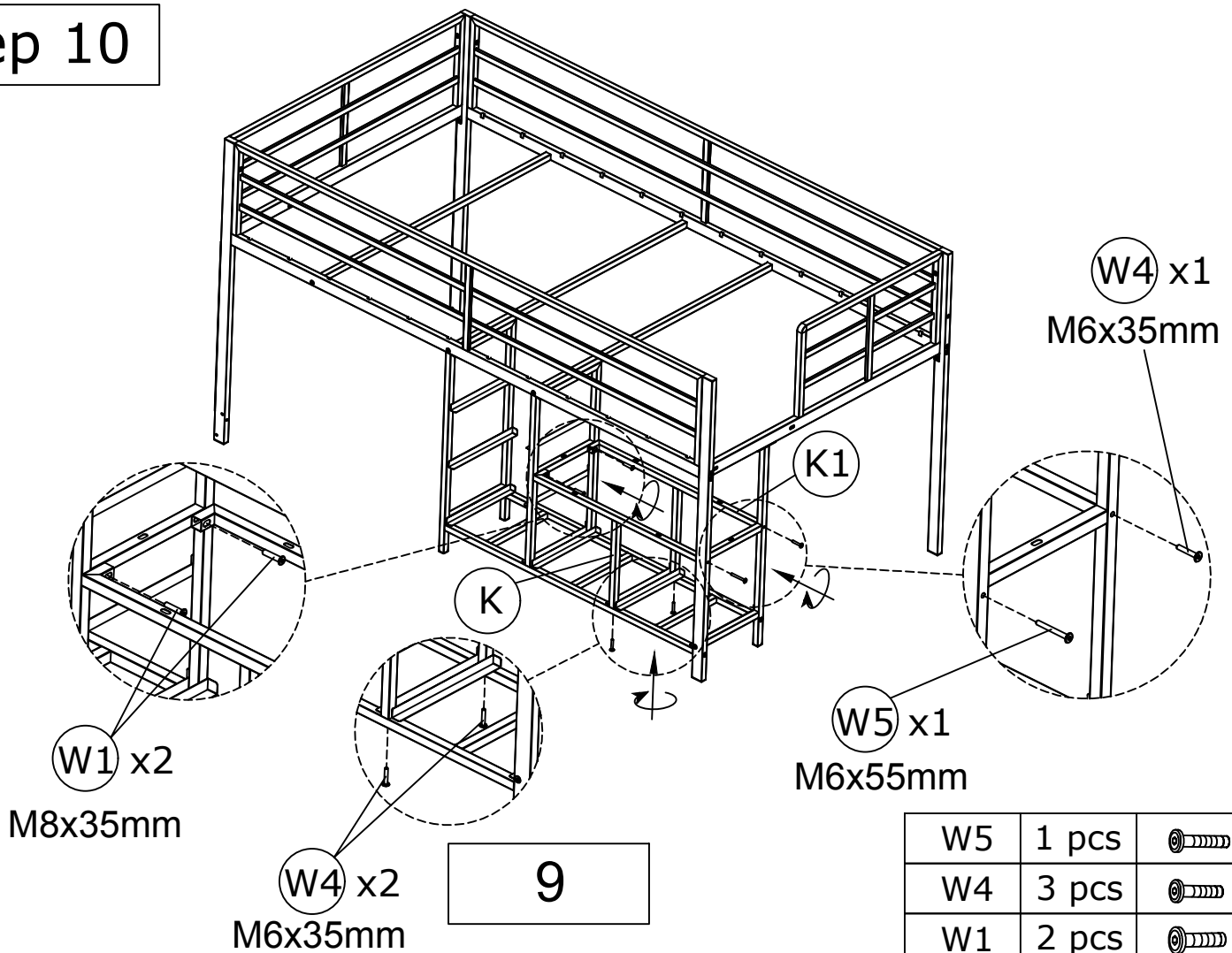

Step 11

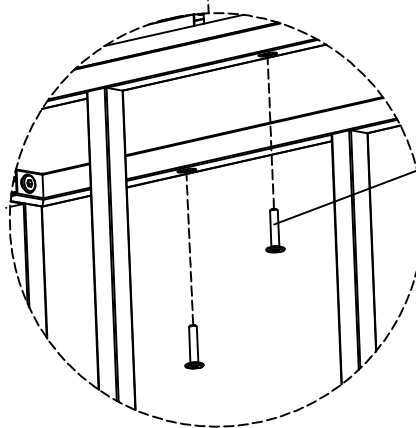
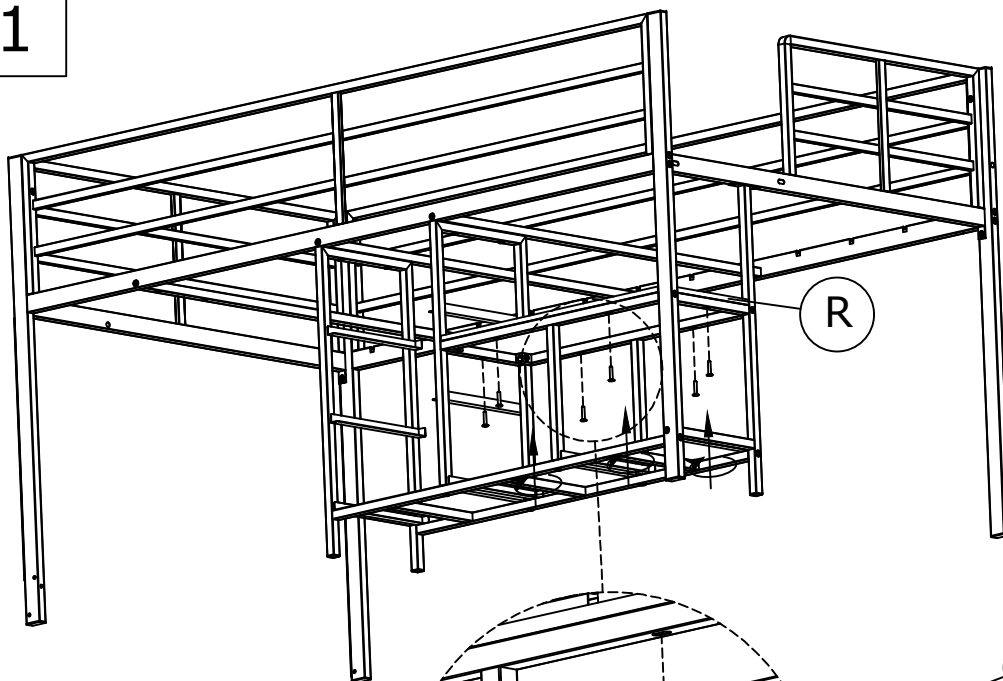

W3 x6
M6x30mm

W3 6 pcs 

Step 12

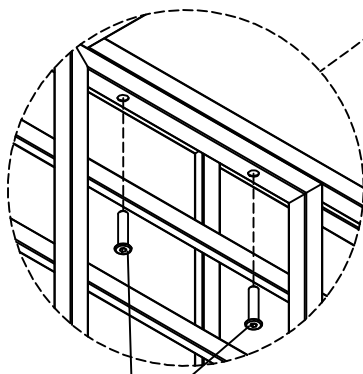
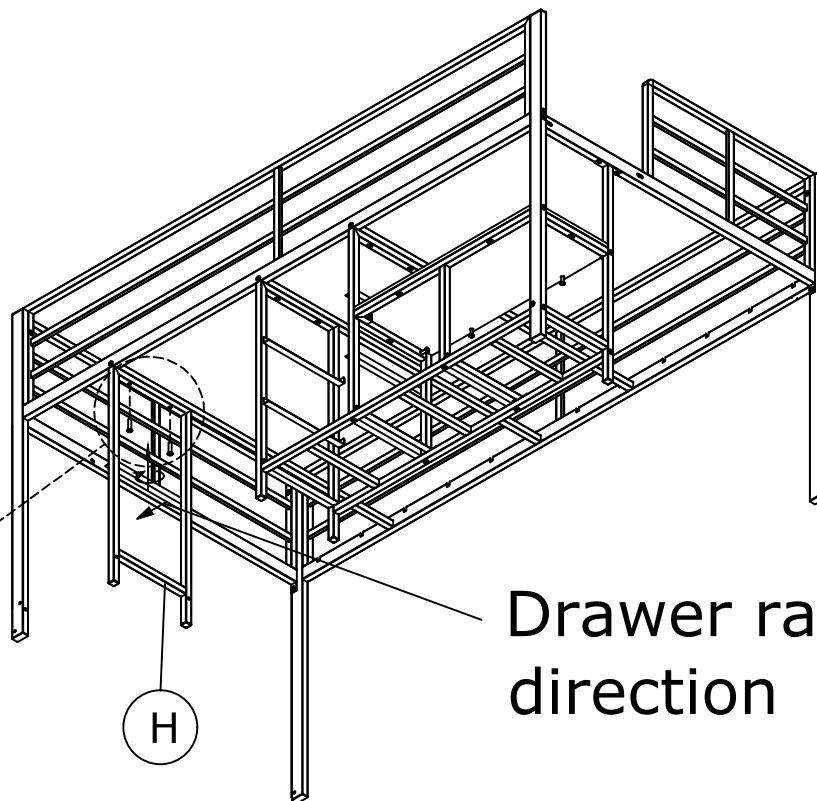

W1 x2
M8x35mm

Drawer rail
direction

10

W1 2 pcs 

Step 13

W1 x1
M8x35mm

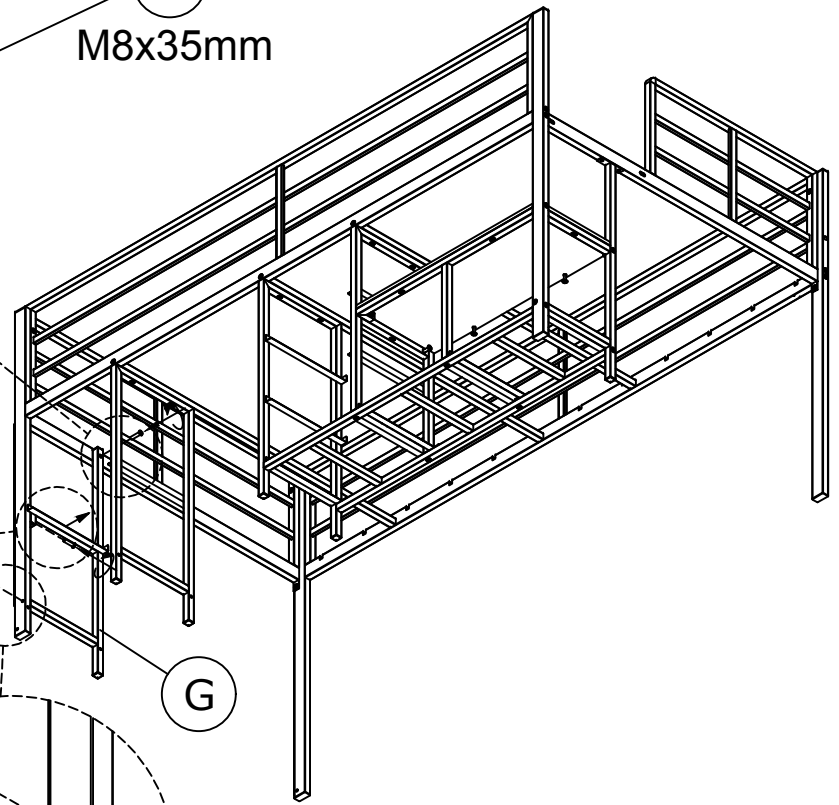
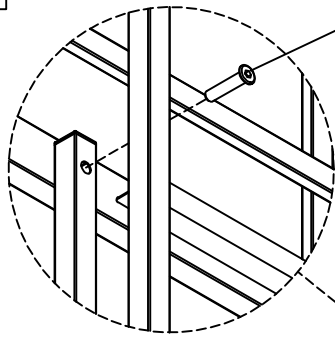

Drawer rail direction

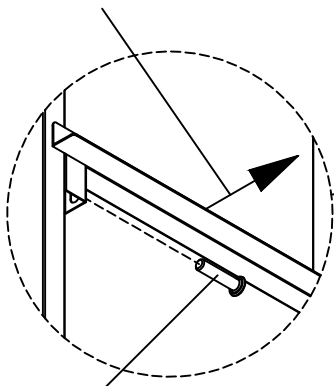

W1 x1
M8x35mm

W4 x1
M6x35mm

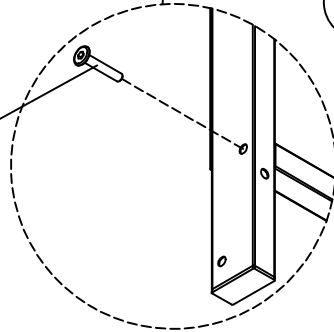

W4	1 pcs	
W1	2 pcs	

Step 14

Drawer rail direction

W4 x1
M6x35mm

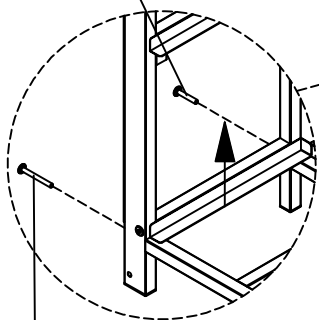

I

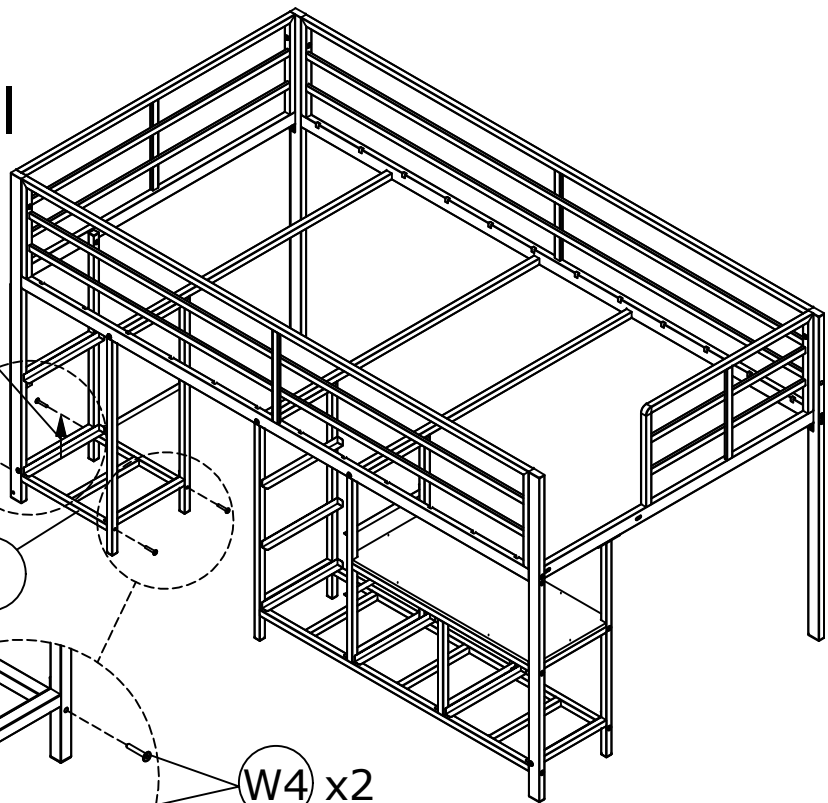

W5 x1
M6x55mm

W4 x2
M6x35mm

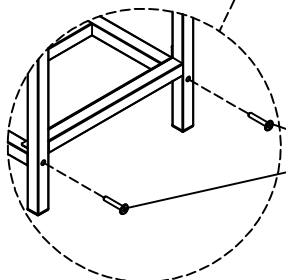

11

W4	3 pcs	
W5	1 pcs	

Step 15

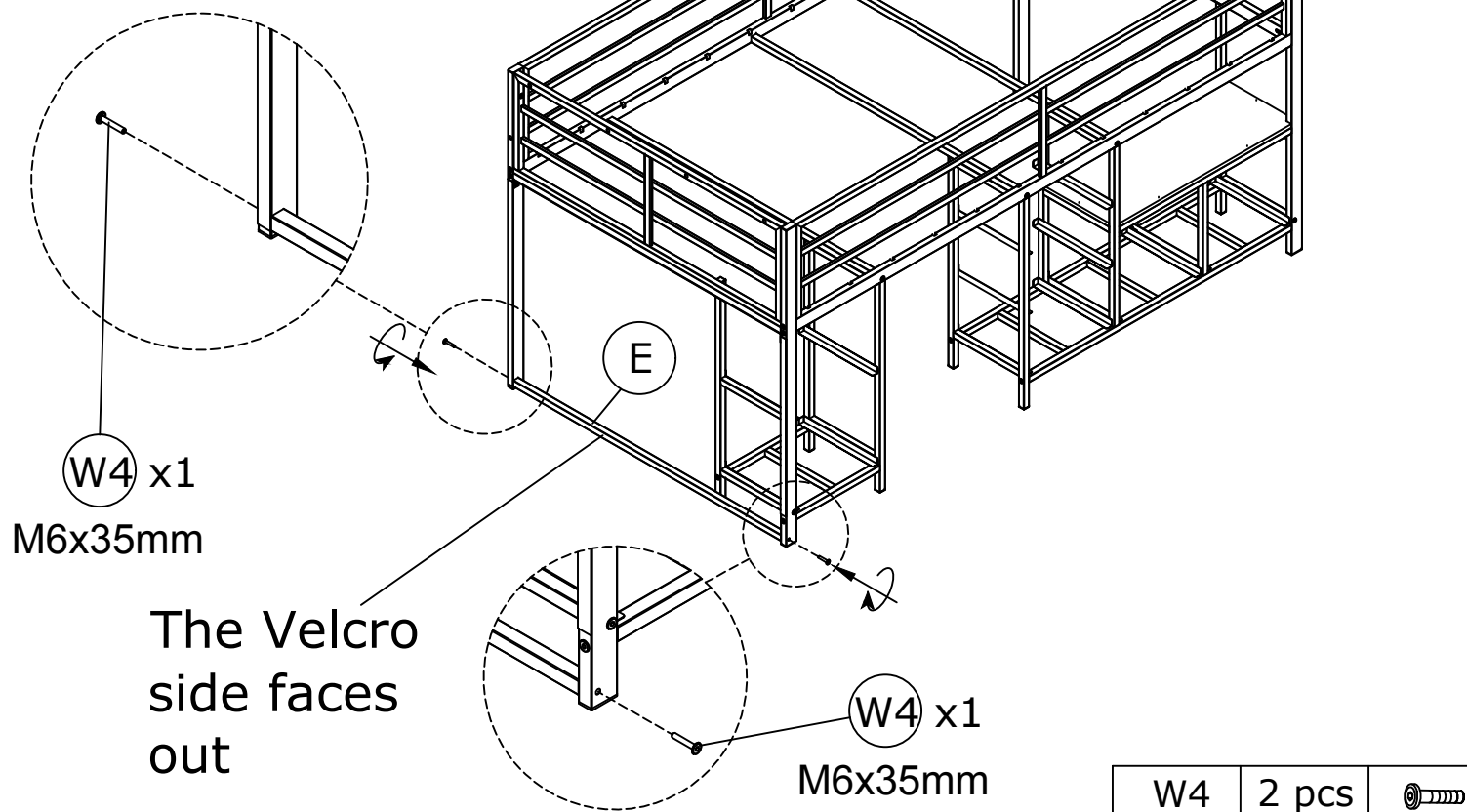

Step 16

Attach the Velcro (Hook) side to the Velcro (Loop) side on the bed frame

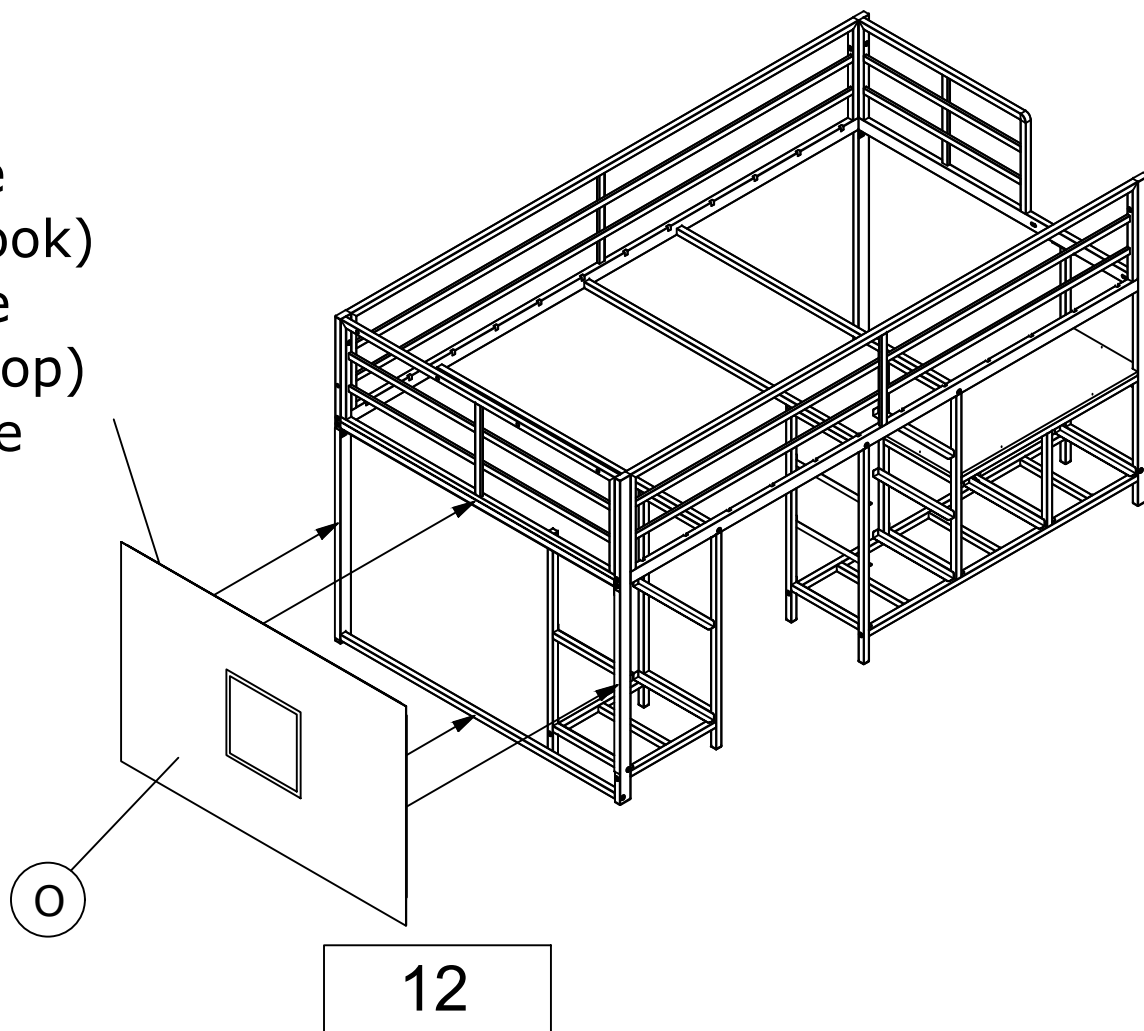

Step 17

Open part U
and put part
U1 in

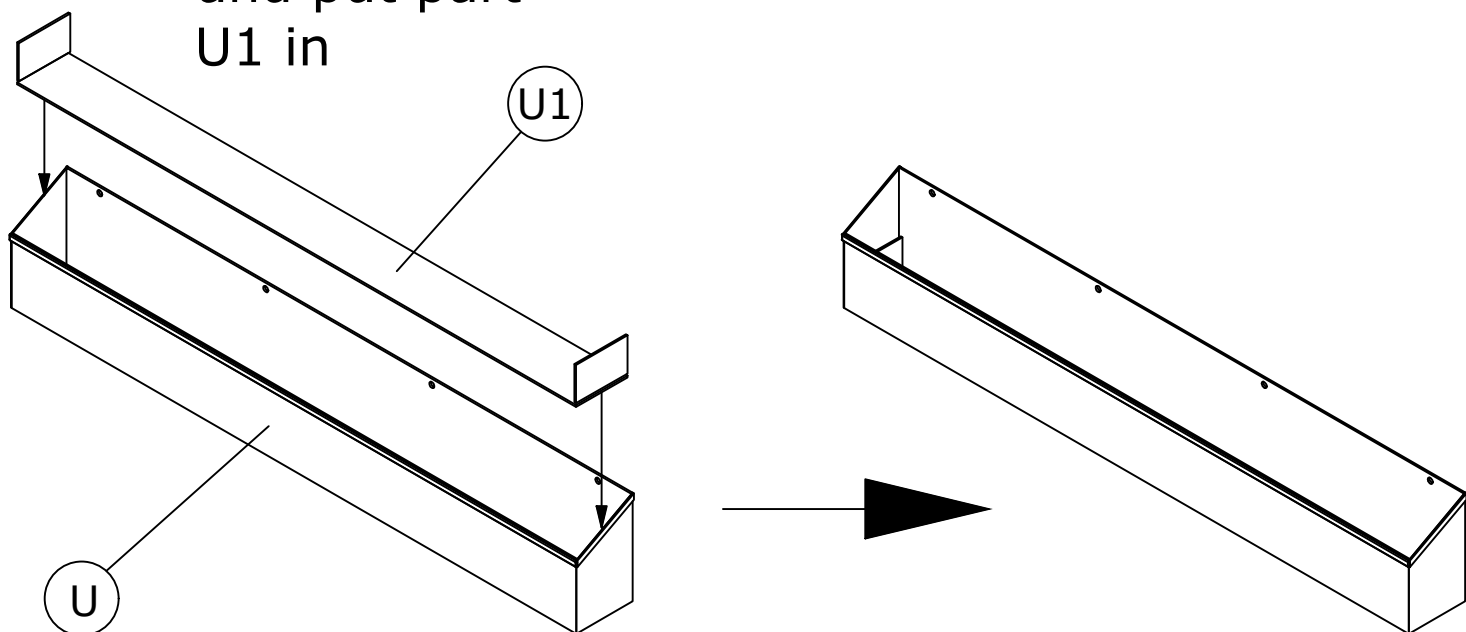

Step 18

(W) x4
M8x15mm

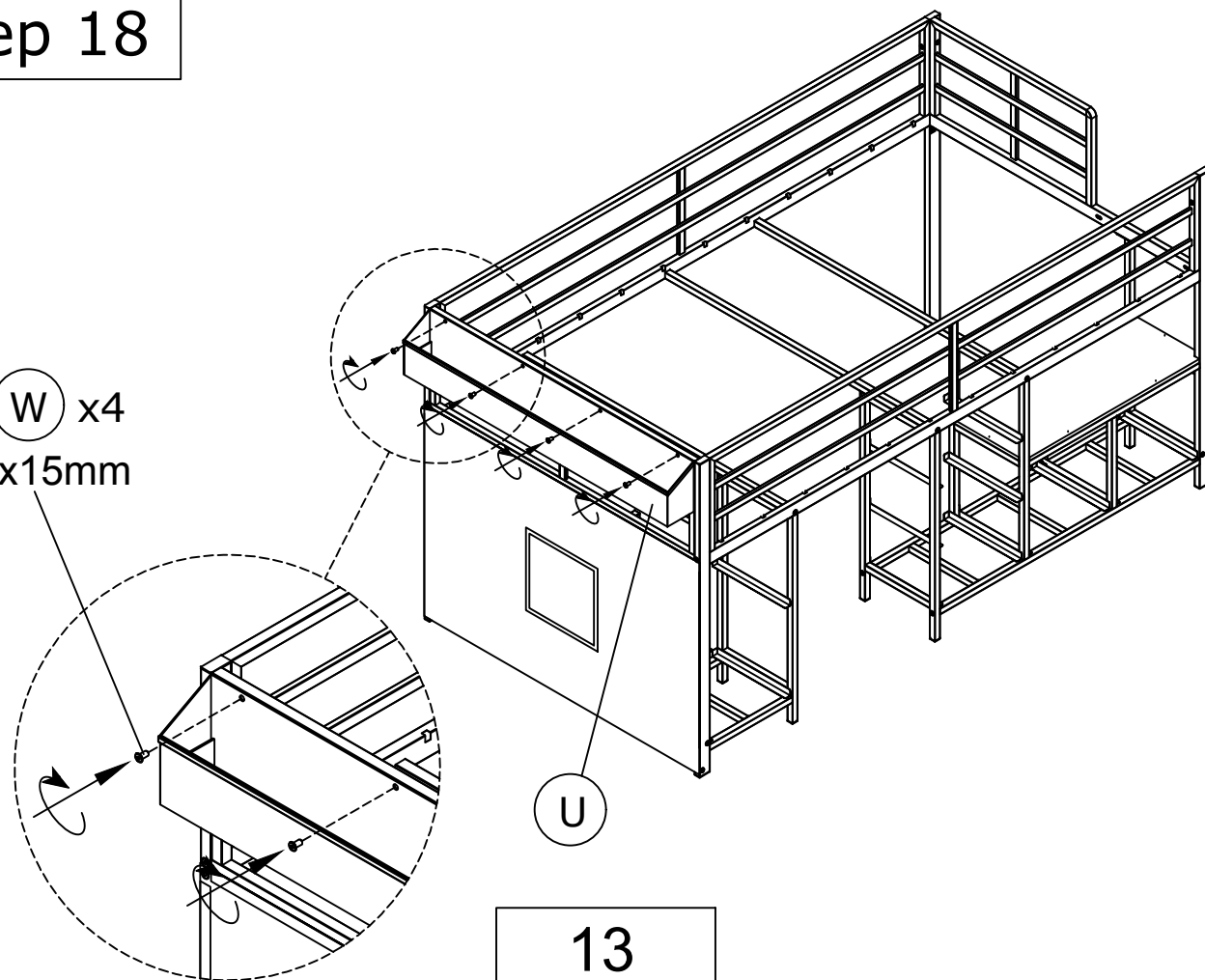

Step 19

W1 x8
M8x35mm

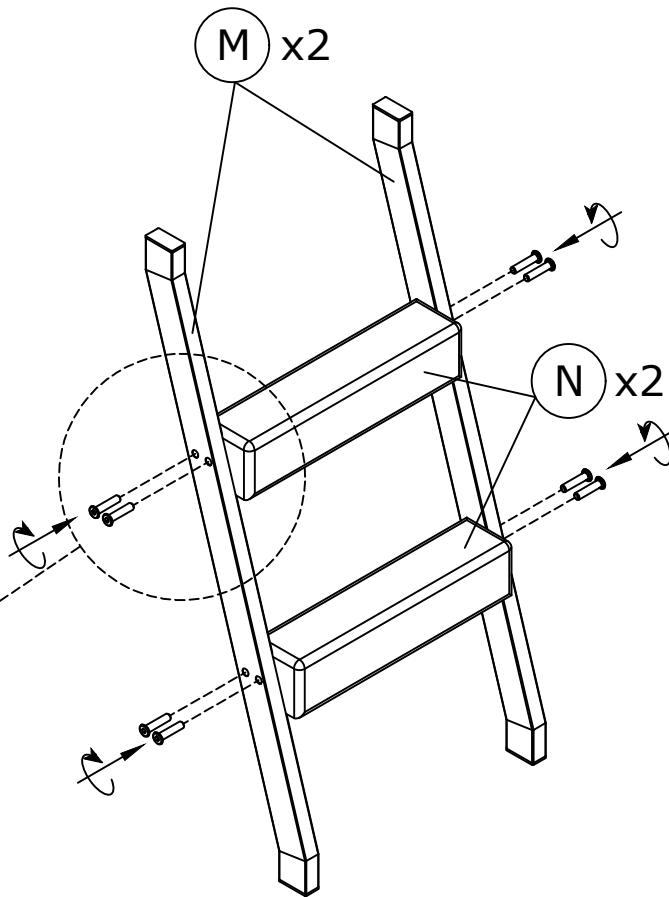
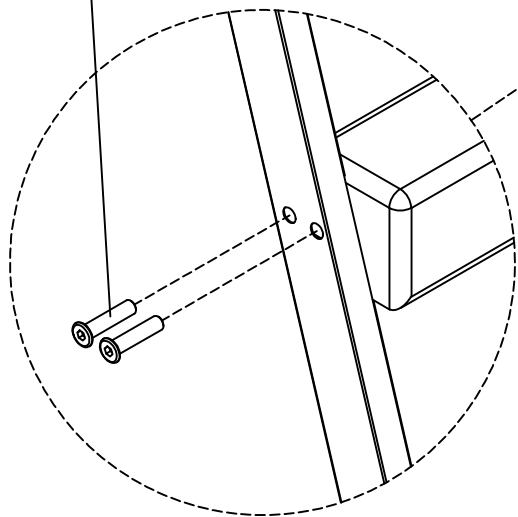

W1	8 pcs	
----	-------	---

Step 20

W1 x2
M8x35mm

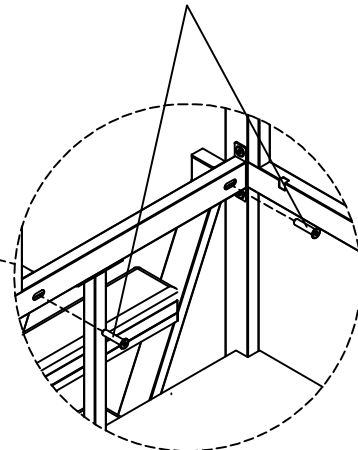
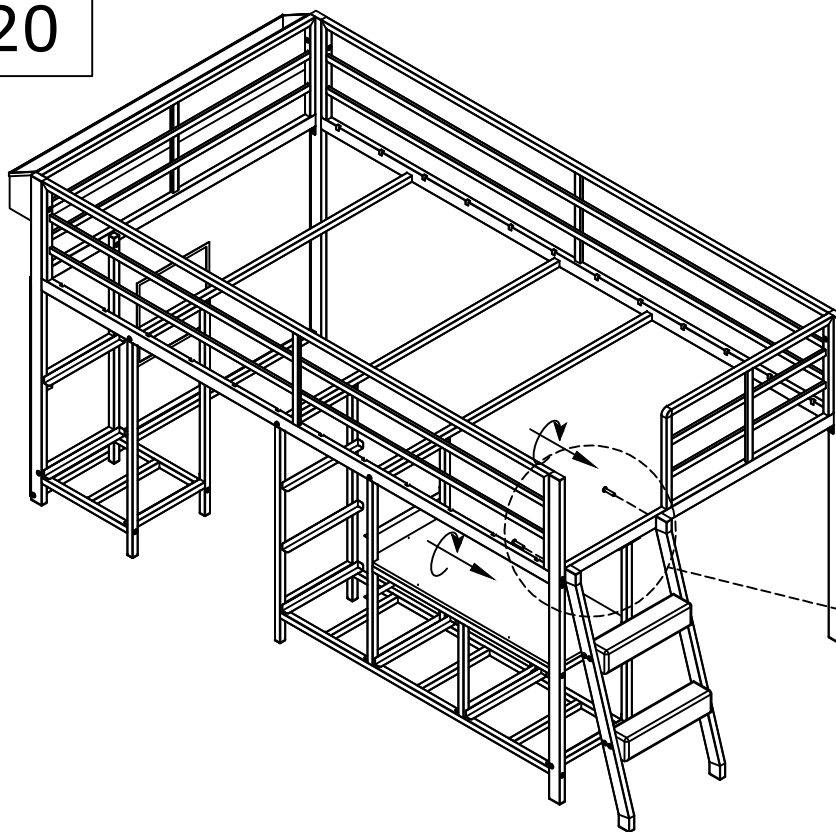

W1	2 pcs	
----	-------	---

Step 21

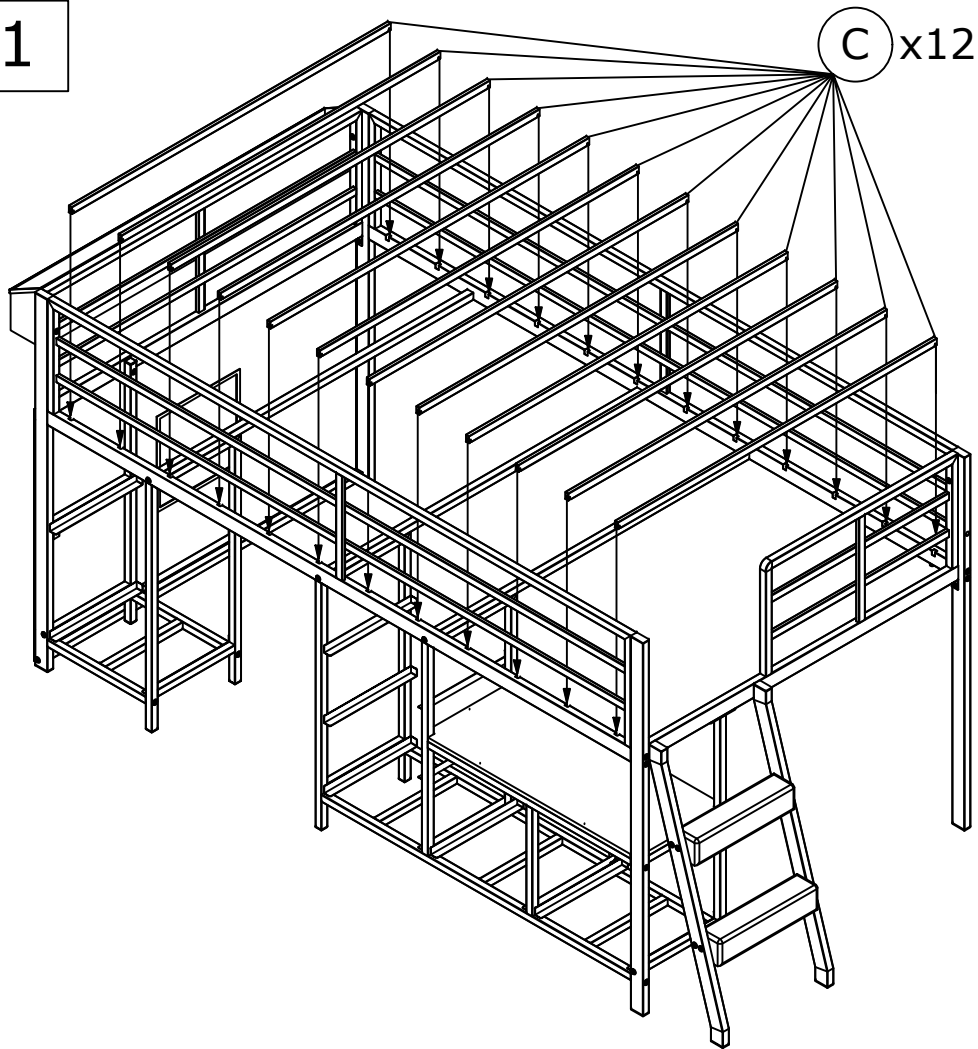

Step 22

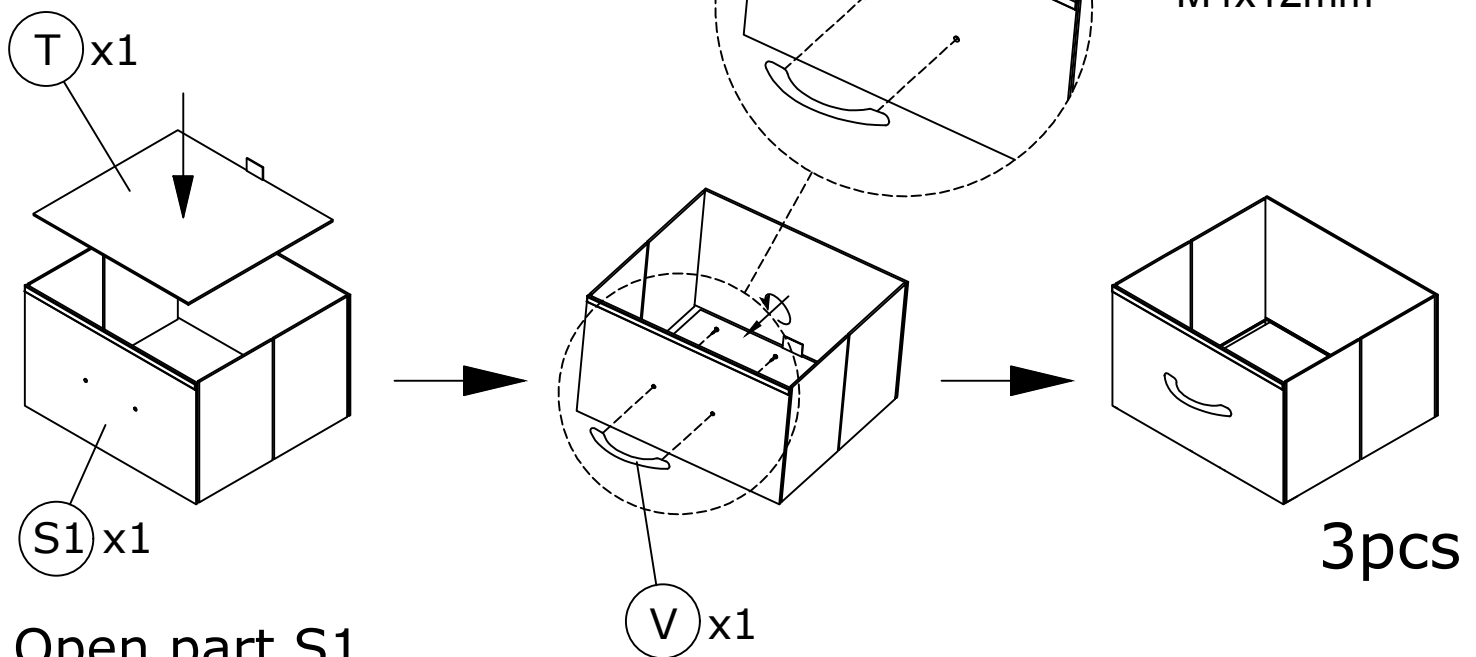

Open part S1
and put part
T in



15

V	3 pcs	
V1	6 pcs	

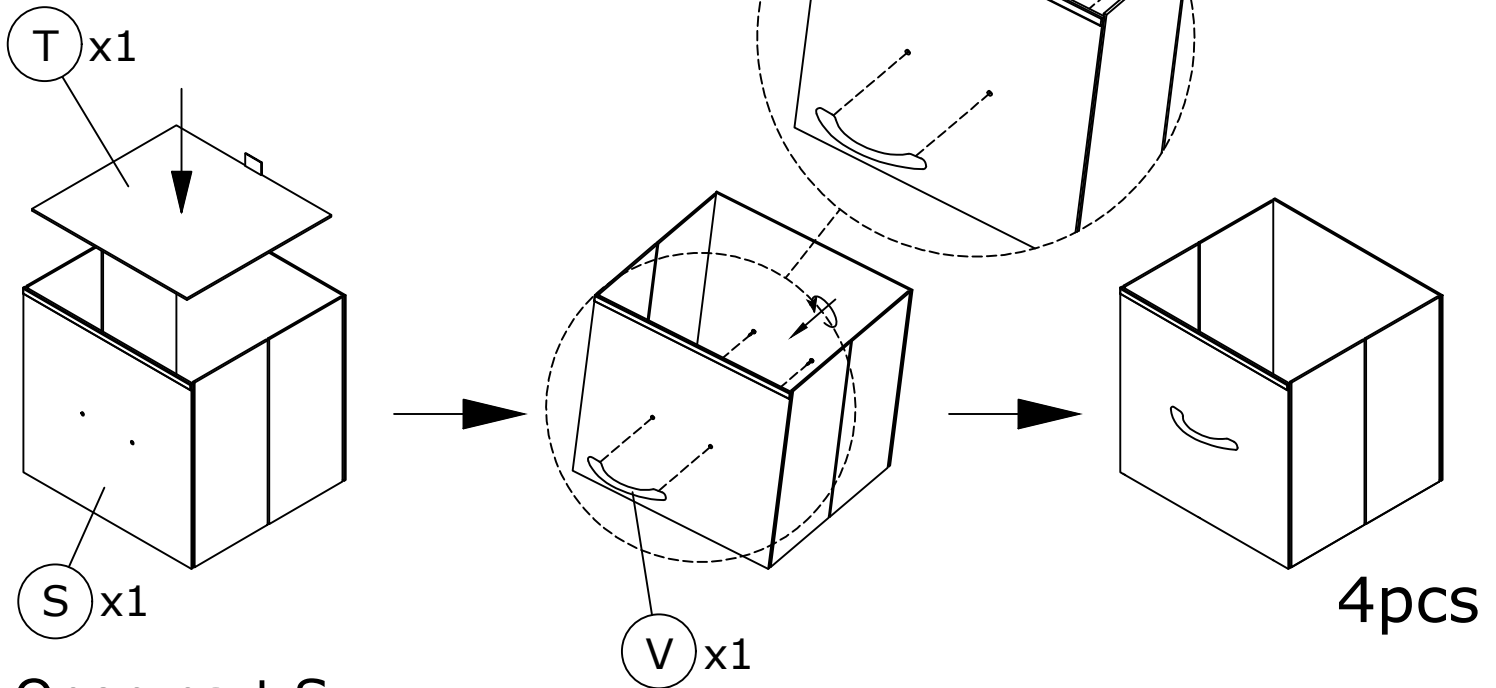
Step 23



Open part S
and put part
T in

V	4 pcs	
V1	8 pcs	

Step 24

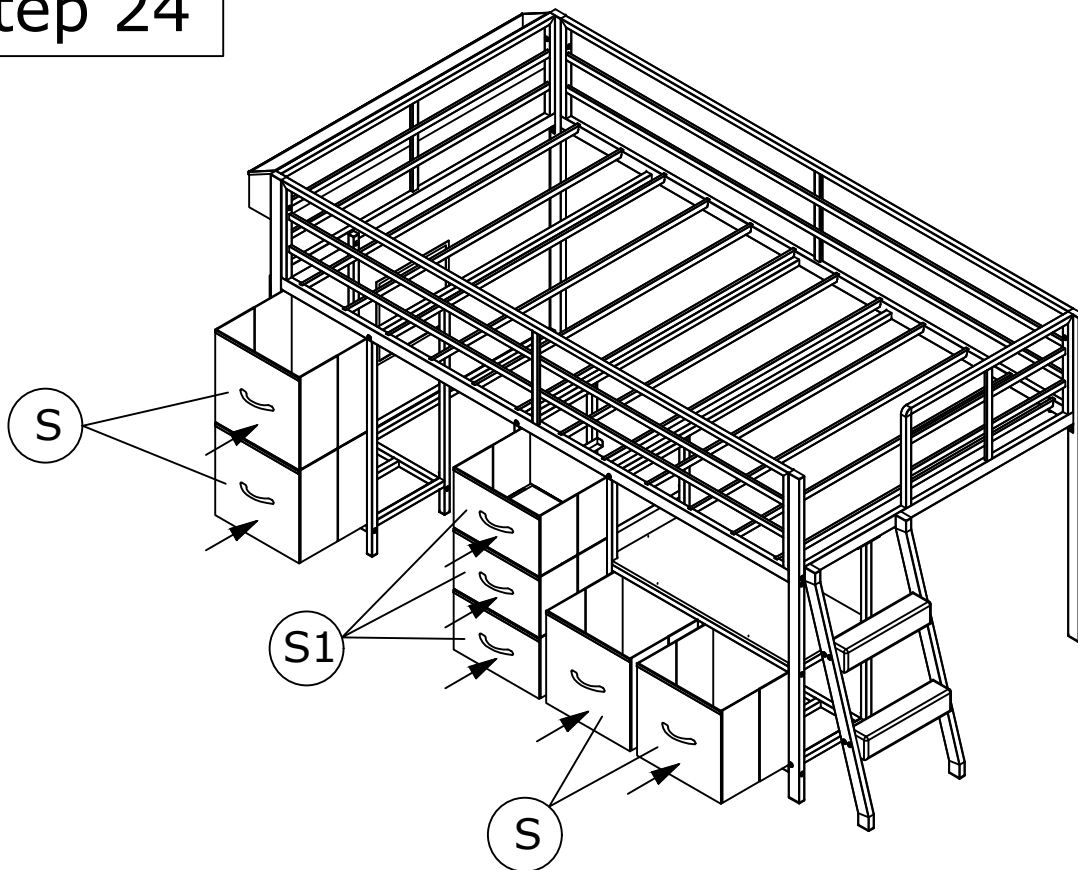

Step 25

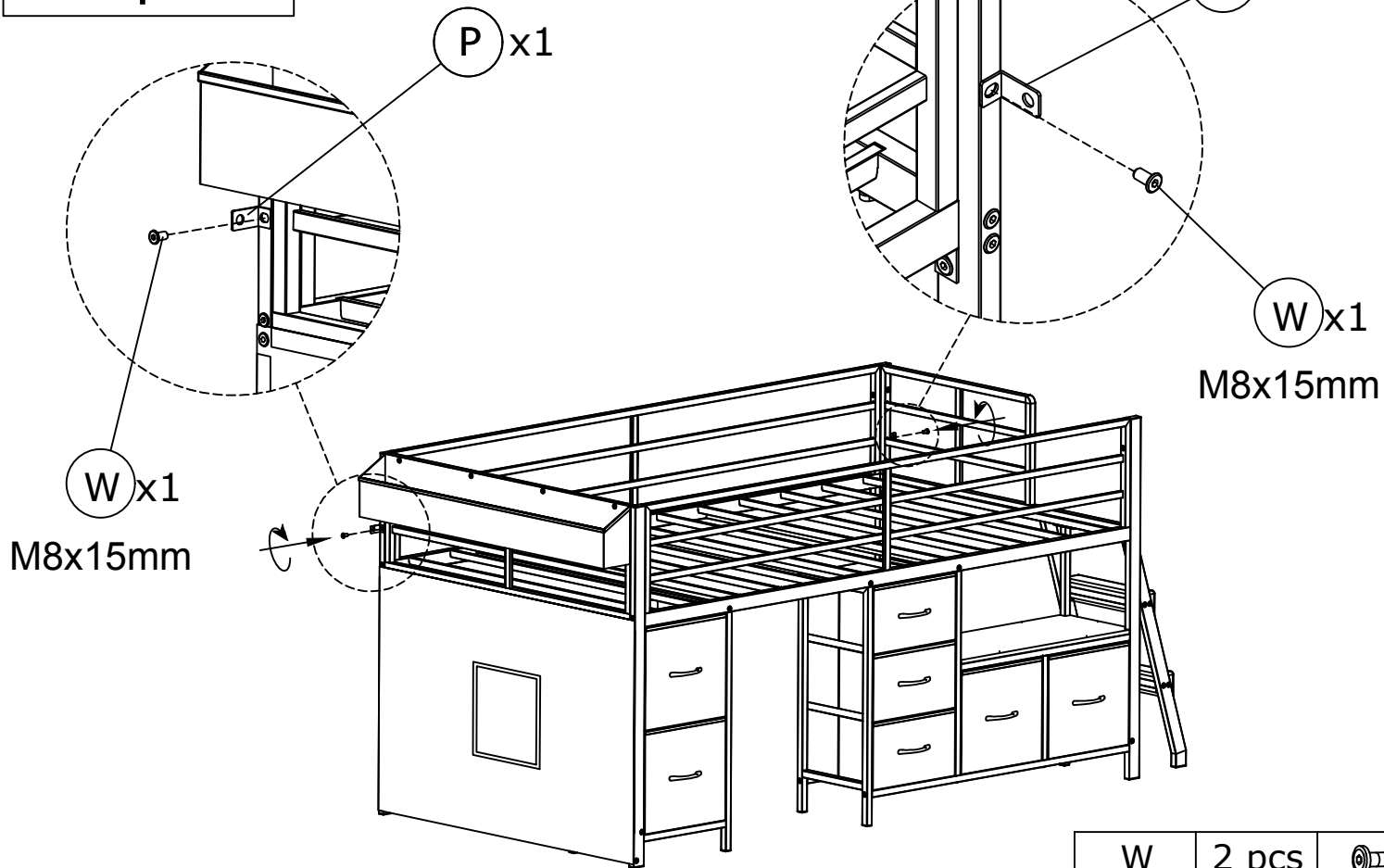



W x1
M8x15mm

P x1

P x1

W x1

M8x15mm

W	2 pcs	
P	2 pcs	

Step 26

Mark the 2 anti-roll parts P, then lift the bed to one side and drill with an 8mm drill bit 8cm deep.

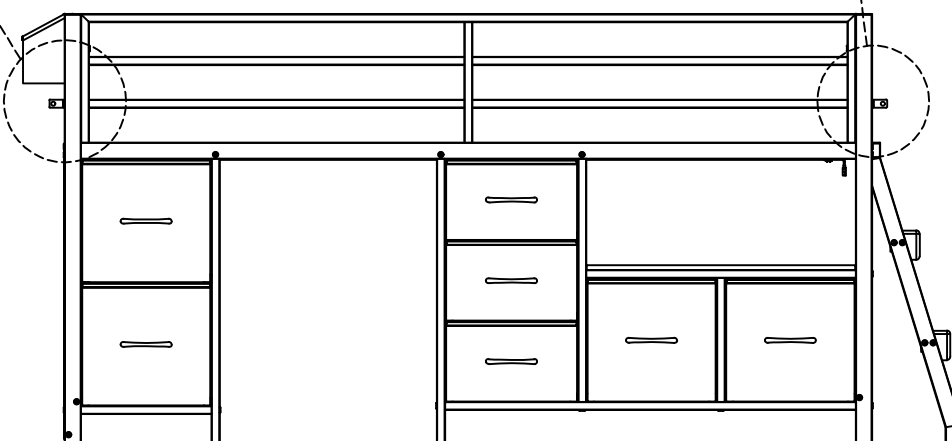
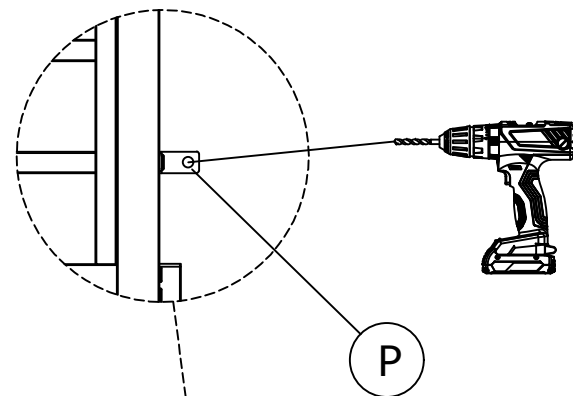
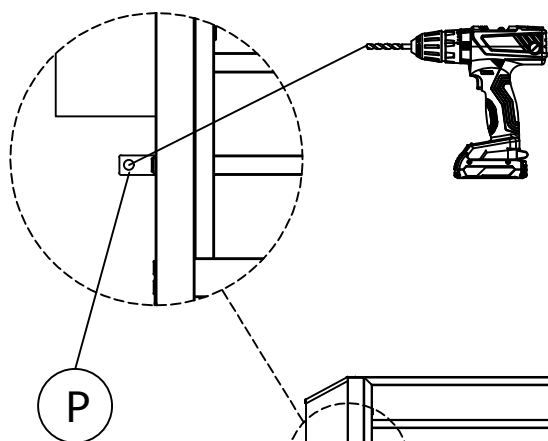

Step 27

8mm drill hole

(X) x1
M8x60mm

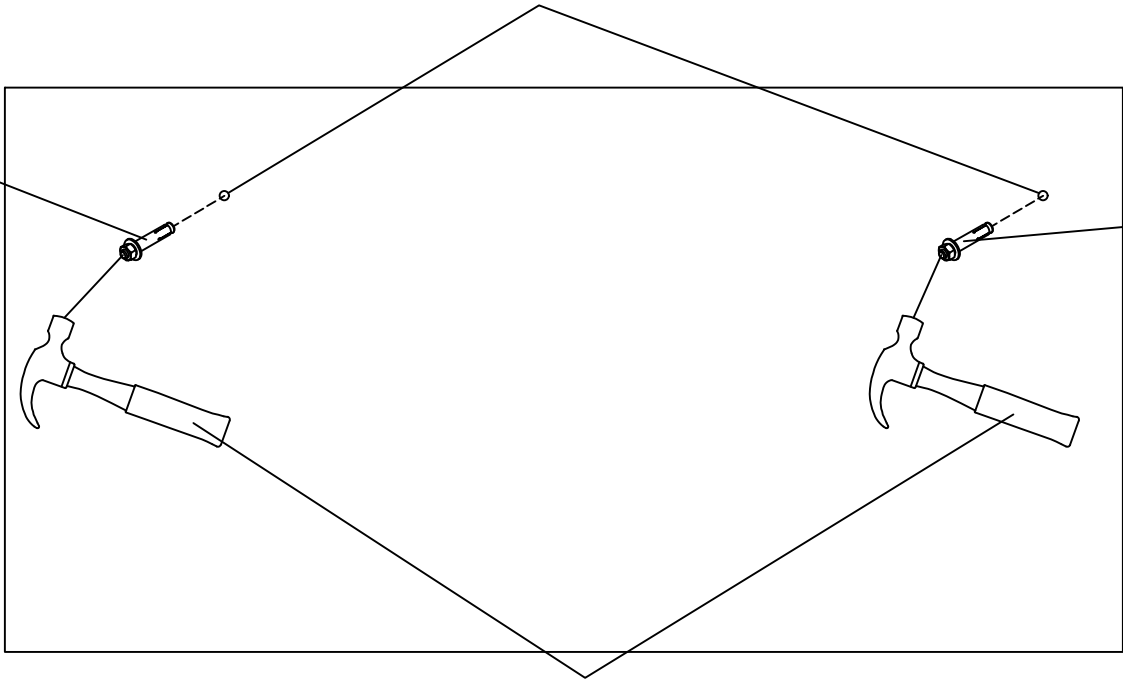

(X) x1
M8x60mm

Use a hammer to hammer the X-shaped iron plug into the 8mm drilled hole.

X

2 pcs



Step 28

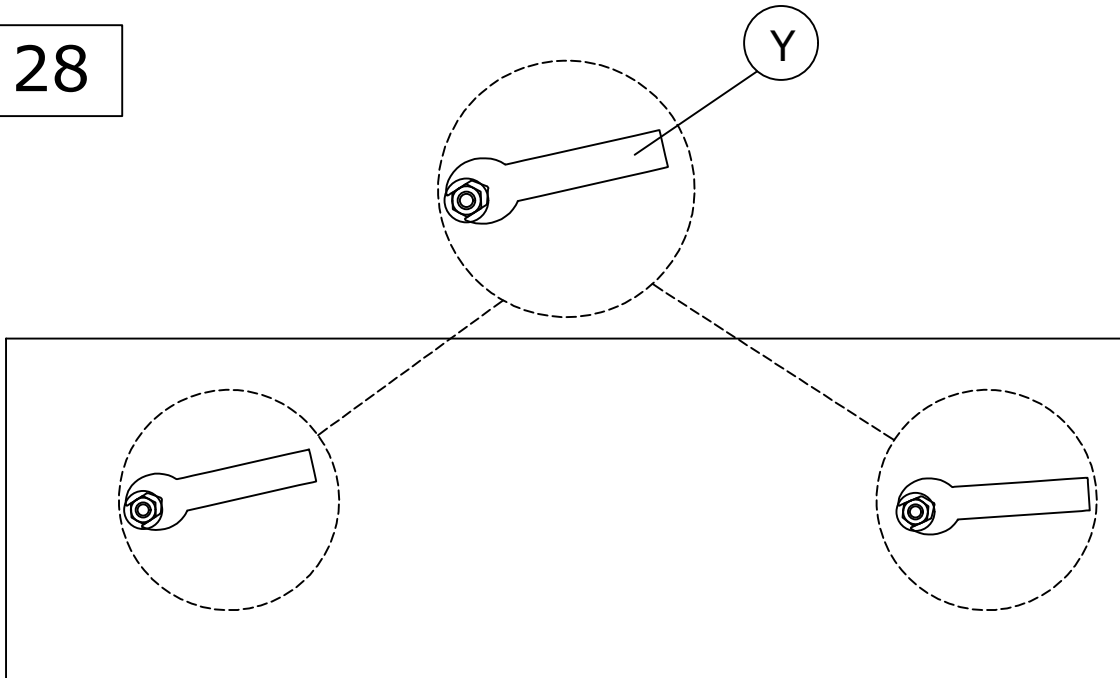

Use wrench Y to tighten the nut on the X anchor just arrived, then remove the nut and washer.

18

Y

1 pcs



Step 29

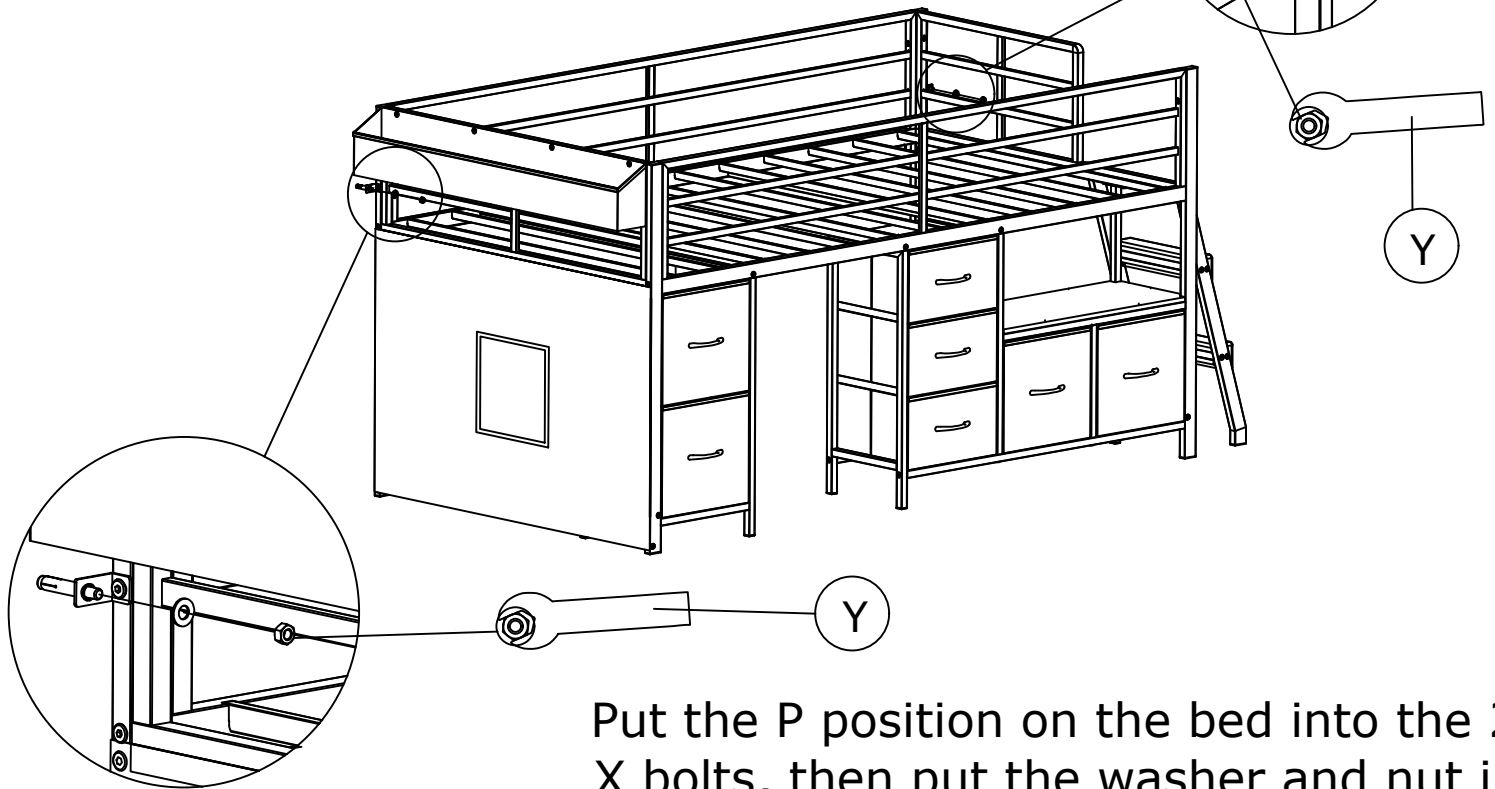

Put the P position on the bed into the 2 X bolts, then put the washer and nut in and use the Y wrench to tighten it.

Step 30

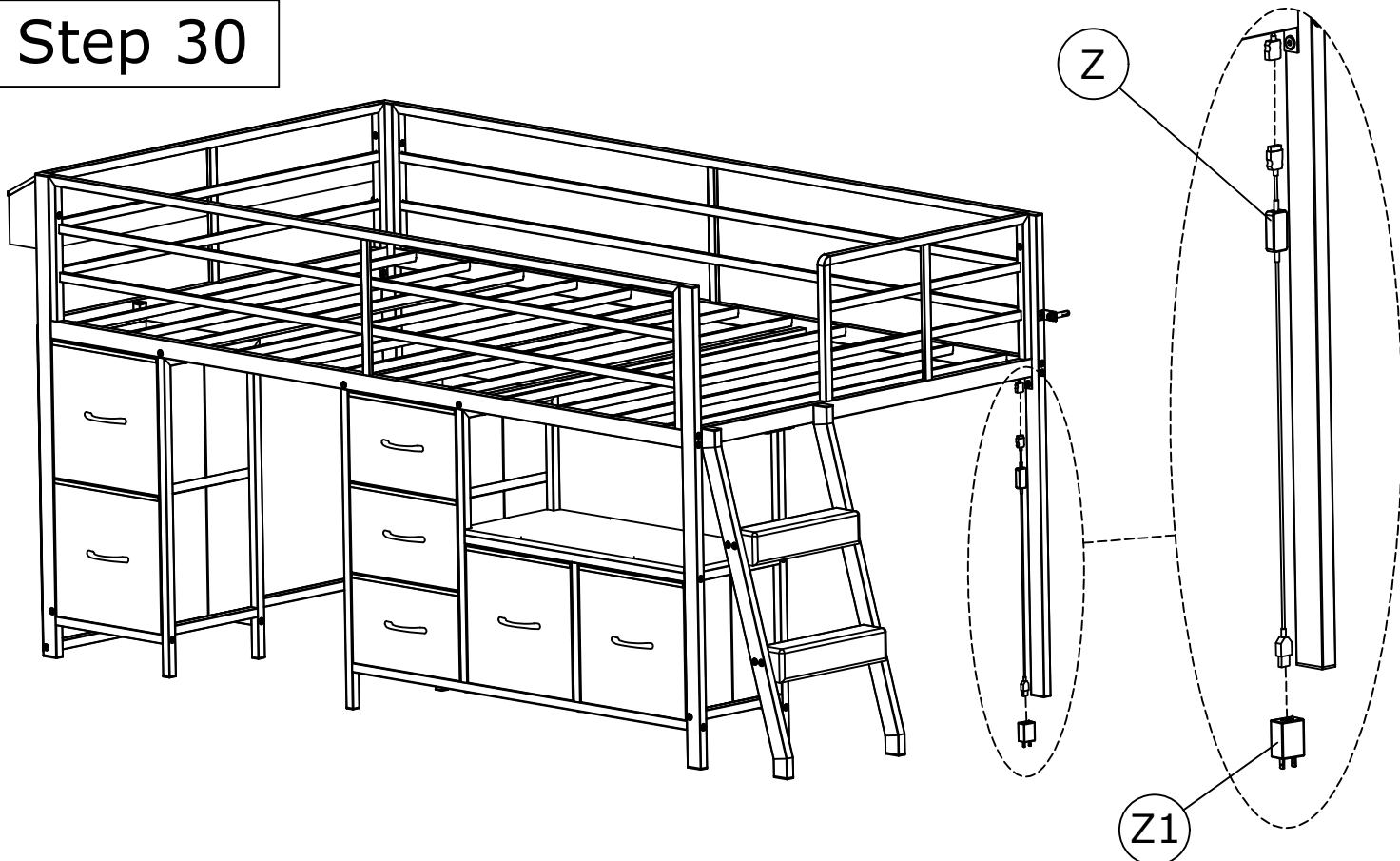

19

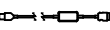
Z	1 pcs	
Z1	1 pcs	