

# Kitchen Cart



## IMPORTANT

Carefully remove all the parts from the carton and place them individually on a soft cloth to prevent scratches or other damage.

Carefully and strictly follow these assembly instructions to ensure a completed product as designed.

Do not use power tools above 8 volts to assemble.

## Part List

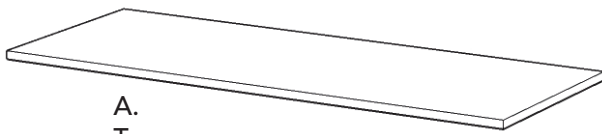

A.  
Top  
1 pc.



E.  
Rail  
1 pc.

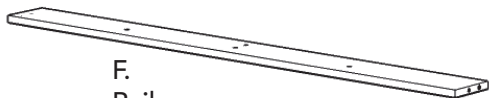

F.  
Rail  
1 pc.

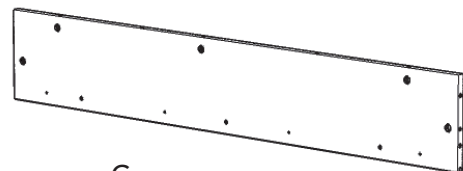

G.  
Back Rail  
1 pc.



H.  
Back Rail  
1 pc.

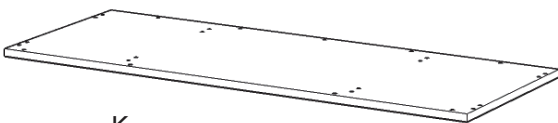

K.  
Base  
1 pc.

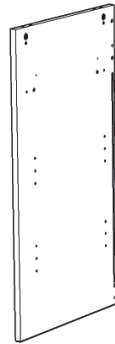

B.  
Side Panel  
1 pc.

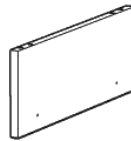

I.  
Divider  
1 pc.



L.  
Shelf  
4 pcs.

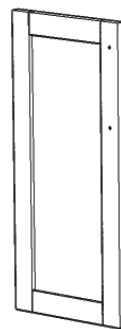

N.  
Door  
2 pcs.

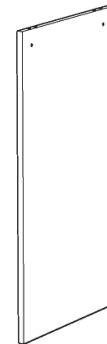

C.  
Side Panel  
1 pc.

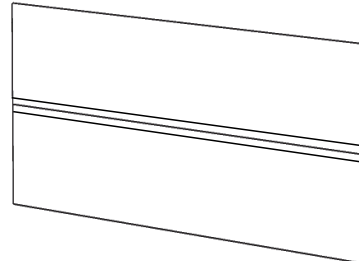

D.  
Middle Panel  
2 pcs.



M.  
Shelf  
2 pcs.

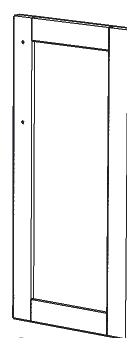

O.  
Door  
2 pcs.

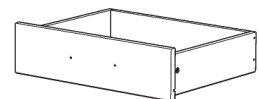

P.  
Drawer  
1 pc.

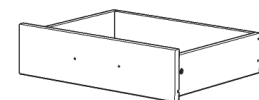

Q.  
Drawer  
1 pc.

Refer to later page(s) of these instructions for drawer assembly.

Tool(s) required for assembly: Phillips screwdriver

# Assembly Instructions 2/11

## Hardware List

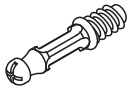

Cam Lock Screw  
29 pcs. (+4 extra)



Cam Lock  
29 pcs. (+4 extra)



M7x10  
Varianta Screw  
8 pcs. (+1 extra)



M3.5x12  
Magnet Screw  
8 pcs. (+1 extra)

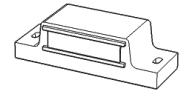

Magnet  
4 pcs.

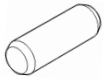

Dowel  
49 pcs. (+1 extra)



Cover  
25 pcs. (+4 extra)



M7x50  
Assembly Screw  
17 pcs. (+1 extra)



M4x16  
Caster Screw  
24 pcs. (+1 extra)

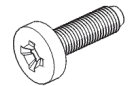

M6x25  
Head Cap Bolt  
4 pcs. (+1 extra)



M3.5x12  
Wood Screw  
24 pcs. (+1 extra)



M3.5x50  
Flat Head Screw  
8 pcs. (+1 extra)



M3.5x19  
Plastic Clip Screw  
8 pcs. (+1 extra)



Plastic Clip  
8 pcs. (+1 extra)



M4x22  
Machine Screw  
12 pcs.

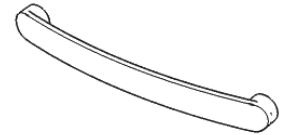

Handle  
6 pcs.



Adjustable Pin  
24 pcs. (+1 extra)



Pin  
8 pcs.

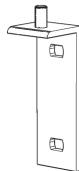

Hinge  
8 pcs.



M3x12  
Plate Screw  
4 pcs. (+1 extra)



Plate  
4 pcs.

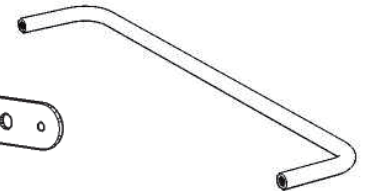

Side Bar  
2 pcs.

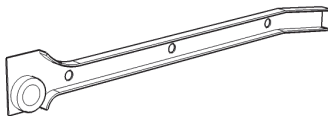

Left Guide  
2 pcs.

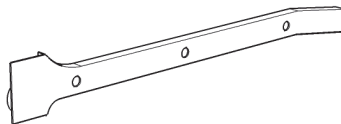

Right Guide  
2 pcs.

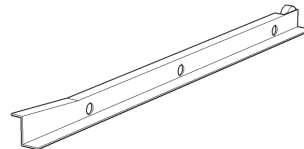

Left Runner  
2 pcs.

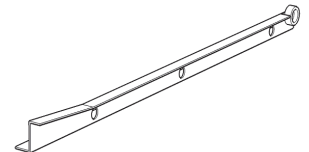

Right Runner  
2 pcs.

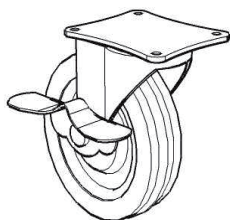

Locking  
Caster  
2 pcs.

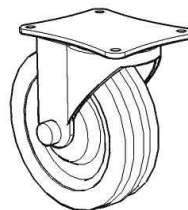

Non-Locking  
Caster  
4 pcs.

# Assembly Instructions 3/11

## IMPORTANT

- Use a soft cloth between these parts and the floor.
- Do not use power tools above 8 volts to assemble.

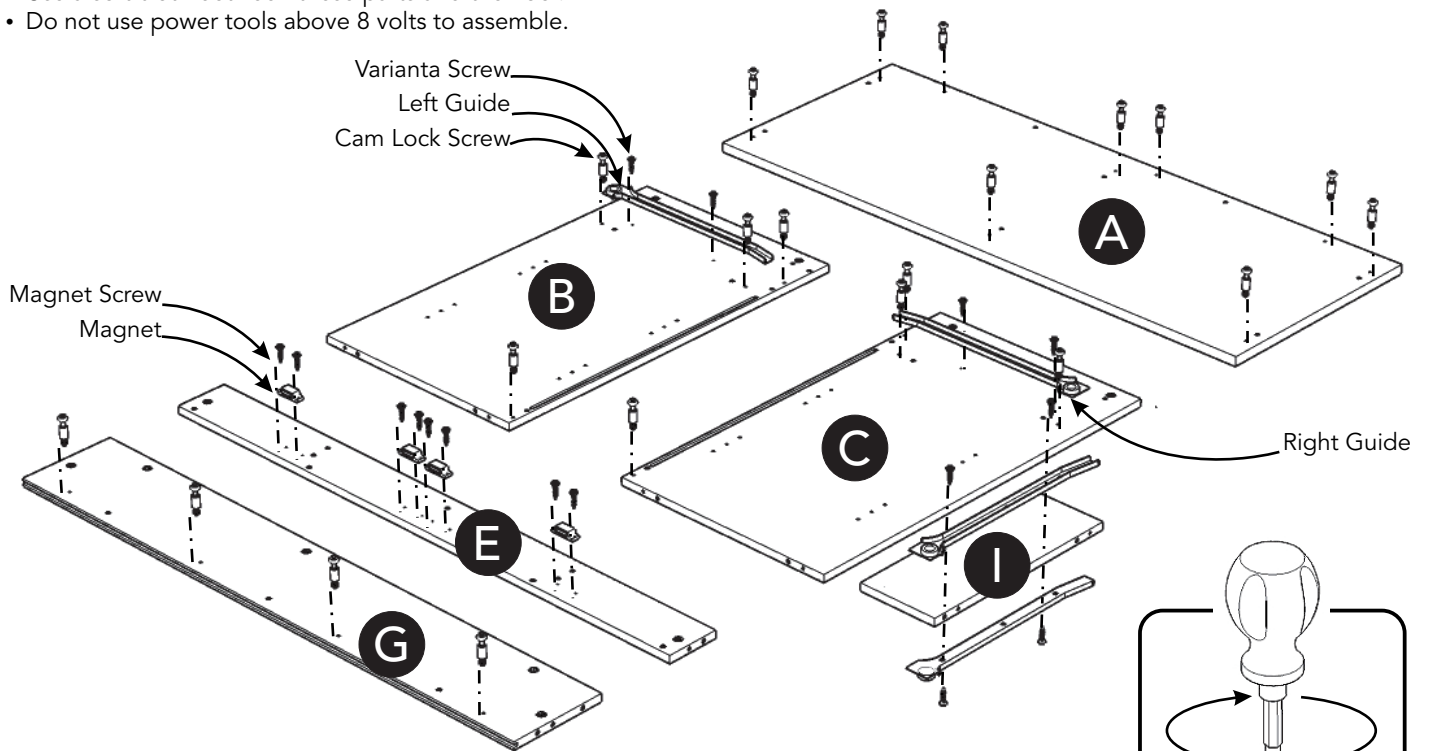

## STEP 1

Insert Cam Lock Screws into pre-drilled in Top (A), Side Panels (B), (C) and Back Rail (G), then tighten. (See Figure 1)

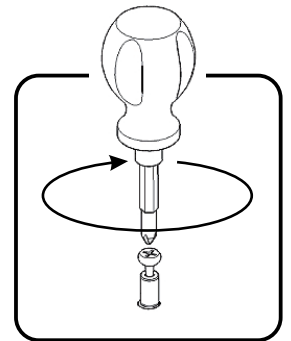

Figure 1

Attach Left Guide to Side Panel (B) and Right Guide to Side Panel (C) with Varianta Screws. (See Figure 2)

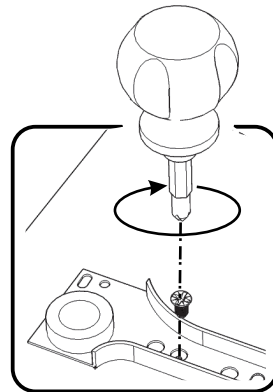

Figure 2

Attach Left Guide and Right Guide to Divider (I) with Varianta Screws.

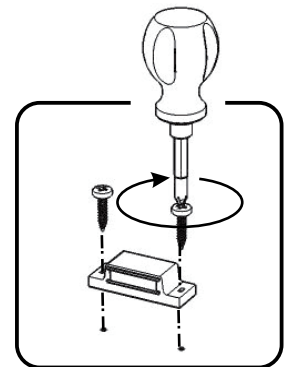

Figure 3

Attach Magnets to Rail (E) with Magnet Screws into pre-drilled holes. (See Figure 3)

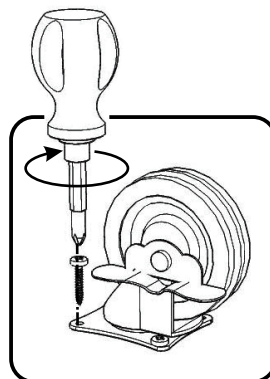
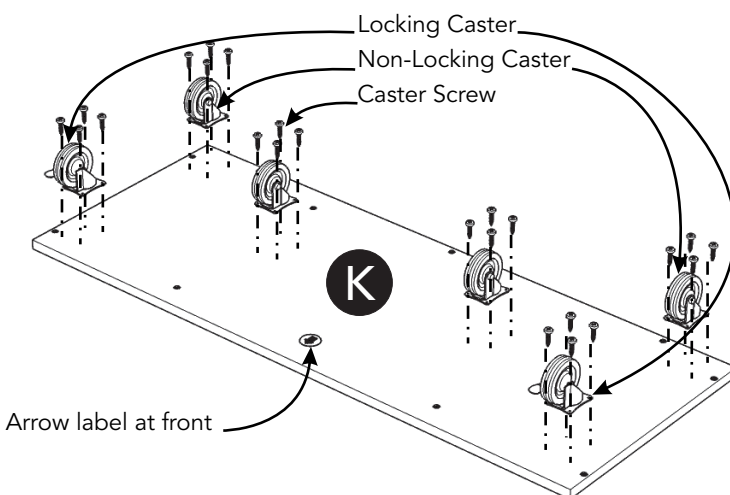

Figure 4

## STEP 2

Attach Casters to Base (K) with Caster Screws into pre-drilled holes, with Locking Casters at front. (See Figure 4)

Note: Arrow label indicates front of unit.

# Assembly Instructions 4/11

## STEP 3

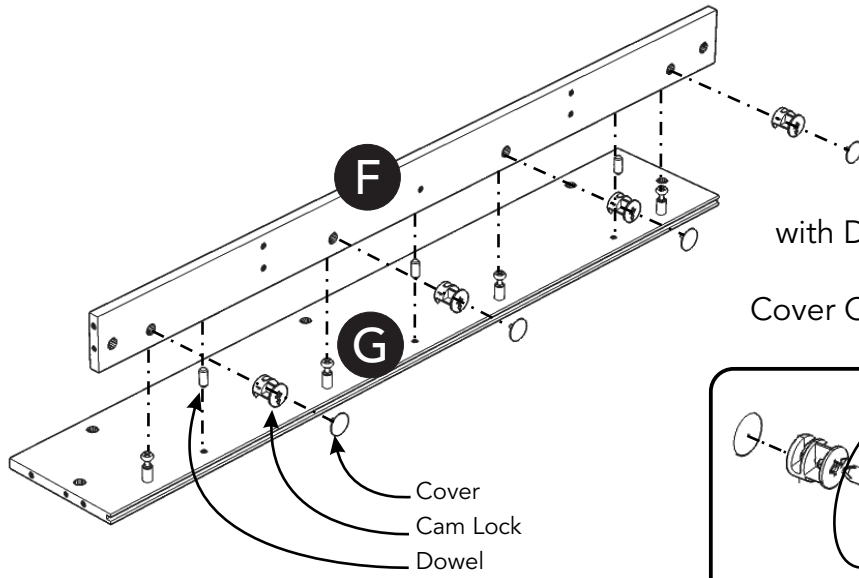

Attach Rail (F) to Back Rail (G) with Dowels and Cam Locks. (See Figure 4)

Cover Cam Locks with Covers. (See Figure 5)

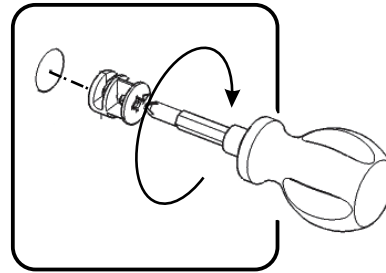

Figure 5

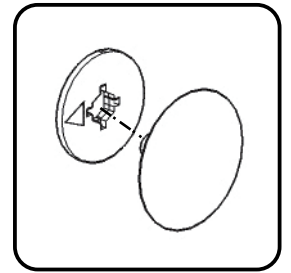
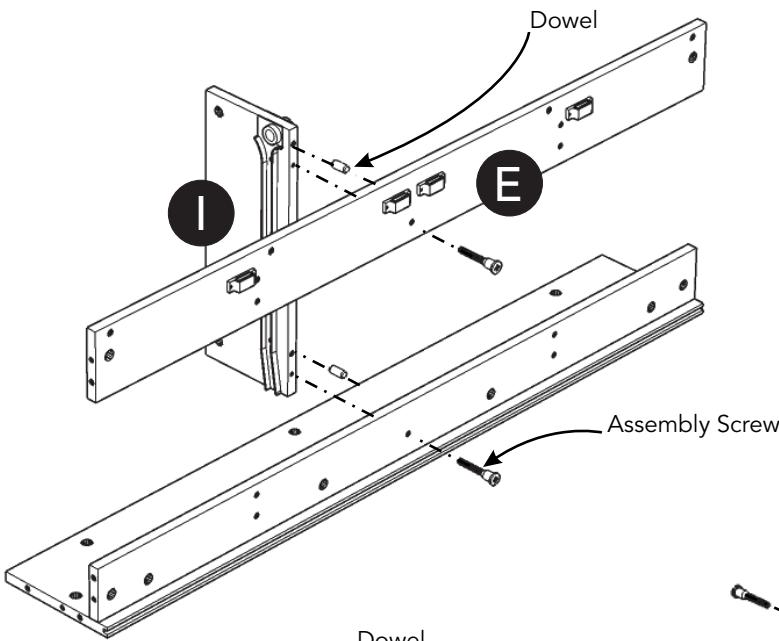
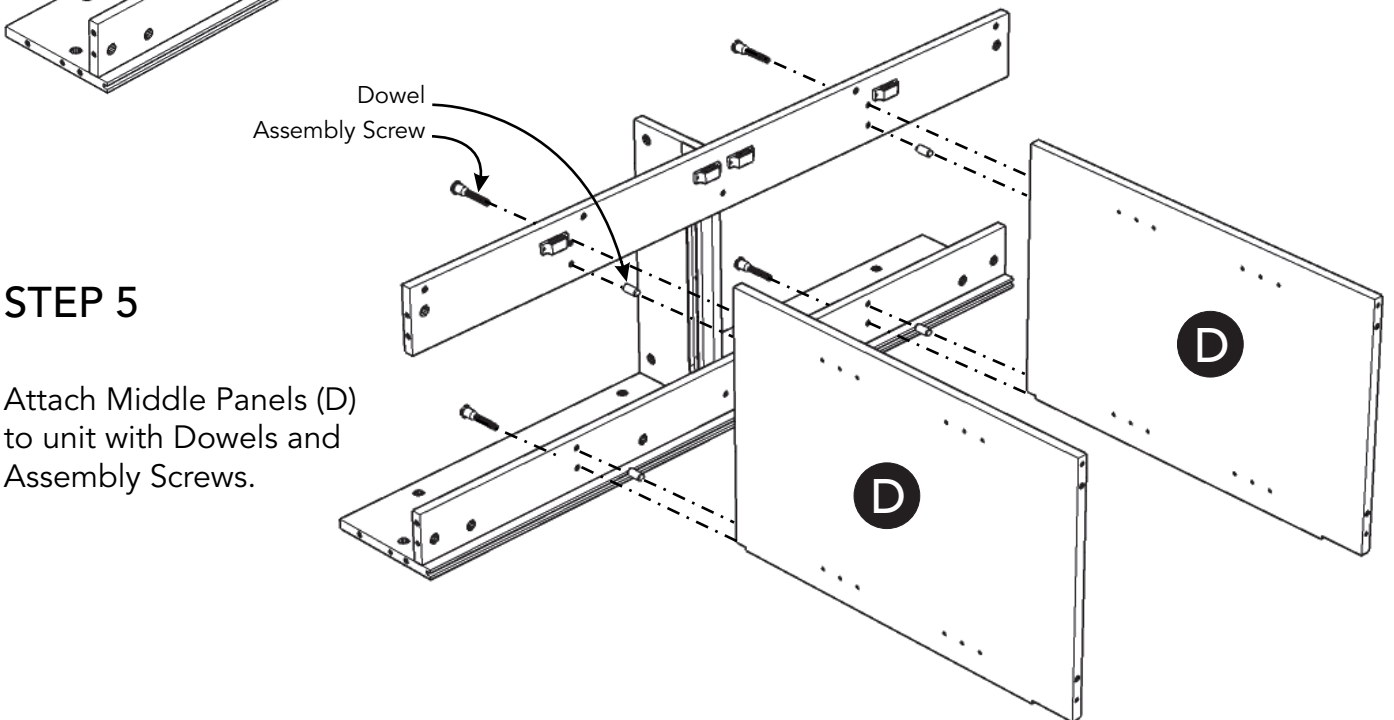

Figure 6



## STEP 4

Attach Rail (E) and unit from Step 2 to Divider (I) with Dowels and Assembly Screws.



## STEP 5

Attach Middle Panels (D) to unit with Dowels and Assembly Screws.

## Assembly Instructions 5/11

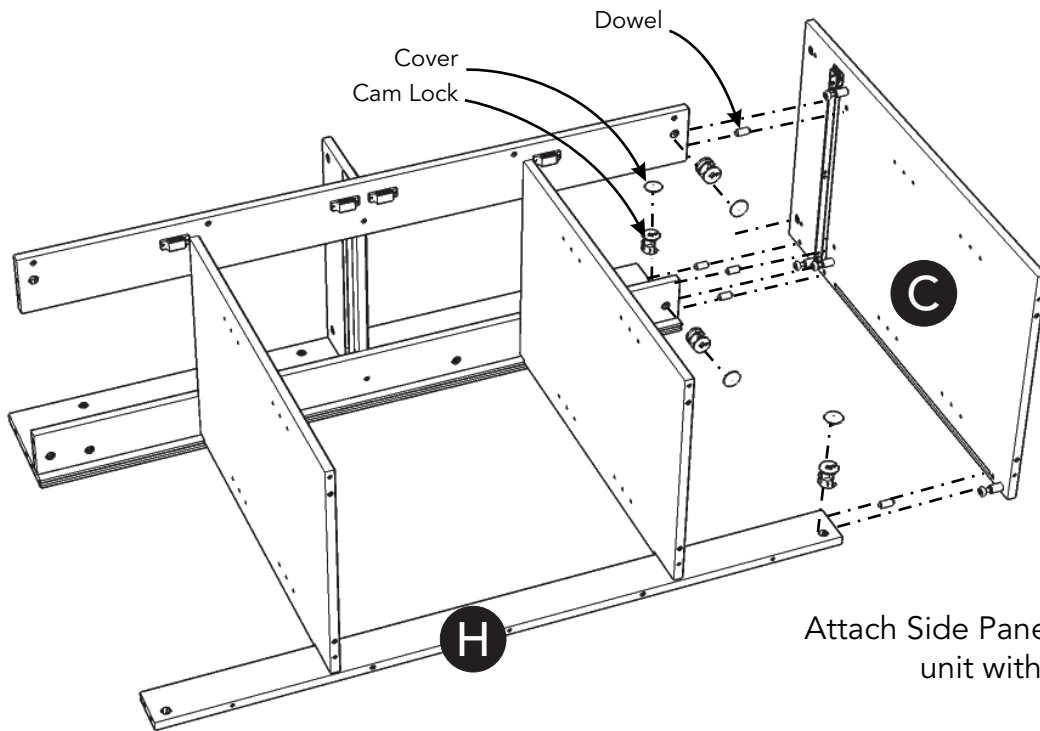

### STEP 6

Attach Side Panel (C) and Back Rail (H) to unit with Dowels and Cam Locks.

Cover Cam Locks with Covers.

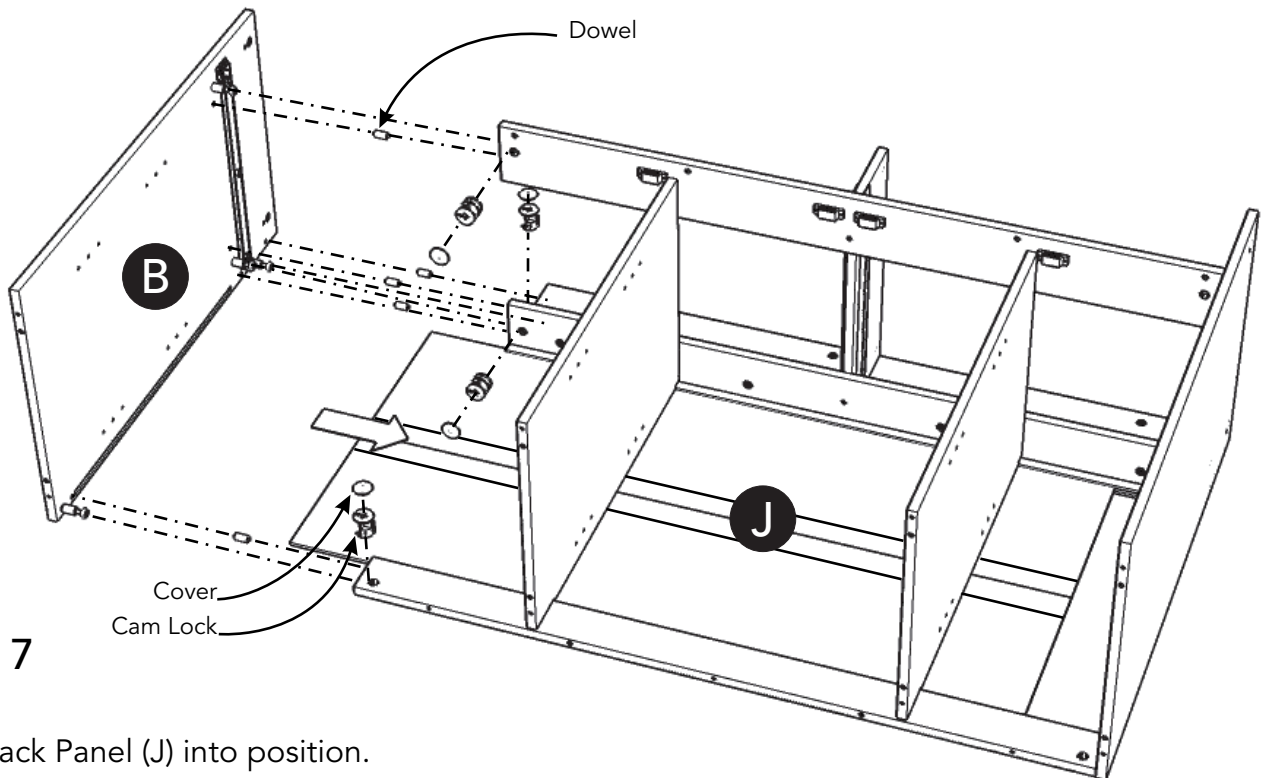

### STEP 7

Slide Back Panel (J) into position.

Attach Side Panel (B) to unit with Dowels and Cam Locks.

Cover Cam Locks with Covers.

### STEP 8

Attach Base (K) to unit with Dowels and Assembly Screws.

Dowel  
Assembly Screw

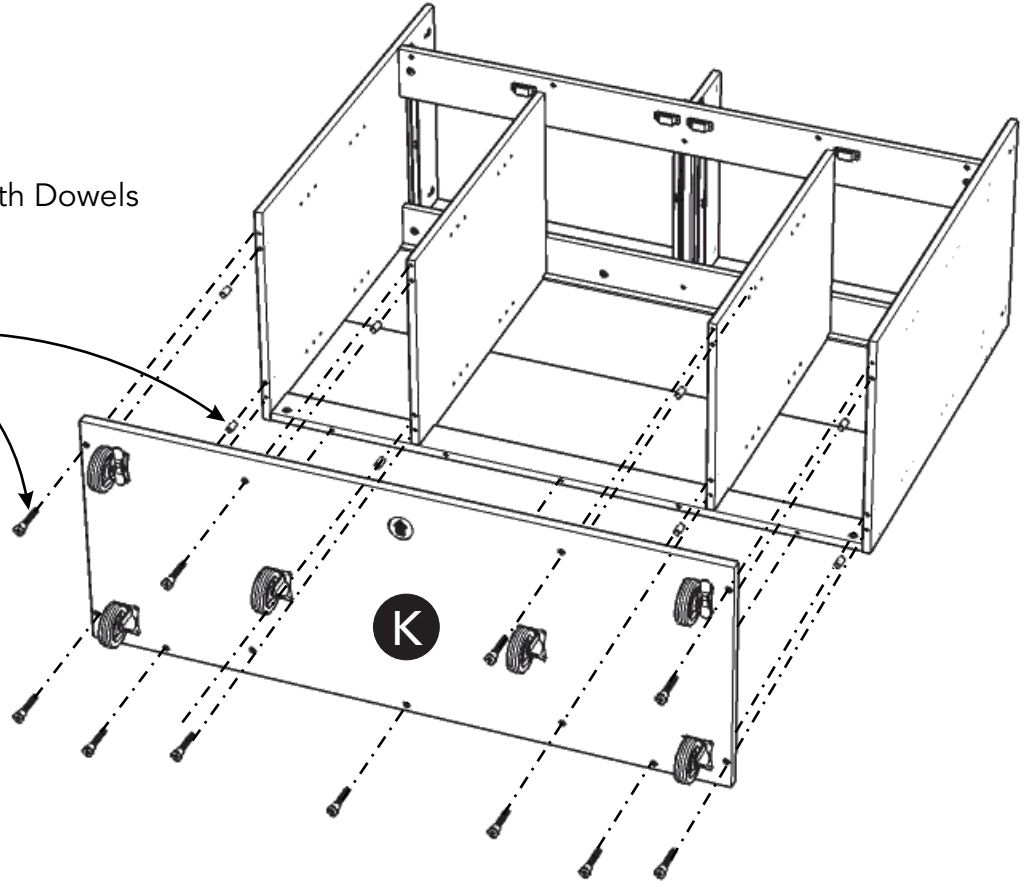

### STEP 9

Turn unit to its upright position.

Attach Top (A) to unit with Dowels and Cam Locks.

Cover Cam Locks with Covers.

Attach Plastic Clips to unit with Plastic Clip Screws. (See Figure 7)

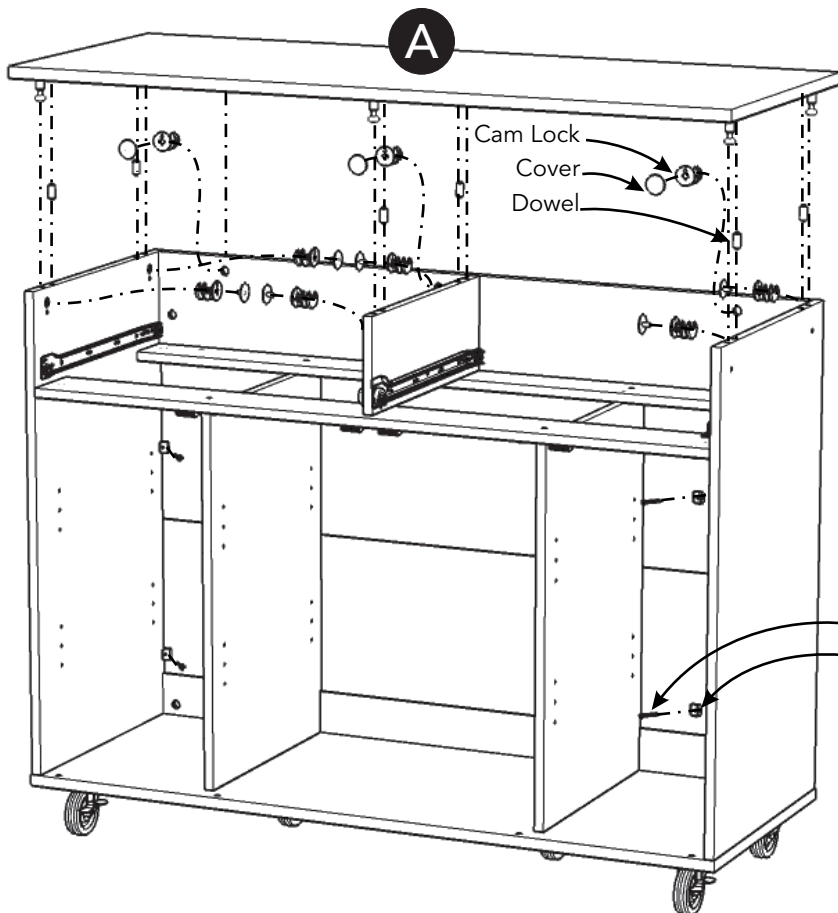

Plastic Clip Screw  
Plastic Clip

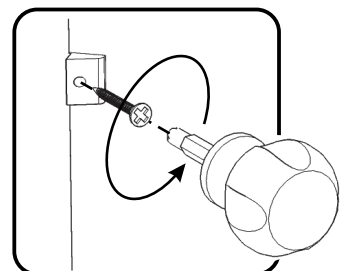
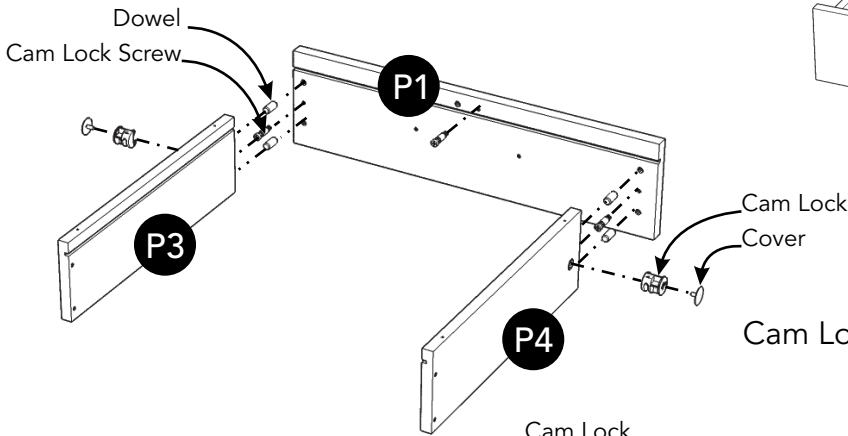

Figure 7

# Assembly Instructions 7/11

## Drawer (P)



### STEP 10

Attach Drawer Sides (P3) and (P4) to Drawer Front (P1) with Cam Lock Screws, Dowels and Cam Locks.

Cover Cam Locks with Covers.

### STEP 11

Slide Drawer Bottom (P5) into groove.

Attach Support (P6) and Drawer Back (P2) to unit with Cam Lock Screws, Dowels, Cam Locks and Flat Head Screws.

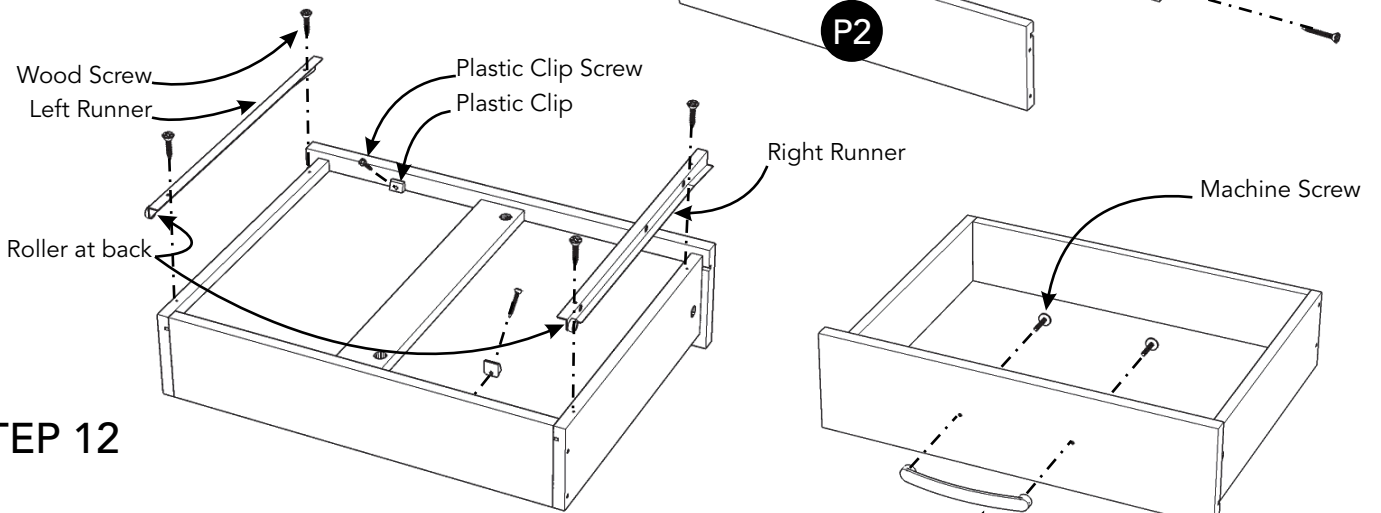
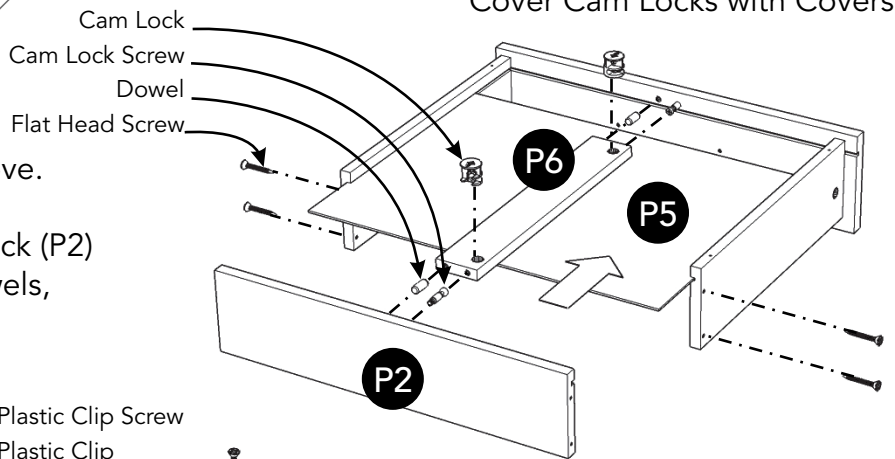

### STEP 12

Attach Left Runner and Right Runner to unit with Wood Screws.

Attach Plastic Clips to unit with Plastic Clip Screws.

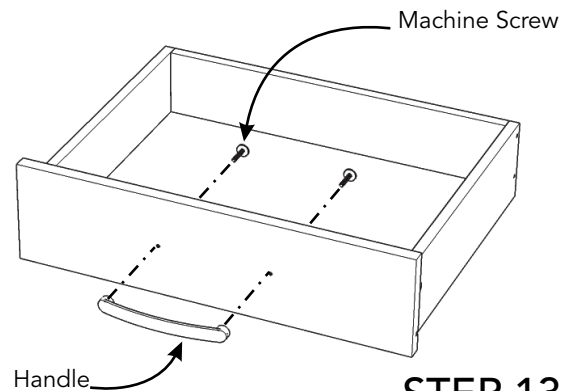

### STEP 13

Attach Handle with Machine Screws.

## Part List

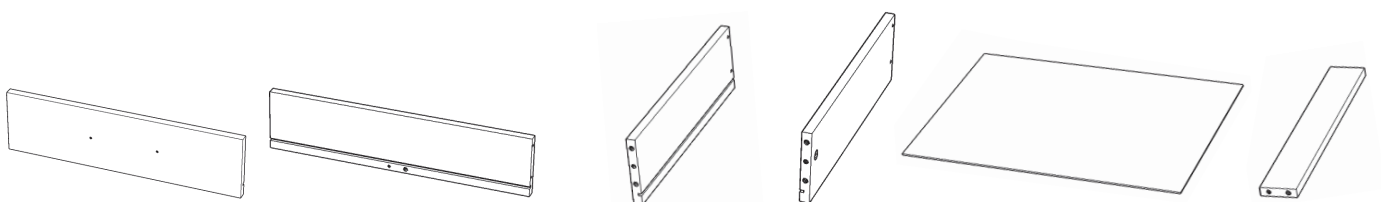

P1.  
Drawer Front  
1 pc.

P2.  
Drawer Back  
1 pc.

P3.  
Drawer Side  
1 pc.

P4.  
Drawer Side  
1 pc.

P5.  
Drawer Bottom  
1 pc.

P6.  
Support  
1 pc.

# Assembly Instructions 8/11

## Drawer (Q)

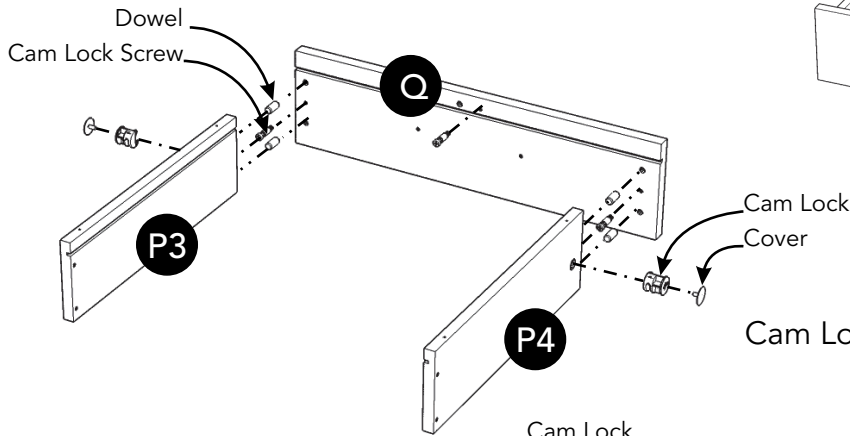

### STEP 14

Attach Drawer Sides (P3) and (P4) to Drawer Front (Q) with Cam Lock Screws, Dowels and Cam Locks.

Cover Cam Locks with Covers.

### STEP 15

Slide Drawer Bottom (P5) into groove.

Attach Support (P6) and Drawer Back (P2) to unit with Cam Lock Screws, Dowels, Cam Locks and Flat Head Screws.

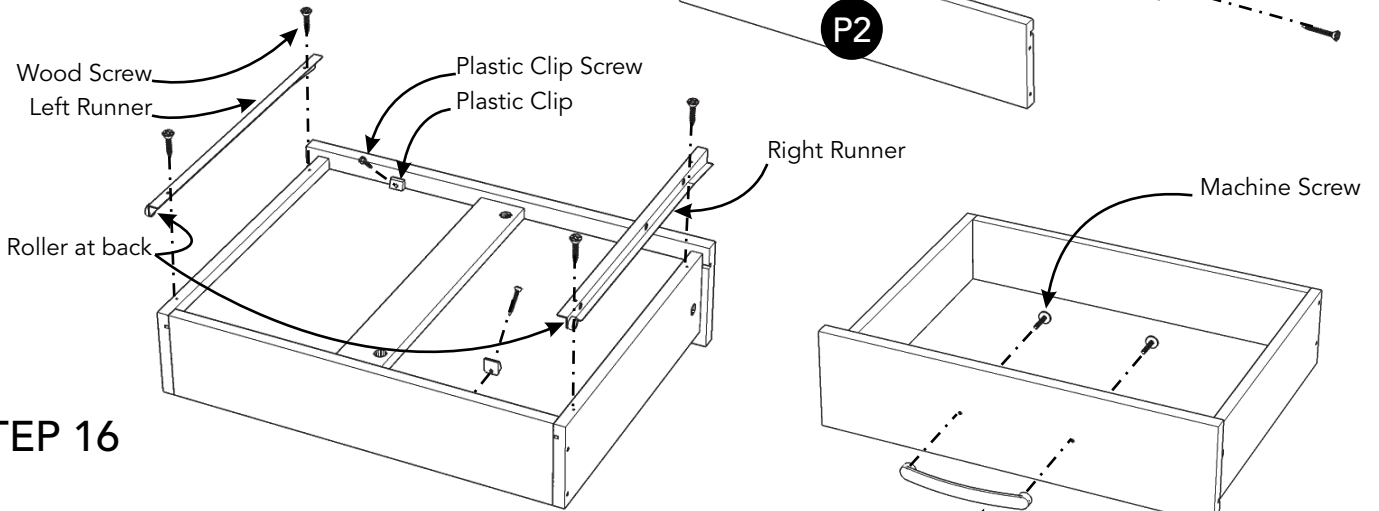
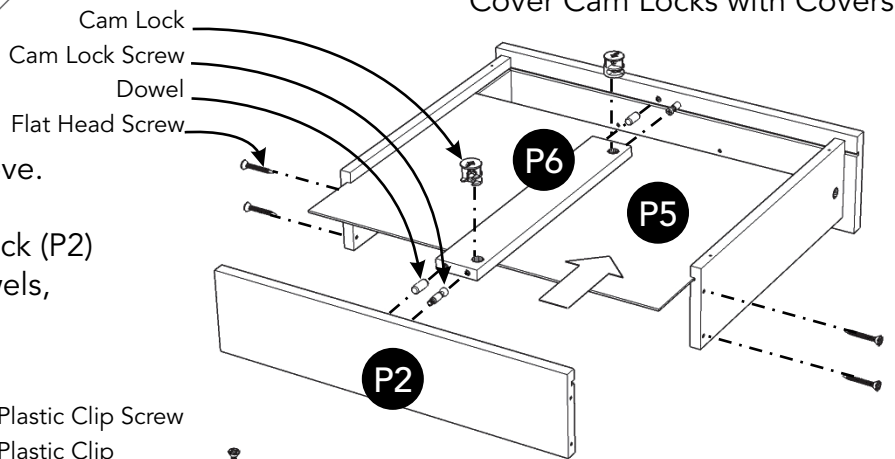

### STEP 16

Attach Left Runner and Right Runner to unit with Wood Screws.

Attach Plastic Clips to unit with Plastic Clip Screws.

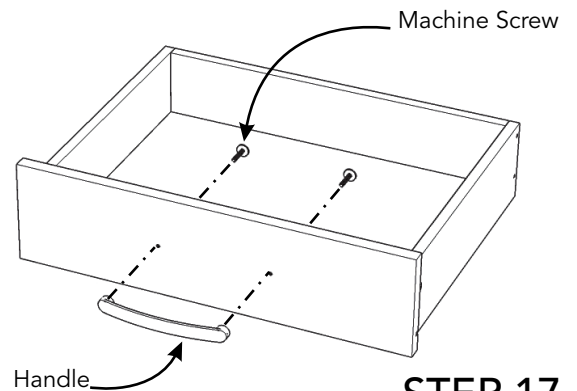

### STEP 17

Attach Handle with Machine Screws.

## Part List

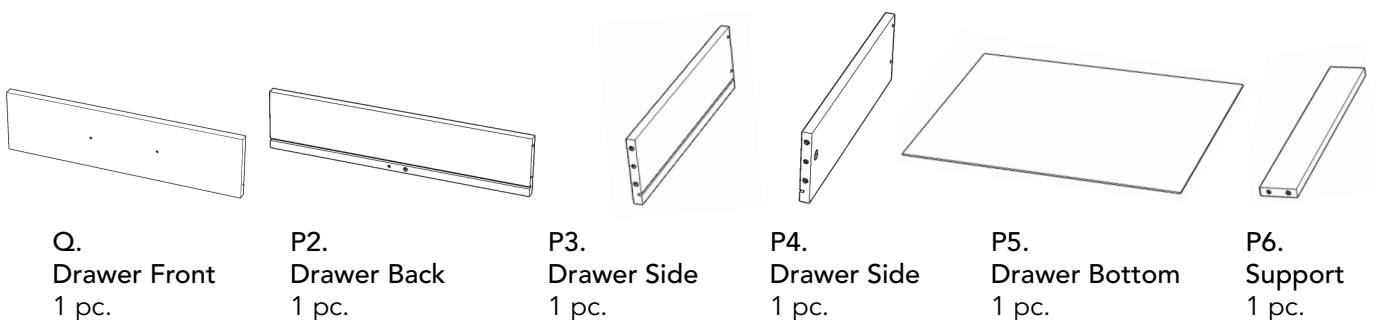

# Assembly Instructions 9/11

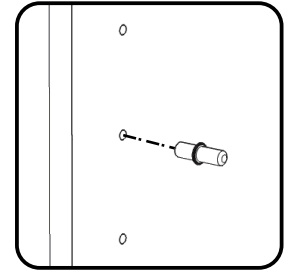
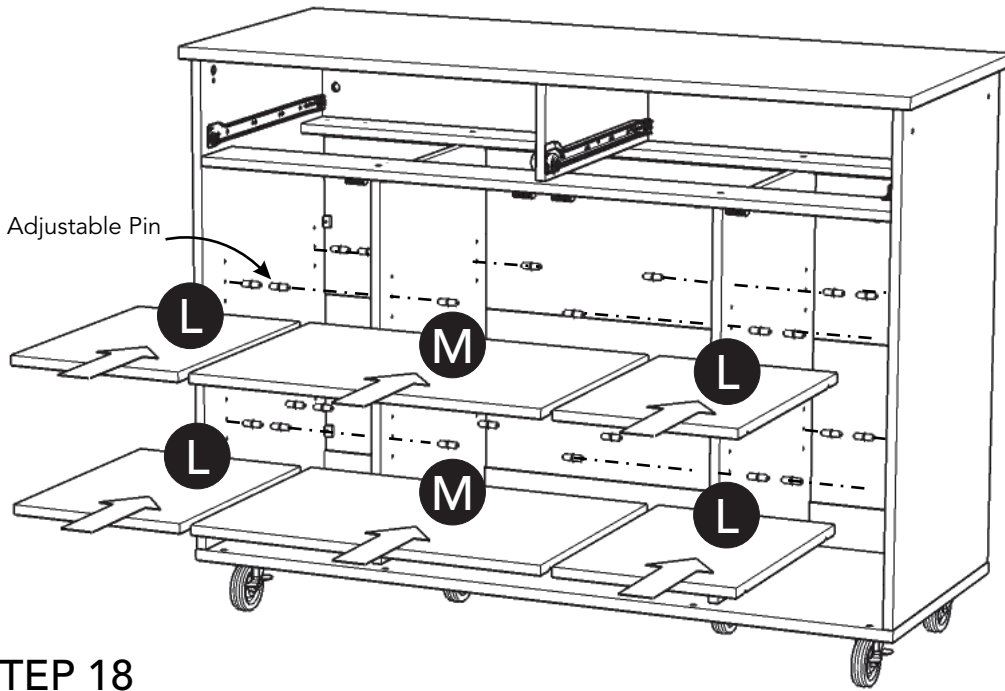

Figure 8

## STEP 18

Insert Adjustable Pins into side panels and middle panels at desired level. (See Figure 8)

Place Shelves (L) and (M) into position.

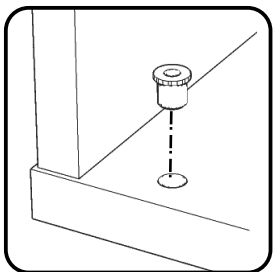

Figure 9

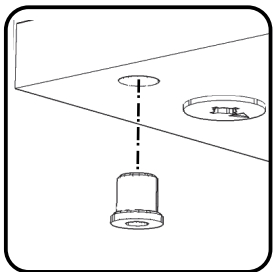
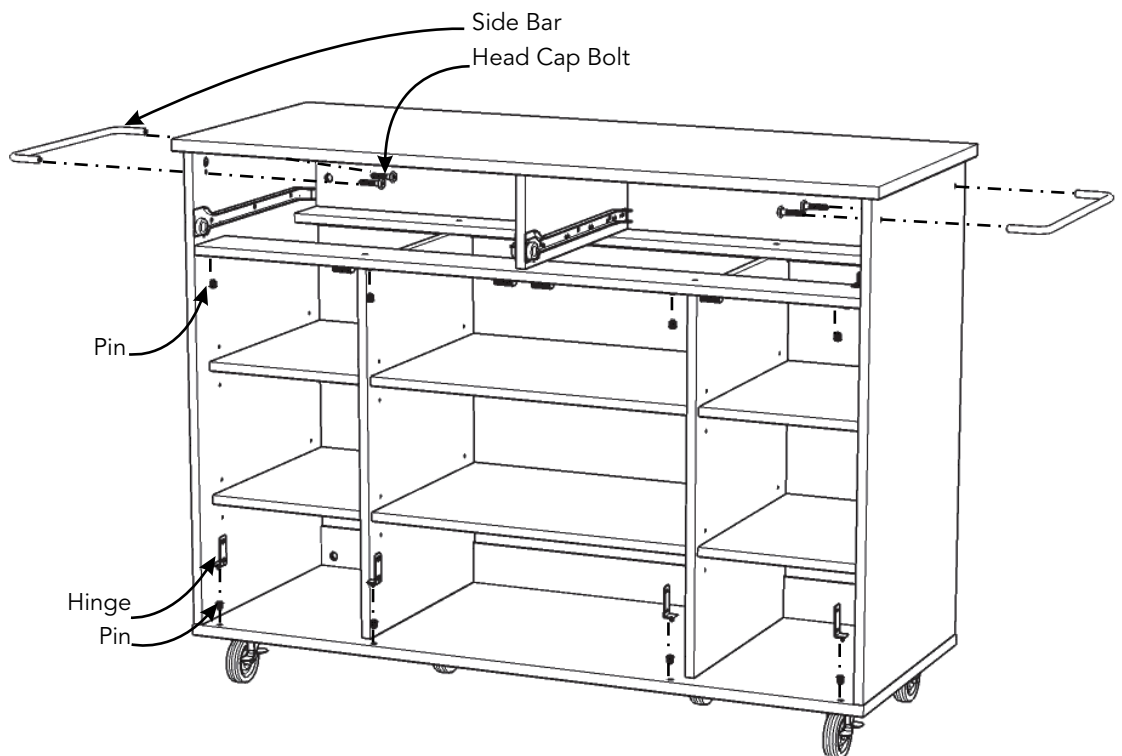

Figure 10



## STEP 19

Attach Side Bars to unit with Head Cap Bolts into pre-drilled holes.

Insert Pins into pre-drilled holes in unit. (See Figures 9 and 10)

Insert Hinges into Pins. (See Figure 11)

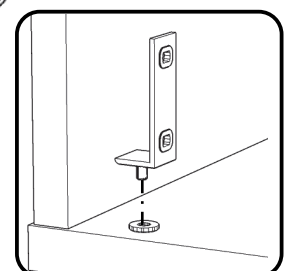

Figure 11

# Assembly Instructions 10/11

## STEP 20

Place Doors (N) and (O) face down on a soft cloth.

Attach Hinges to Doors (N) and (O) with Wood Screws into pre-drilled holes. (See Figure 12)

Attach Plates to Doors (N) and (O) with Plate Screws into pre-drilled holes. (See Figure 13)

Plate Screw  
Plate

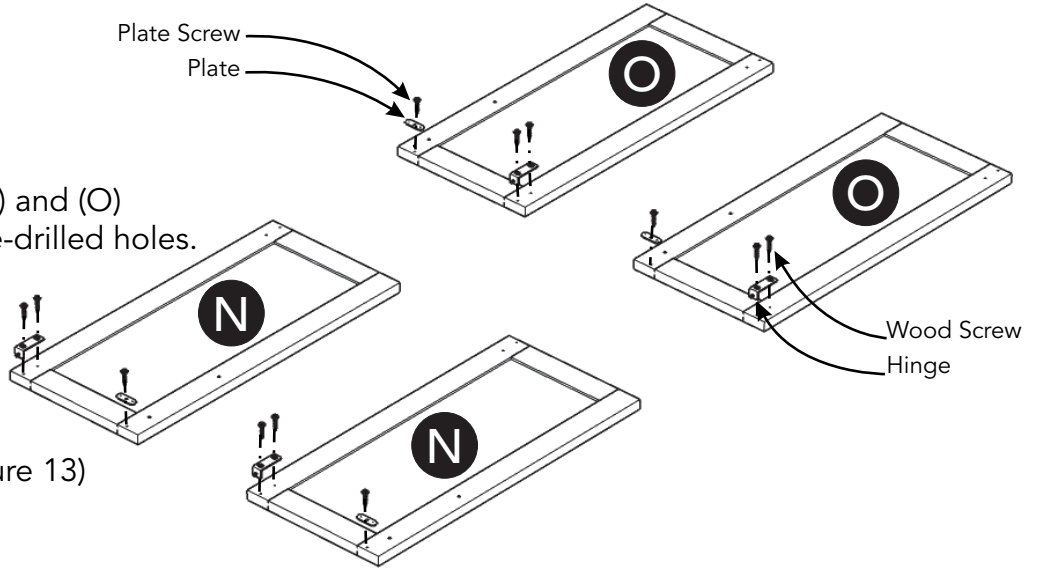

Wood Screw  
Hinge

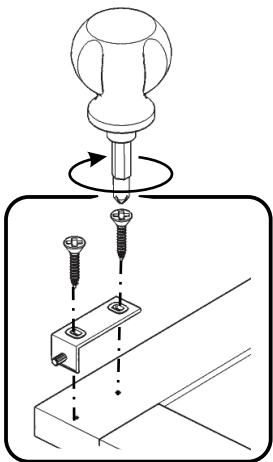

Figure 12

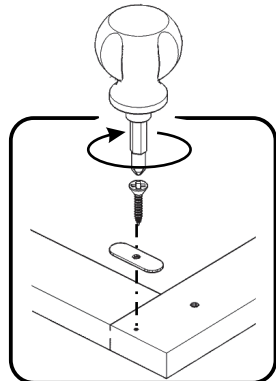

Figure 13

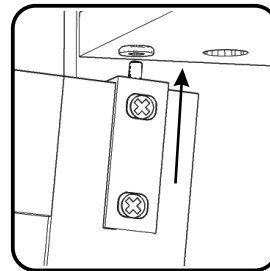

Figure 14

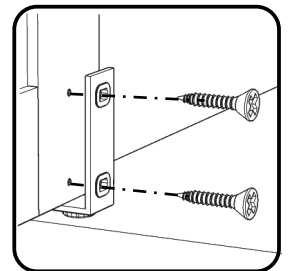
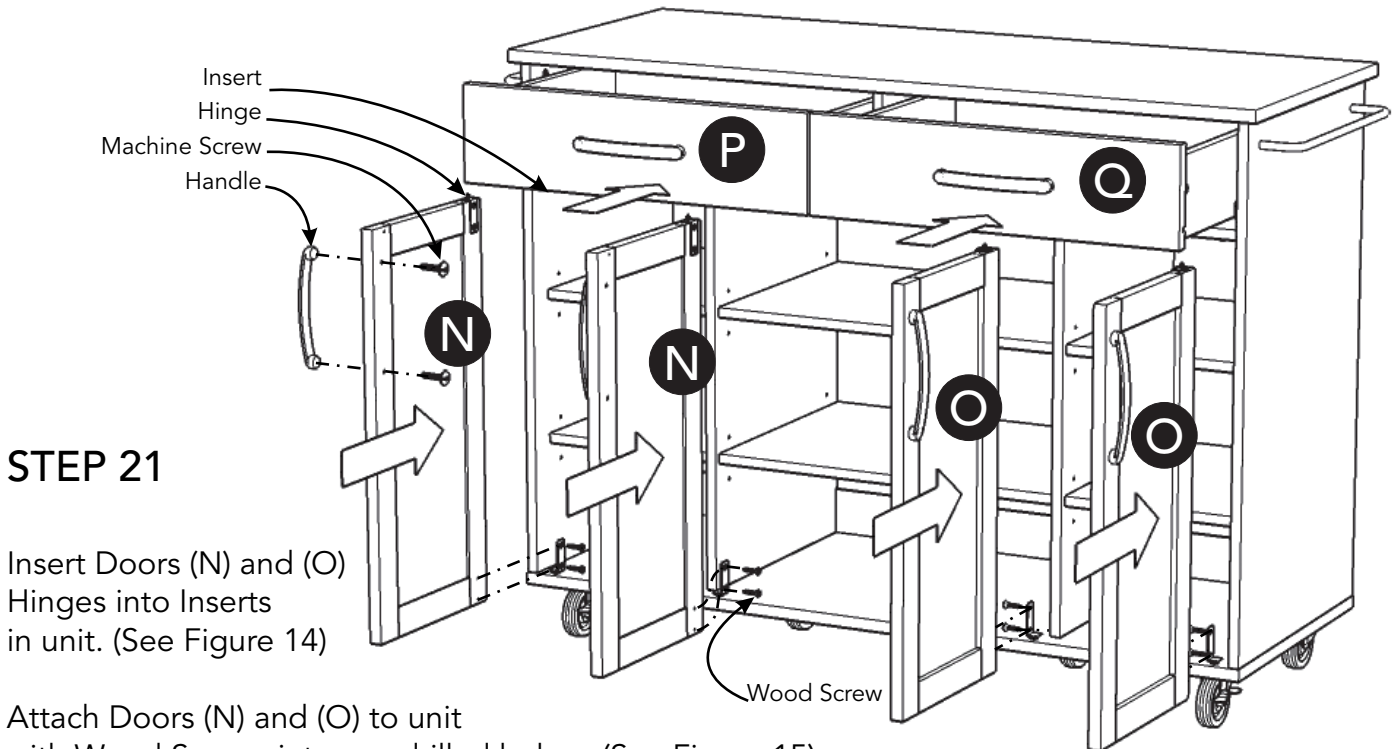

Figure 15



## STEP 21

Insert Doors (N) and (O) Hinges into Inserts in unit. (See Figure 14)

Attach Doors (N) and (O) to unit with Wood Screws into pre-drilled holes. (See Figure 15)

Attach Handles to Doors (N) and (O) with Machine Screws.

Slide Drawers (P) and (Q) into position.

# Assembly Instructions 11/11

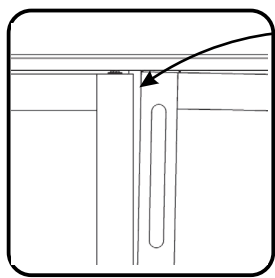
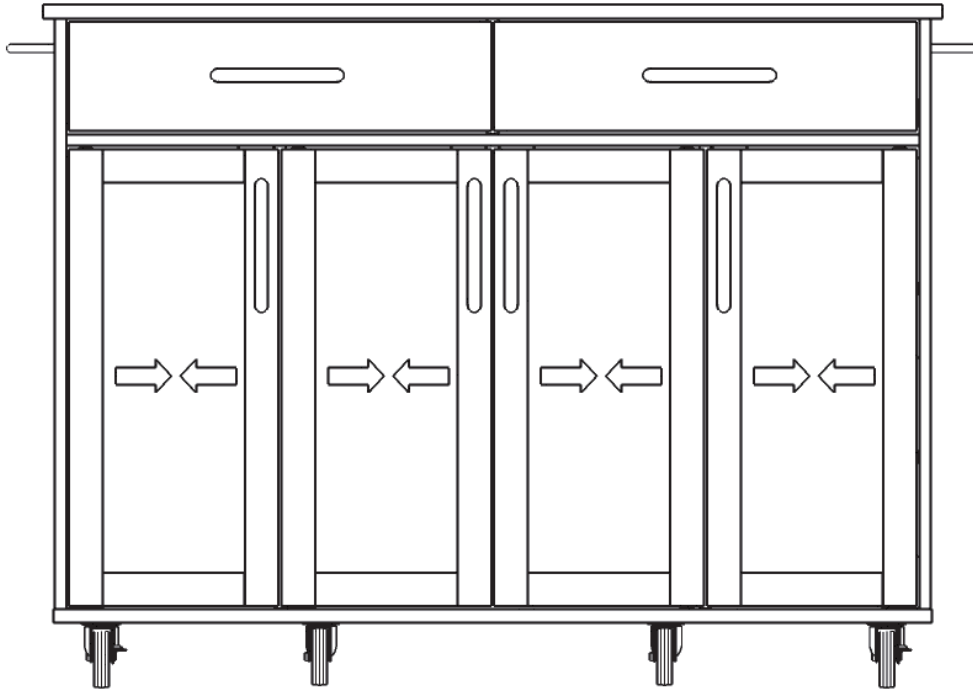

Figure 16

Uneven Gap

Large Gap

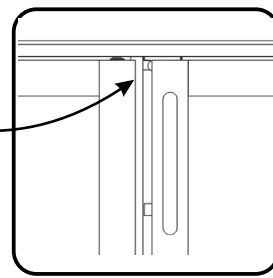

Figure 17

If needed, doors may be adjusted for large or uneven gaps between them. (See Figures 16 and 17)

Loosen Wood Screws attaching Hinge to door. (See Figure 18)

Slide door left to right as needed to adjust gap. (See Figure 19)

Re-tighten Wood Screws attaching Hinge to door. (See Figure 20)

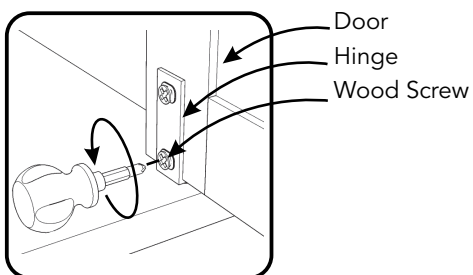

Figure 18

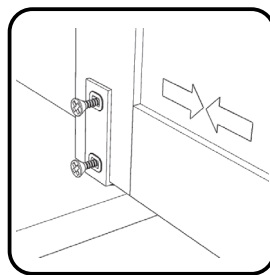

Figure 19

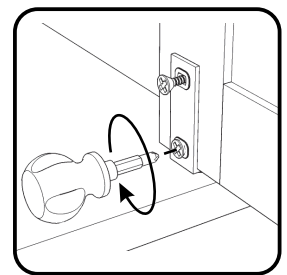

Figure 20

# CARE INSTRUCTIONS

## NEVER

allow liquids to remain on furniture.  
Absorption causes parts to warp  
and split and finishes to delaminate.

## NEVER

use glass cleaners on  
finished furniture. Ammonia  
chemically attacks the finish.



Do not use power tools  
above 8 volts to assemble.

**PREVENT  
CRACKING**



Do not place  
in direct sunlight.

**PREVENT  
FADING**



Do not write  
directly on surface.

**PREVENT  
MARKING**



Do not place hot  
objects on surface.

**PREVENT  
FINISH DAMAGE**

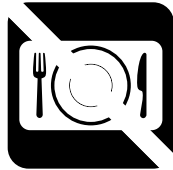

Do not use rubber  
based placemats.

**PREVENT  
DISCOLORING**



Do not use commercial  
waxes and polishes.

**PREVENT  
YELLOWING**

## CLEAN

with a soft cloth moistened  
in lukewarm soap and water.  
Buff with a dry clean cloth.

