

# ASSEMBLY INSTRUCTION

## KITCHEN ISLAND

Item NO.: KI0173

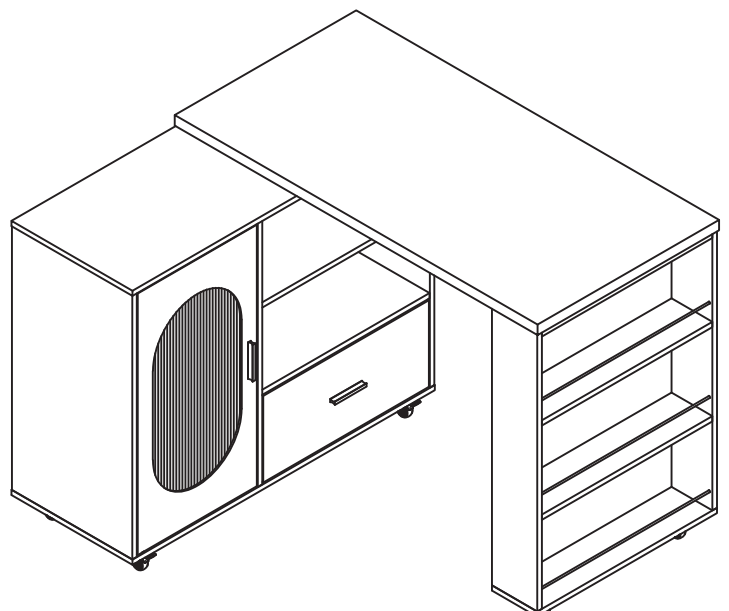

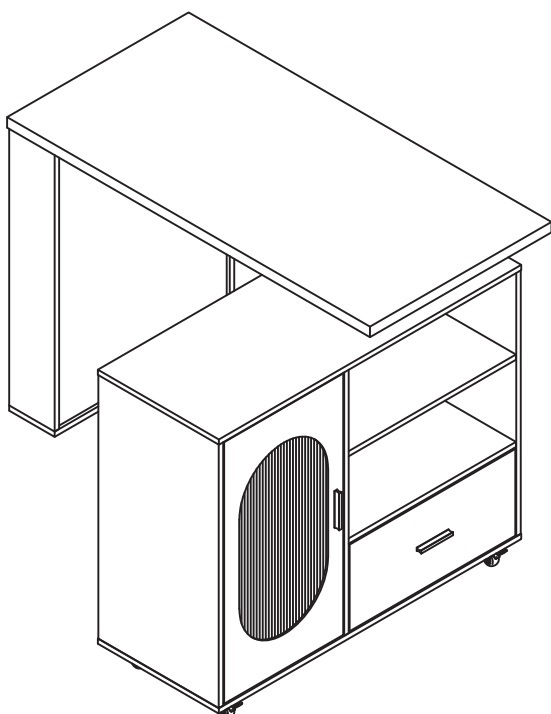
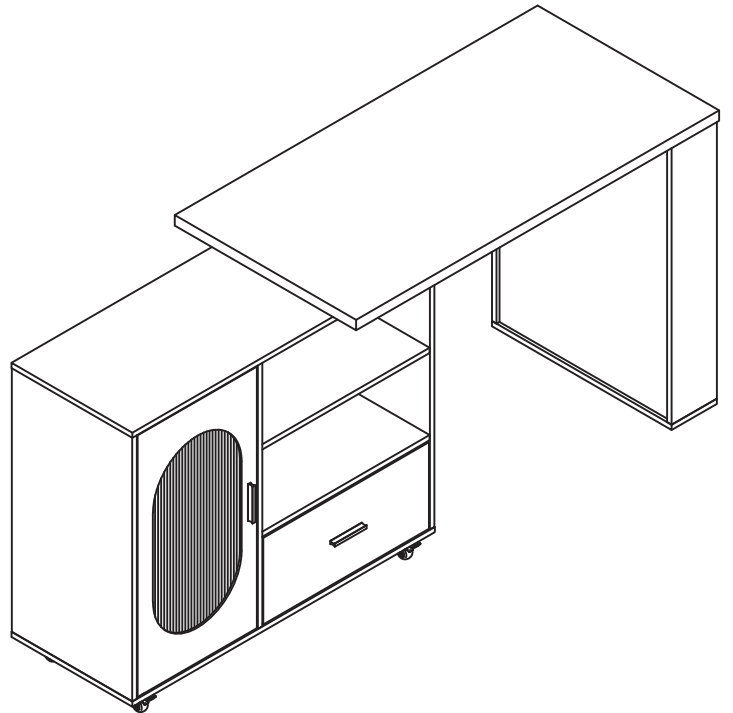
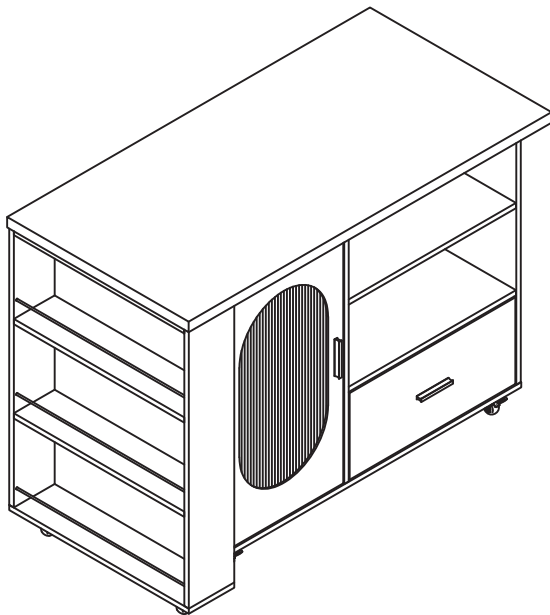

Thank you for purchasing our kitchen island. If any part is missing or damaged, please do not hesitate to contact us, we will send you the replacement immediately.

**Email: [jackye@hshfurniture.NET](mailto:jackye@hshfurniture.NET)**

## ASSEMBLY TIPS

1. Please read the Assembly Instruction first and become familiar with the parts.
2. Proper assembly of this item requires 2 people.

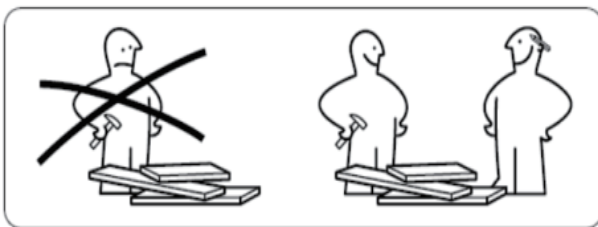

3. Unpack and assemble this unit in an spacious area, assemble the unit on top of the empty carton or carpet to prevent scratches.

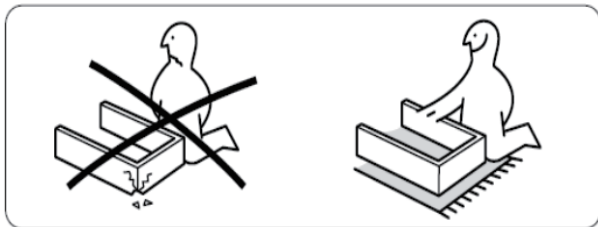

4. To avoid accidentally discarding small parts or hardware, **DO NOT** dispose of any contents until assembly is completed.
5. **Do not fully tighten all bolts until all parts are in place.** Failure to follow these instructions may cause the bolts to misalign during assembly.

## CARE INSTRUCTIONS

- (1) Hardware may loosen overtime. Periodically check that all connections are tight.
- (2) Wipe with a soft, dry cloth. To protect finish, avoid the use of chemicals and household cleaners.
- (3) All hot serving dishes should be placed on a pad.
- (4) Any liquid spilled onto the furniture should be cleaned up immediately with a dry cloth.

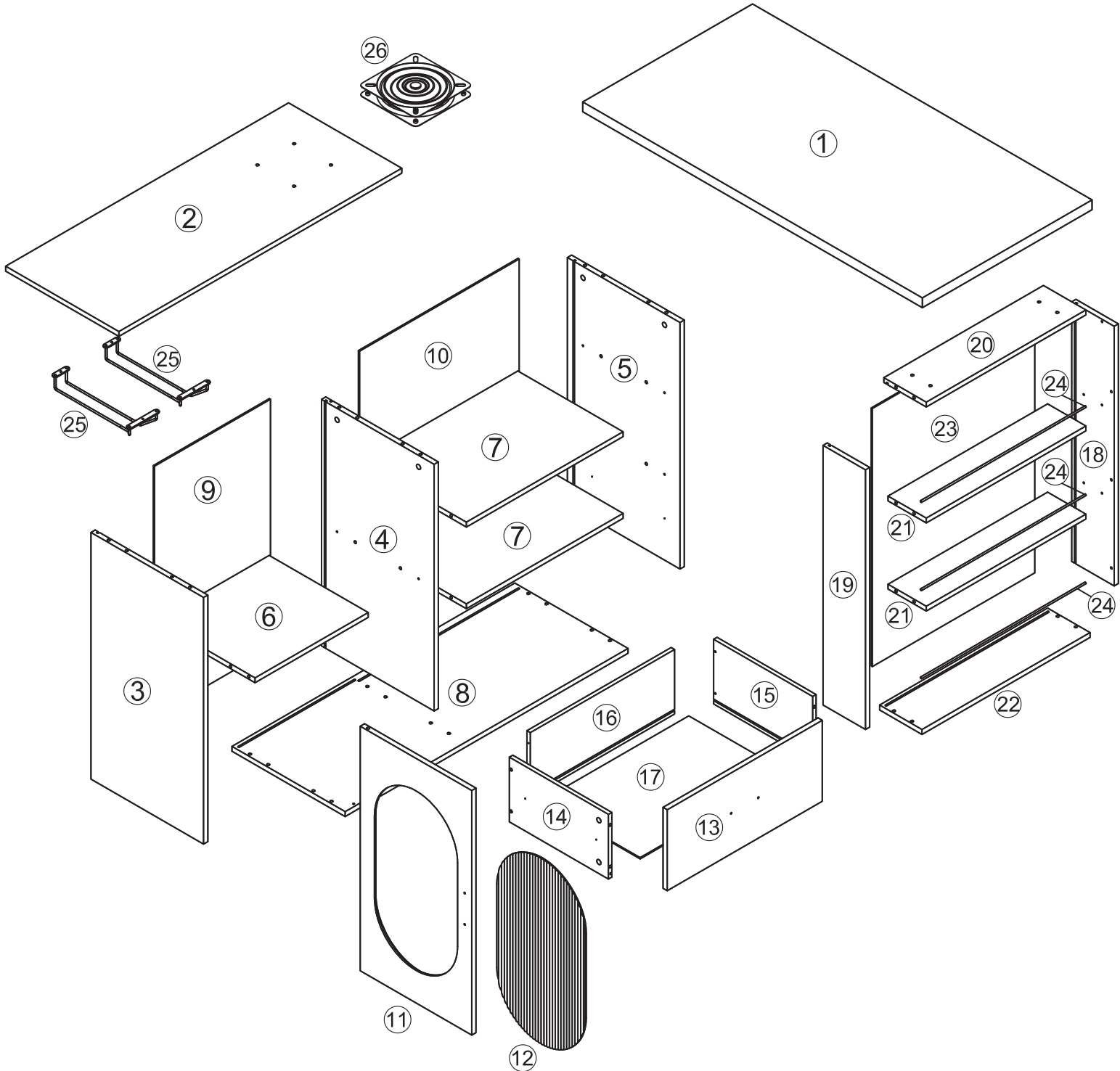

# Part Identification

 While not all parts are labeled, some of the parts will have a label to help distinguish similar parts from each other. Use this part identification to help identify similar parts.





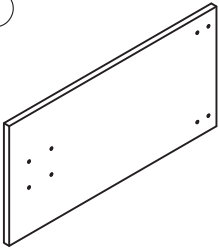
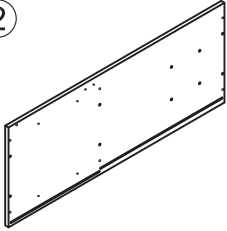
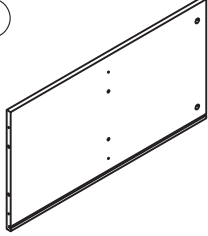
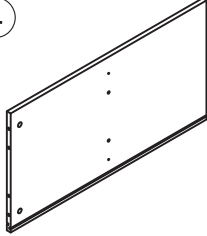
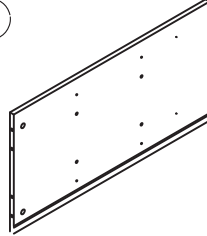
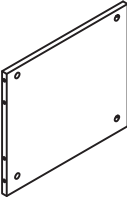
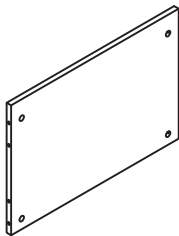
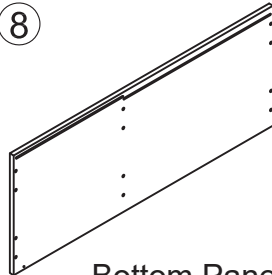
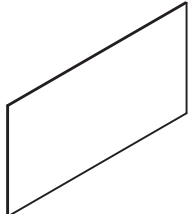
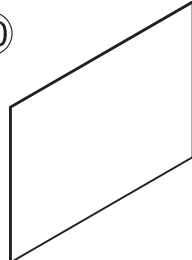
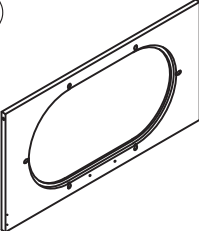
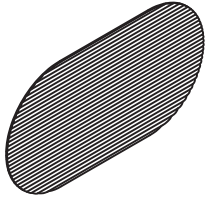
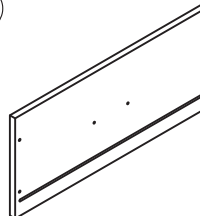
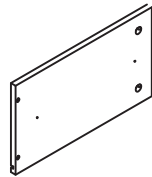
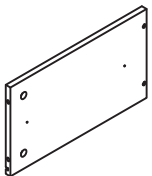
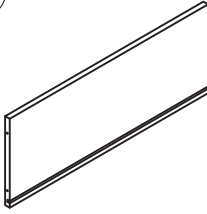
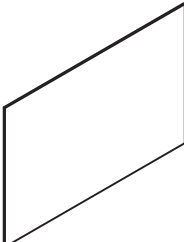
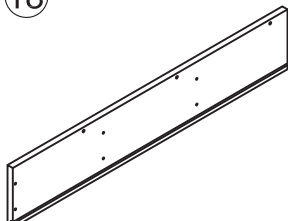
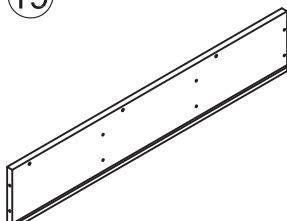
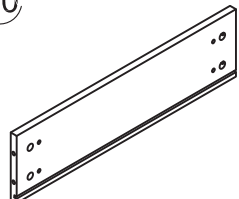
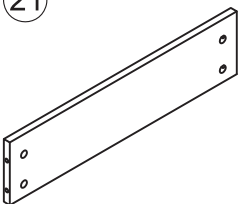
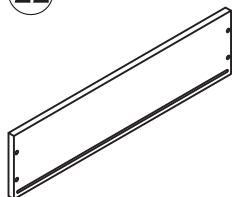
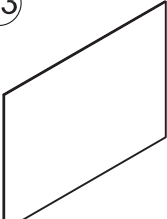
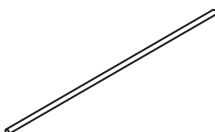
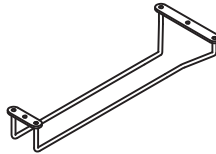



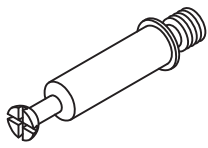
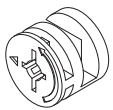

# Part Identification

 While not all parts are labeled, some of the parts will have a label to help distinguish similar parts from each other. Use this part identification to help identify similar parts.

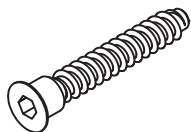
<p>①</p>  <p>Tabletop 1 PC</p>	<p>②</p>  <p>Top Panel 1 PC</p>	<p>③</p>  <p>Cabinet Panel 1 PC</p>	<p>④</p>  <p>Mid Panel 1 PC</p>	<p>⑤</p>  <p>Drawer Panel 1 PC</p>	
<p>⑥</p>  <p>Short Shelf 1 PC</p>	<p>⑦</p>  <p>Long Shelf 2 PCS</p>	<p>⑧</p>  <p>Bottom Panel 1 PC</p>	<p>⑨</p>  <p>Cabinet Back Panel 1PC</p>	<p>⑩</p>  <p>Drawer Back Panel 1PC</p>	
<p>⑪</p>  <p>Cabinet Door 1 PC</p>	<p>⑫</p>  <p>Glass Door 1PC</p>	<p>⑬</p>  <p>Drawer Front 1PC</p>	<p>⑭</p>  <p>Left Drawer Side 1PC</p>	<p>⑮</p>  <p>Right Drawer Side 1PC</p>	
<p>⑯</p>  <p>Drawer Rear 1PC</p>	<p>⑰</p>  <p>Drawer Bottom Panel 1PC</p>	<p>⑱</p>  <p>Right Side Panel 1PC</p>	<p>⑲</p>  <p>Left Side Panel 1PC</p>	<p>⑳</p>  <p>Top Shelf 1 PC</p>	
<p>㉑</p>  <p>Mid Shelf 2 PCS</p>	<p>㉒</p>  <p>Bottom Shelf 1 PC</p>	<p>㉓</p>  <p>Shelf Back Panel 1 PC</p>	<p>㉔</p>  <p>Metal Tube 3 PCS</p>	<p>㉕</p>  <p>Glass Rack 2 PCS</p>	<p>㉖</p>  <p>Swivel Base 1 PC</p>

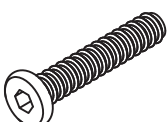
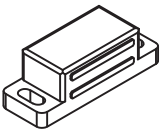
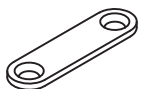
# Part Identification

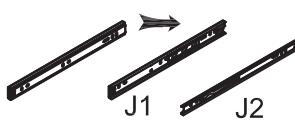
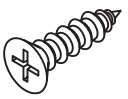
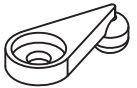
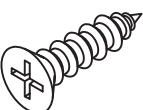
 While not all parts are labeled, some of the parts will have a label to help distinguish similar parts from each other. Use this part identification to help identify similar parts.

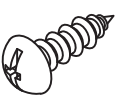
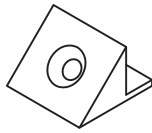
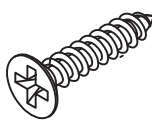
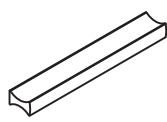
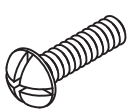
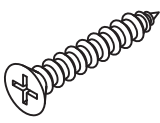
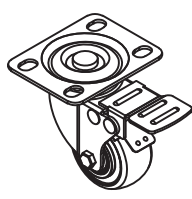
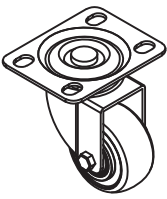
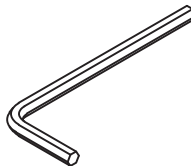
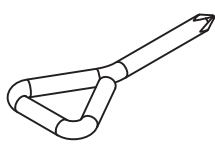
<p><b>A</b></p>  <p>Cam Bolt Ø6*45mm 34PCS</p>	<p><b>B</b></p>  <p>Cam Lock Ø15*9.5mm 34PCS</p>	<p><b>C</b></p>  <p>Wood Dowel Ø8*30 24PCS</p>	<p><b>D</b></p>  <p>Long Bolt M7*50mm 10PCS</p>	<p><b>E</b></p>  <p>Short Bolt M6*12mm 32PCS</p>
<p><b>F</b></p>  <p>Medium Bolt M6*30mm 8PCS</p>	<p><b>G</b></p>  <p>Magnetic Catch 1 PC</p>	<p><b>H</b></p>  <p>Magnetic Fitting 1 PC</p>	<p><b>I</b></p>  <p>Magnetic Screw Ø3.5*16mm 2PCS</p>	<p><b>J</b></p>  <p>Slide 2PCS</p>
<p><b>K</b></p>  <p>Slide Screw Ø3*12mm 10PCS</p>	<p><b>L</b></p>  <p>Corner Bracket 6 PCS</p>	<p><b>M</b></p>  <p>Bracket Screw Ø3.5*12mm 6PCS</p>	<p><b>N</b></p>  <p>Plug 2PCS</p>	<p><b>O</b></p>  <p>Glass Rack Screw Ø4*16mm 4PCS</p>
<p><b>P</b></p>  <p>Panel Fastener 24 PCS</p>	<p><b>Q</b></p>  <p>Fastener Screw Ø3.5*16mm 24 PCS</p>	<p><b>R</b></p>  <p>Handle 2 PCS</p>	<p><b>S</b></p>  <p>Handle Bolt Ø4*18mm 4PCS</p>	<p><b>T</b></p>  <p>Drawer Screw Ø4*35mm 4PCS</p>
<p><b>U</b></p>  <p>Brake Caster 4 PCS</p>	<p><b>V</b></p>  <p>Swivel Caster 3 PCS</p>	<p><b>W</b></p>  <p>Allen Key M4 1PC</p>	<p><b>X</b></p>  <p>Screwdriver 1 PC</p>	

# Hardware Usage Guide

## HOW TO USE A CAM BOLT & CAM LOCK.

1.



Cam Bolt

Clockwise rotate the CAM BOLT until the shoulder is against the surface of the board.

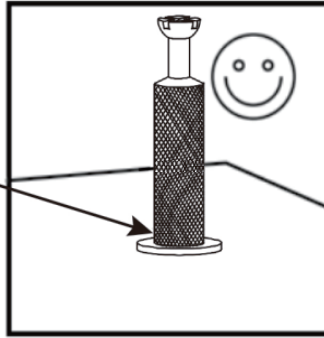

RIGHT



WRONG

2.

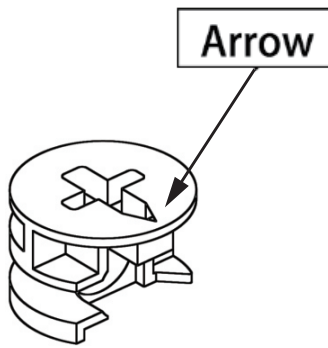

Cam Lock

Push a CAM LOCK into the board. The arrow in the CAM LOCK must point toward the hole in the edge of the board.

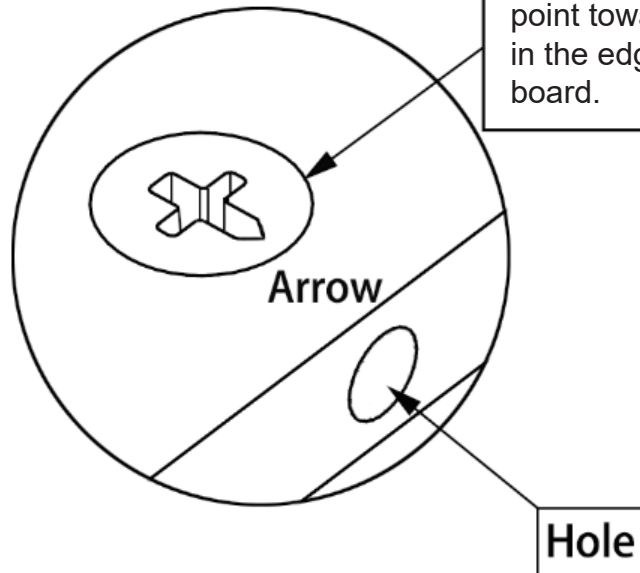

3. Insert the CAM BOLT into the CAM LOCK. Clockwise rotate to tighten the CAM LOCK.

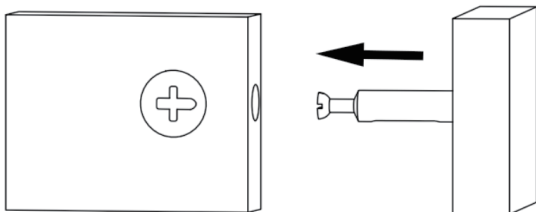

3.1

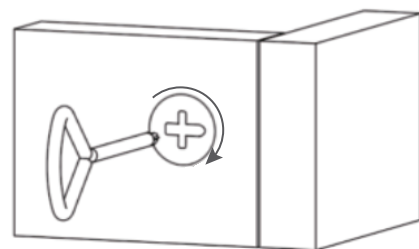

3.2

# Step 01

Product support email: [jackye@hshfurniture.NET](mailto:jackye@hshfurniture.NET)

- 1 Pull the Inner Slide (J2) out from the assembly Slide (J) until it reaches the stopping position, Then, press the latch on the Inner Slide (J2) to slide it out from the Outer Slide (J1). Repeat this step twice. Make sure all two sets are properly separated before moving to the next step.

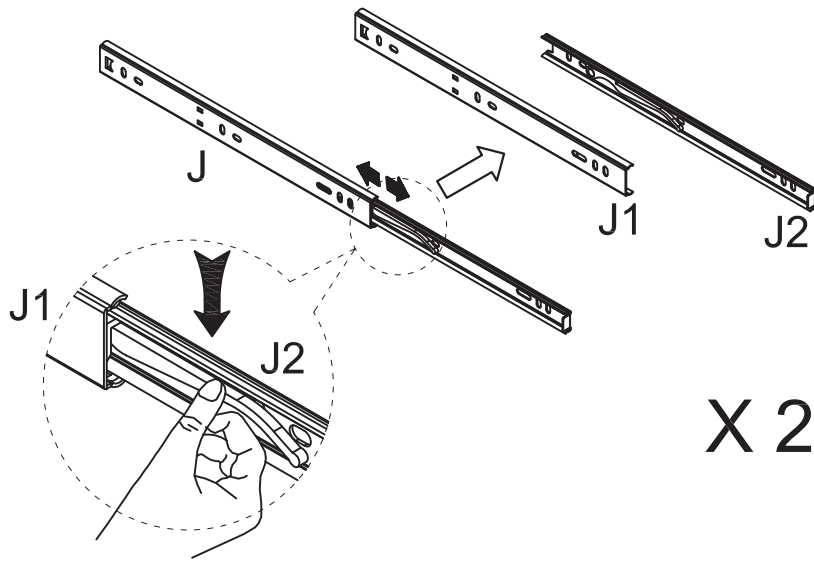

# Step 02

NOTE: All bolts must be fully tightened at this step.  
Product support email: [jackye@hshfurniture.NET](mailto:jackye@hshfurniture.NET)

- 2.1 Insert and tighten four Cam Bolts (A) into the holes on Mid Panel (④) by Screwdriver(X). Attach one Outer Slide (J1) to Mid Panel (④) using two Slide Screws (K) with Screwdriver (X). Please ensure that the large plastic front end of the slide is kept away from the groove on Mid Panel (④). Move the slide block away before locking to prevent the slide block from being fixed and rendering the slide unusable.
- 2.2 Carefully turn the installed Mid Panel (④) over 180° as shown, then insert and tighten two Cam Bolts (A) and four Wood Dowels (C) into Mid Panel (④) by Screwdriver(X). All Bolts must be fully tightened at this step.

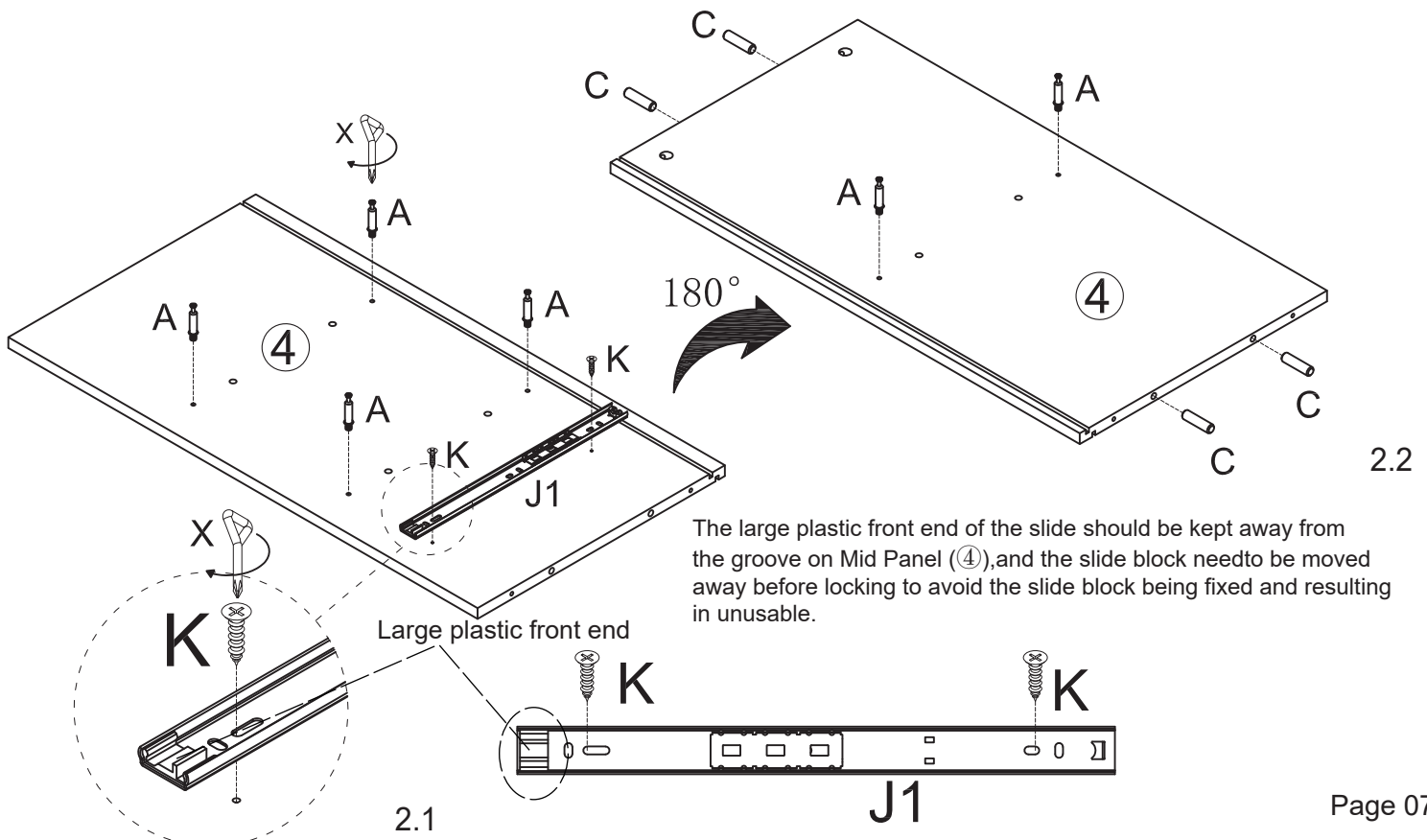

# Step 03

NOTE: All bolts must be fully tightened at this step.  
Product support email: [jackye@hshfurniture.NET](mailto:jackye@hshfurniture.NET)

- 3.1 Insert and screw two Cam Bolts (A) and four Wood Dowels (C) into Cabinet Panel(③) by Screwdriver(X).
- 3.2 Insert and screw four Cam Bolts (A) and four Wood Dowels ( C ) into Drawer Panel ( ⑤ ) by Screwdriver (X). Then,connect and fasten Outer Slide (J1) to Drawer Panel ( ⑤ ) using two Slide Screws (K) with Screwdriver (X). Please ensure that the large plastic front end of the slide is kept away from the groove on the Drawer Panel (⑤), and move the slide block away before locking to prevent the slide block from being fixed and rendering the slide unusable.

The large plastic front end of the slide is kept away from the groove on the Drawer Panel (⑤), and move the slide block away before locking.

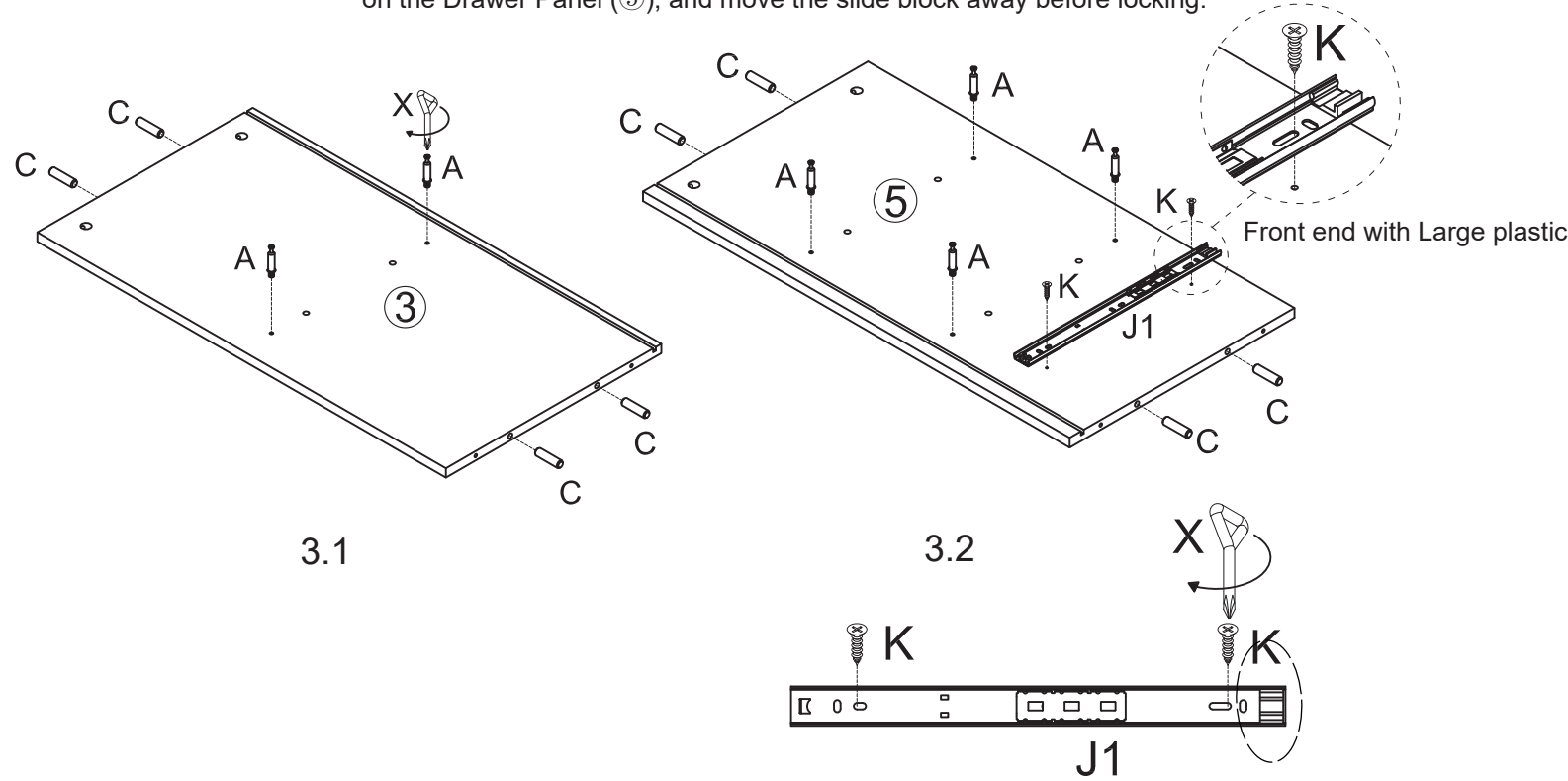

# Step 04

Product support email: [jackye@hshfurniture.NET](mailto:jackye@hshfurniture.NET)

- 4.1 Insert four wood dowels (C) into the four edge holes of long shelf (⑦), repeat it for another long shelf (⑦).
- 4.2 Insert four wood dowels (C) into the four edge holes of Short shelf (⑥).

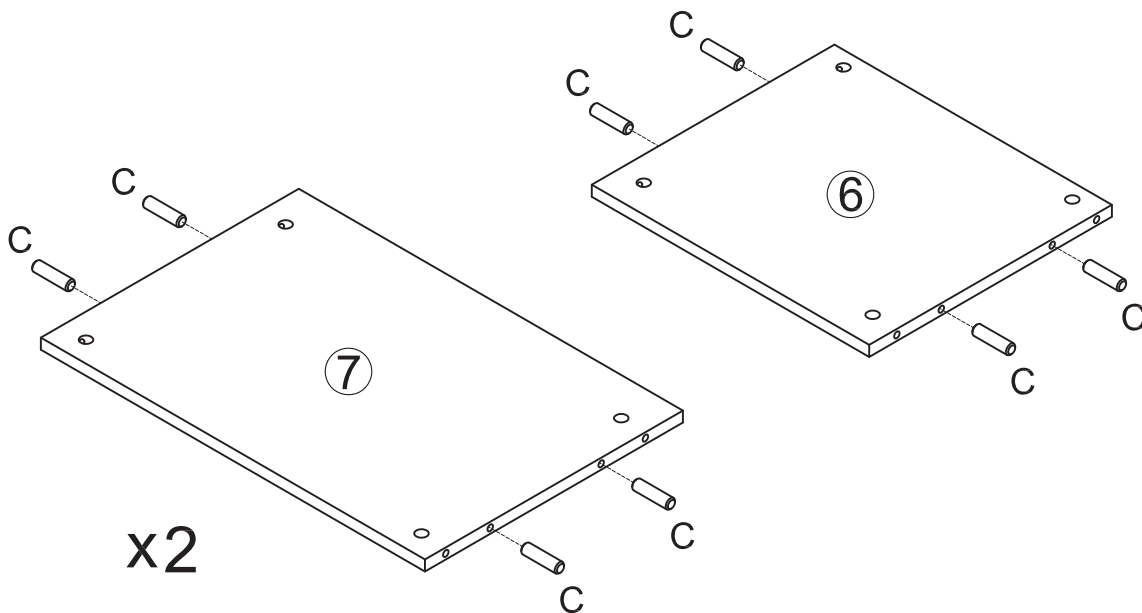

# Step 05

NOTE: All bolts must be fully tightened at this step.  
Product support email: [jackye@hshfurniture.NET](mailto:jackye@hshfurniture.NET)

- 5 Attach two Long Shelves (7) to Drawer Panel (5) and Mid Panel (4). Align the Cam Bolts (A) on Drawer Panel (5) and Mid Panel (4) with the designated holes on two Long Shelves (7), Insert each four Cam Locks (B) into the holes on two Long Shelves (7), make sure the arrow on cam Lock (B) points to Cam Bolt (A), and then tightened by turning Screwdriver (X) clockwise. Please ensure the grooves of Panels (5)(4) are facing upwards and two slides are facing inward; And the holes on two Long Shelves (7) away from the edge are facing downwards so that the bottom edge will be flush with the bottom edges of Drawer Panel (5) and Mid Panel (4) after installation.

The grooves of Panels (5)(4) are facing upwards and the slides are facing inward

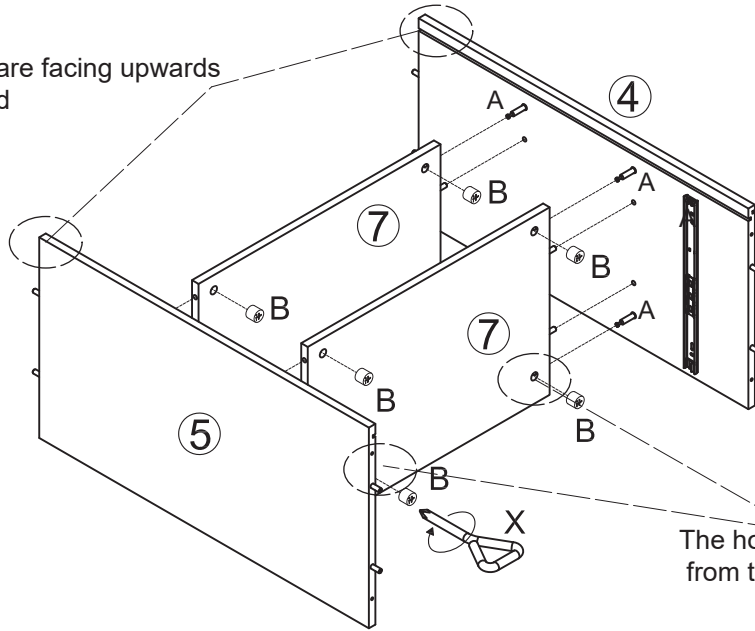

The holes on two Long Shelves (7) away from the edge are facing downwards

# Step 06

NOTE: All bolts must be fully tightened at this step.  
Product support email: [jackye@hshfurniture.NET](mailto:jackye@hshfurniture.NET)

- 6 Align the Cam Bolts (A) on Mid Panel (4) and Cabinet Panel (3) with the designated holes on Short Shelf (6), Insert four Cam Locks (B) into the holes on Short Shelf (6), make sure the arrow on cam Lock (B) points to Cam Bolt (A), and then tightened by turning Screwdriver (X) clockwise. Please ensure that the holes on Short Shelf (6) away from the edge should face upwards and the side with groove on Cabinet Panel (3) is in the same plane as Mid Panel (4) and face inward.

The side with groove on Cabinet Panel (3) is in the same plane as Mid Panel (4) and facing inward.

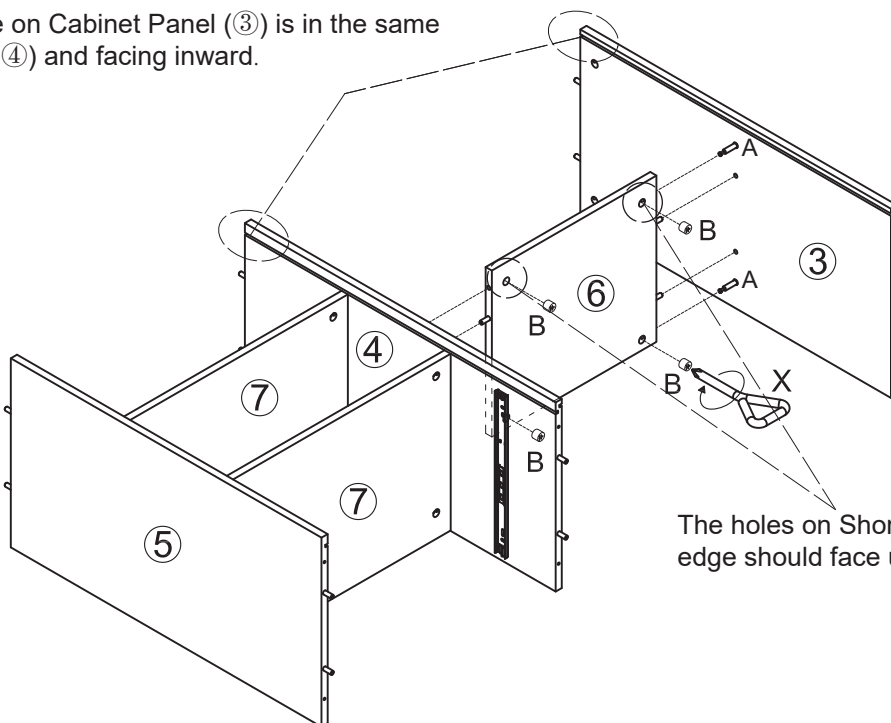

The holes on Short Shelf (6) away from the edge should face upwards.

# Step 07

NOTE: All bolts must be fully tightened at this step.  
Product support email: [jackye@hshfurniture.NET](mailto:jackye@hshfurniture.NET)

- 7.1 Insert and tighten six Cam Bolts (A) into Top Panel (2) by Screwdriver (X). Then, place and secure Magnetic Catch (G) into Top Panel (2) using two Magnetic Screws (I) by Screwdriver (X). Please ensure that the magnetic should face outward.
- 7.2 Fasten two Glass Racks (25) to Top Panel (2) using four Glass Rack Screws (O) by Screwdriver (X). Please ensure that the wide end of Glass Racks (25) towards the magnetic touch direction. All bolts must be fully tightened at this step.

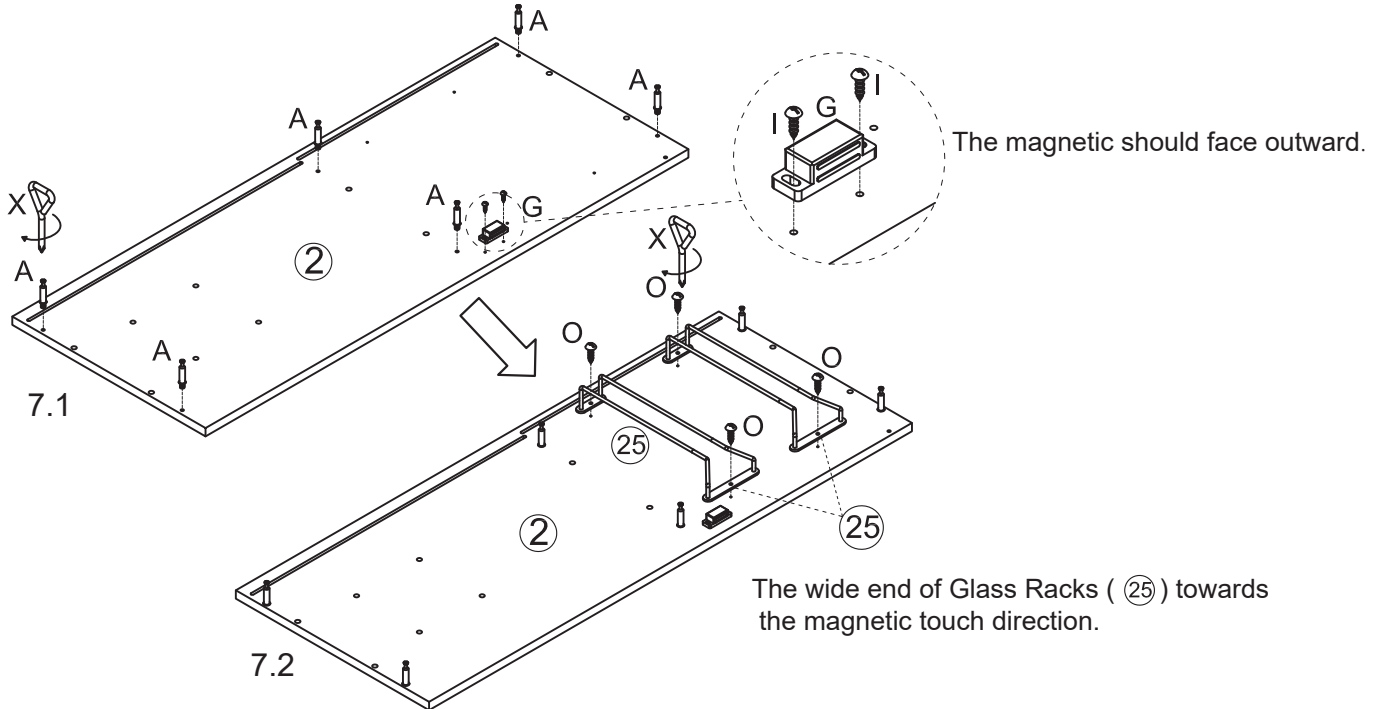

# Step 08

NOTE: All bolts must be fully tightened at this step.  
Product support email: [jackye@hshfurniture.NET](mailto:jackye@hshfurniture.NET)

- 8 Align the Cam Bolts (A) on Top Panel (2) with the designated holes on panels (3) (4) (5), Insert six Cam Locks (B) into the holes on panels (3) (4) (5), make sure the arrow on Cam Lock (B) points to Cam Bolt (A), and then tightened by turning Screwdriver (X) clockwise. All bolts must be fully tightened at this step.

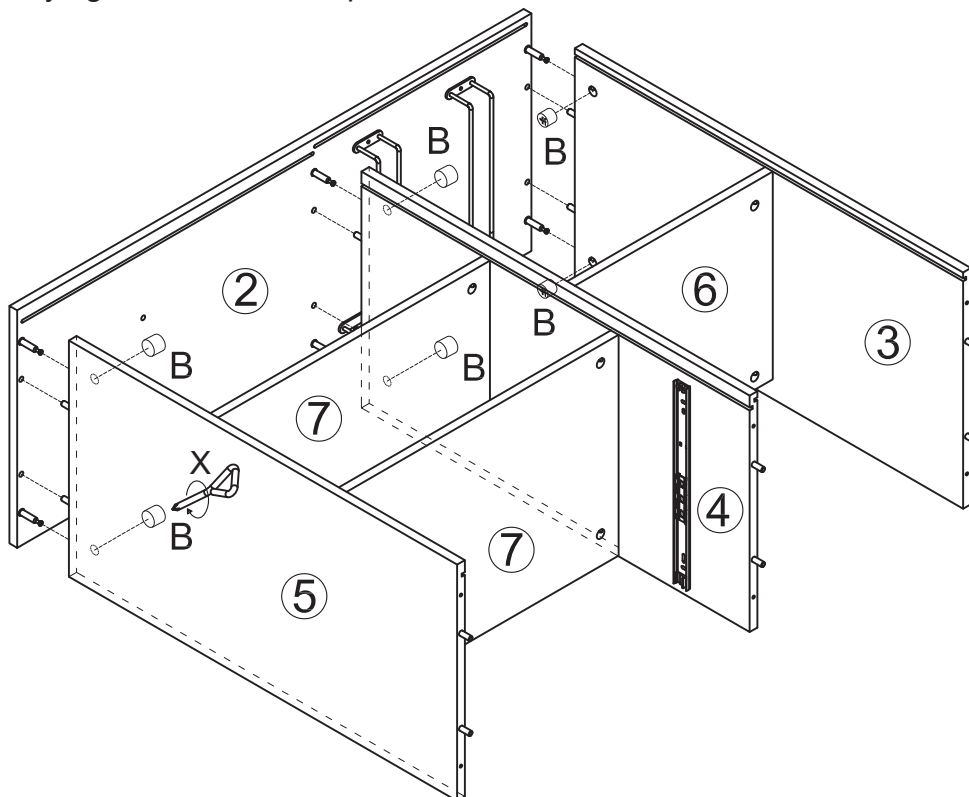

- 9** Insert Cabinet Back Panel (9) and Drawer Back Panel (10) between the Cabinet Panel (3), Mid Panel (4) and Drawer Panel (5) along the grooves as picture shown.

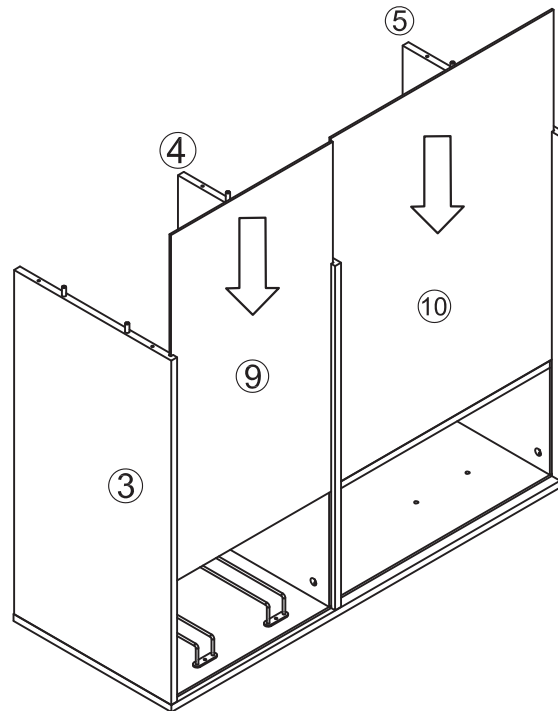

# Step 10

**NOTE:** All bolts must be fully tightened at this step.

Product support email: [jackye@hshfurniture.NET](mailto:jackye@hshfurniture.NET)

- 10** Place the Bottom Panel (8) onto the pre-assembled cabinet structure, Connect and secure Bottom Panel (8) to Panels (3 4 5) using six Long Bolts (D) by Allen Key(W). All bolts must be fully tightened at this step.

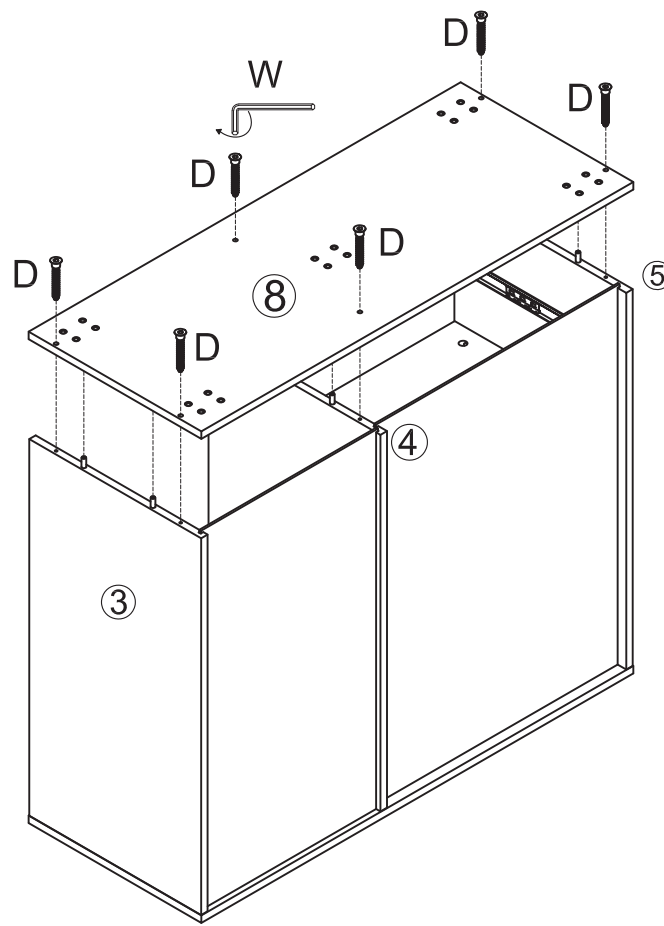

# Step 11

NOTE: All bolts must be fully tightened at this step.

Product support email: [jackye@hshfurniture.NET](mailto:jackye@hshfurniture.NET)

- 11** Attach two Brake Casters (U) and three Swivel Casters (V) to the designated locations of Bottom Panel (8) using twenty Short Bolts (E) by Allen Key (W) as shown. All bolts must be fully tightened at this step.

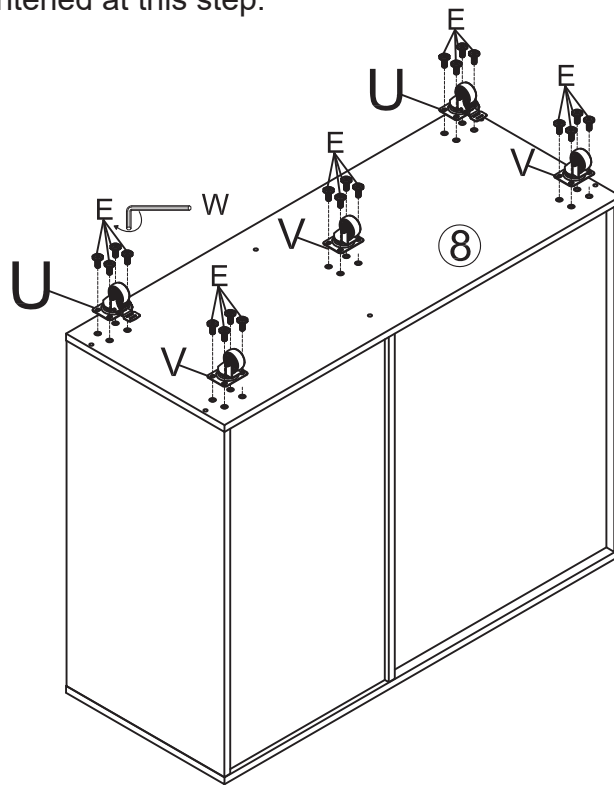

# Step 12

NOTE: All bolts must be fully tightened at this step.

Product support email: [jackye@hshfurniture.NET](mailto:jackye@hshfurniture.NET)

- 12.1** Position and attach Inner Slides (J2) to Left Drawer Side (14) using two Slide Screws (K), tighten by Screwdriver (X).
- 12.2** Position and attach Inner Slides (J2) to Right Drawer Side (15) using two Slide Screws (K), tighten by Screwdriver (X).
- Please ensure that the U-shaped opening end of the slides is in the position on the side with two small holes on the panels.

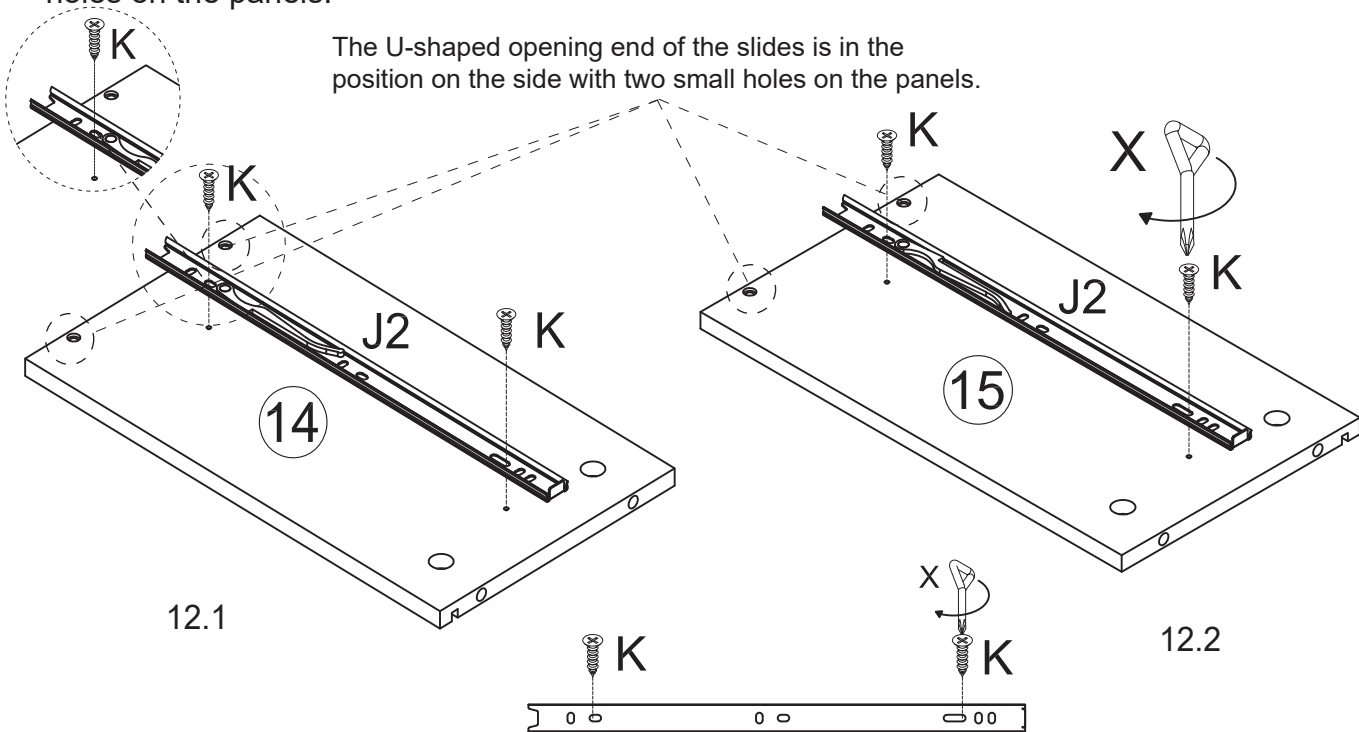

# Step 13

NOTE: All bolts must be fully tightened at this step.  
Product support email: [jackye@hshfurniture.NET](mailto:jackye@hshfurniture.NET)

- 13.1 Connect and fasten Left Drawer Side (14) and Right Drawer Side (15) to Drawer Rear (16) with four Drawer Screws (T) by Screwdriver (X). Make sure three slots on these three panels are in the same compartment and close to the ground.
- 13.2 Insert Drawer Bottom Panel (17) between the Left Drawer Side (14) and Right Drawer Side (15) along slots.
- All bolts must be fully tightened at this step.

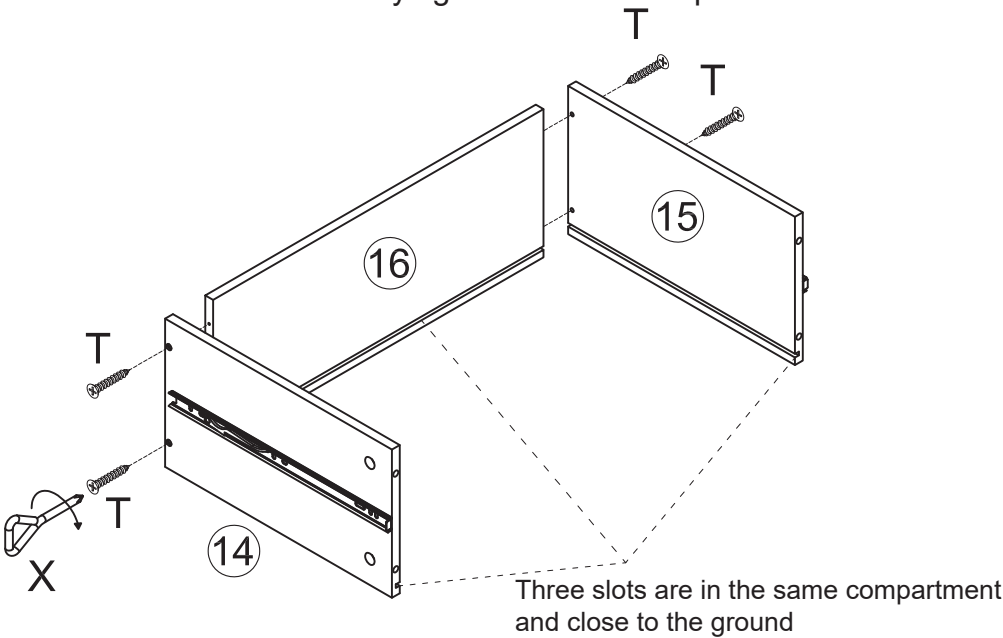

13.1

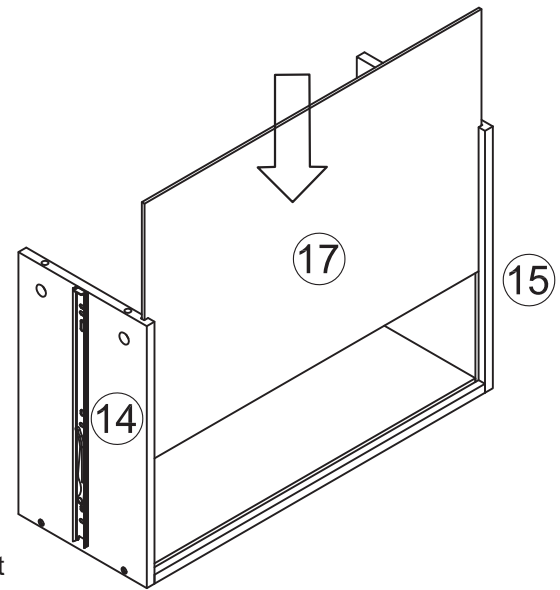

13.2

# Step 14

NOTE: All bolts must be fully tightened at this step.  
Product support email: [jackye@hshfurniture.NET](mailto:jackye@hshfurniture.NET)

- 14.1 Insert and screw four Cam Bolts (A) into the holes on Drawer Front (13) by Screwdriver (X). Then, Align the Cam Bolts (A) on Drawer Front (13) with the designated holes on Drawer Side (14 15), Insert four Cam Locks (B) into the holes on Drawer Side (14 15), make sure the arrow on cam Lock (B) points to Cam Bolt (A), and then tightened by turning Screwdriver (X) clockwise.
- 14.2 Attach and fasten Handle (R) to Drawer Front (13) with two Handle Bolts (S) by Screwdriver (X). All bolts must be fully tightened at this step.

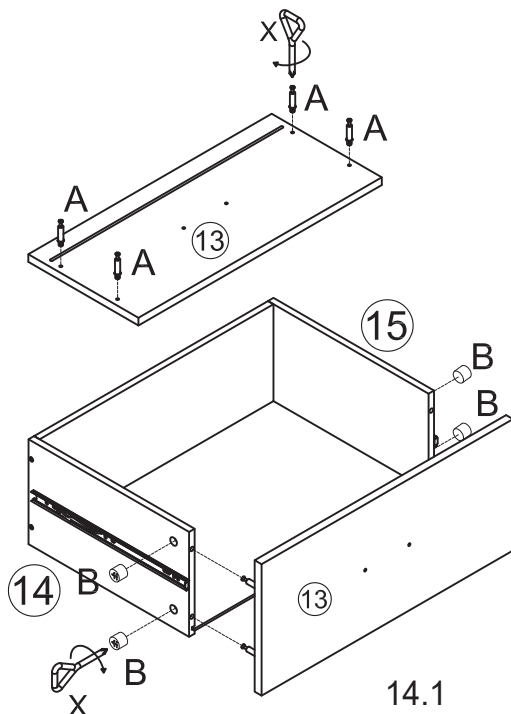

14.1

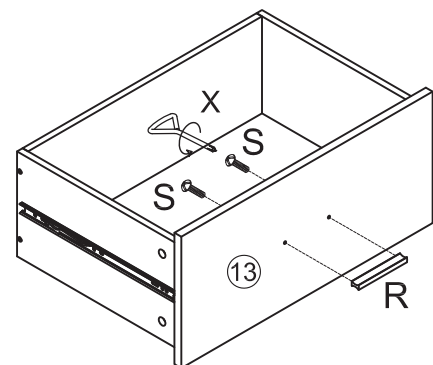

14.2

# Step 15

Product support email: [jackye@hshfurniture.NET](mailto:jackye@hshfurniture.NET)

- 15** Place the Glass Door (12) into the Cabinet Door (11), ensuring it is properly aligned and seated. Once positioned, attach the six Corner Brackets (L) around the edges of the glass using six Bracket Screws (M) with Screwdriver (X). Then, install the Magnet Fitting (H) to the Cabinet Door (11) using two Slide Screws (K) with Screwdriver (X). Ensure all components are securely fastened.

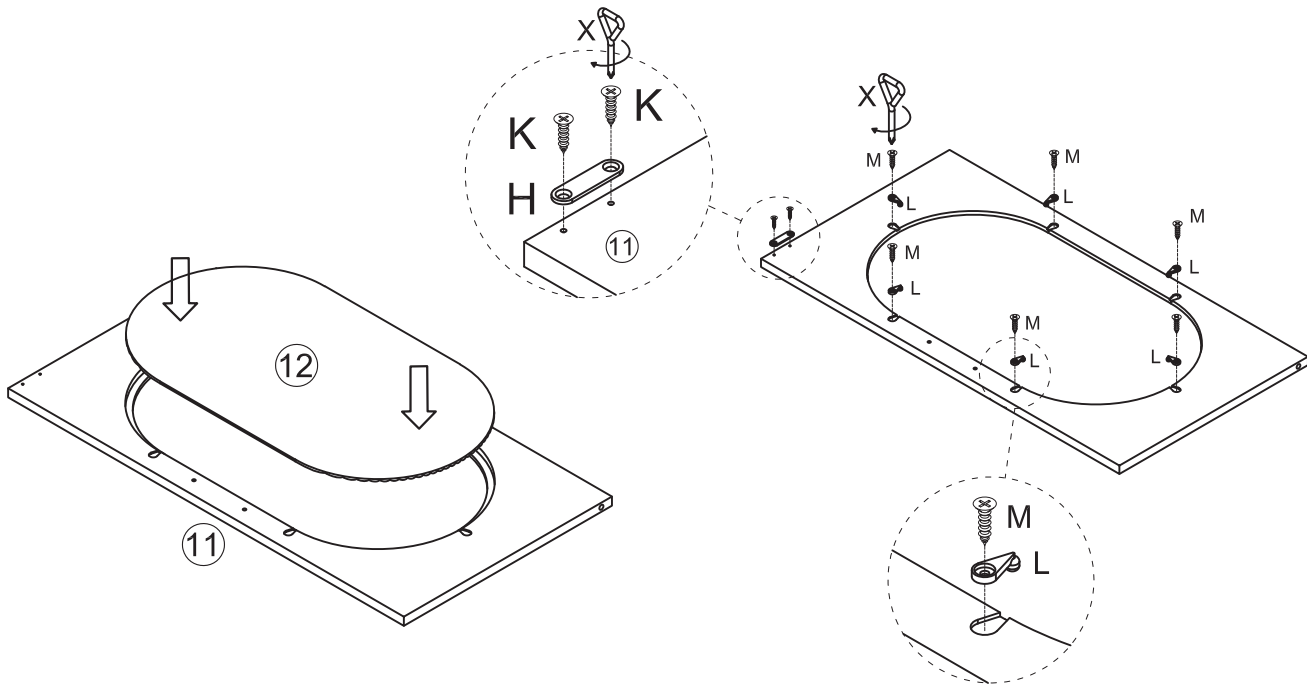

# Step 16

NOTE: All bolts must be fully tightened at this step.

Product support email: [jackye@hshfurniture.NET](mailto:jackye@hshfurniture.NET)

- 16** Attach the Handle (R) to the Cabinet Door (11) using two Handle Bolts (S) with Screwdriver (X). Then, insert two Plugs (N) into the pre-drilled holes on the top and bottom edges of the Cabinet Door (11). Ensure all components are properly aligned and all bolts must be fully tightened at this step.

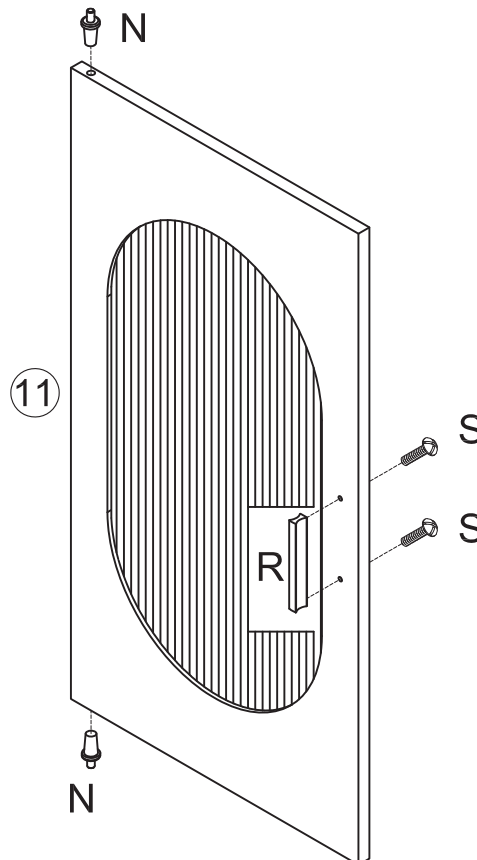

# Step 17

Product support email: [jackye@hshfurniture.NET](mailto:jackye@hshfurniture.NET)

- 17** Moving the bead channel on the Outer Slide (J1) to the outermost end. Then, align Inner Slide (J2) with the grooves of the Outer Slide (J1) and push it inward to connect the two components securely. Ensure that the slides are correctly aligned and fully engaged for smooth drawer operation.

Moving the bead channel on the Outer Slide (J1) to the outermost end.

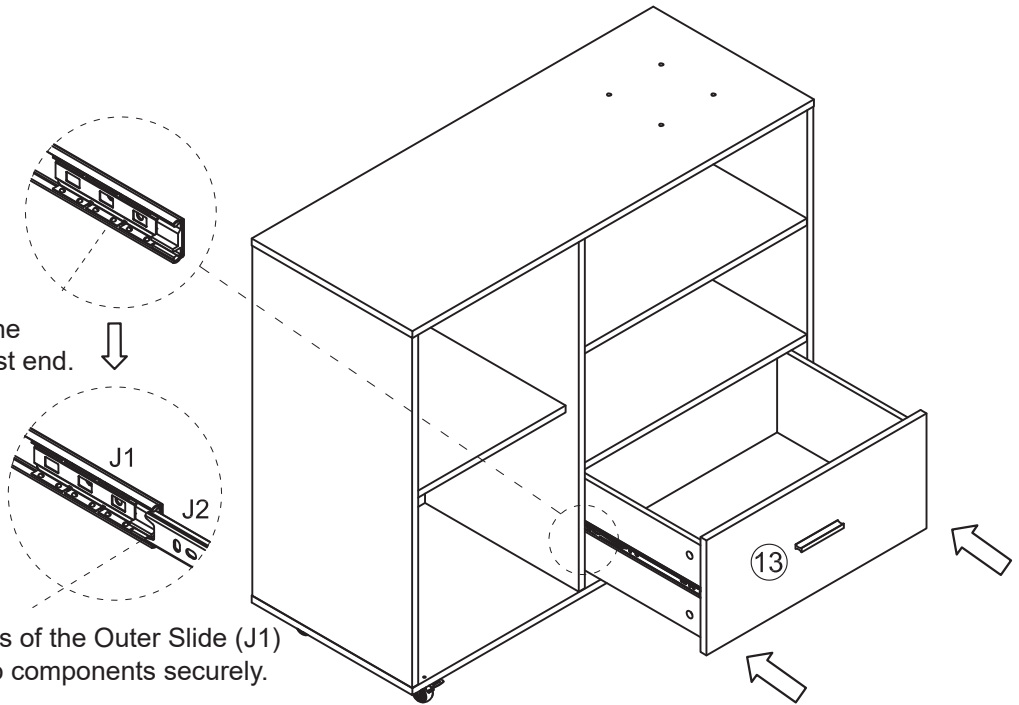

Align Inner Slide (J2) with the grooves of the Outer Slide (J1) and push it inward to connect the two components securely.

# Step 18

Product support email: [jackye@hshfurniture.NET](mailto:jackye@hshfurniture.NET)

- 18** Insert bottom pin of Cabinet Door (11) into the hole on Bottom Panel (8), then press the upper pin of Cabinet Door (11) flat and then insert it into the hole on Top Panel (2). Check that the door opens and closes smoothly and is properly aligned with the cabinet. Adjust if necessary to ensure the door operates correctly and securely.

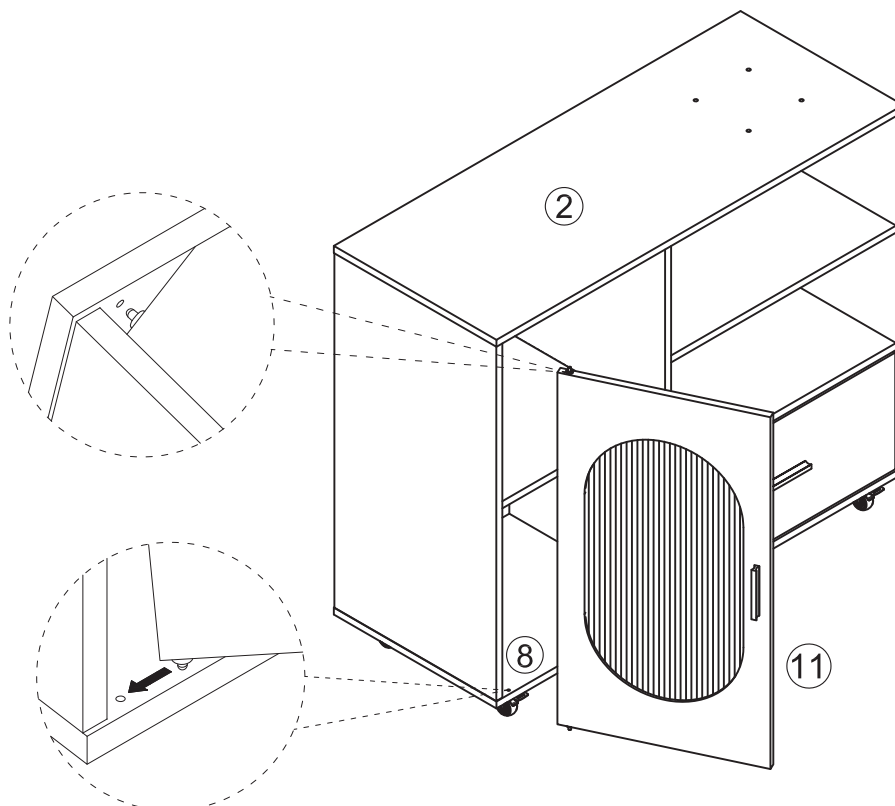

# Step 19

NOTE: All bolts must be fully tightened at this step.

Product support email: [jackye@hshfurniture.NET](mailto:jackye@hshfurniture.NET)

- 19** Insert and screw each six Cam Bolts (A) into the designated holes on Left Side Panel ( 19 ) and Right Side Panel ( 18 ) using Screwdriver (X). All Bolts must be fully tightened at this step.

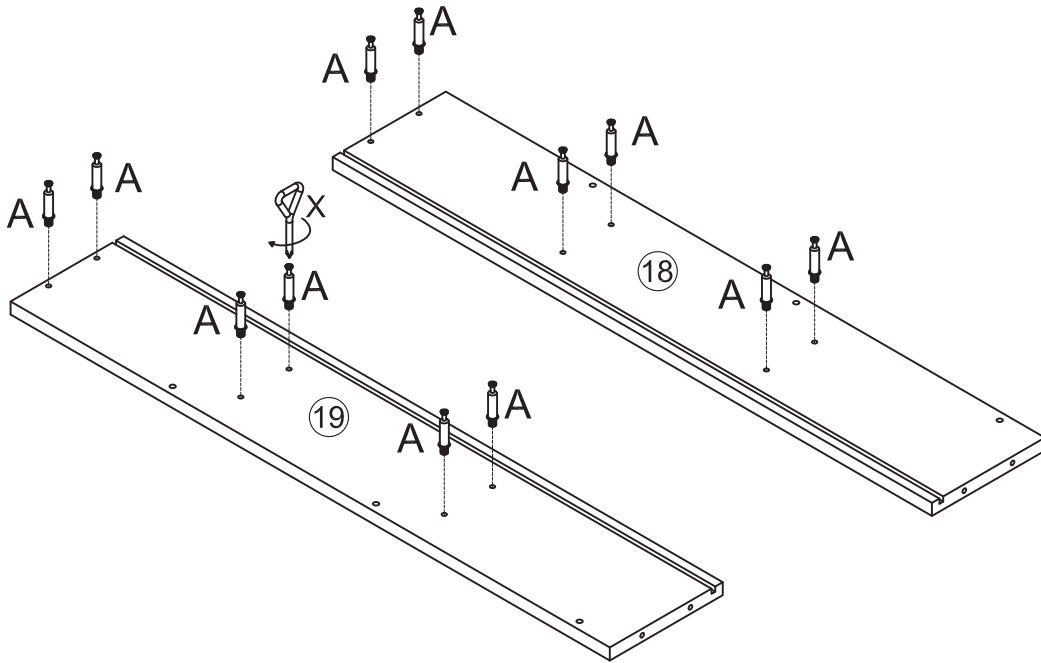

# Step 20

NOTE: All bolts must be fully tightened at this step.

Product support email: [jackye@hshfurniture.NET](mailto:jackye@hshfurniture.NET)

- 20.1** Align the Cam Bolts (A) on Left Side Panel ( 19 ) with the designated holes on one Top Shelf ( 20 ) and two Mid Shelves ( 21 ). Insert each two Cam Locks (B) into the corresponding holes on Top Shelf ( 20 ) and two Mid Shelves ( 21 ). make sure the arrow on Cam Lock (B) points to Cam Bolt ( A ), and then tightened by turning Screwdriver (X) clockwise. Ensure that the side with grooves on Top Shelf ( 20 ) should toward the side with groove on Left Side Panel ( 19 ) and face inwards, Align Panels ( 20/21 ) with the side without grooves on Left Side Panel ( 19 ) before tightened.

- 20.2** Insert three Metal Tubes ( 24 ) into the designated holes on Left Side Panel ( 19 ) as shown. Push each tube gently but firmly until fully seated. All bolts must be fully tightened at this step

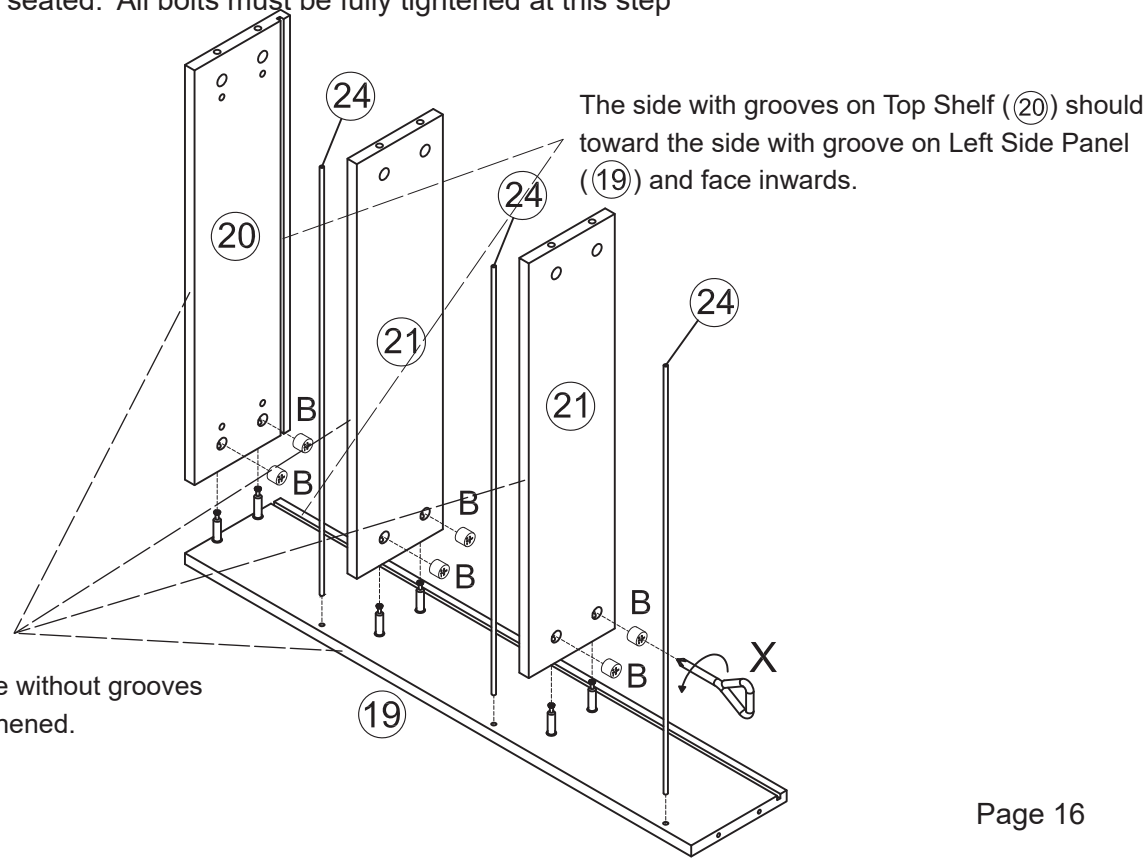

Align Panels ( 20/21 ) and the side without grooves on Left Side Panel ( 19 ) before tightened.

# Step 21

NOTE: All bolts must be fully tightened at this step.  
Product support email: [jackye@hshfurniture.NET](mailto:jackye@hshfurniture.NET)

- 21.1 Align the Cam Bolts (A) on the Right Side Panel (18) with the designated holes on one Top Shelf (20) and two Mid Shelves (21). Insert six Cam Locks (B) into the corresponding holes on Top Shelf (20) and two Mid Shelves (21). make sure the arrow on Cam Lock(B) points to Cam Bolt (A), and then tightened by turning Screwdriver (X) clockwise. Ensure the grooves on the three panels (18,19,20) are in the same plane.
- 21.2 Align the three Metal Tubes (24) with the three designated holes on Right Side Panel (18) and gently insert them into place.

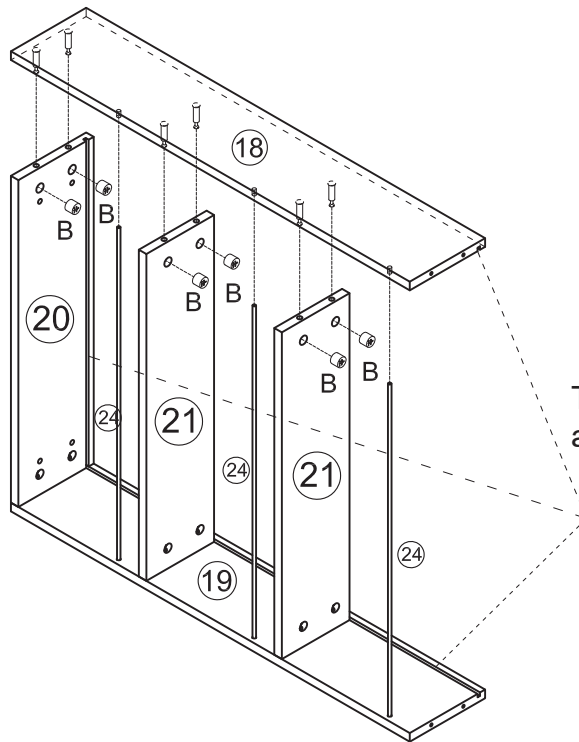

The grooves on the three panels (18, 19, 20) are in the same plane.

# Step 22

Product support email: [jackye@hshfurniture.NET](mailto:jackye@hshfurniture.NET)

- 22 Insert the Shelf Back Panel (23) vertically into the grooves of Side Panel (18, 19) and Top Shelf (20) as shown in the diagram. Ensure the panel is aligned properly and fully seated into the grooves, creating a secure fit.

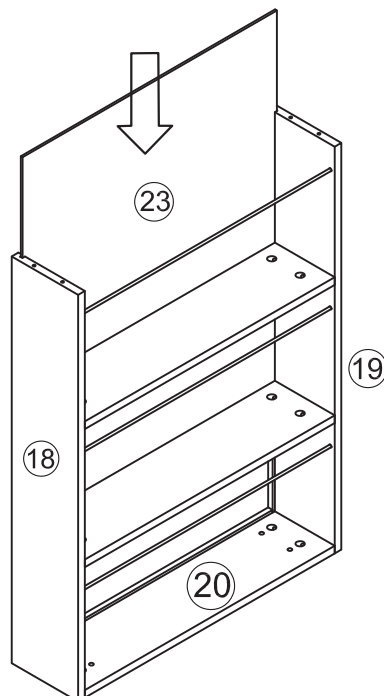

# Step 23

NOTE: All bolts must be fully tightened at this step.  
Product support email: [jackye@hshfurniture.NET](mailto:jackye@hshfurniture.NET)

- 23** Position Bottom Shelf (22) onto the assembled shelf structure. Connect and Fasten Bottom Shelf (22) to Side Panel (18 19) using four Long Bolts (D) by Allen Key (W). All bolts must be fully tightened at this step.

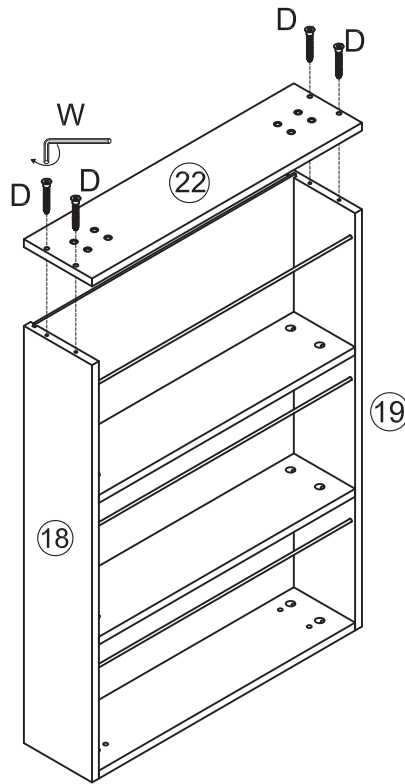

# Step 24

NOTE: All bolts must be fully tightened at this step.  
Product support email: [jackye@hshfurniture.NET](mailto:jackye@hshfurniture.NET)

- 24** Attach two Brake Casters (U) to the designated locations of Bottom Shelf (22) using eight Short Bolts (E) by Allen Key (W). All bolts must be fully tightened at this step.

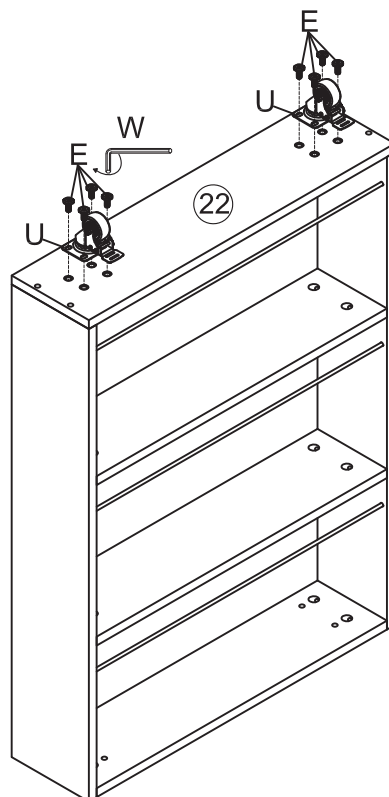

# Step 25

Product support email: [jackye@hshfurniture.NET](mailto:jackye@hshfurniture.NET)

- 25.1 Connect and fasten sixteen Panel Fasteners (P) to the Back Panel (9 10) with sixteen Fastener Screws (Q) by Screwdriver (X).
  - 25.2 Connect and fasten eight Panel Fasteners (P) to Shelf Back Panel (23) with eight Fastener Screws (Q) by Screwdriver (X).
- Note: All bolts must be fully tightened at this step.

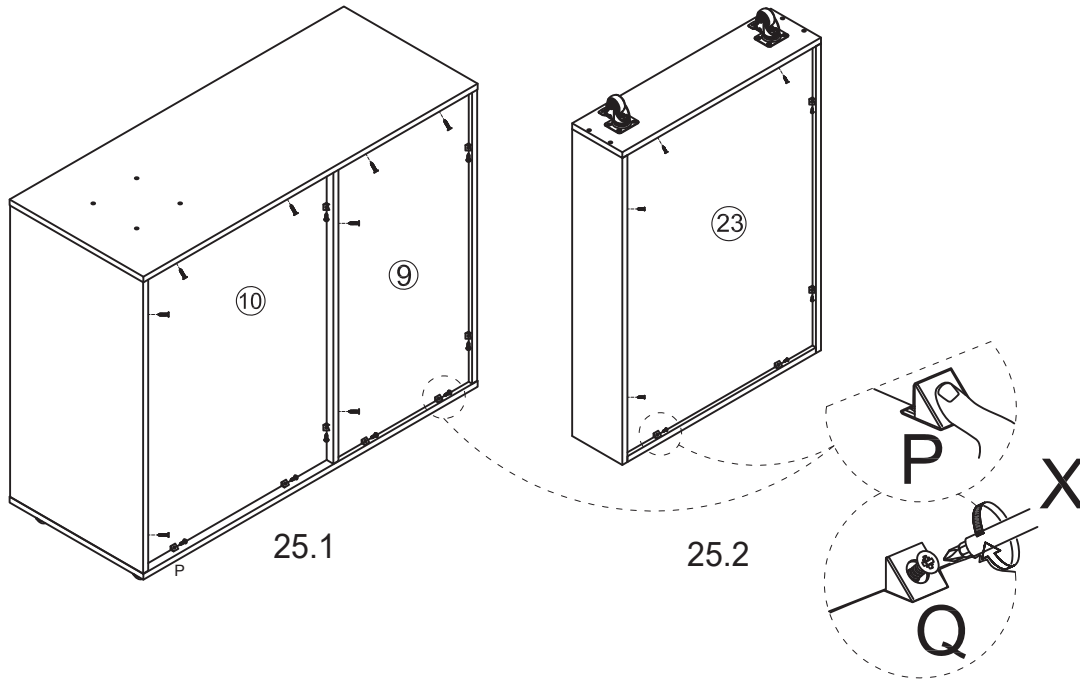

# Step 26

NOTE: All bolts must be fully tightened at this step.  
Product support email: [jackye@hshfurniture.NET](mailto:jackye@hshfurniture.NET)

- 26.1 Connect and fasten the pre-assembled Shelf part onto the Tabletop (1) using four Medium Bolts (F) by Allen Key (W).
- 26.2 Rotate one plate of the Swivel Base (26) about 45 degrees to expose the screw holes underneath, align and fasten Swivel Base (26) to Tabletop (1) using four Short Bolts (E) by Allen Key (W).

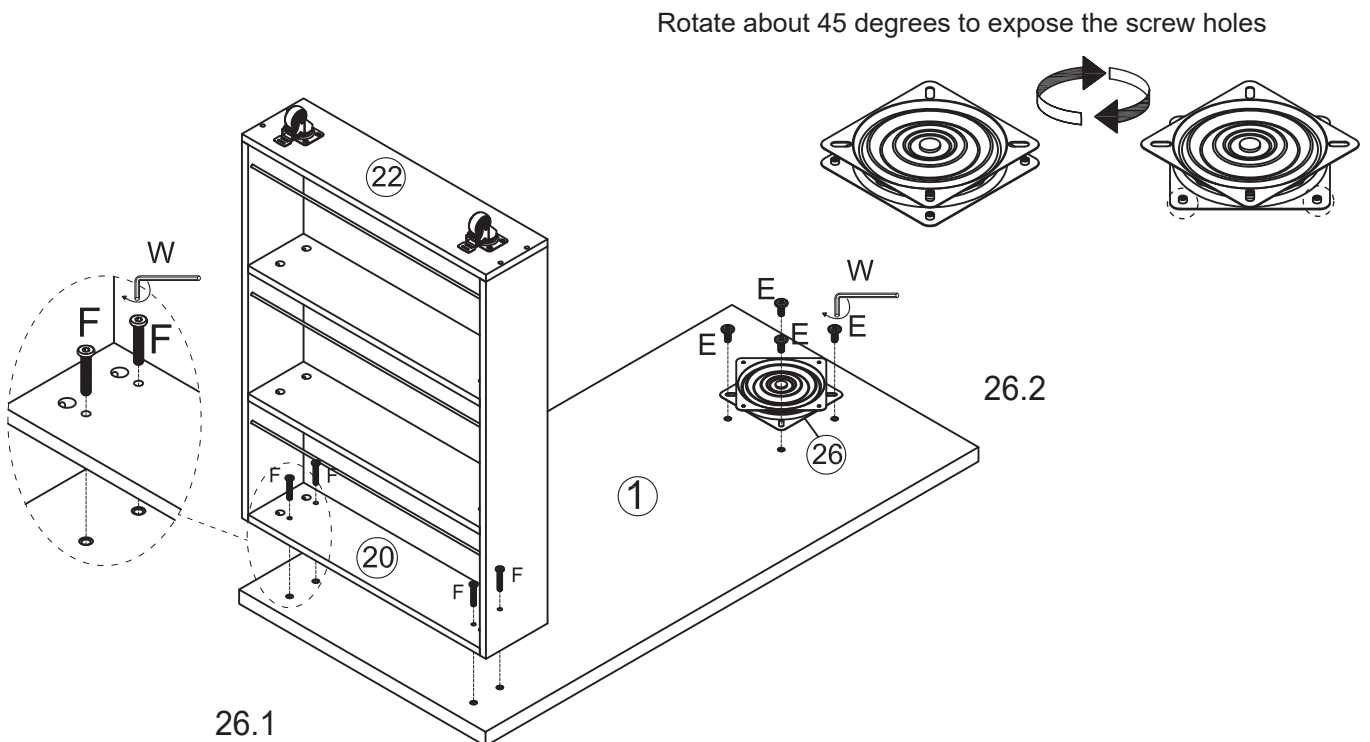

# Step 27

NOTE: If holes don't align, loosen all bolts and adjust the holes slightly. After all holes are aligned, tighten all bolts.

- 27.1 Align and attach Swivel Base (26) on Top Panel (2).
- 27.2 Connect and fasten Tabletop (1) to Top Panel (2) through Swivel Base (26) with four Medium Bolts (F) by Allen Key (W). After all holes are aligned, tighten all bolts or locks.

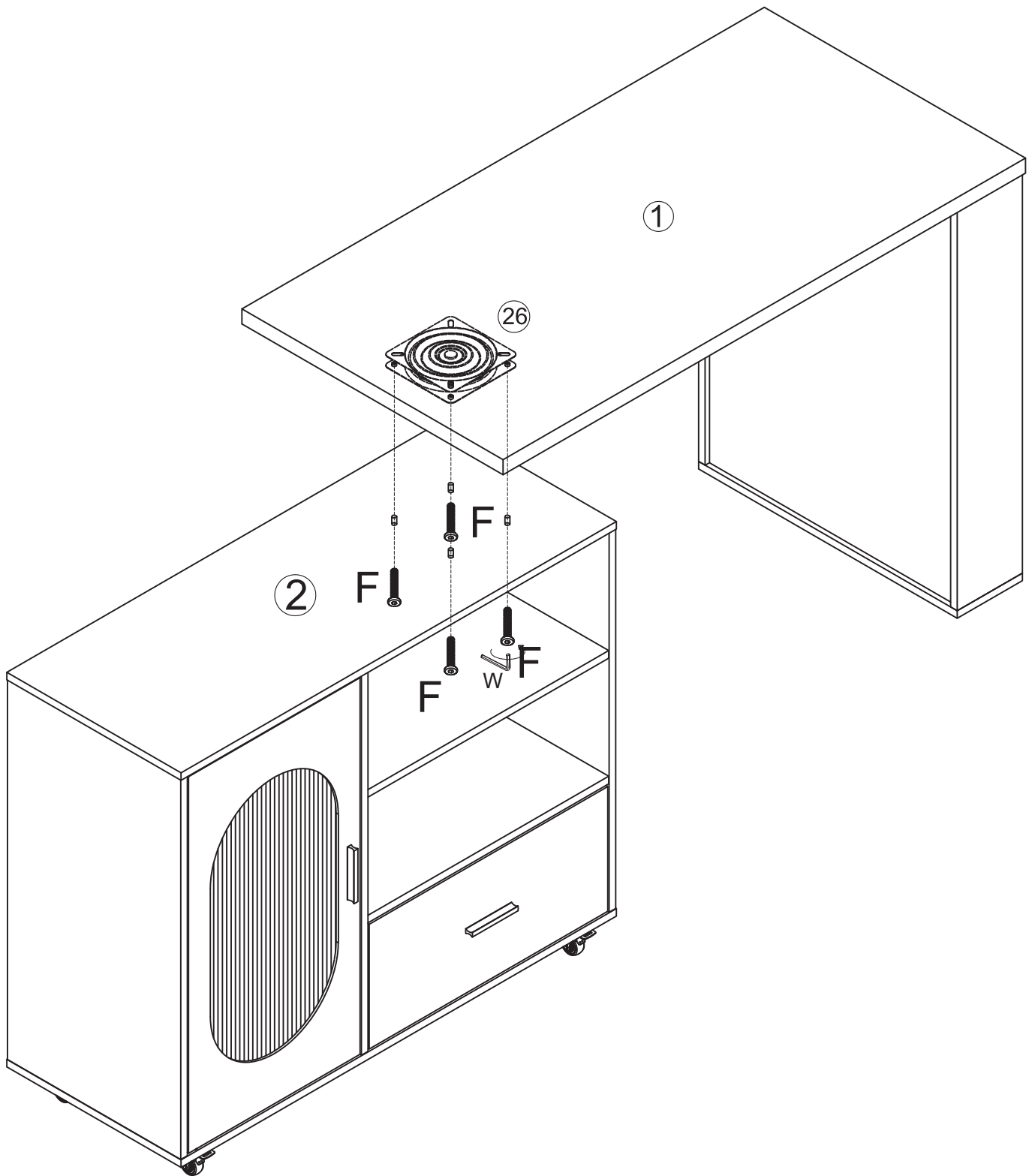

# Step 28

Product support email: [jackye@hshfurniture.NET](mailto:jackye@hshfurniture.NET)

28 Four assembly ways can be presented as below by rotating the Swivel Base (26).

