

4

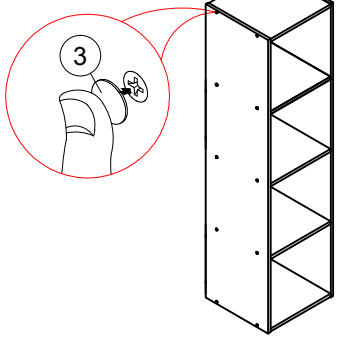

### Recommended Maximum Weight

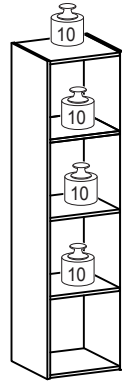

**WARNING:**

>This unit has been designed to support the maximum loads shown. Exceeding these load limits could cause sagging, instability, product collapse, and/or serious injury.

>DO NOT allow children to climb on unit.

>Put heavier items on lower shelves.

\*Unit in Pound(lbs)

PLEASE FOLLOW BELOW INSTRUCTION TO PREVENT PRODUCT TIP OVER.

HARDWARE PART LIST				QTY
x2				1 SET
BRACKET	LONG SCREW	SHORT SCREW	CABLE TIE	

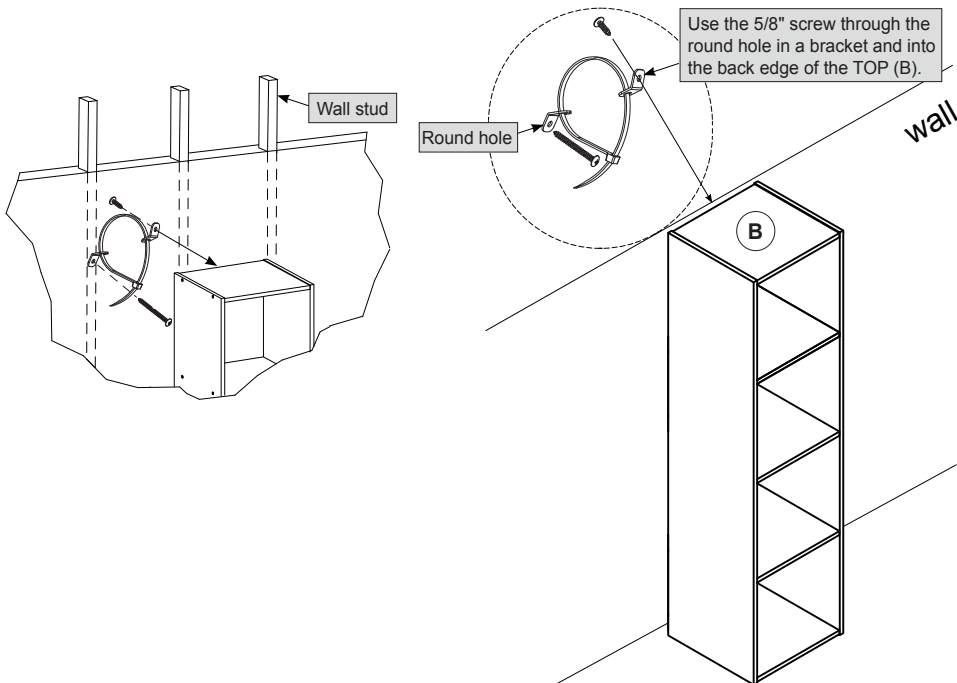

# Assembly Instruction

00:20

Approx. 20 minutes



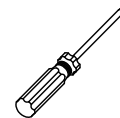

Recomm. 1 Person

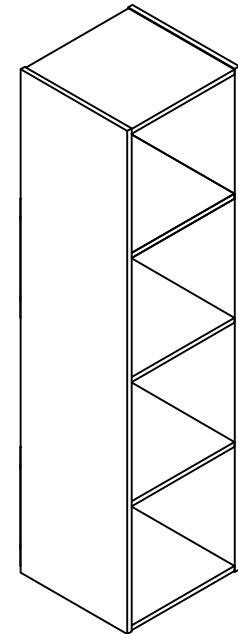

Tools Required



# HARDWARE & PARTS LIST

NO	HARDWARE LIST	QTY
1	SCREW 	20pcs
2	BACK PLUG 	16pcs
3	SCREW COVER CARD 	20pcs

NO	PARTS LIST	QTY
A	SIDE PANEL	2pcs
B	SHELF PANEL	5pcs
C	BACK PANEL	2pcs

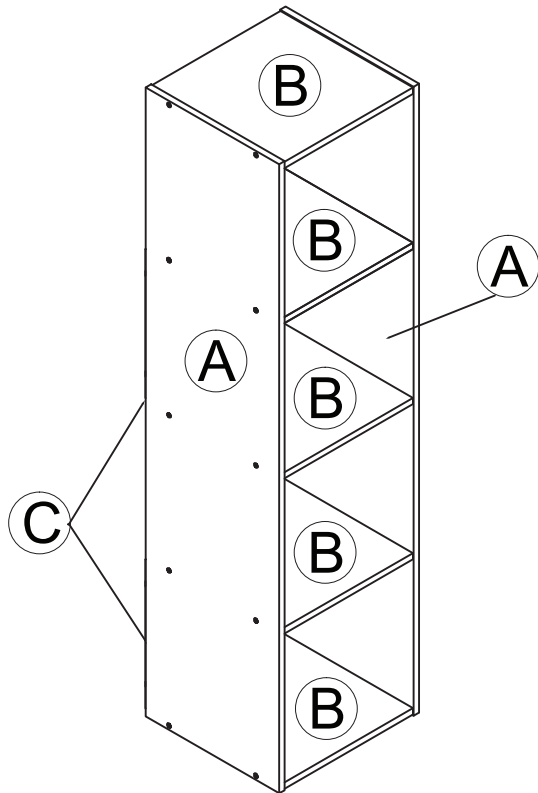

## USEFUL HINTS BEFORE YOU START:

1. Read each step carefully before starting.
2. It is important that each step is performed in correct order to avoid difficulties.
3. Identify, sort and count the parts before assembly.
4. Assemble your furniture on packaging cardboard to prevent scratch or damage.
5. Clean the product with mild cleanser using soft damped cloth. Do not use harsh or abrasive cleanser.
6. Using incompatible hardware might cause damage to product.

# ASSEMBLY INSTRUCTIONS

BEFORE YOU BEGIN, PLEASE READ ASSEMBLY INSTRUCTION CAREFULLY, FOLLOW THEM STEP BY STEP.

