

Pure & Easy



ASSEMBLY INSTRUCTIONS



WARNING

- If you need to use this greenhouse in severe weather conditions, please move valuable items indoors to avoid unnecessary financial loss.
- You must install the PC board greenhouse on a deck or level surface. If placing it on the ground, we recommend securing it with wooden strips under the frame and placing it in a pre-dug trench, then using ground stakes to further enhance stability.
- You must apply silicone sealant at the joints between the PC boards and the frame. Ensure that the clips are fastened in the correct direction onto the PC boards to prevent the boards from coming loose easily.
- Expansion screws and ground stakes are required to increase the overall stability of the product.

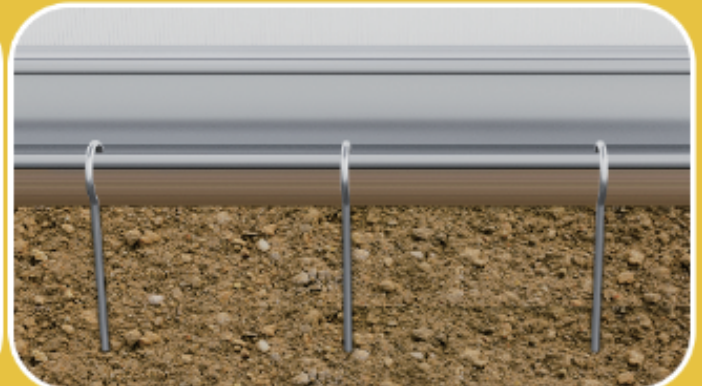
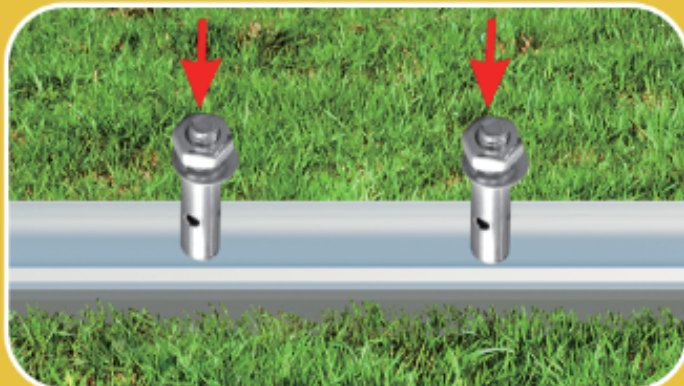
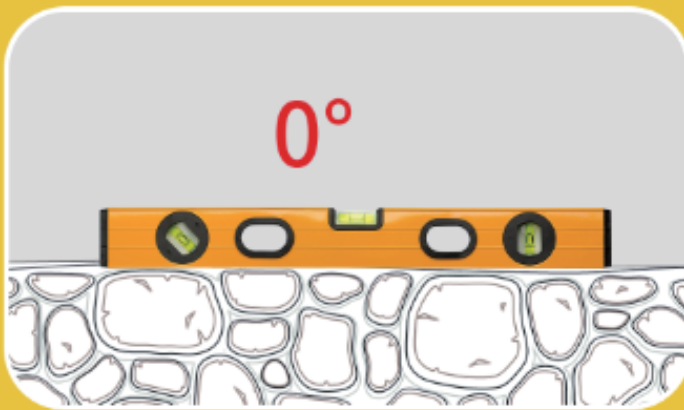

NOTICE

IMPORTANT, RETAIN FOR FUTURE REFERENCE: READ CAREFULLY
WICHTIG, FÜR SPÄTERE NACHSCHLAGE AUFBEWAHREN: SORGFÄLTIG LESEN
IMPORTANTE, GUARDAR PARA REFERENCIA FUTURA: LEER ATENTAMENTE
IMPORTANTE, CONSERVARE PER RIFERIMENTI FUTURI: LEGGERE ATTENTAMENTE
IMPORTANT, À CONSERVER POUR RÉFÉRENCE FUTURE : LIRE ATTENTIVEMENT

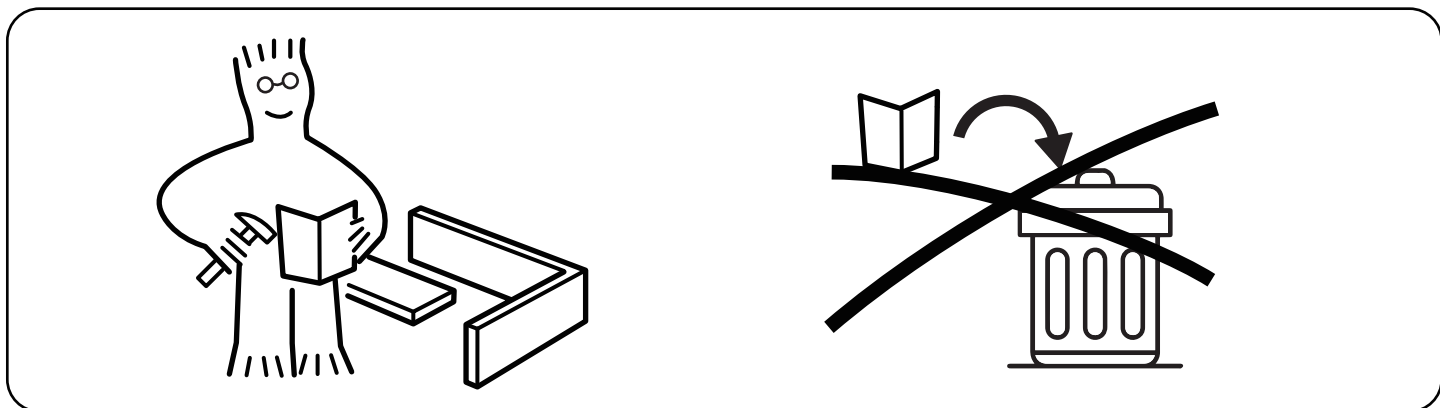

Assemble on a flat and solid surface. To avoid the unstable surface affecting the overall frame stability during installation.

Montieren Sie auf einer ebenen und festen Oberfläche. Um zu verhindern, dass eine unebene Oberfläche während der Montage die Gesamtrahmen-Stabilität beeinträchtigt.

Ensamblar en una superficie plana y sólida. Afin d'éviter que la surface inégale n'affecte la stabilité générale du cadre lors de l'installation.

Assemblare su una superficie piana e solida. Per evitare che una superficie irregolare influisca sulla stabilità complessiva della struttura durante l'installazione.

Assemble sur une surface plate et solide. Para evitar que la instalación en una superficie irregular afecte la estabilidad general del marco.

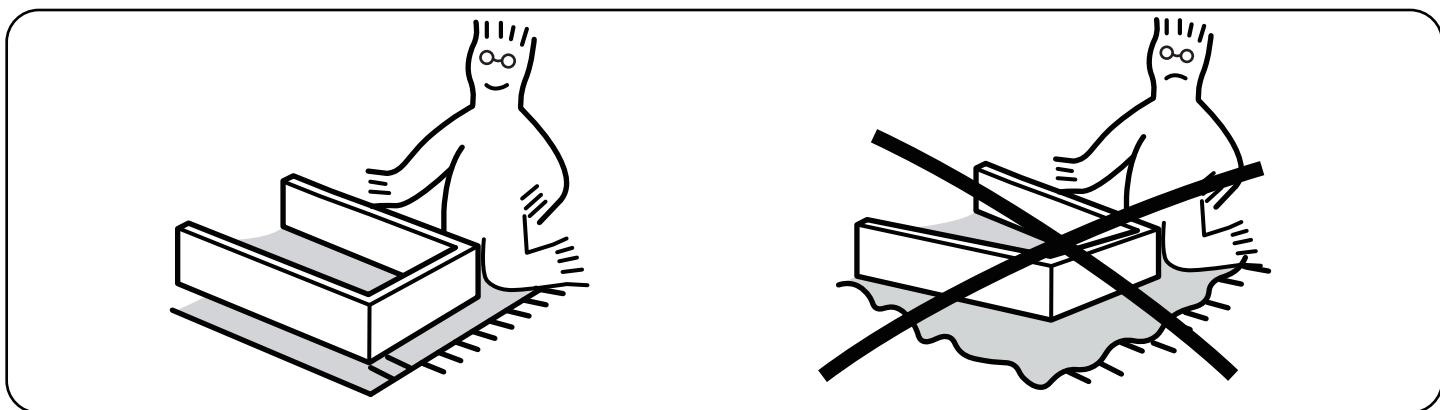

Professional installation is highly recommended.
Eine professionelle Installation wird dringend empfohlen.
Une installation professionnelle est fortement recommandée.
Si raccomanda vivamente l'installazione professionale.
Se recomienda altamente la instalación profesional.



Periodically Check That All Components Are Tightly Secured.
Überprüfen Sie Regelmäßig, Dass Alle Komponenten Fest Gesichert Sind.
Vérifiez Périodiquement Que Tous Les Composants Sont Bien Fixés.
Controllare Periodicamente Che Tutti I Componenti Siano Ben Fissati.
Verifique Periódicamente Que Todos Los Componentes Estén Bien Asegurados.

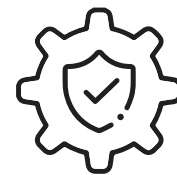

It is recommended that multiple people assemble this product.
Es wird empfohlen, dass mehrere Personen dieses Produkt zusammenbauen.
Il est recommandé que plusieurs personnes assemblent ce produit.
Si raccomanda che più persone assemblino questo prodotto.
Se recomienda que varias personas ensamblen este producto.

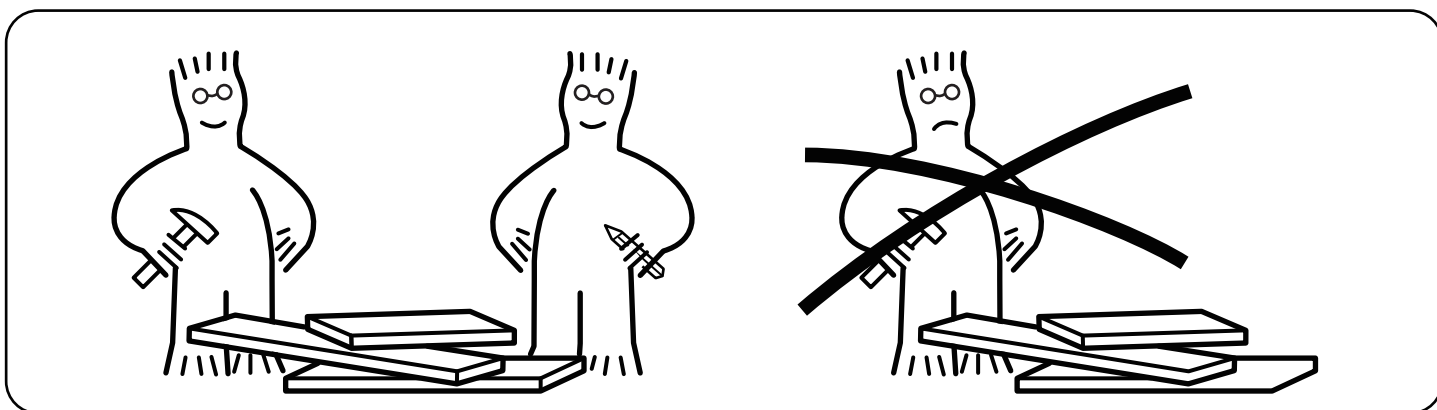

Please contact us if parts of your furniture are missing.
Bitte kontaktieren Sie uns, wenn Teile Ihrer Möbel fehlen.
Por favor contáctenos si faltan piezas de sus muebles.
Si prega di contattarci se mancano parti dei vostri mobili.
Veuillez nous contacter si des pièces de vos meubles manquent.



Please have the following auxiliary tools ready:

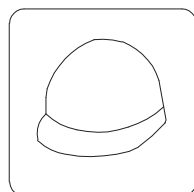
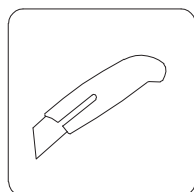
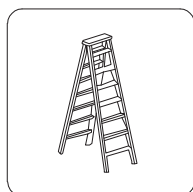
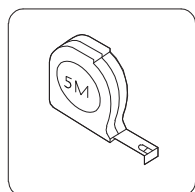
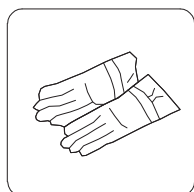
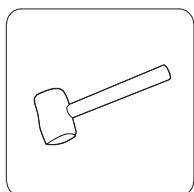
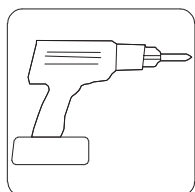

Notes:

Please read this instruction carefully and keep it for later reference. Each assembly step will be detailed explained below. Refer to the enlarged illustration to determine the precise arrangement of the components.

Attention:

A foundation is not included in the delivery.
Adequate fastening must be ensured by the customer!
A suitable foundation is available as an optional accessory.
Instructions for self-construction can also be found on page 7.









Please wear gloves during assembly.
The corners and edges of the components may be sharp and hard.
Proceed with caution to avoid injuries.
Take your time for the assembly and plan sufficient breaks.
The assembly will take some time and requires a methodical approach.
Store the greenhouse in a dry and frost-free place when not in use.
The twin-wall polycarbonate panels should not be pressed or bent.
Keep all components away from sources of fire and sparks!

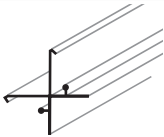
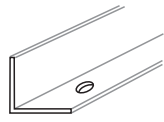
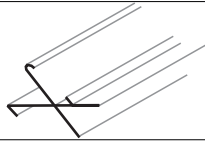
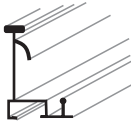
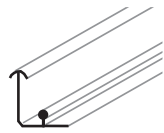
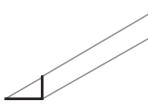
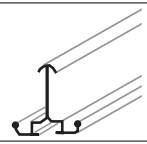
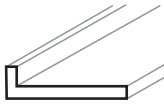
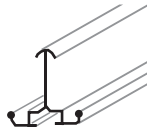
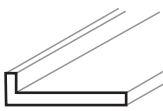
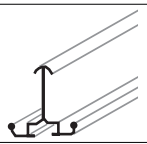
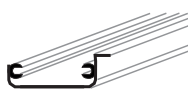
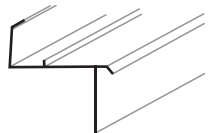
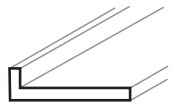
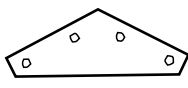
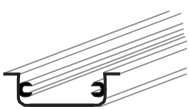
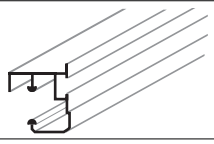
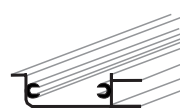
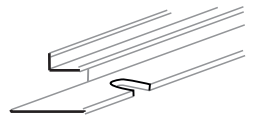
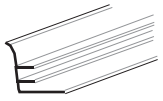
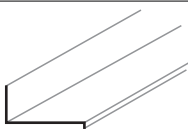
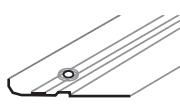
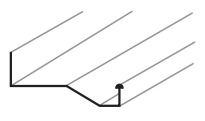
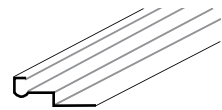
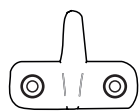
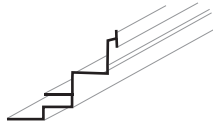

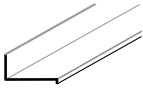
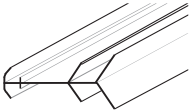
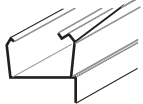
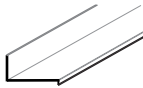
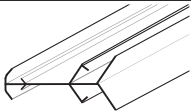
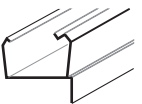
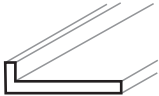
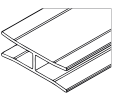

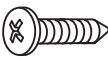

Before assembly:

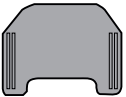
Find a solid and level surface as the base before starting the assembly.
Read the assembly instructions carefully before assembly and follow each step precisely.
Check all supplied parts for completeness and integrity.
Gather all greenhouse parts and the required tools (not included in the delivery) before assembly.
Only set up the greenhouse in dry weather.
Never assemble in strong winds or poor weather conditions!
The assembly requires multiple persons.

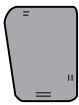
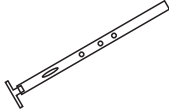
PARTS

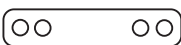
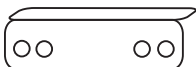
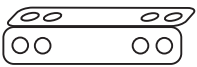
| Item NO. | Quantity | Part | Size mm | Item NO. | Quantity | Part | Size mm |
|----------|----------|---|---------|----------|----------|---|---------|
| 1 | 4 |  | 1214 | 19 | 1 |  | 380 |
| 2 | 1 |  | 1132 | 20 | 2 |  | 1586 |
| 3 | 1 | | | | | | |
| 4 | 1 | | | | | | |
| 5 | 1 | | | | | | |
| 6 | 1 |  | 1639 | 21a | 1 |  | 1235 |
| 7 | 1 | | | | | | |
| 8 | 1 |  | 1665 | 22 | 4 |  | 1302 |
| 9 | 1 | | | | | | |
| 10 | 8 |  | 1214 | 23 | 2 |  | 595 |
| 11 | 8 |  | 1115 | 24 | 1 |  | 616 |
| 12 | 1 |  | 618 | 25 | 2 |  | 1292 |
| 13 | 4 |  | | 26 | 2 |  | 616 |
| 14 | 1 |  | 1255 | 27a | 1 |  | 616 |
| 15 | 2 |  | 635 | 30 | 4 |  | 522 |
| 16a | 1 |  | 1310 | 31 | 1 |  | 609 |
| 17a | 1 |  | 1310 | 32 | 2 |  | 595 |
| 18 | 4 |  | | 33 | 2 |  | 598 |

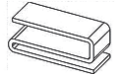
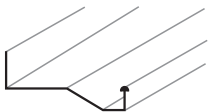
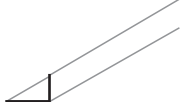





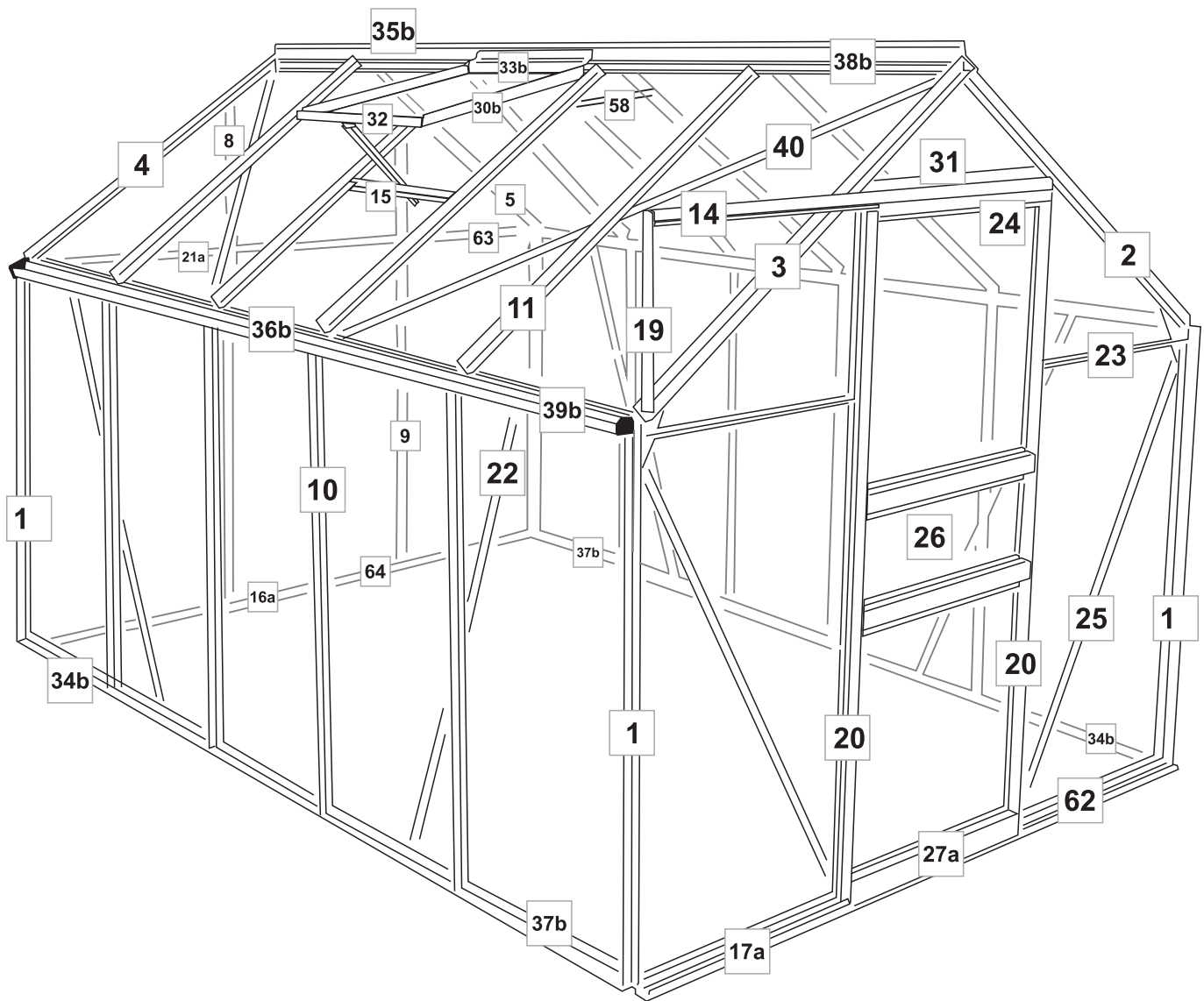

| Item NO. | Quantity | Part | Size mm |
|----------|----------|---|---------|
| 34b | 2 |  | 1555 |
| 35b | 1 |  | 1525 |
| 36b | 2 |  | 1532 |
| 37b | 2 |  | 1555 |
| 38b | 1 |  | 1525 |
| 39b | 2 |  | 1532 |
| 40 | 4 |  | 1640 |
| 41 | 5 |  | 605 |
| 42 | 1 |  | M6 |
| 43 | 154 |  | M6x10 |
| 44 | 16 |  | M4.5x19 |
| 45 | 12 |  | M4x7.5 |
| 46 | 232 |  | |
| 47 | 8 |  | |
| 48 | 4 |  | |

| Item NO. | Quantity | Part | Size mm |
|----------|----------|---|---------|
| 49 | 1 |  | |
| 50 | 1 |  | |
| 51 | 2 |  | |
| 52 | 155 |  | M6 |
| 53 | 1 |  | M6 x 30 |
| 54 | 3 |  | |
| 55 | 2 |  | |
| 56 | 1 |  | |
| 57 | 1 |  | |
| 58 | 2 |  | 400 |
| 59 | 78 |  | |
| 62 | 1 |  | 580 |
| 63 | 1 |  | 625 |
| 64 | 1 |  | 580 |

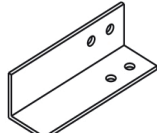
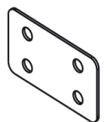
EXPLODED VIEW



ASSEMBLY

- 1  2PCS
- 2  4PCS
- 3  4PCS
- 4  4PCS
- 5  14PCS
- 6  32PCS
- 7  32PCS
- 8  12PCS
- 9  2PCS

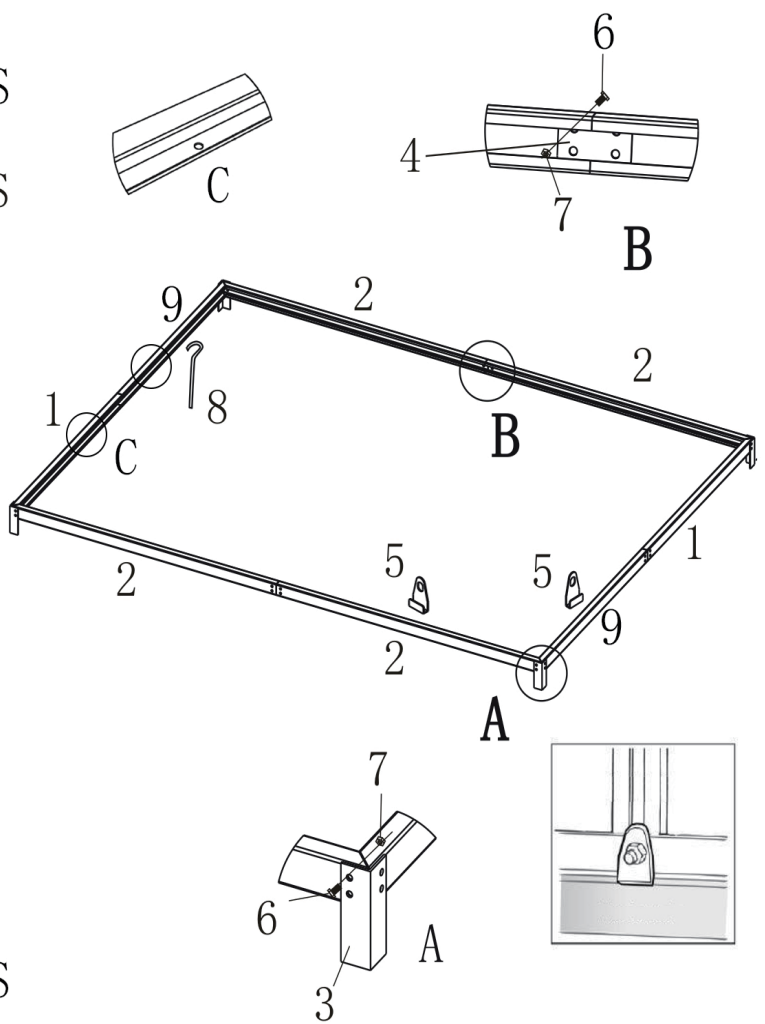

Foundation, Self-Construction Guidelines, and Fastening

Adequate fastening must be ensured by the customer!

Information: A foundation is not included in the delivery.

A suitable foundation is available as an optional accessory.

The following details serve as an example and help for building a foundation using stone or concrete with a wooden frame.

The foundation layout must be rectangular and level.

Please consider the following dimensions:

A Concrete/stone foundation:

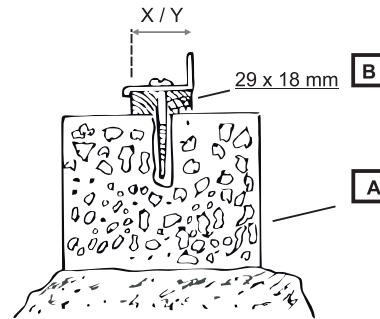
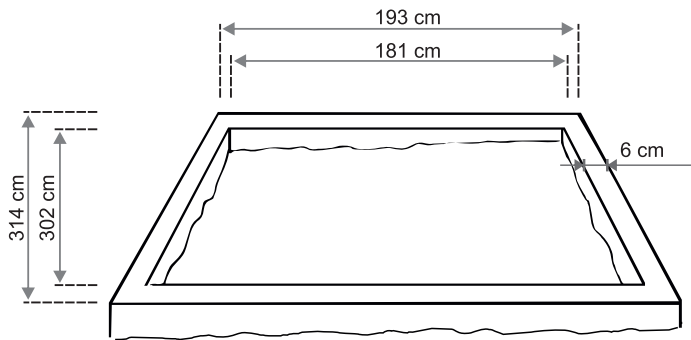

B Wooden frame

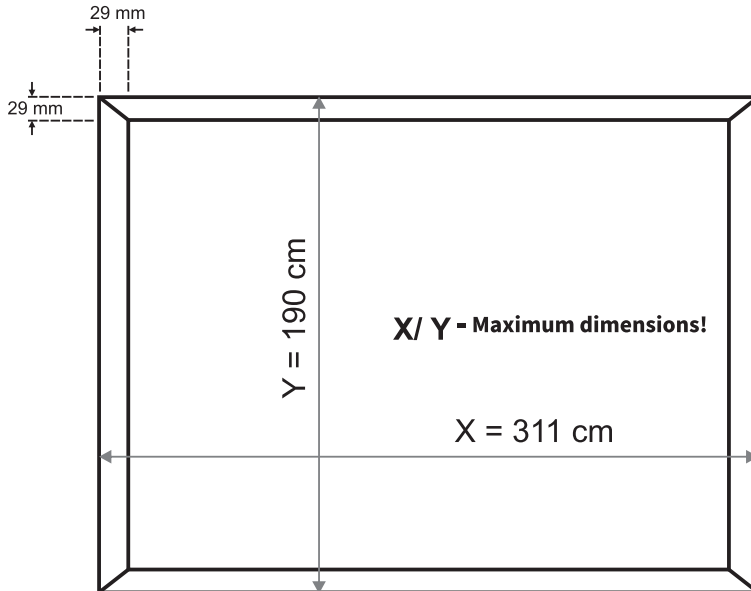

The front side of the greenhouse (part #17) should not rest completely, see page 22, Fig. [C].

Alternatively: attachment to the optionally available foundation.

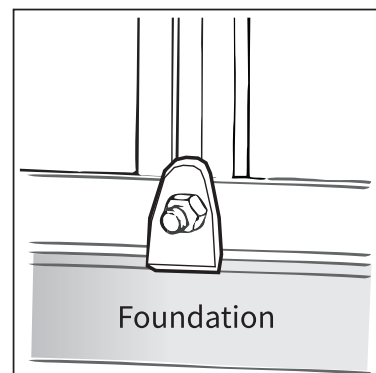
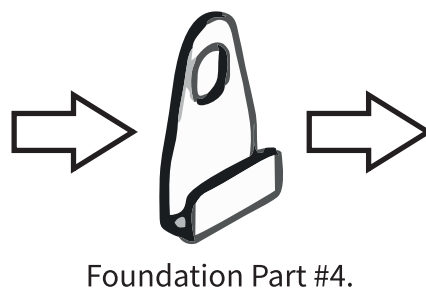
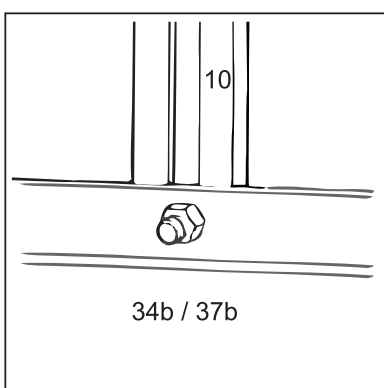

Door installation

Assemble the door as shown:

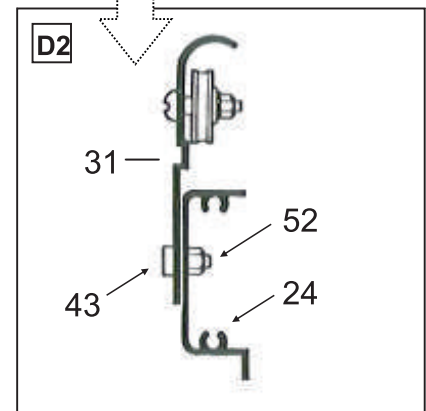
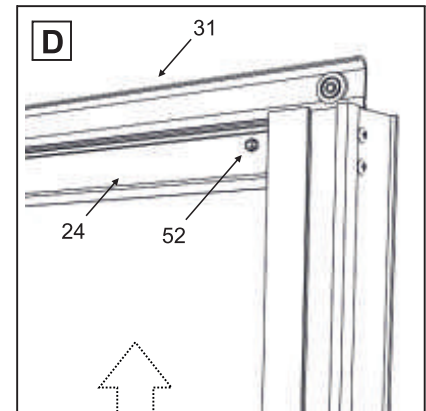
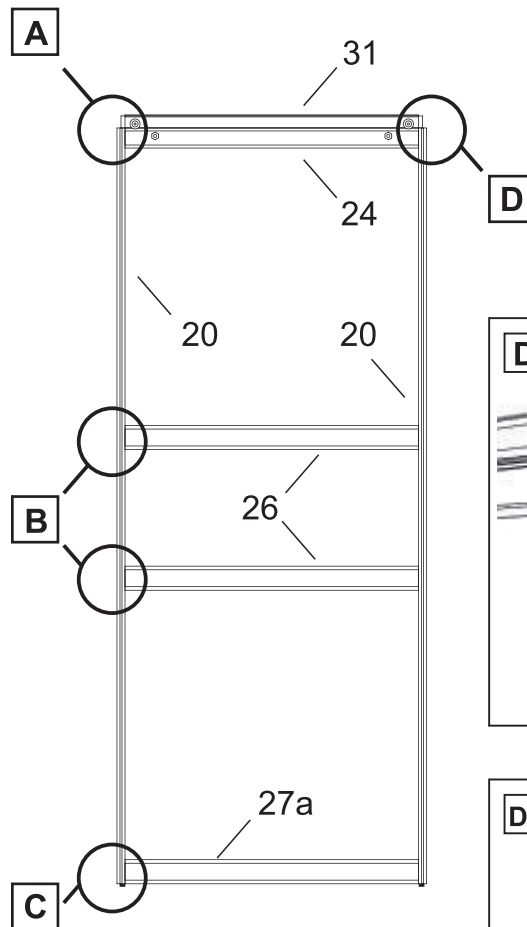
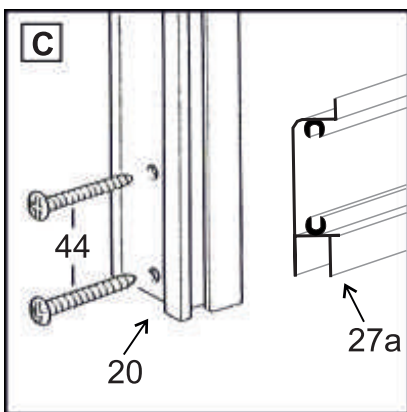
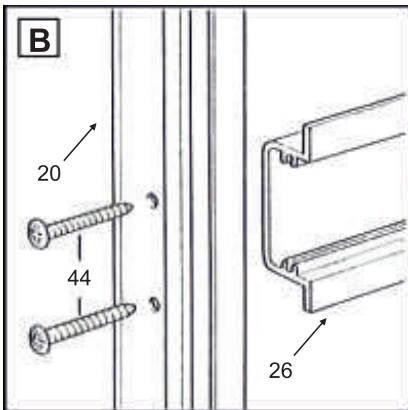
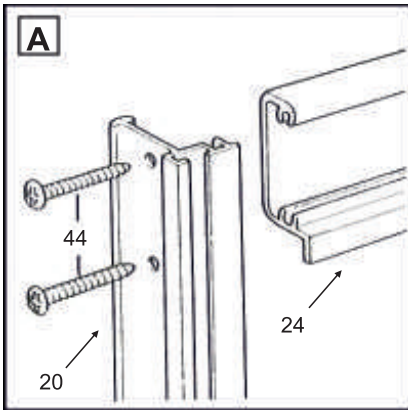
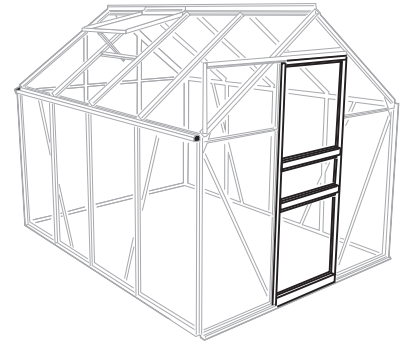

Note: Figures A to D are interior views.

Lay out the corresponding profiles on a flat surface. Assemble the left side, following the instructions provided in figures [A], [B], and [C]. Then, screw the right side (#20) accordingly.

Next, attach the running rail (#31) to profile #24, as shown in figure [D].

Door panel installation

Place the door on a flat surface.
Insert the 3 panels (No.7 and 2x No.9) as shown.
Secure them on the sides with clips.

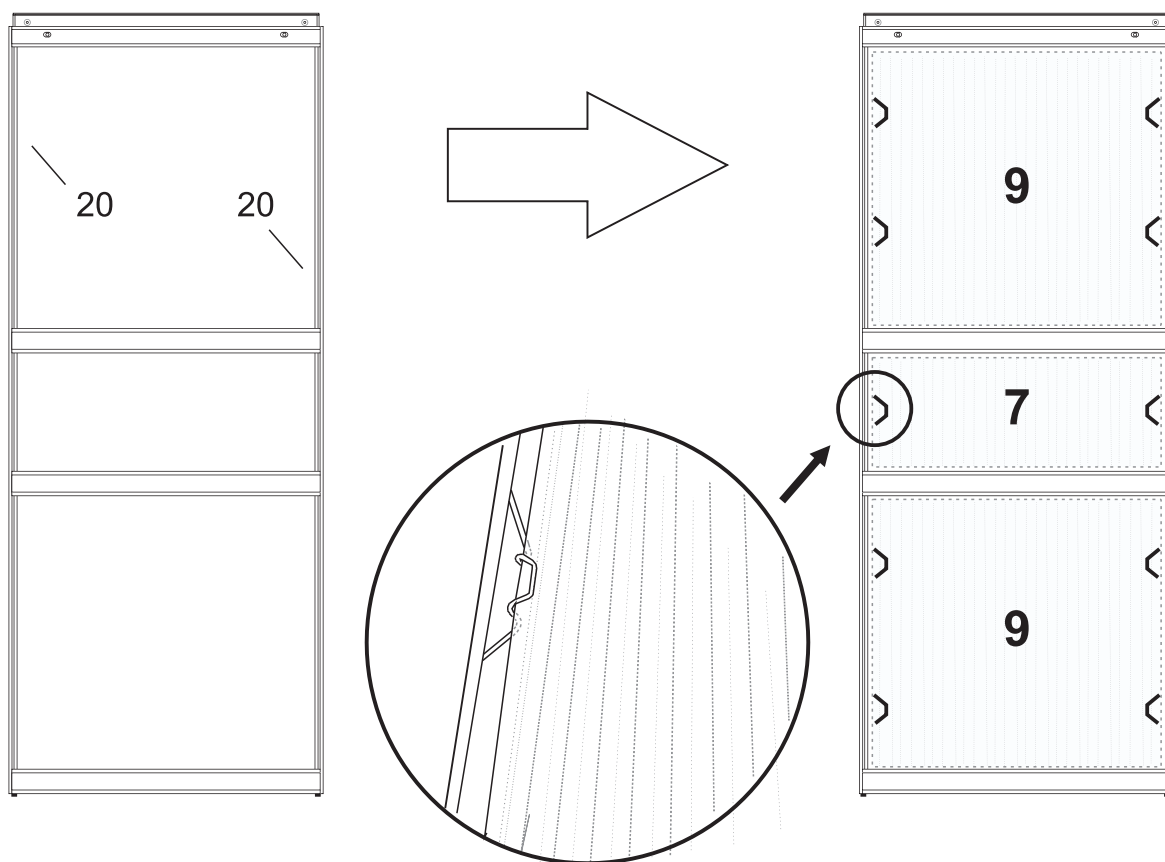

Note: Figures are exterior views.

Please pay attention to the instructions regarding the correct orientation of the panels for UV protection (see also page 20).



Side profile installation

Connect the side profiles together.
Secure them using the mounting plates (54/55/56),
hammerhead screws (#43), and M6 nuts (#52).

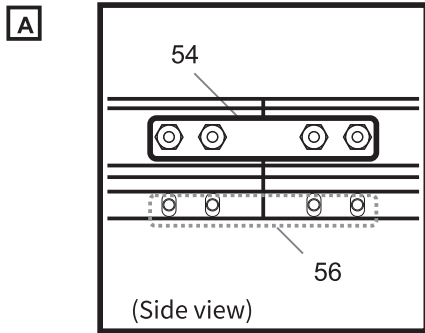
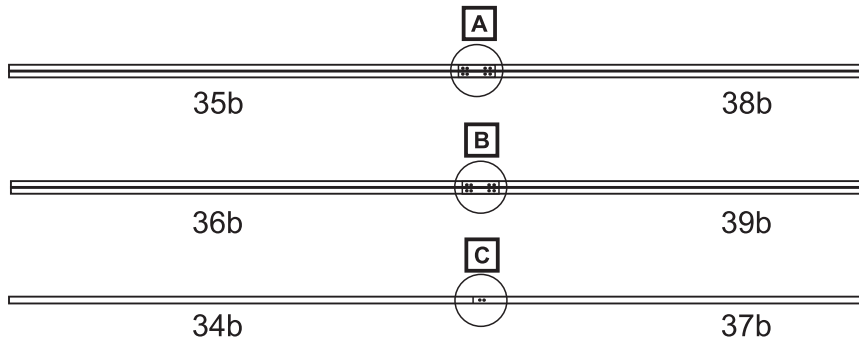
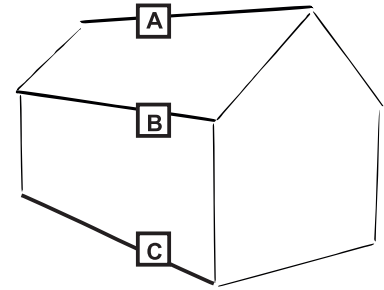

35b + 38b

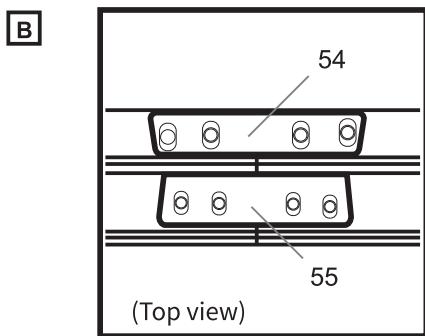
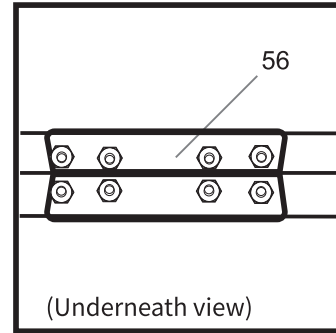

36b + 39b

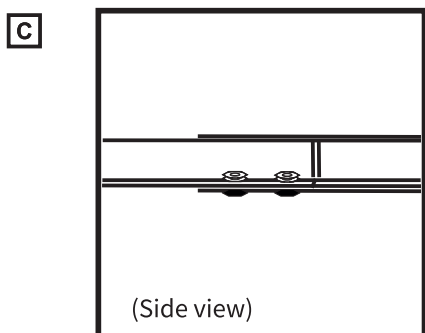
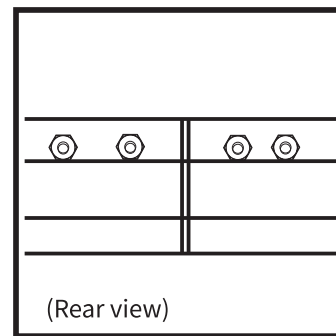

34b + 37b

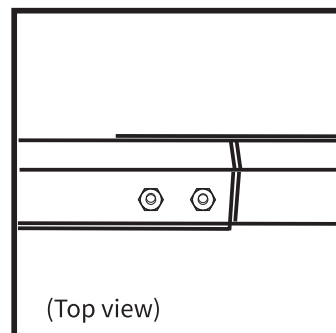

Installation of side walls (interior view).

Lay the cross profiles onto the longitudinal profiles as shown and screw everything together.

(!) Pay attention to the particularity regarding part #10 - if necessary, insert additional screws!

Proceed in the same way with the other side.

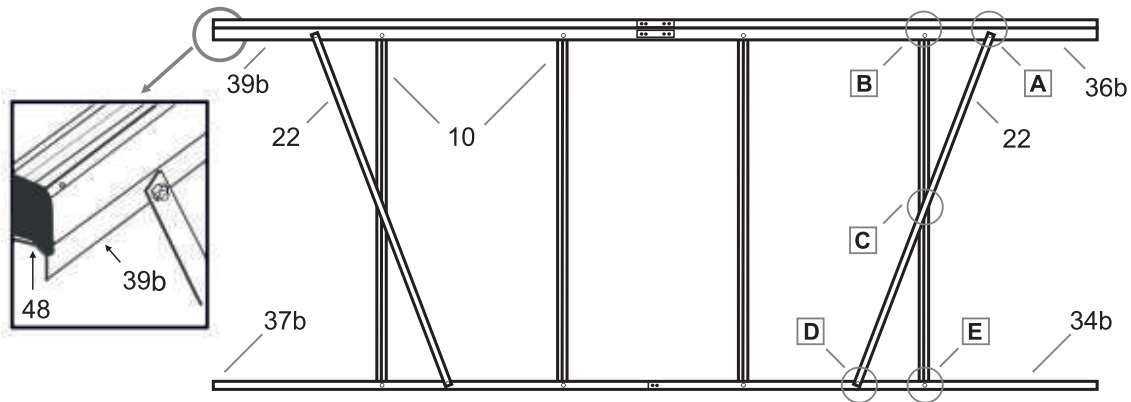
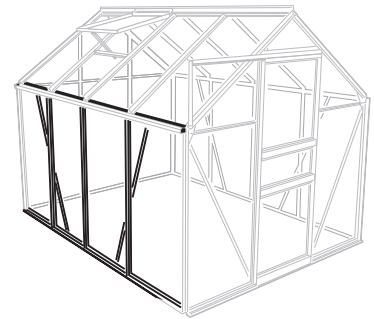

For the installation of part #22: insert one screw #43 on the 1st, 3rd, and last profile #10. (Fig. [B] and [C])



Screw head inside the profile!

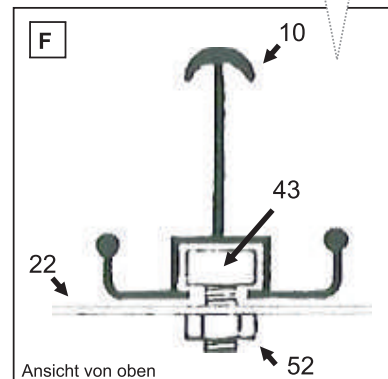
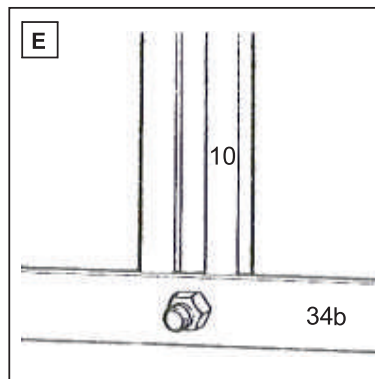
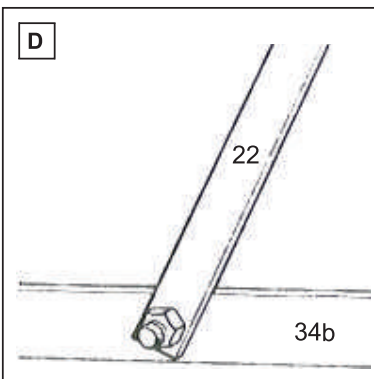
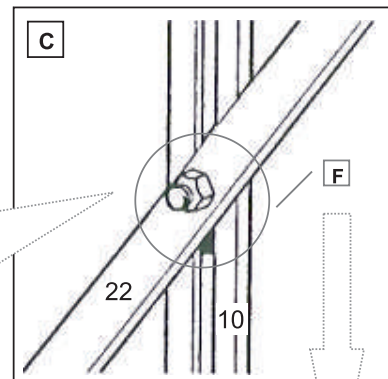
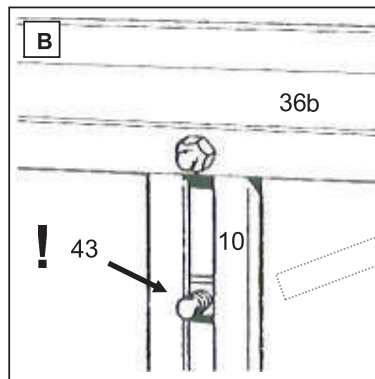
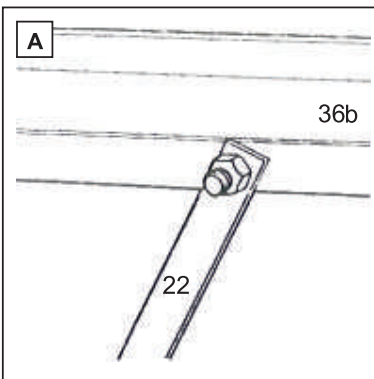

Note: Figures A - E are interior views.

Gable side, without door (interior view)

Lay out the necessary profiles on a flat surface (arranged as shown).

Screw the profiles together as depicted.

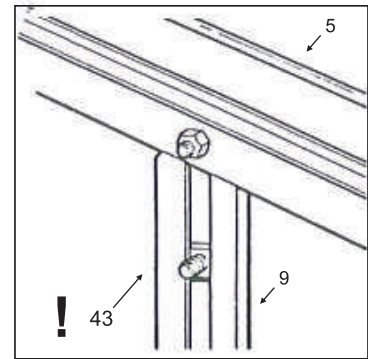
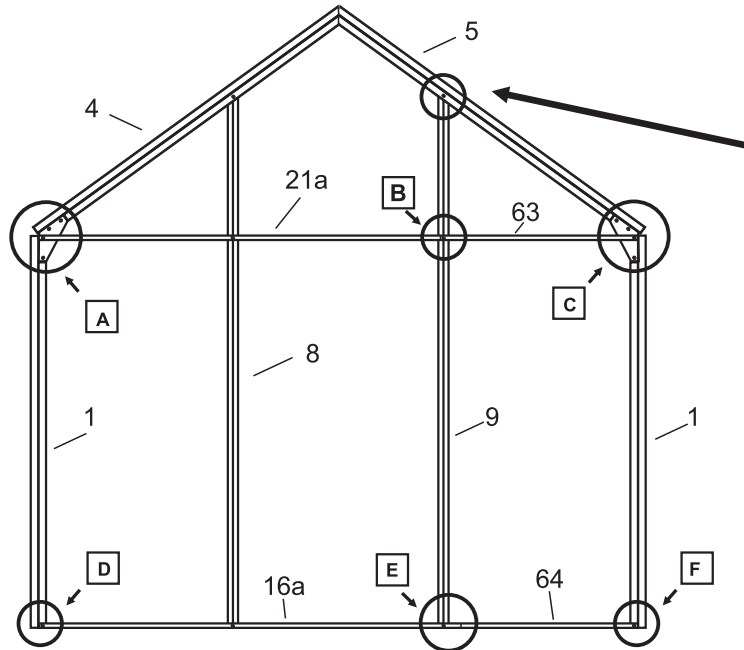
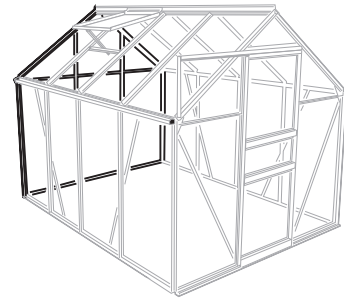

Assemble part #21a with part #63:
 ! Insert one screw #43 into profile #8 and one screw #43 into profile #9 (Fig. [B]).

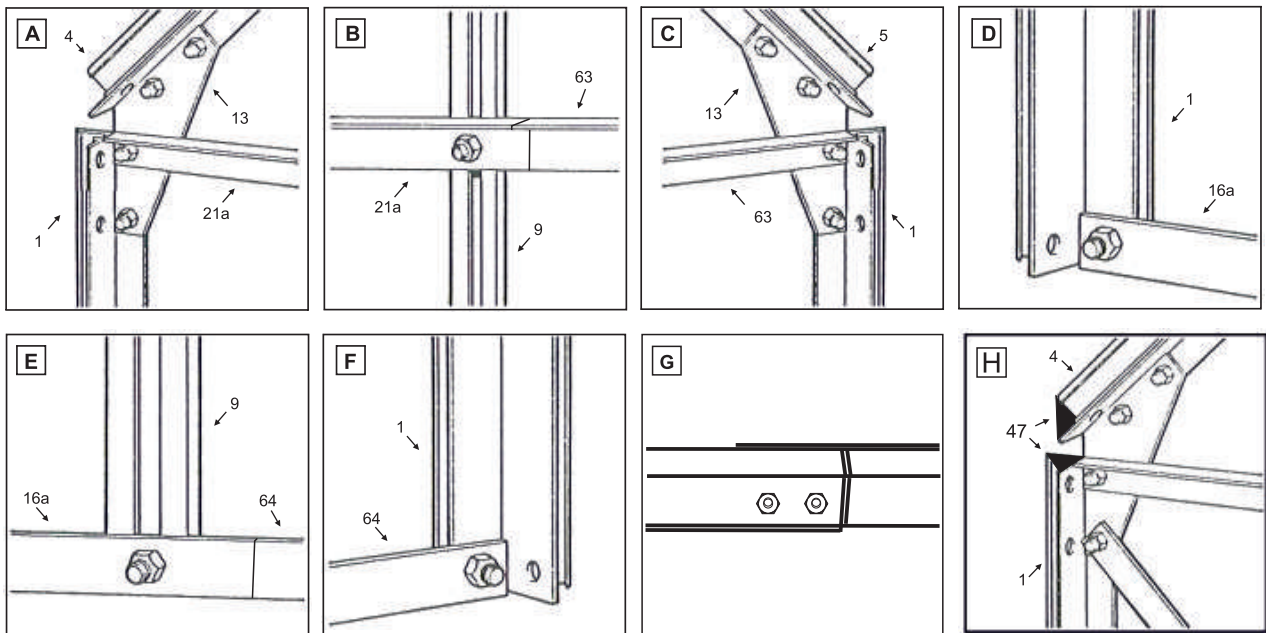

i Hinweis: Abbildungen sind Innenansichten.

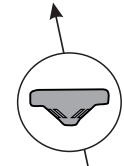

(*) Note regarding [A]:
 The cover #47 is attached to part #1 and part #4, and then on the other side to part #1 and part #5.

Roof window - Assembly

Assemble the profiles as shown in the illustration.

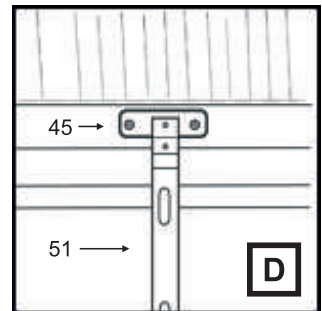
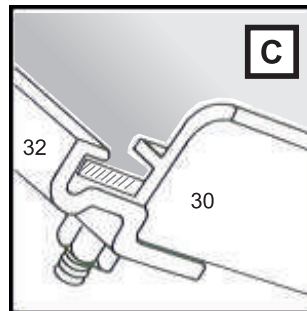
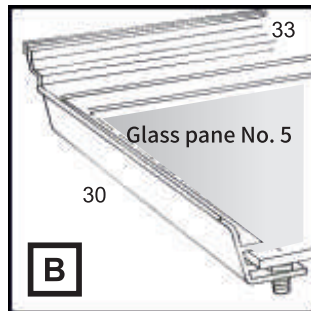
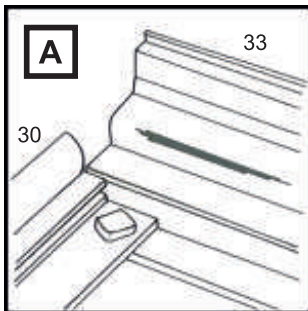
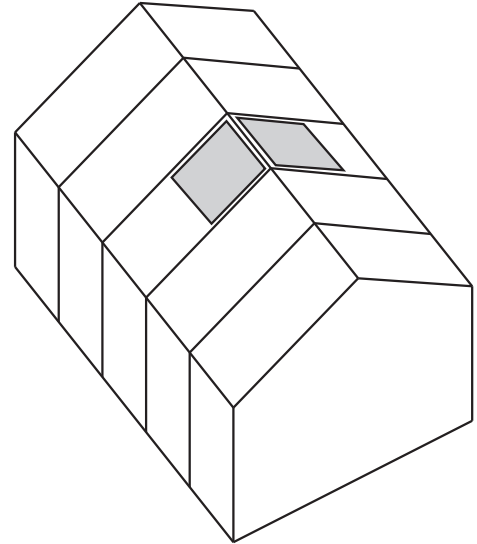
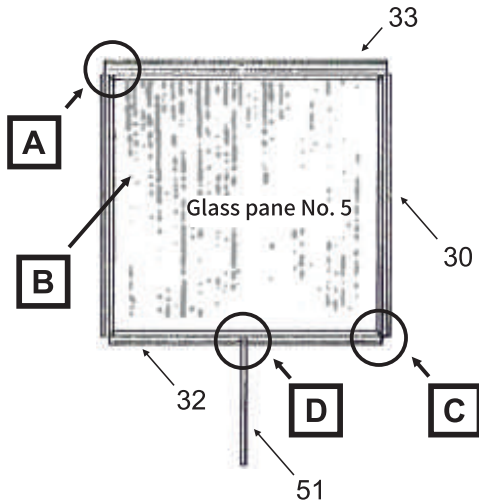

Note: Tighten nuts only during final assembly. !

[A]: Screw part #33 together with the two side parts (#30).

[B]: Now, insert glass pane No. 5.

Pay attention to the instructions (film) for the correct alignment of the panel - for UV protection (see also page 20).



[C]: Next, attach the lower profile (#32).

Check if the window frame is square, and then tighten all the nuts securely.

[D]: Now, secure part #51 (support rod) to the window frame using screws #45.

Gable side with door - Interior view

Lay out the necessary profiles (arranged as shown) on a flat surface.
Assemble the profiles according to the detail drawings [B] - [F].

(* Note for [A]: Before assembly, attach cover #50 to the end of part #14 at the connection point #14 and #19.

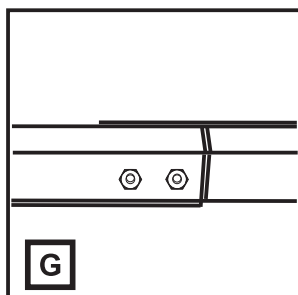
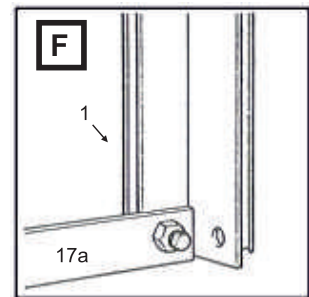
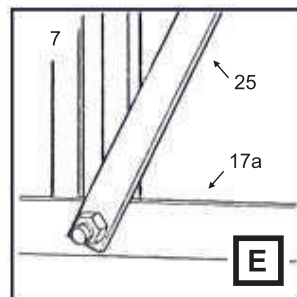
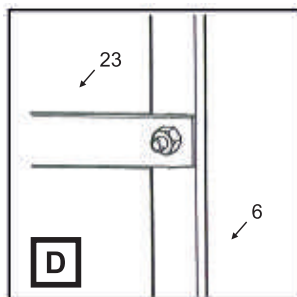
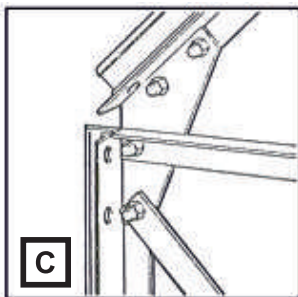
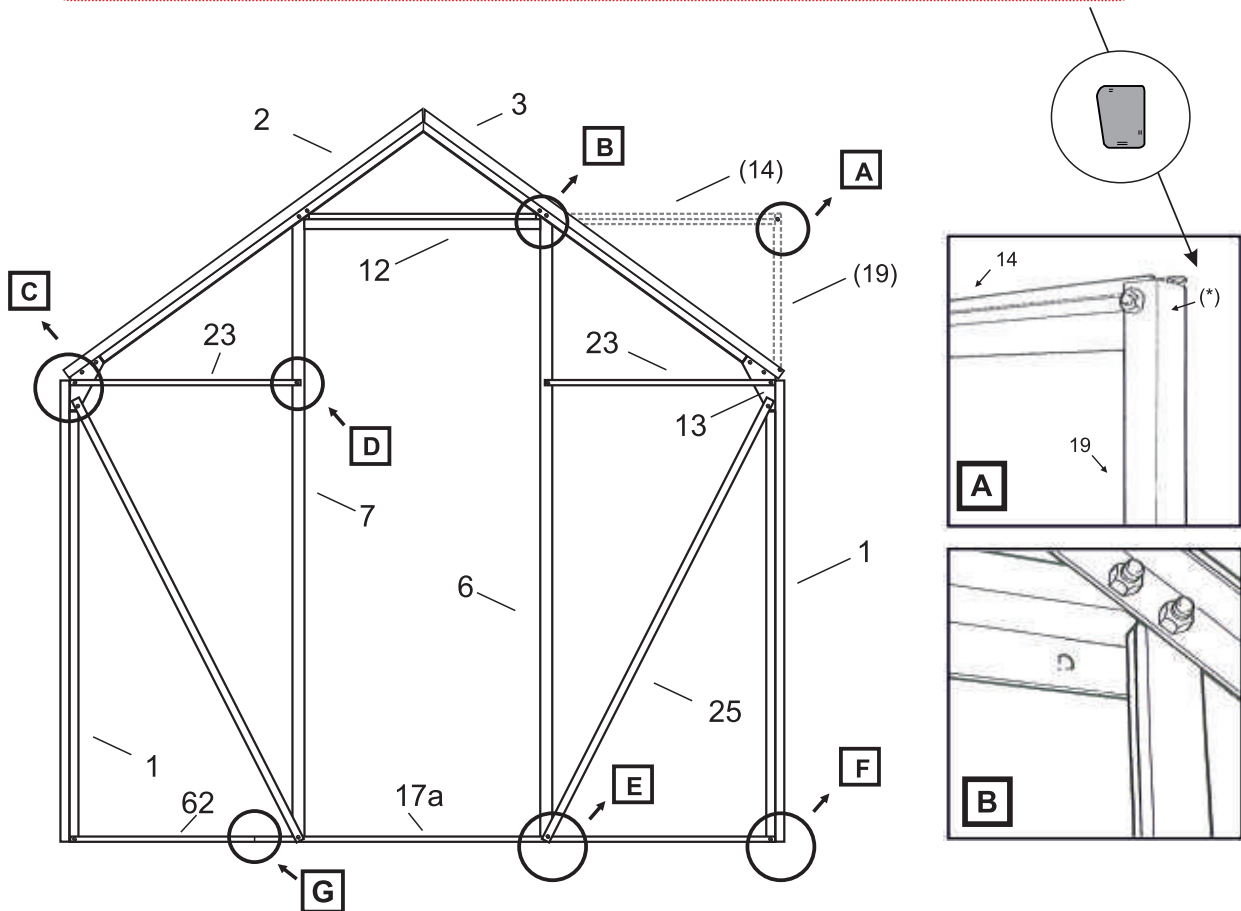

Arrangement of screws:

! Screw head on the outside,
nut on the inside.



Note: Illustrations are interior views.

Attach the side with the door - exterior view

Attach parts #14 and #19 as shown.
(see also Fig. [A] on page 14)

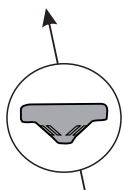
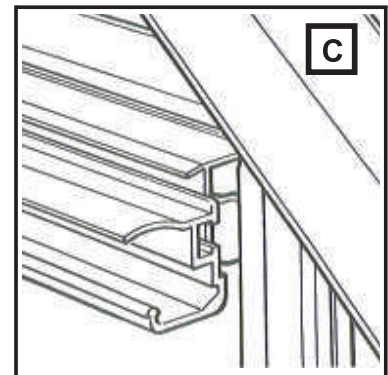
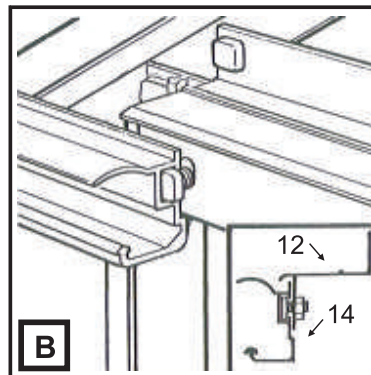
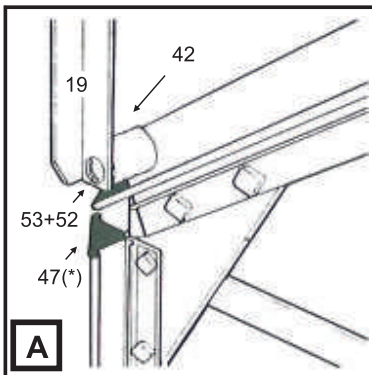
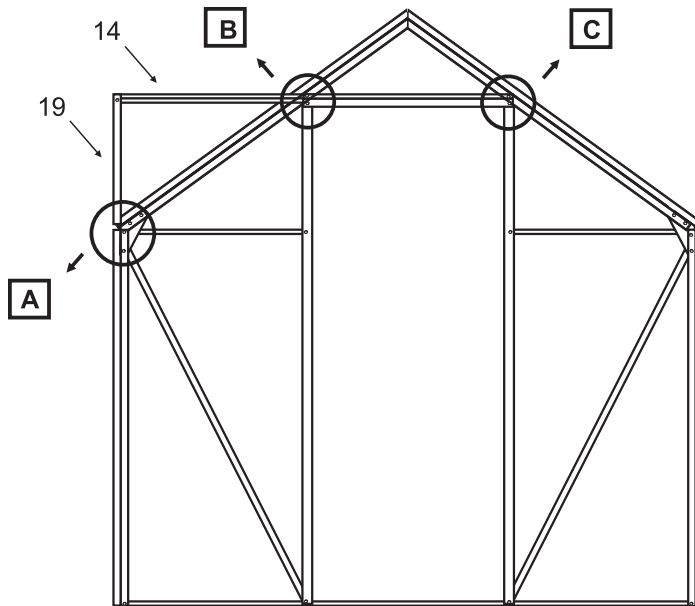
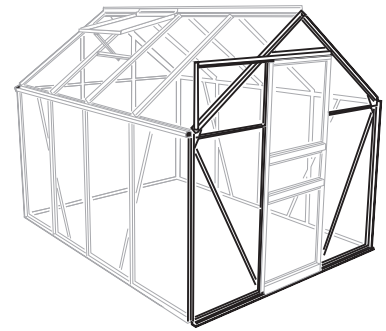
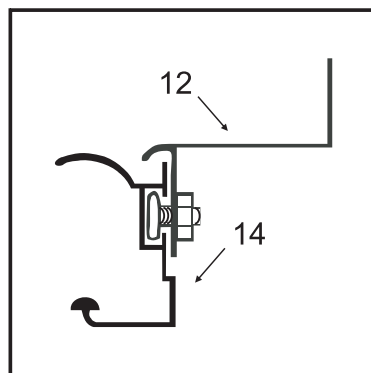

Fig. B and C: Slide through and screw part #14.

(*) Note regarding [A]:

Cover #47 is attached to part #1 and part #3, and then on the other side to part #1 and part #2.



Assembly of the components

- Screw the gable sides and side panels together (Fig. [A] and [B]).

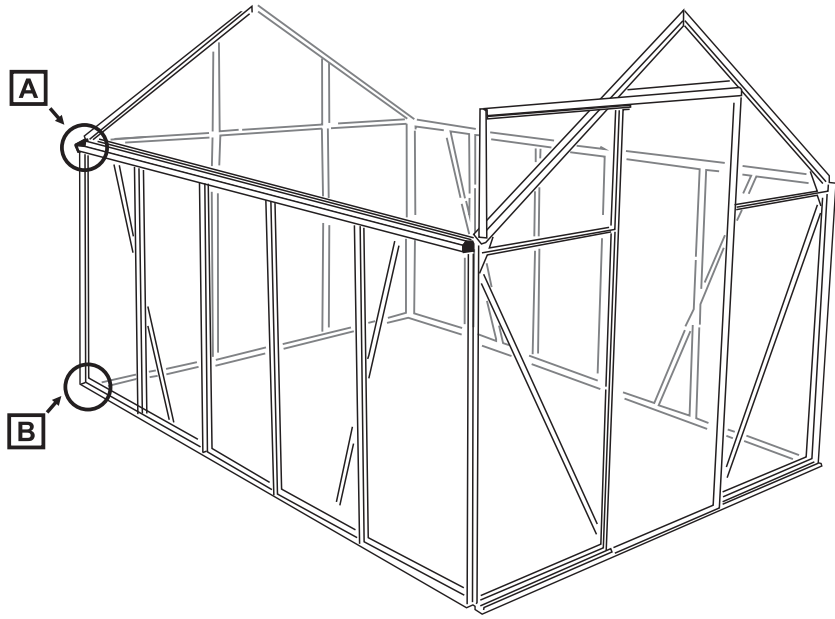
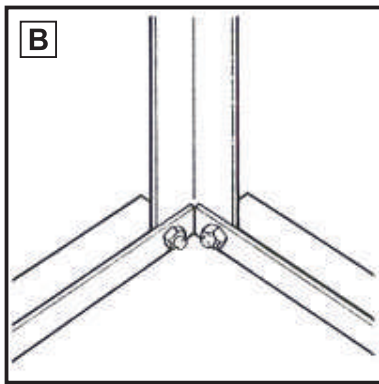
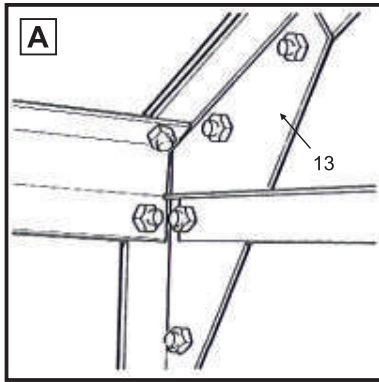

- Secure the roof beam to the two gable sides ([C]).

Note: Only hand-tighten the gable nuts!

(Tighten them securely with part #40 only during final assembly.)

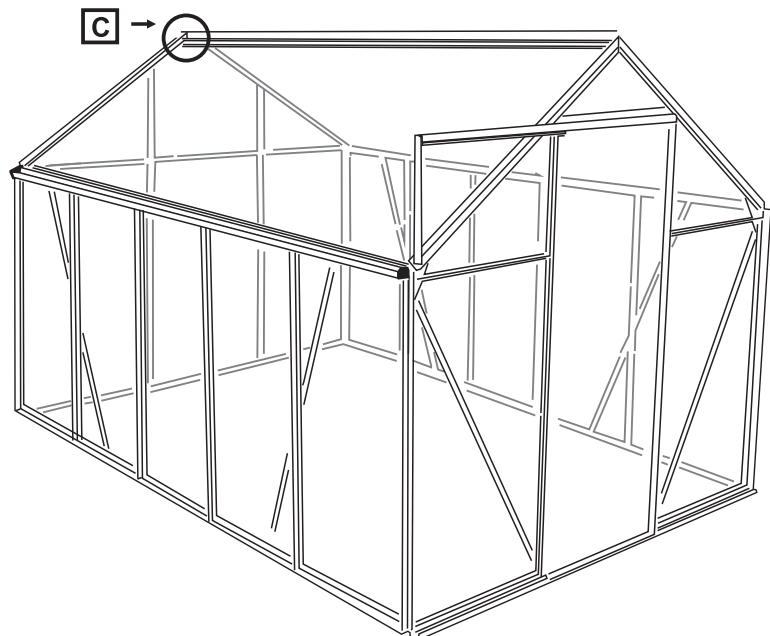
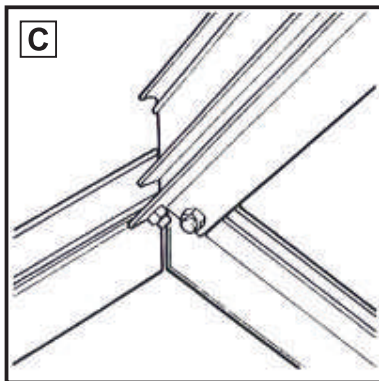

Arrangement of screws:

Screw head on the outside,
nut on the inside.

Note: All detailed illustrations are interior views.

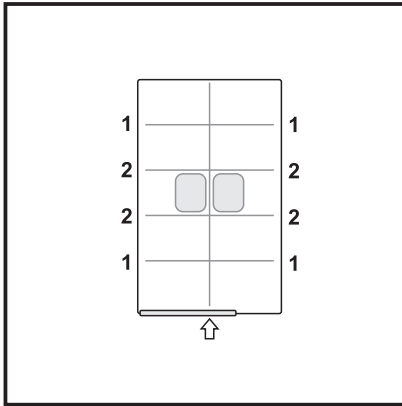

Note:

In the next step, it is necessary to insert additional screws in advance, as shown.

Please pay attention to the number of required extra screws and the position of the corresponding roof profiles (#11).



- Attach the roof profiles (#11) to the roof beam and side walls ([D] + [E]).
- Prior to mounting part #11, insert one screw (#43) each ([D]).
- For the area around brace #58 (page 18, Fig. [A2]), use two screws per profile.

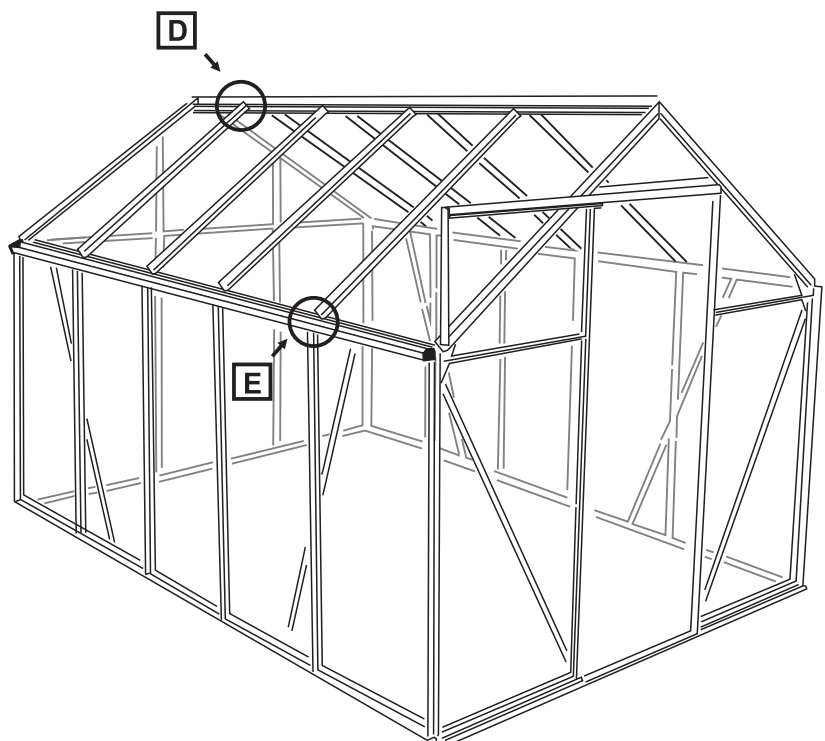
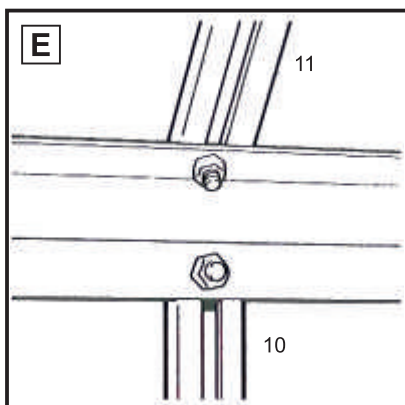
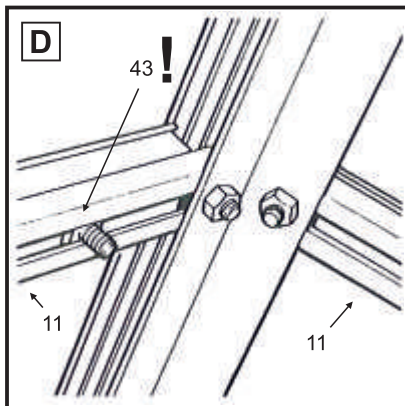

Assembly: Windows

- Attach all window struts (#15) to the roof profiles (#11). ([A])

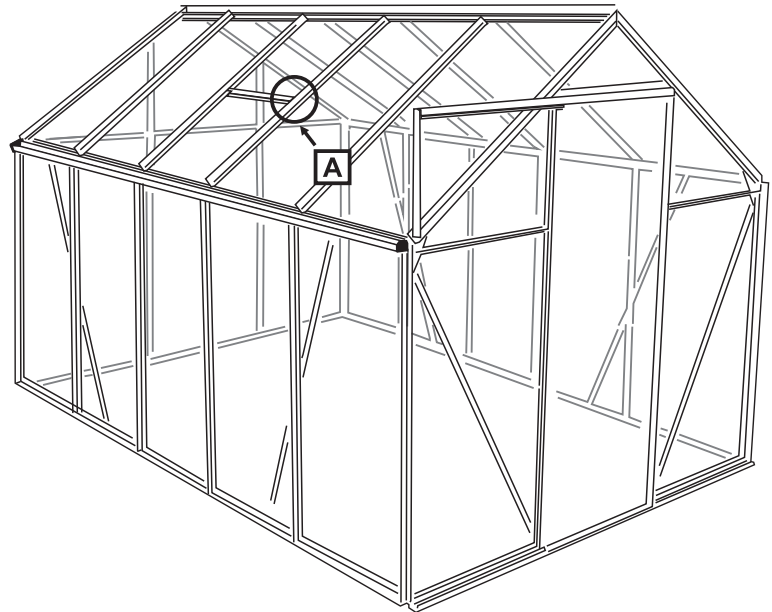
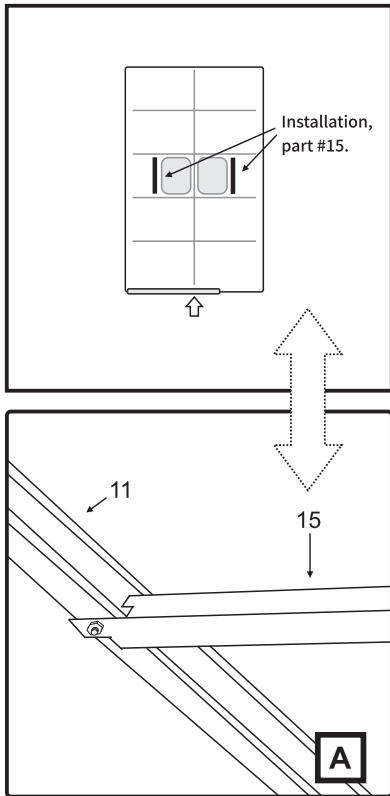

- Reinforce the roof structure using the cross braces (#40) (Fig. [A1]), as well as the roof braces (#58) in the window area ([A2]).

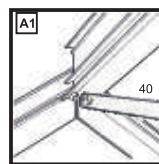
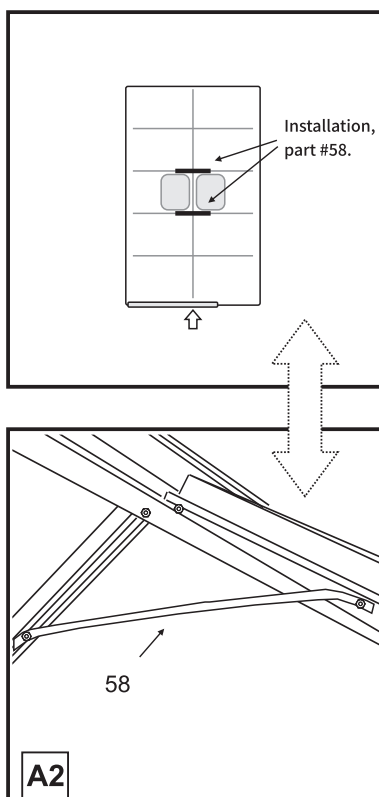

Assembly point, part 40:
existing gable screws.

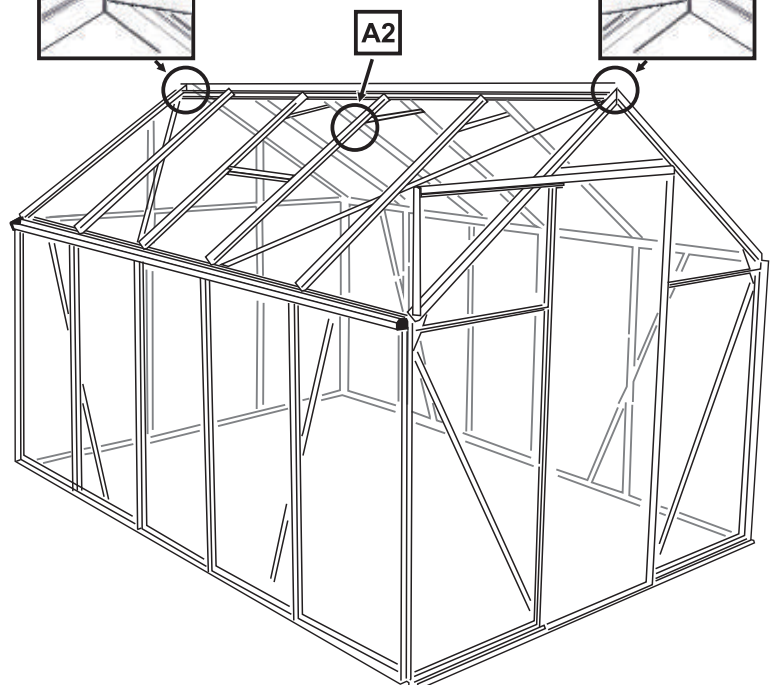
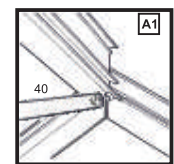

Now follows the assembly of the roof windows.

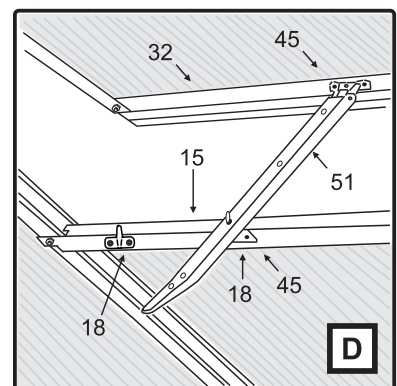
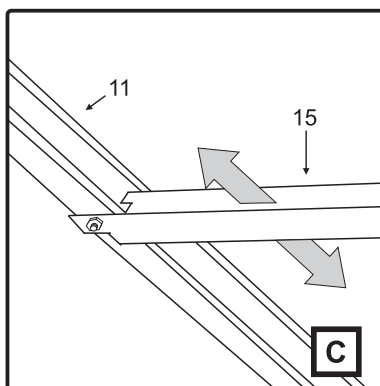
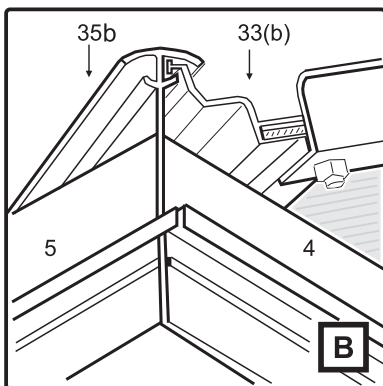
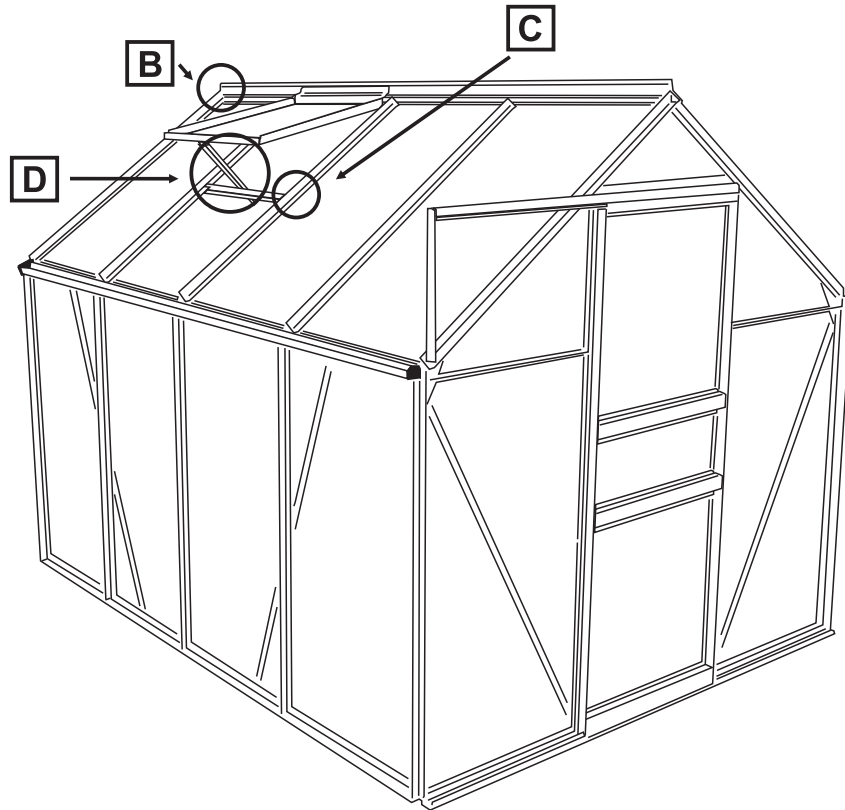

[B]: The upper part of the window must first be inserted at the end of profile #35. Slide the window in the profile until it reaches the designated position.

[C]: Adjust the position of window strut #15 to match the window.

[D]: Secure the brackets (#18) to profile #15 using screw #45.



Part #45,
M4x7.5 screw



Part #18,
holder

Final assembly,

Plate Placement Place the multiwall polycarbonate sheets as listed in step M and secure them using the clips (Part #46).

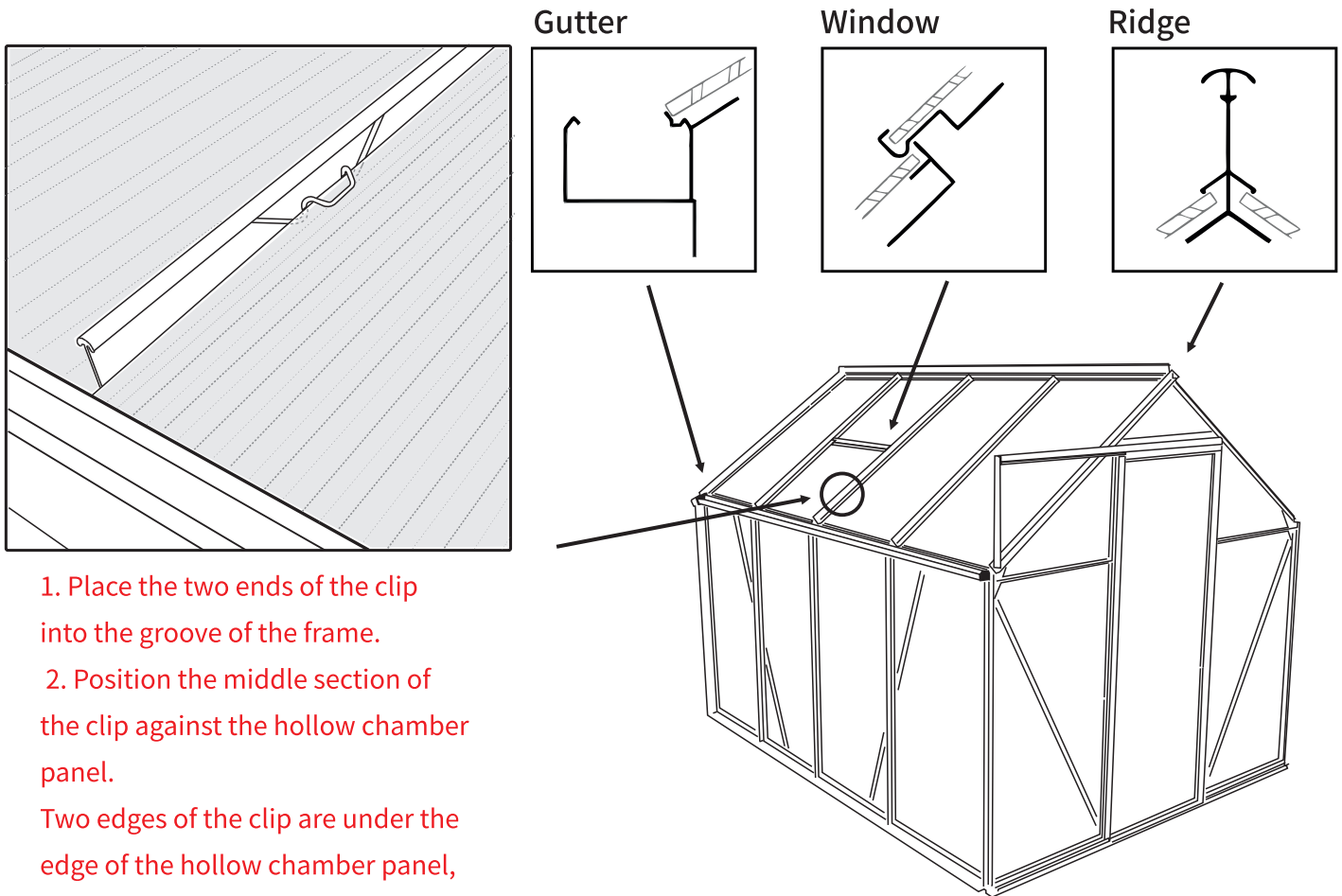

1. Place the two ends of the clip into the groove of the frame.
2. Position the middle section of the clip against the hollow chamber panel.

Two edges of the clip are under the edge of the hollow chamber panel, and the middle edge holds the panel in place.

Important: The sheets are coated with a UV-protective layer on one side. The side with the white film must be placed inwardly to ensure UV protection! Peel off the white film! The transparent film can be left as a protective film or optionally removed (e.g., in case of dirt).



Safety Precaution:

Please be sure to install the wind clips and fastening clips by strictly following the instructions. The manufacturer will not be liable for any damage or loss resulting from improper installation that causes reduced wind resistance or the PC panels to fall off.

Arrangement of the multiwall polycarbonate sheets

Gable sides:

Sheet No. 3, 6, and 10 are each connected to Sheet No. 1 using Part #41 - as shown in the illustration.

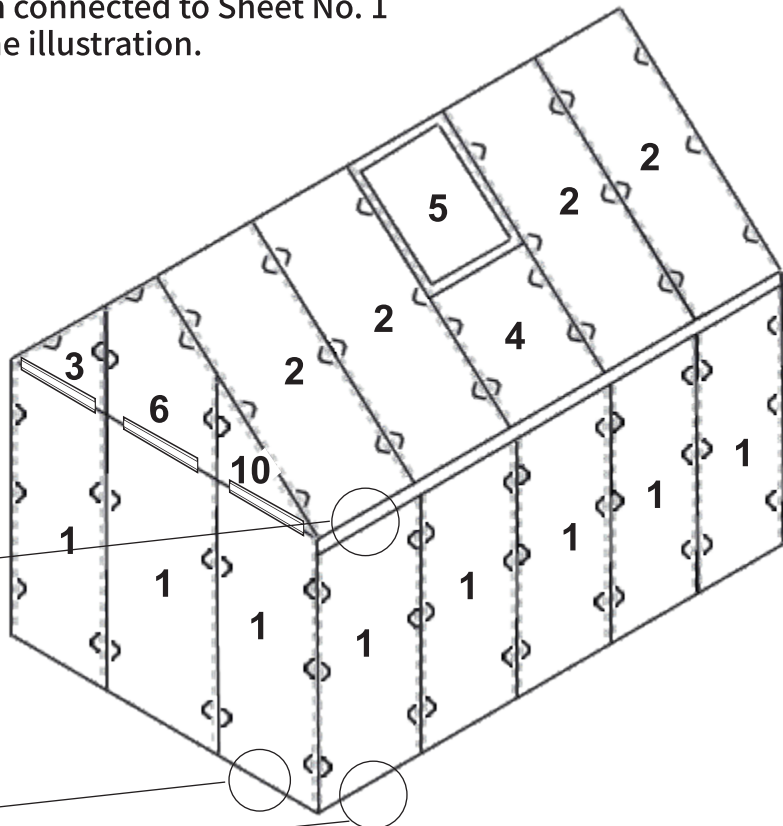
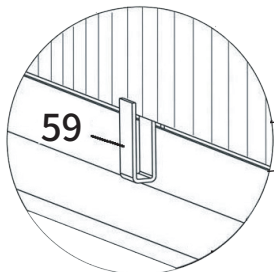
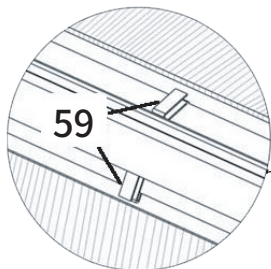
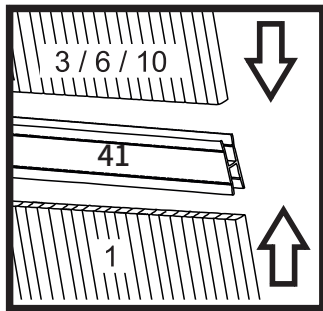

Please pay attention to the UV protection notice.

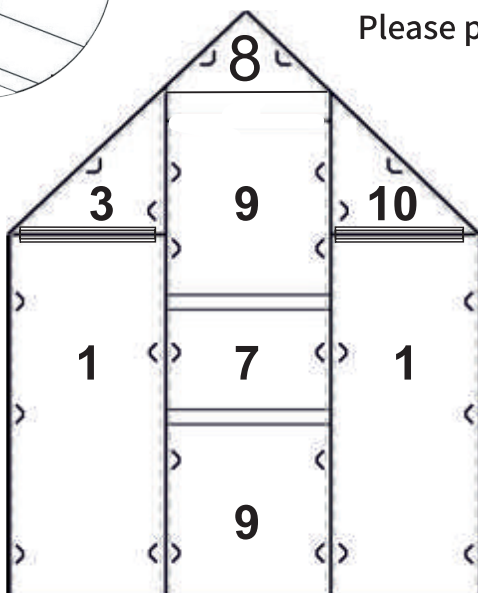

| Item NO. | Size (mm) | Quantity |
|----------|------------|----------|
| 1 | 605 x 1210 | 15 |
| 2 | 605 x 1130 | 8 |
| 3 | 605 x 450 | 2 |
| 4 | 605 x 590 | 2 |
| 5 | 600 x 549 | 2 |
| 6 | 605 x 662 | 1 |
| 7 | 610 x 224 | 1 |
| 8 | 615 x 232 | 1 |
| 9 | 610 x 602 | 2 |
| 10 | 605 x 450 | 2 |

After 24 hours, recheck all screws and tighten if necessary.

Final assembly, door.

The assembly of the door is done last.

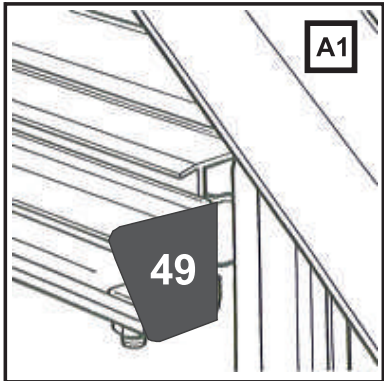
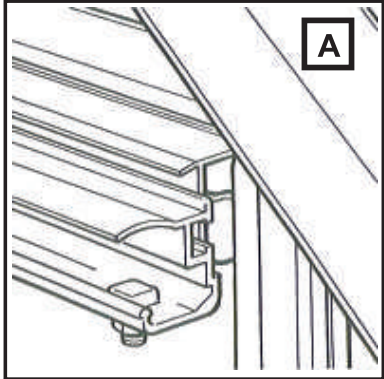
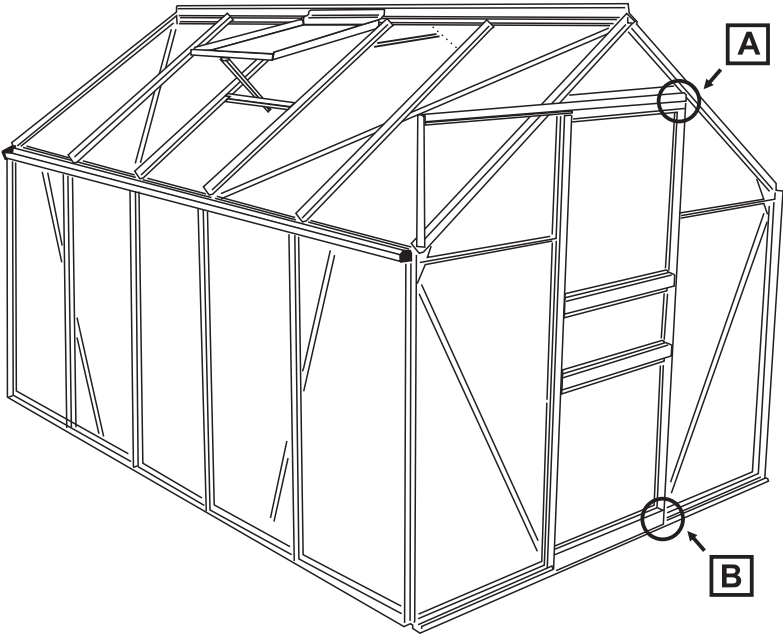
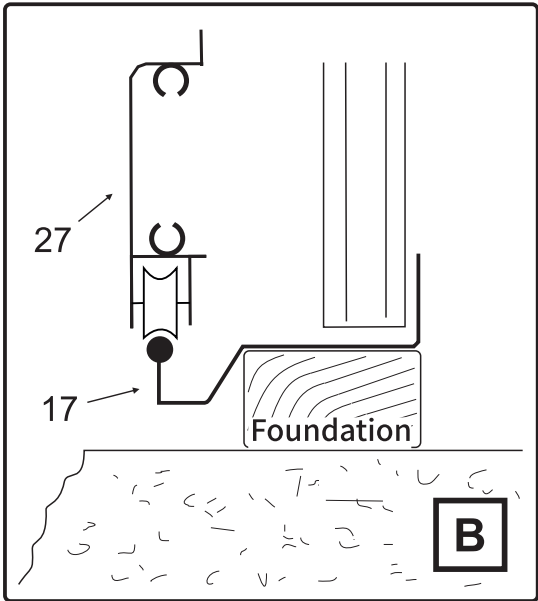

Fig. [A1]: Attach cover (#49) only after final assembly. Cover #50 is mounted opposite.

[A] / [B]: Insert the door into the upper and lower guide rail (#17, Fig. [B]). Attach a nut and screw at the end of the upper guide rail (#14, Fig. [A]). It serves as a stopper for the door.



HELP CENTER



Inquiry



Assembly issue



Missing parts

If you encounter any difficulties during assembly, please contact us.

Wenn Sie während der Montage auf Schwierigkeiten stoßen, kontaktieren Sie uns bitte.

Si vous rencontrez des difficultés lors du montage, veuillez nous contacter.

Se incontri difficoltà durante il montaggio, ti preghiamo di contattarci.

Si encuentras alguna dificultad durante el ensamblaje, por favor contáctanos.

DISCLAIMER

Manufacturer and seller expressly disclaim any and all liability for personal injury, property damage or loss, whether direct, indirect, or incidental, resulting from the incorrect attachment, improper use, inadequate maintenance, unapproved modification, or neglect of this product.

Der Hersteller und Verkäufer lehnen ausdrücklich jegliche Haftung für Personenschäden, Sachschäden oder Verluste ab, egal ob direkt, indirekt oder zufällig, die durch falsche Anbringung, unsachgemäßen Gebrauch, unzureichende Wartung, nicht genehmigte Änderungen oder Vernachlässigung dieses Produkts entstehen.

El fabricante y vendedor renuncian expresamente a toda responsabilidad por lesiones personales, daños materiales o pérdidas, ya sean directos, indirectos o incidentales, derivados de la incorrecta colocación, uso inadecuado, mantenimiento insuficiente, modificación no aprobada o negligencia de este producto.

Il produttore e il venditore declinano espressamente ogni responsabilità per lesioni personali, danni materiali o perdite, dirette, indirette o incidentali, derivanti dall'errato fissaggio, uso improprio, manutenzione inadeguata, modifica non autorizzata o negligenza di questo prodotto. Le fabricant et le vendeur déclinent expressément toute responsabilité en cas de blessures corporelles, de dommages matériels ou de pertes, qu'ils soient directs, indirects ou accessoires, résultant de la fixation incorrecte, de l'utilisation inappropriée, de l'entretien insuffisant, de la modification non approuvée ou de la négligence de ce produit.