

# Cabinet Manual

---



Thank you for purchase on our products. Please contact us if you have difficulty with assembly or need replacement parts. Our customer service is here to assist you. Please attach your User Name or Order ID so that we can assist you better.

Vielen Dank für Ihren Kauf von uns Produkten. Bitte kontaktieren Sie uns, wenn Sie Probleme mit Montage haben oder Ersatzteile benötigen. Wir Kundenservice ist für Sie da. Bitte geben Sie Ihren Benutzernamen oder Ihre Bestellnummer an, damit wir Sie besser unterstützen können.

**EN**

## **WARNING**

Serious or fatal injury may occur from unexpected assembly or use.

1. During the assembly process, keep all parts away from babies or children.
2. Always securely fix this product to the wall. Make sure the wall area to be drilled is free from hidden electrical wires, water and gas pipes.
3. Use of tip-over restraints may only reduce, but not eliminate the risk of tip-over.
4. Unless specially designed to accommodate, do not set heavy objects on top of this product.
5. Place the heaviest items on the lowest shelf.
6. Never allow children to climb or bang on drawers, doors or shelves.

**DE**

## **WARNUNG**







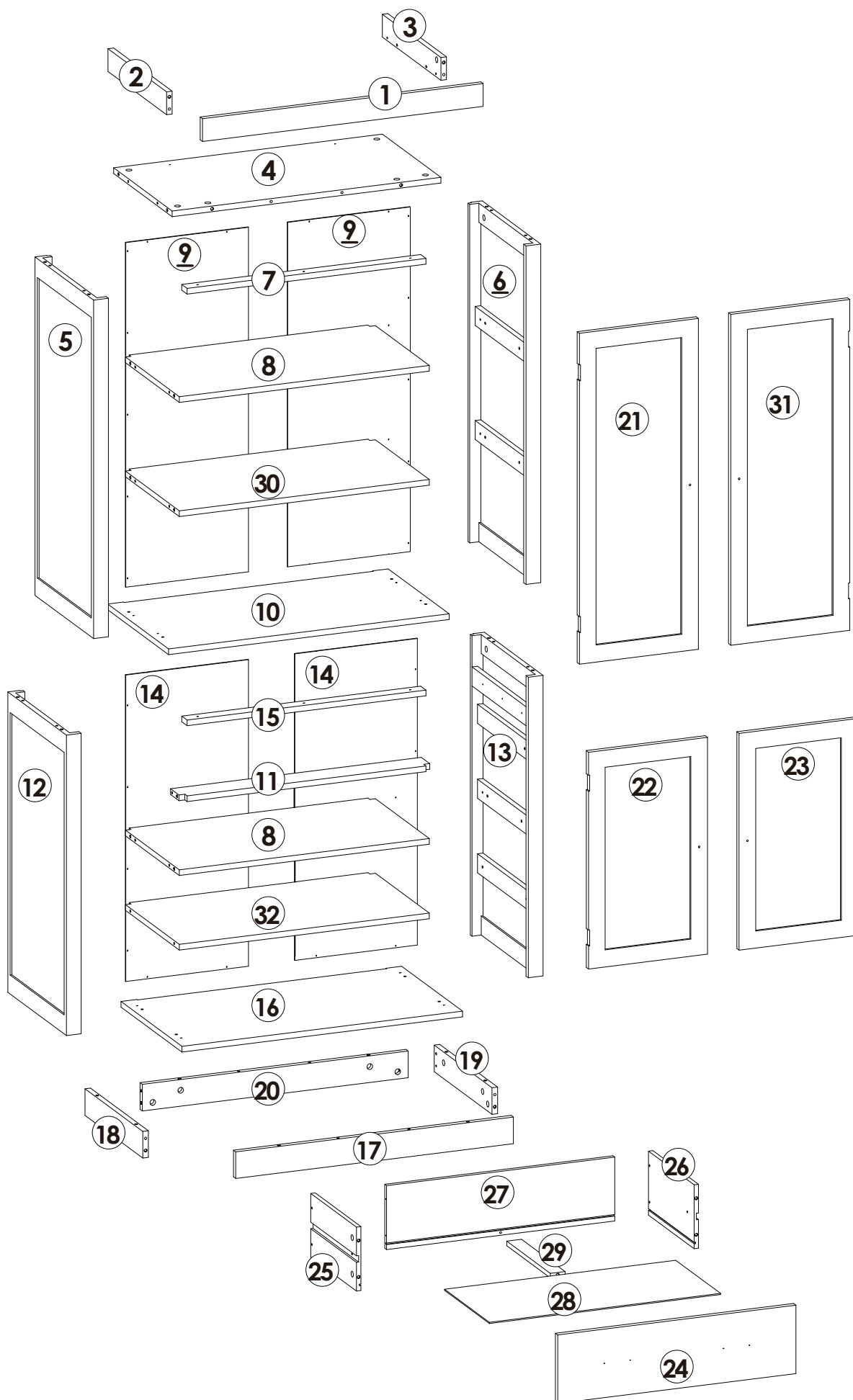

Bei unerwarteter Montage oder Verwendung können schwere oder tödliche Verletzung auftreten.

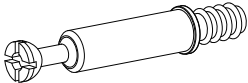
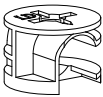
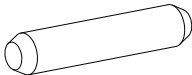
1. Legen Sie in den Montageprozess alle Teile weg von Babys oder Kindern.
2. Stellen Sie sicher, dass der gebohrte Wandbereich frei von verborgenen Stromkabeln, Wasser- und Gasleitungen ist, wenn Sie dieses Produkt an der Wand befestigen.
3. Die Verwendung von Kippsicherungen kann die Gefahr eines Kippens nur verringern, jedoch nicht beseitigen.
4. Setzen Sie bitte keine schweren Gegenstände auf dieses Produkt, es sei denn, dass das Produkt speziell für die Unterbringung konzipiert wird.
5. Legen Sie bitte die schwersten Gegenstände auf das unterste Regal.
6. Erlauben Sie nie Kindern, auf Schubladen, Türen oder Regale zu klettern oder zu knallen.

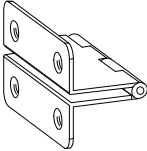
# Parts List(EN) / Teile Liste(DE)

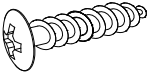
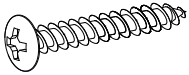
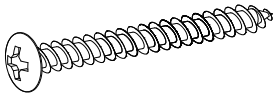
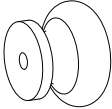
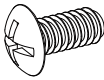
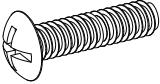
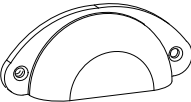
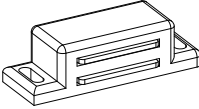
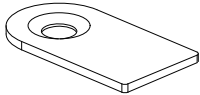

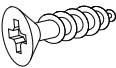
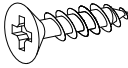
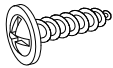
## Parts List(EN) / Teile Liste(DE)

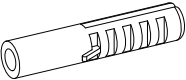
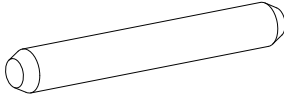
<p><b>A</b></p>  <p>M6×35mm 47+2PCS</p>	<p><b>B</b></p>  <p>Φ15×10mm 47+2PCS</p>	<p><b>C</b></p>  <p>Φ6×30mm 42+2PCS</p>	<p><b>D</b></p>  <p>790mm 1PC</p>
<p><b>E</b></p>  <p>890mm 1PC</p>	<p><b>F</b></p>  <p>8PCS</p>	<p><b>G</b></p>  <p>M4×12mm 2PCS</p>	<p><b>H</b></p>  <p>M4×25mm 6PCS</p>
<p><b>I</b></p>  <p>M4×30mm 7PCS</p>	<p><b>J</b></p>  <p>M4×45mm 8+1PCS</p>	<p><b>K</b></p>  <p>4PCS</p>	<p><b>L</b></p>  <p>M4×10mm 2PCS</p>
<p><b>M</b></p>  <p>M4×18mm 4PCS</p>	<p><b>N</b></p>  <p>2PCS</p>	<p><b>O</b></p>  <p>3PCS</p>	<p><b>P</b></p>  <p>6PCS</p>
<p><b>Q</b></p>  <p>2PCS</p>	<p><b>R</b></p>  <p>M3×12mm 50+2PCS</p>	<p><b>S</b></p>  <p>M4×15mm 4PCS</p>	<p><b>T</b></p>  <p>M2.5×12mm 42+2PCS</p>
<p><b>U</b></p>  <p>2PCS</p>	<p><b>V</b></p>  <p>2PCS</p>	<p><b>W</b></p>  <p>Φ6×50mm 4PCS</p>	

# Assembly Steps(EN) / Montageschritte(DE)

## STEP 1

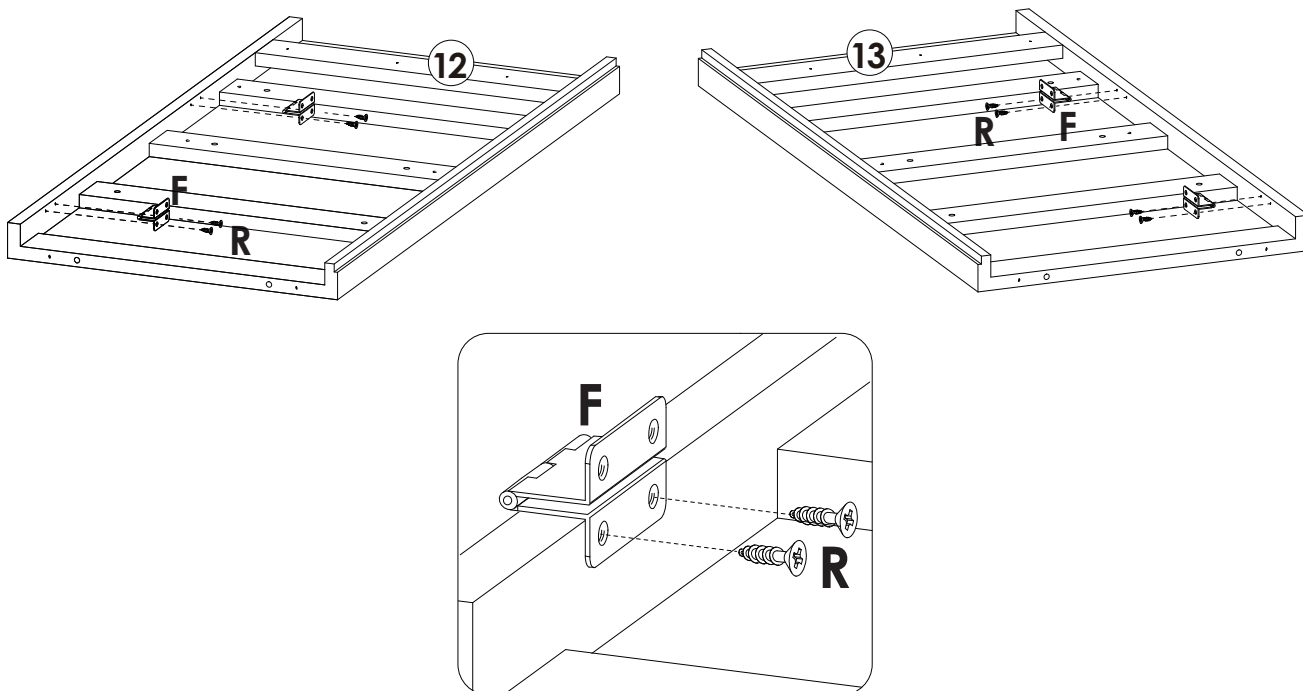

	<b>F</b> x 4PCS
	<b>R</b> x 8PCS

## STEP 2

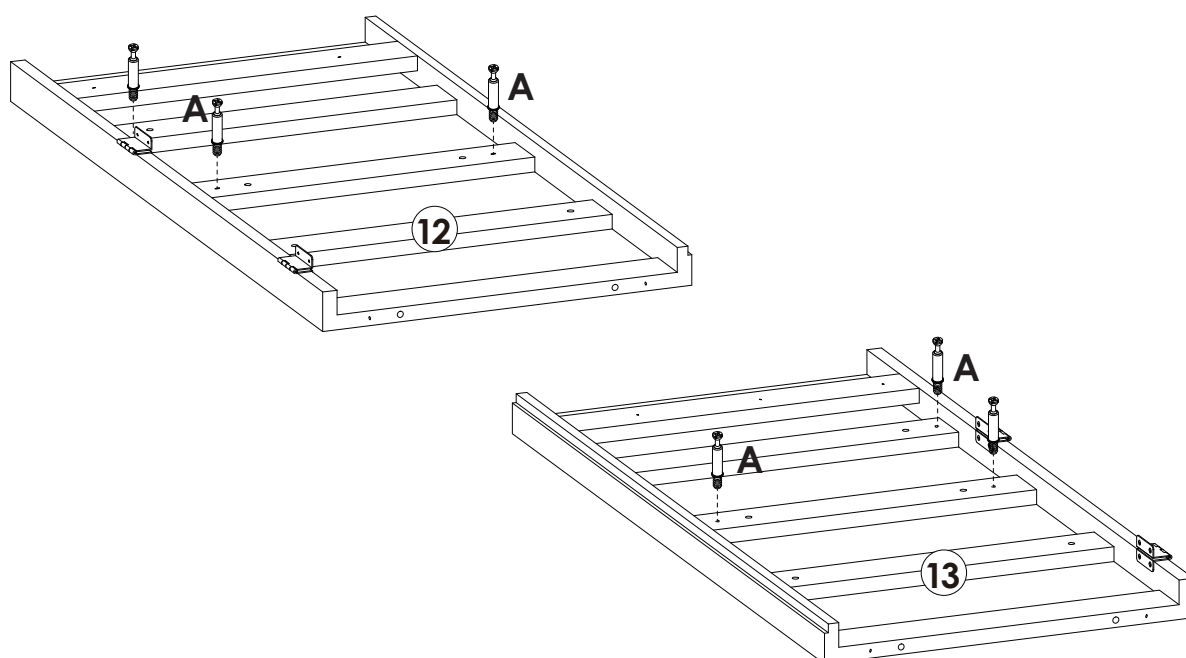

	<b>A</b> x 6PCS
---	-----------------

# Assembly Steps(EN) / Montageschritte(DE)

## STEP 3

a.

Head

Tail

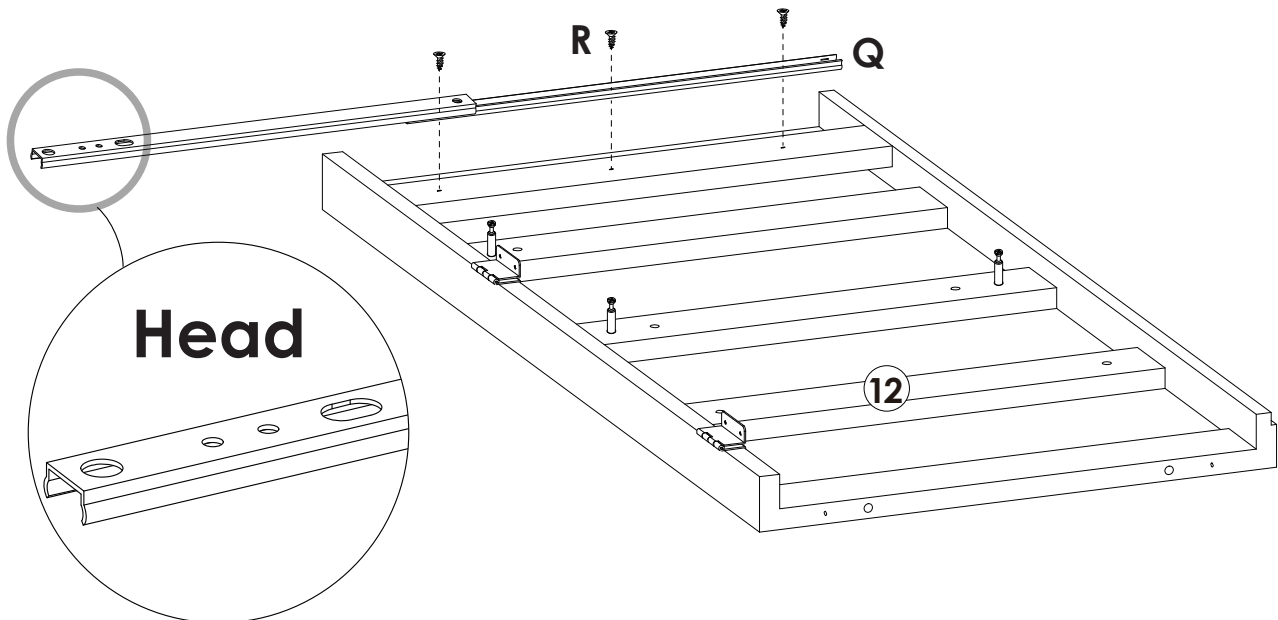
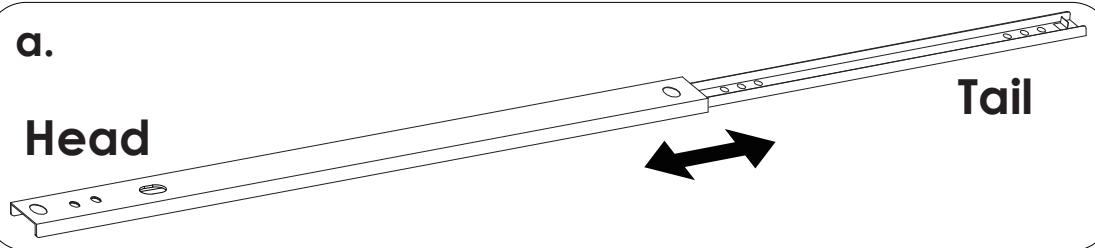

b.

Head

Q

R

Tail

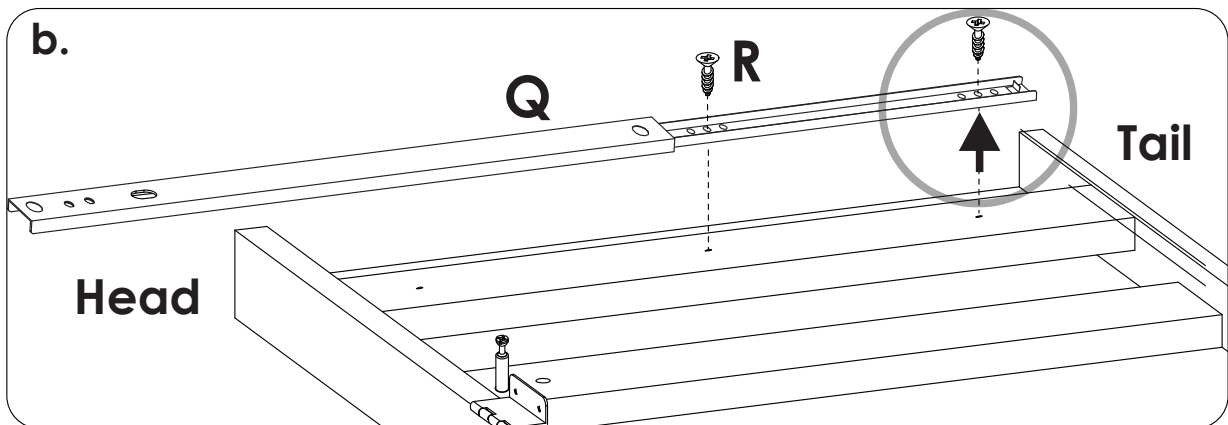

c.



Head

R

Q

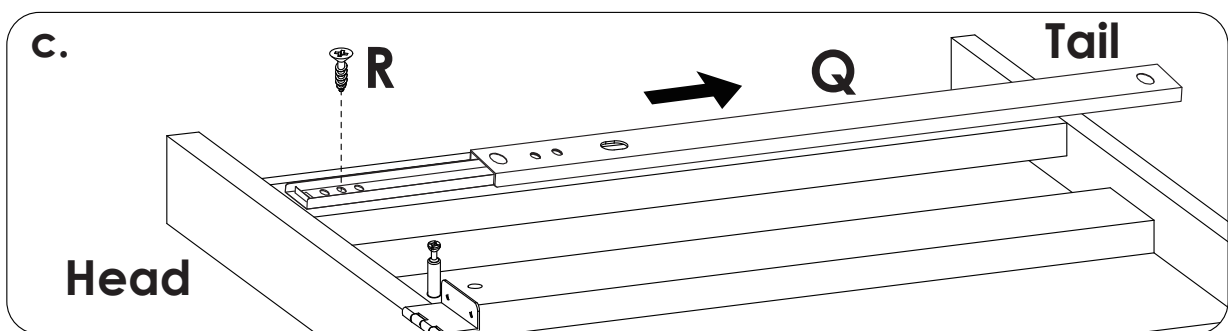
Tail



	R x 3PCS
	Q x 1PC

# Assembly Steps(EN) / Montageschritte(DE)

## STEP 4

a.

Tail

Head

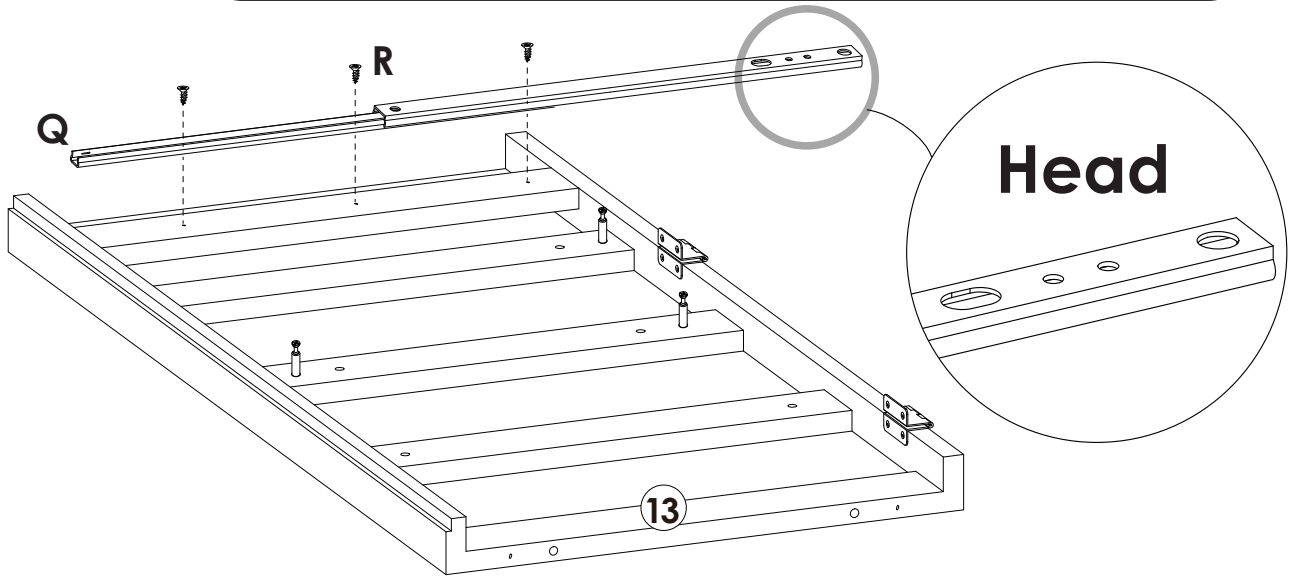

Head

13

b.

R

Q

Head

Tail

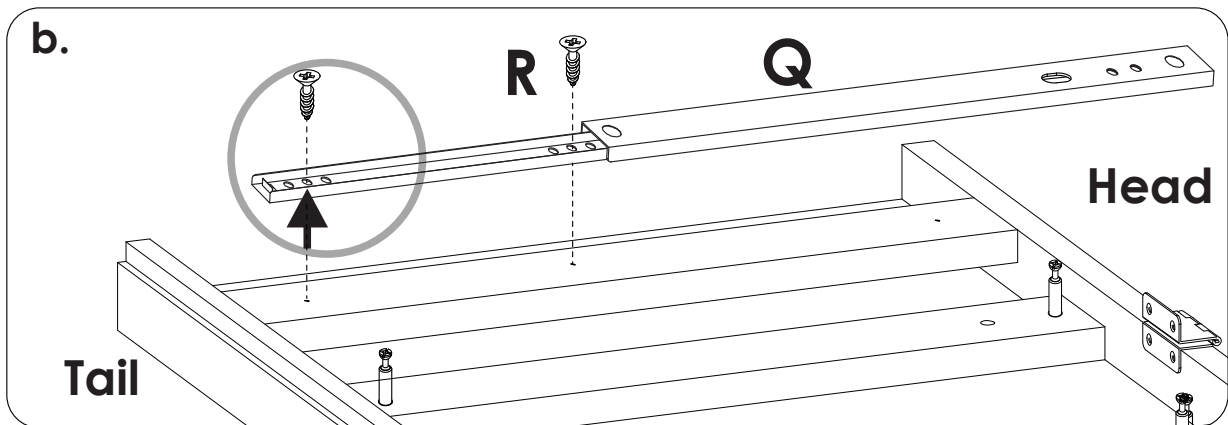

c.

Q

R

Head

Tail

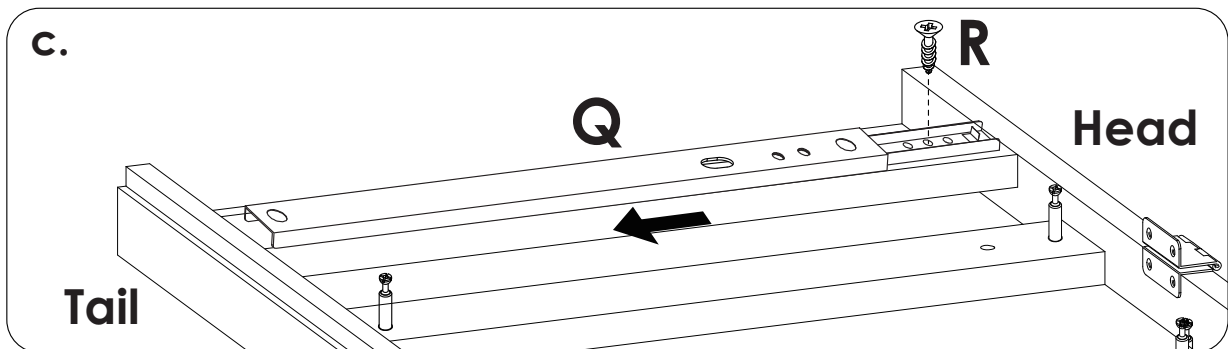

R x 3PCS





Q x 1PC

# Assembly Steps(EN) / Montageschritte(DE)

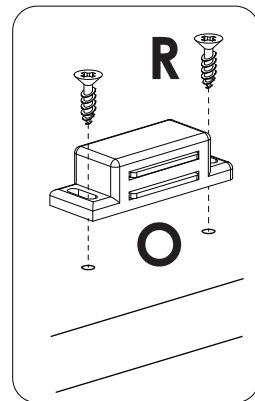
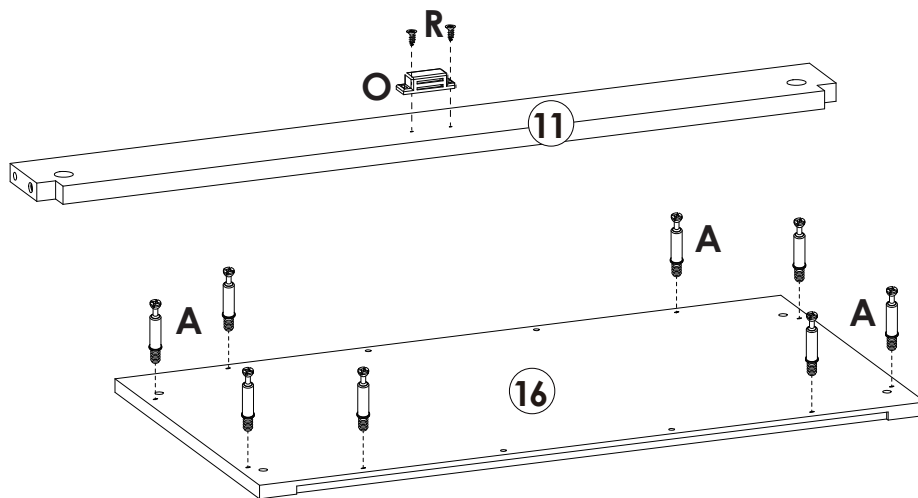
## STEP 5

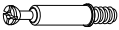

	A x 8PCS
	O x 1PC
	R x 2PCS

## STEP 6

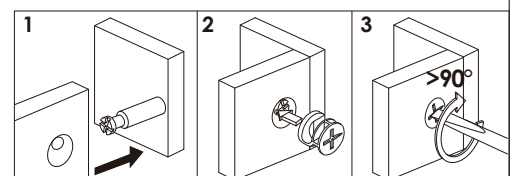
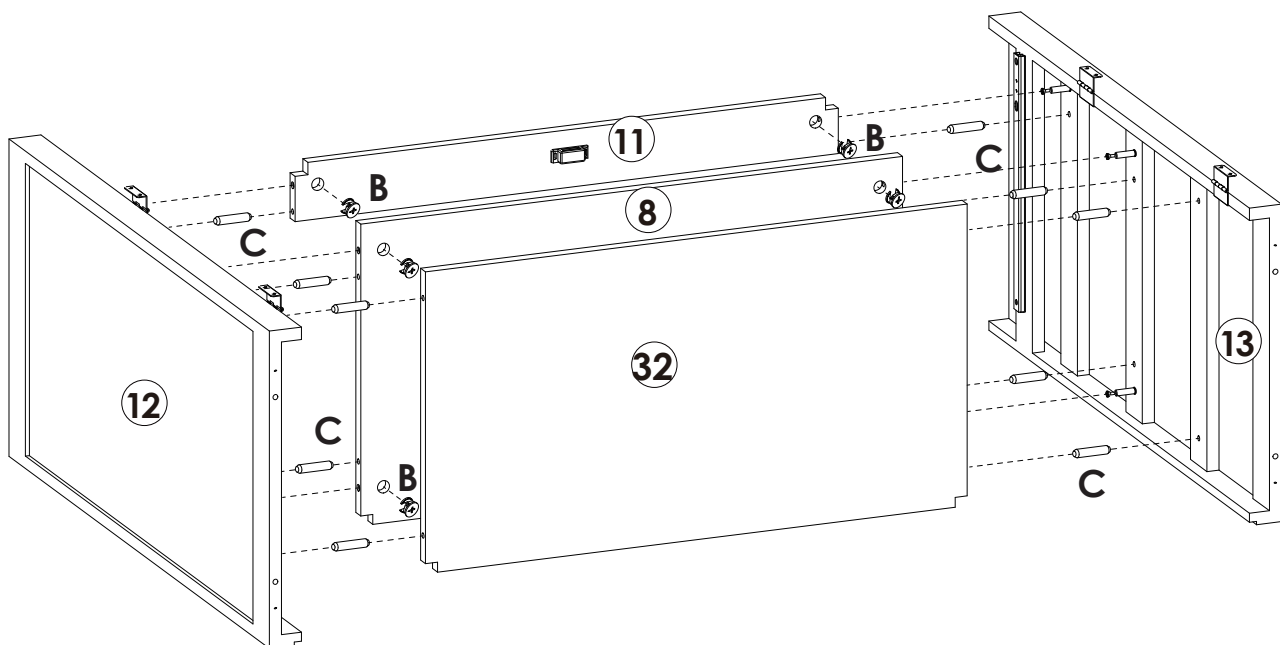

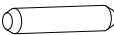
	B x 6PCS
	C x 10PCS

# Assembly Steps(EN) / Montageschritte(DE)

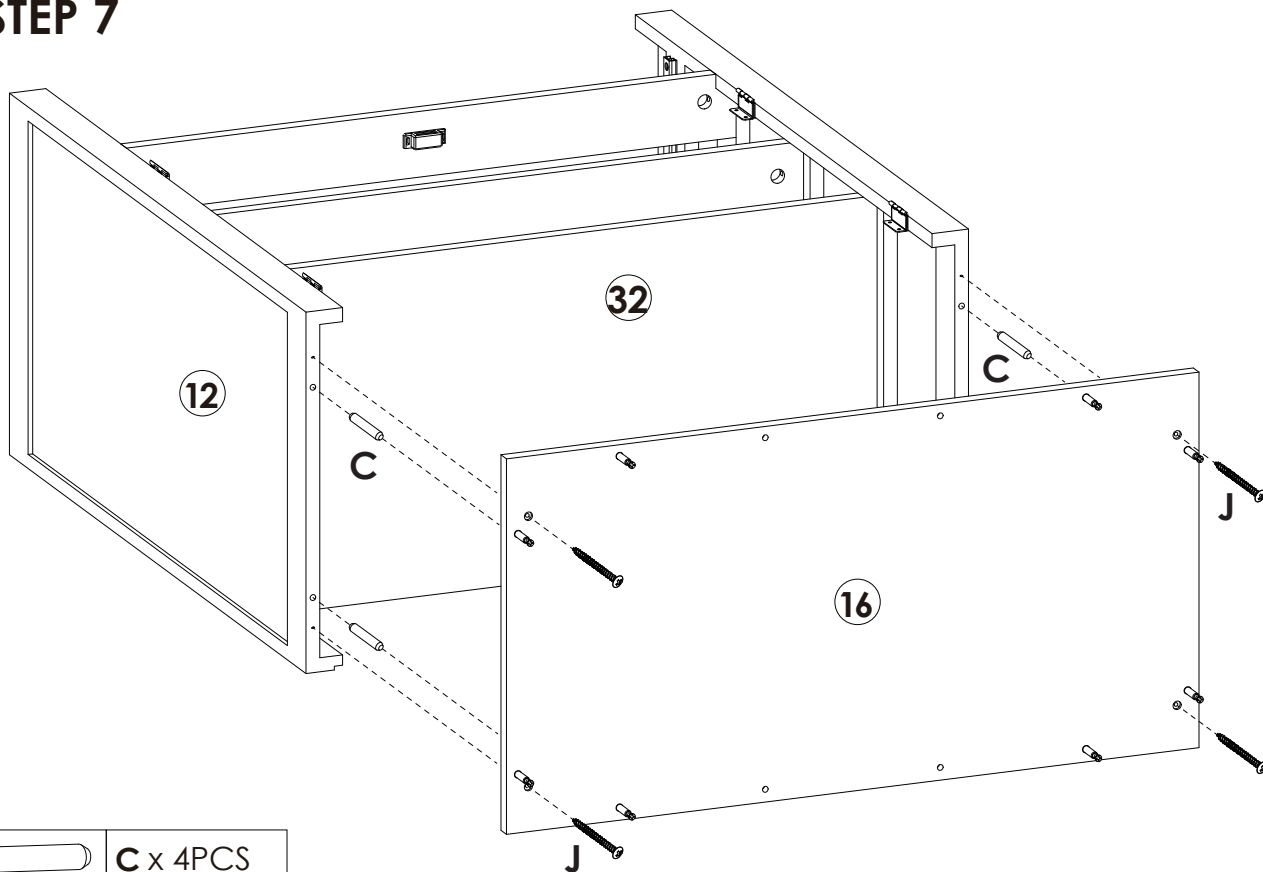

## STEP 7

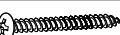

	C x 4PCS
	J x 4PCS

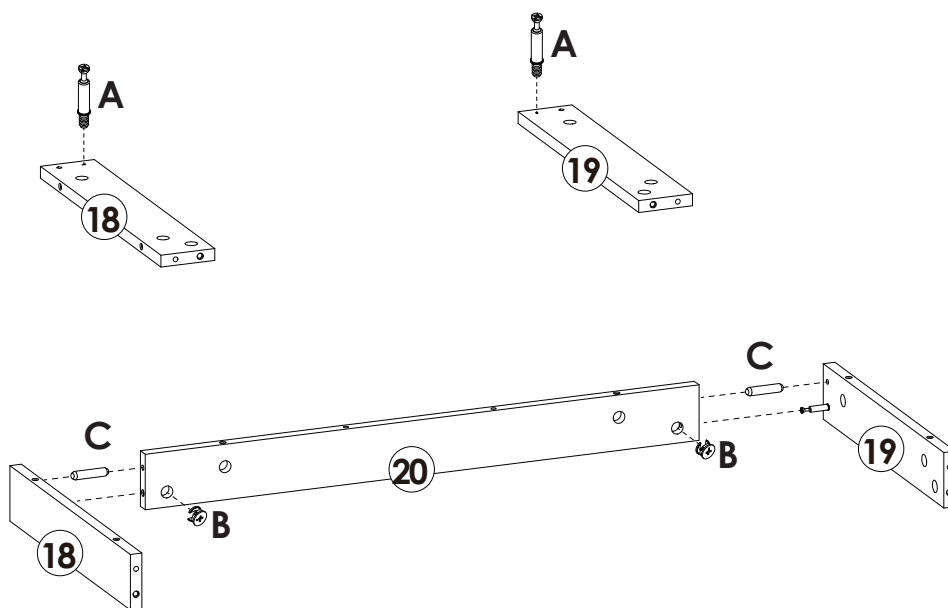
## STEP 8



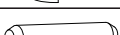

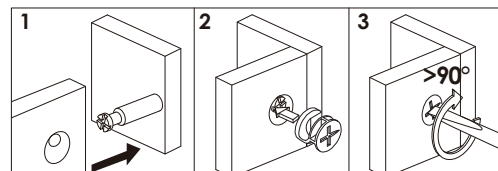
	A x 2PCS
	B x 2PCS
	C x 2PCS

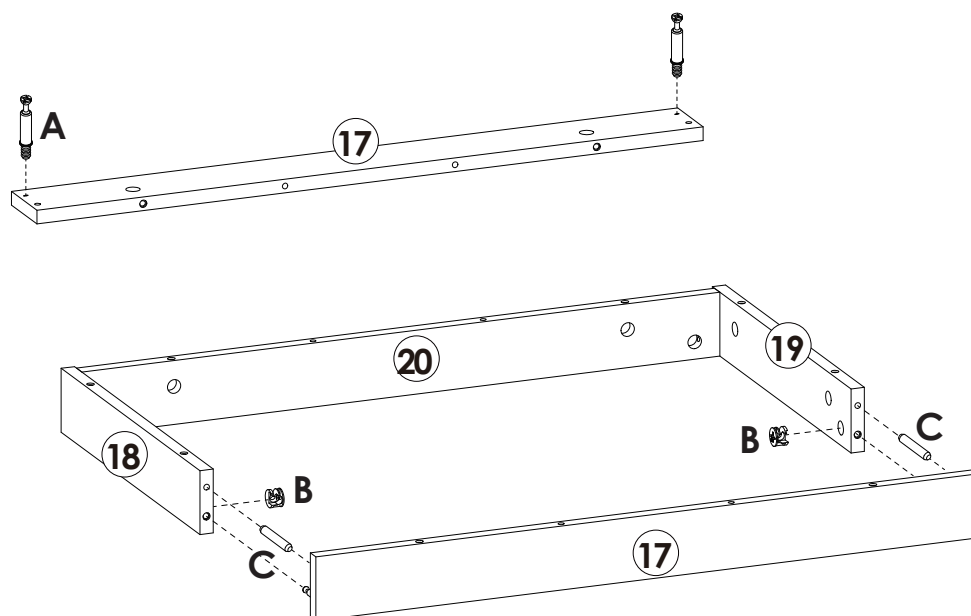

# Assembly Steps(EN) / Montageschritte(DE)

## STEP 9

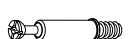

	<b>A x 2PCS</b>
	<b>B x 2PCS</b>
	<b>C x 2PCS</b>

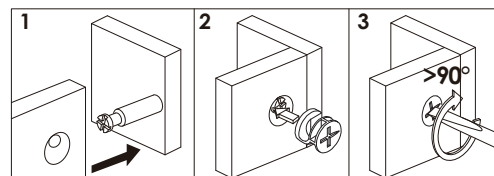

## STEP 10

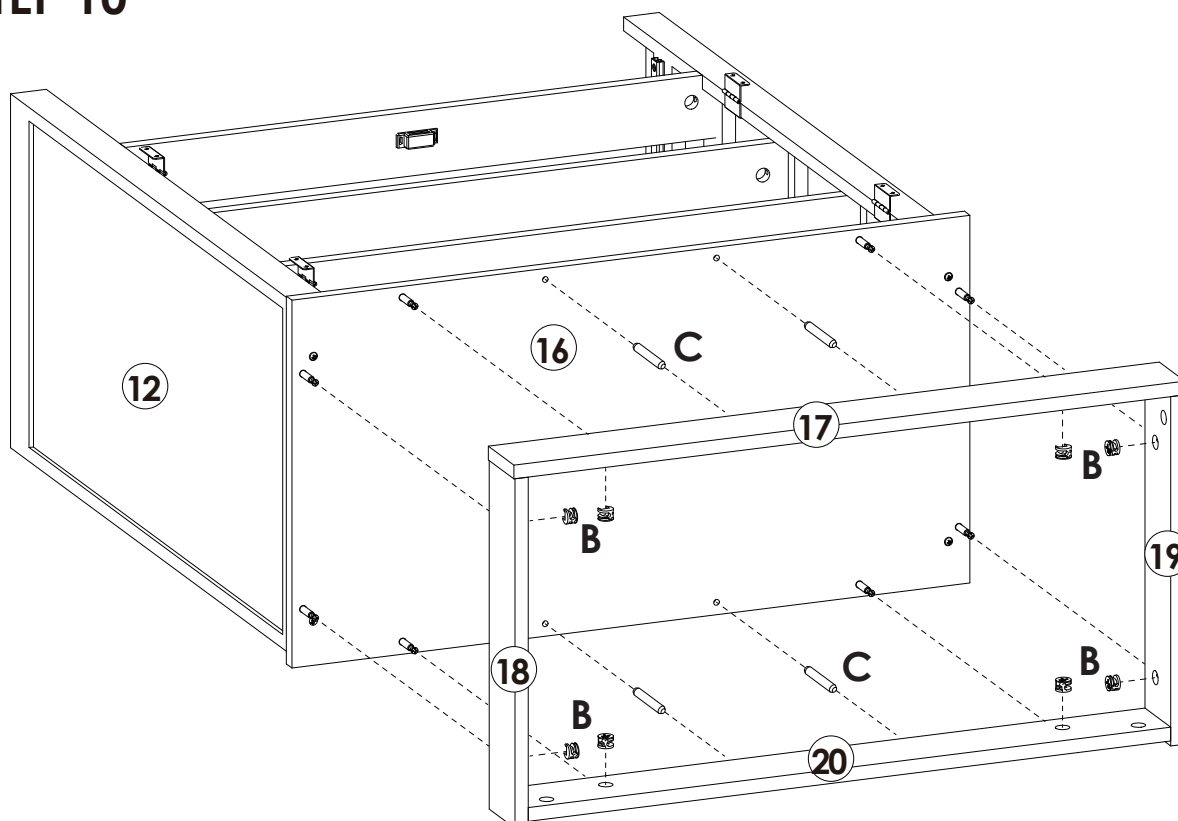

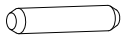

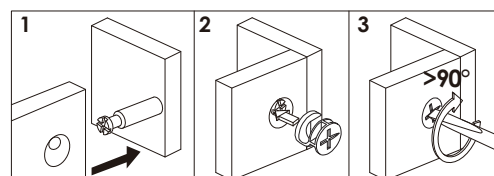

	<b>B x 8PCS</b>
	<b>C x 4PCS</b>

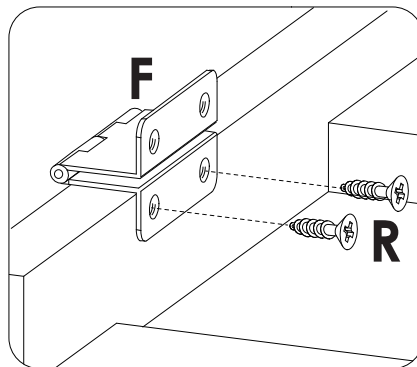
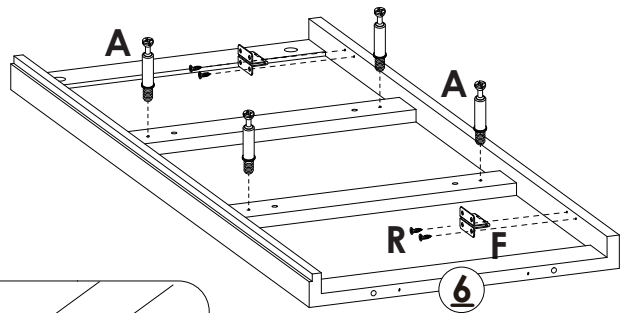
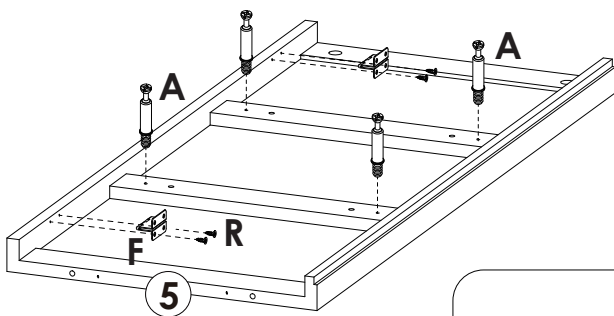

# Assembly Steps(EN) / Montageschritte(DE)



## STEP 11

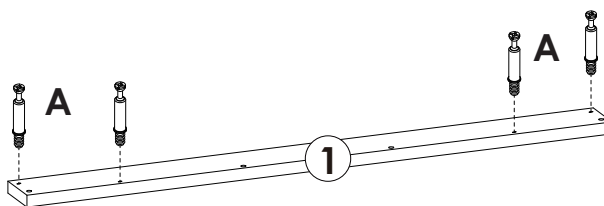
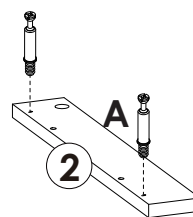
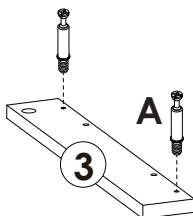
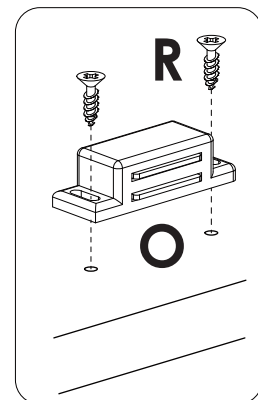
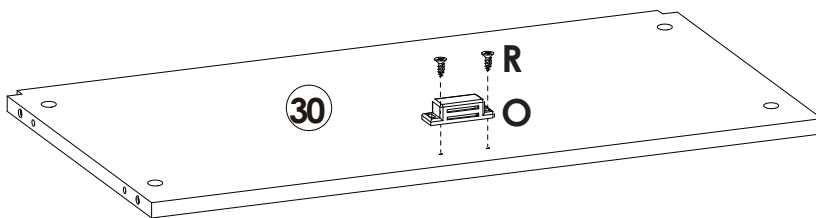

	A x 8PCS
	F x 4PCS
	R x 8PCS

## STEP 12

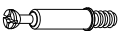



	A x 8PCS
	O x 1PC
	R x 2PCS

# Assembly Steps(EN) / Montageschritte(DE)

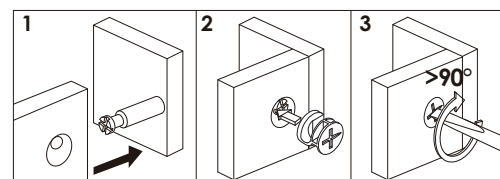
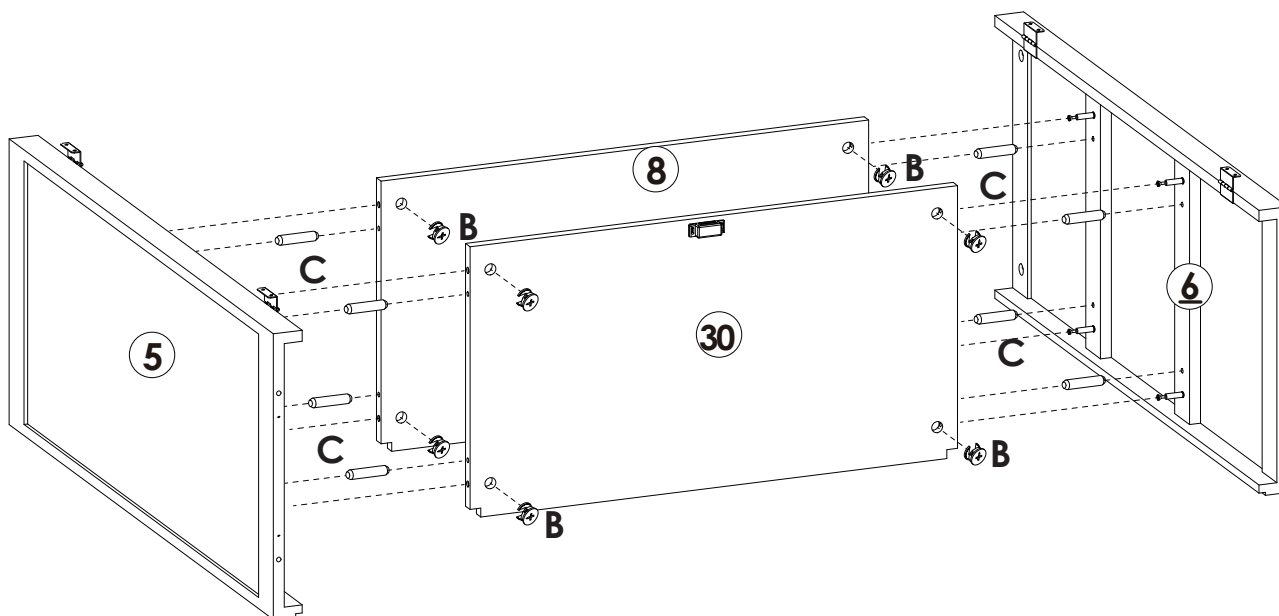
## STEP 13





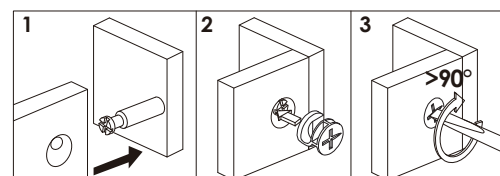
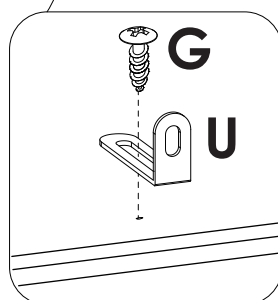
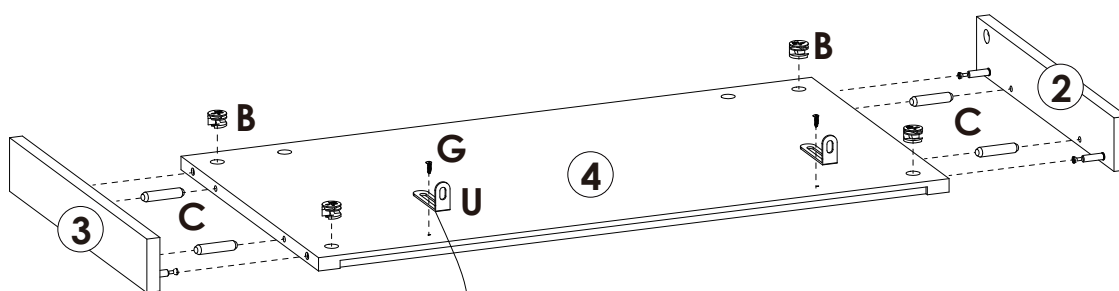

	<b>B</b> x 8PCS
	<b>C</b> x 8PCS

## STEP 14

Lock the long side of the "U" L-shaped metal plate to the ④ board with the "G" short screw



	<b>B</b> x 4PCS
	<b>C</b> x 4PCS
	<b>G</b> x 2PCS
	<b>U</b> x 2PCS

# Assembly Steps(EN) / Montageschritte(DE)

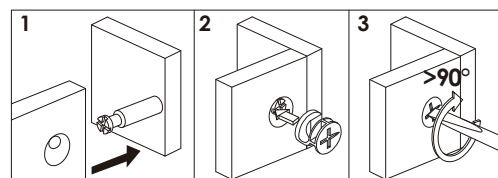
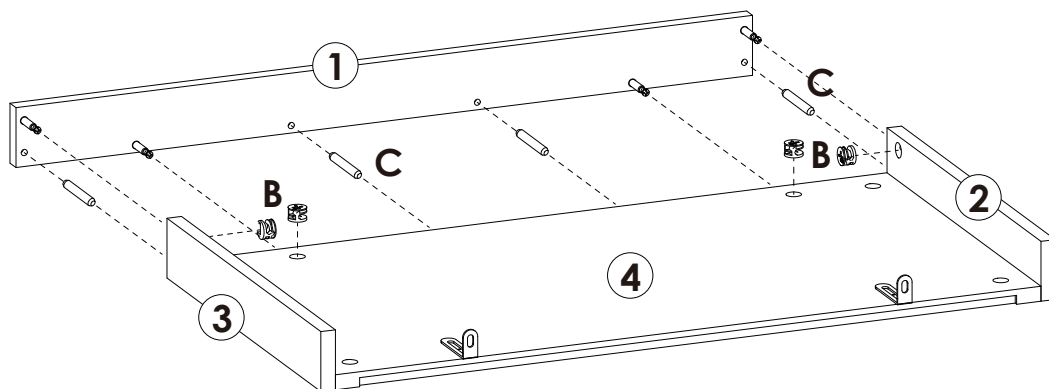

## STEP 15

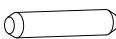

	<b>B</b> x 4PCS
	<b>C</b> x 4PCS

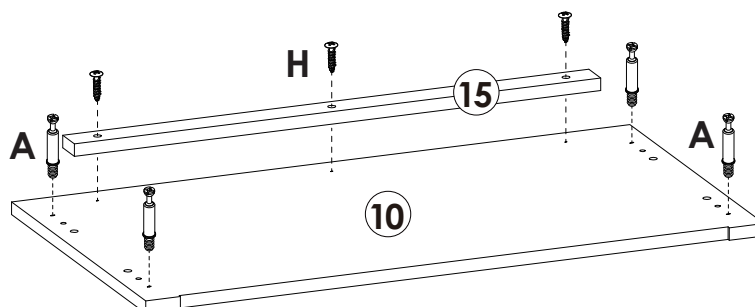
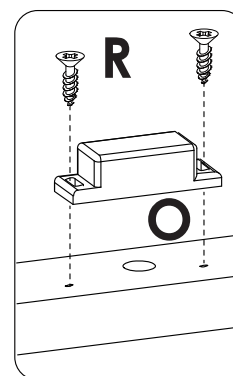
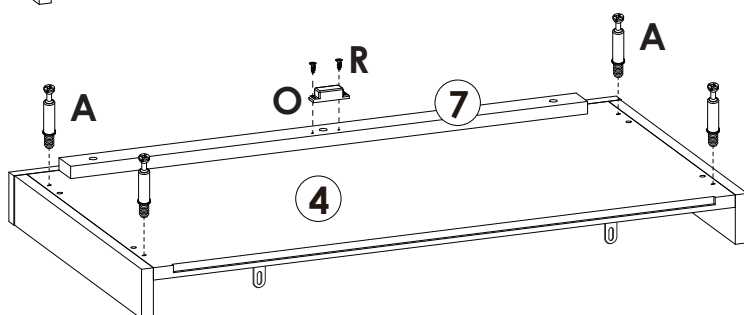
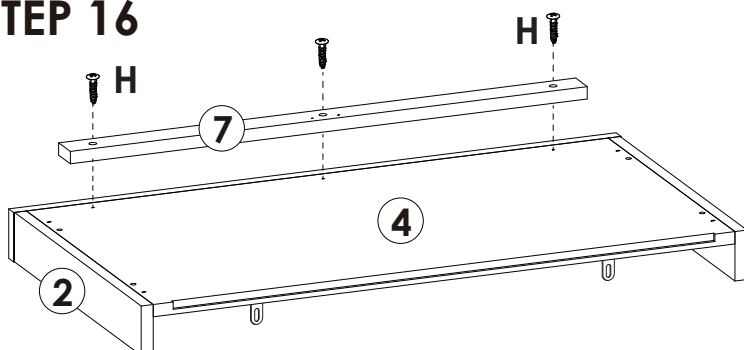
## STEP 16

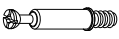

	<b>H</b> x 6PCS
	<b>A</b> x 8PCS
	<b>O</b> x 1PC
	<b>R</b> x 2PCS

# Assembly Steps(EN) / Montageschritte(DE)

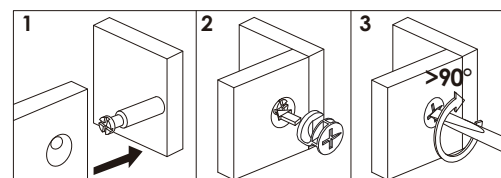
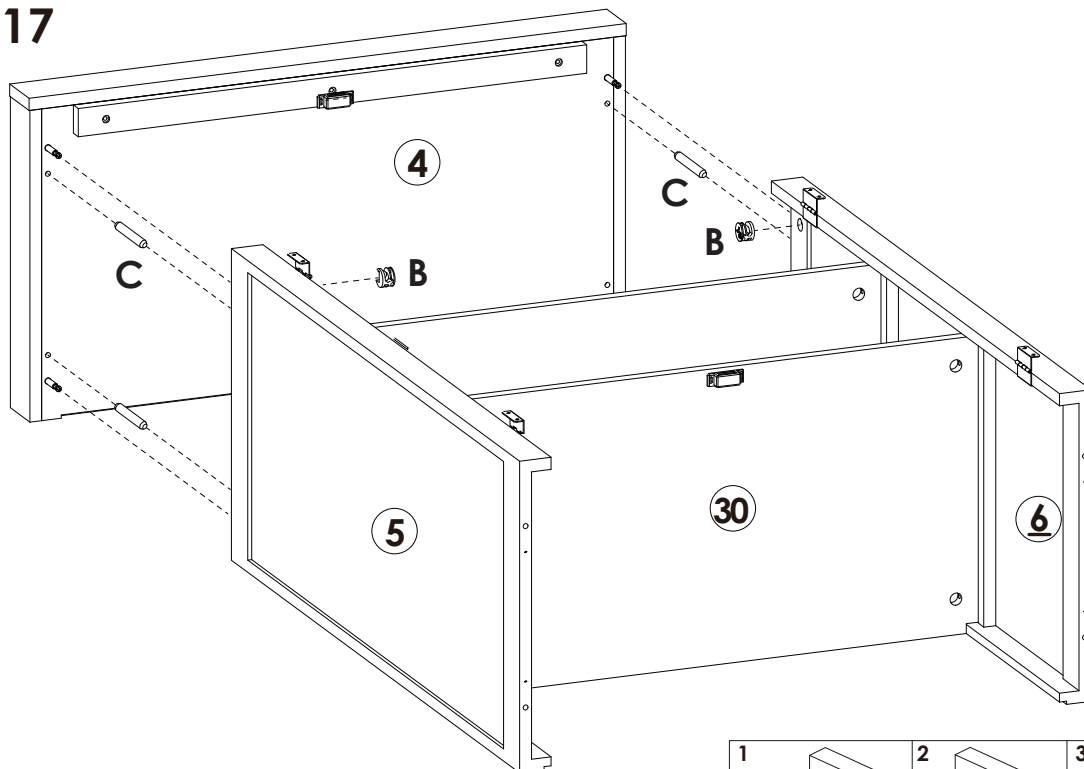

## STEP 17

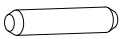

	<b>B x 4PCS</b>
	<b>C x 4PCS</b>

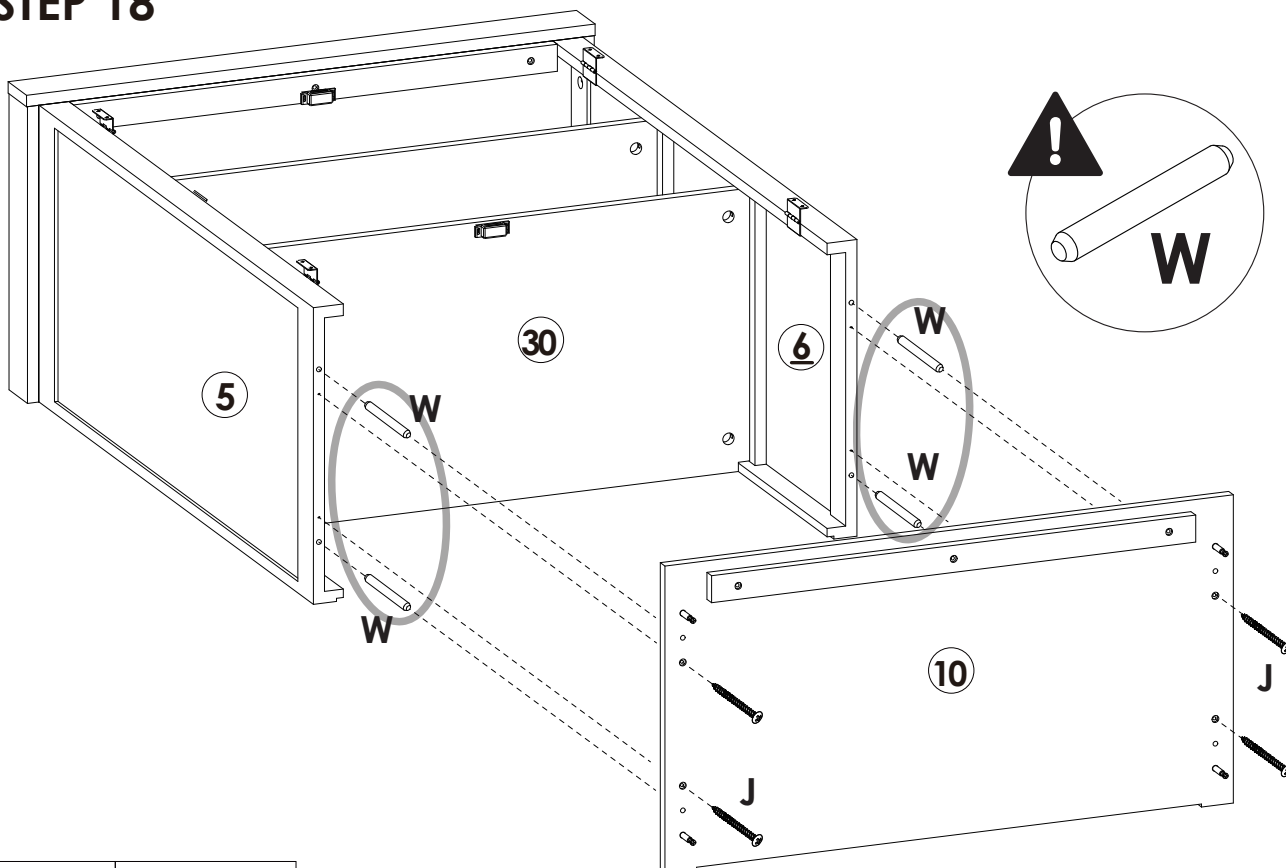
## STEP 18

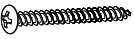

	<b>J x 4PCS</b>
	<b>W x 4PCS</b>

# Assembly Steps(EN) / Montageschritte(DE)

## STEP 19

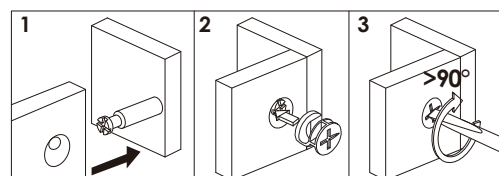
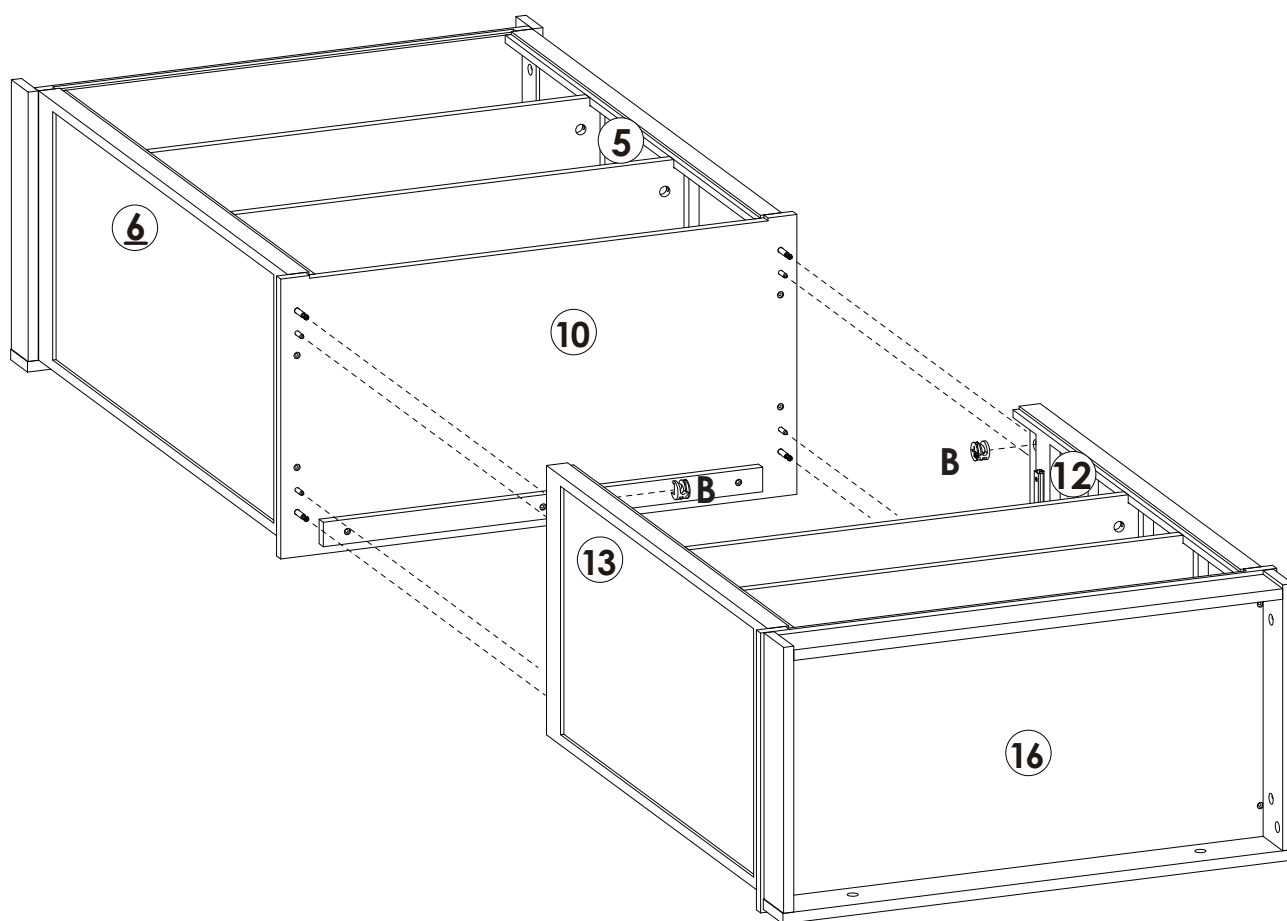



**B** x 4PCS

# Assembly Steps(EN) / Montageschritte(DE)

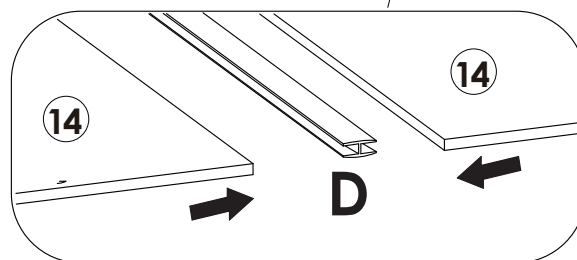
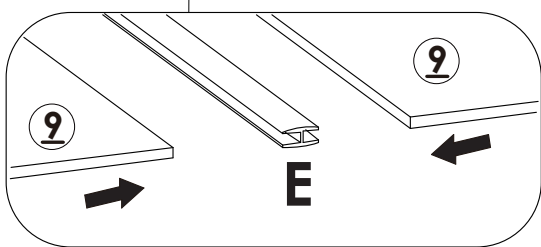
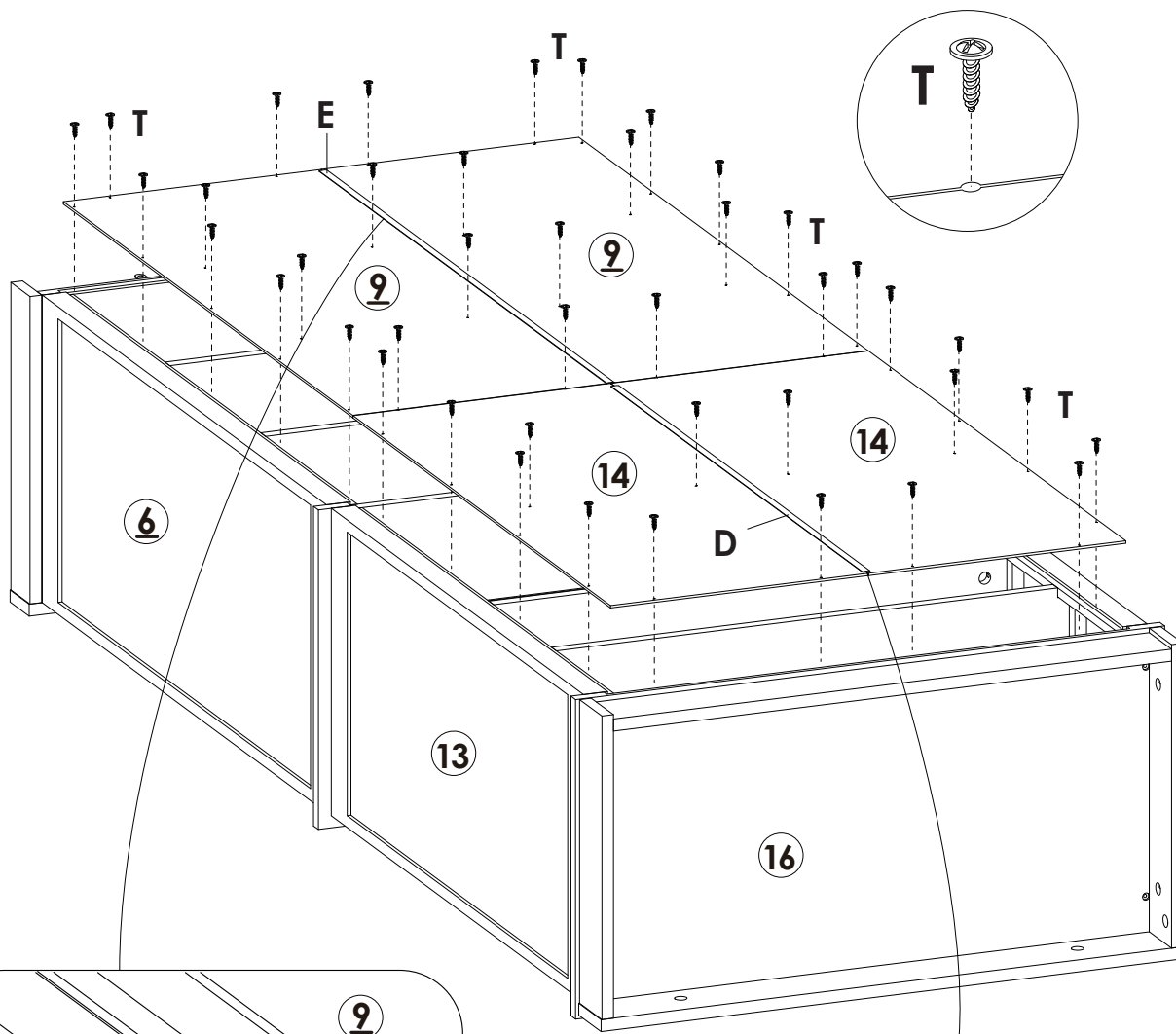
## STEP 20



	<b>D</b> x 1PC
	<b>E</b> x 1PC
	<b>T</b> x 42PCS

# Assembly Steps(EN) / Montageschritte(DE)

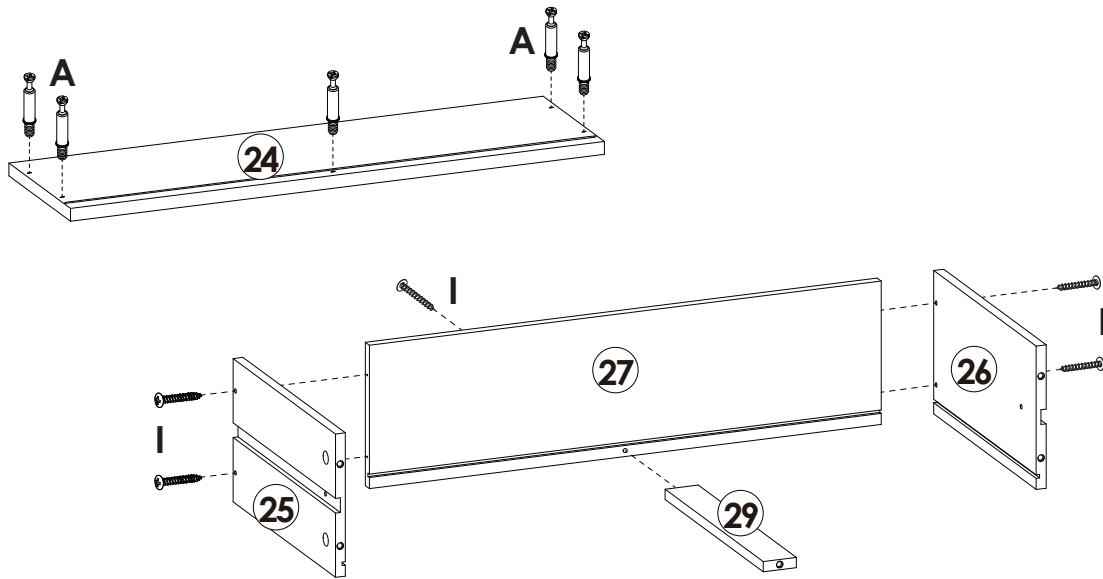

## STEP 21

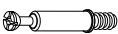
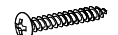

	A x 5PCS
	I x 5PCS

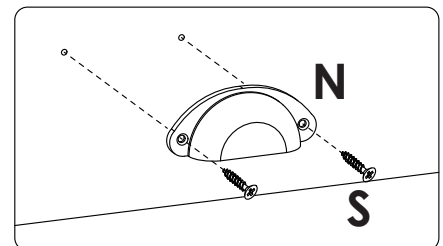
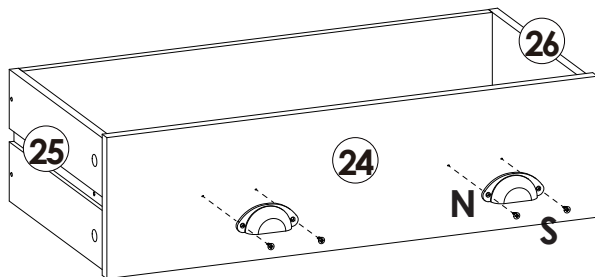
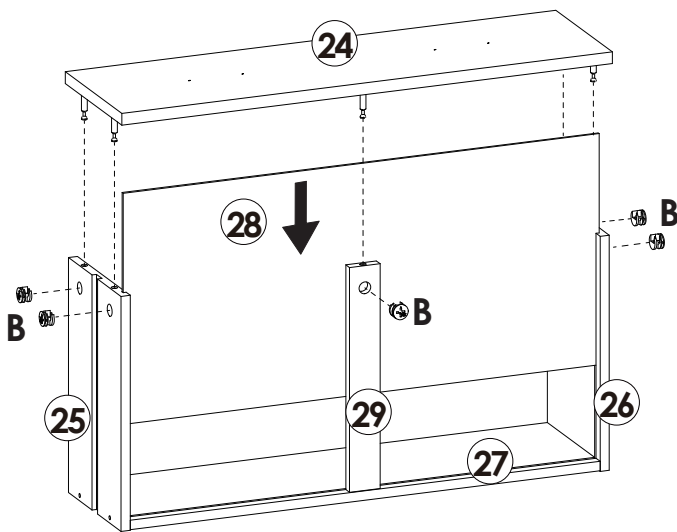
## STEP 22



	B x 5PCS
	N x 2PCS
	S x 4PCS

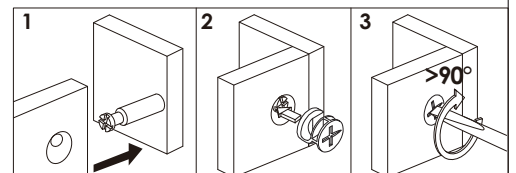

# Assembly Steps(EN) / Montageschritte(DE)

## STEP 23

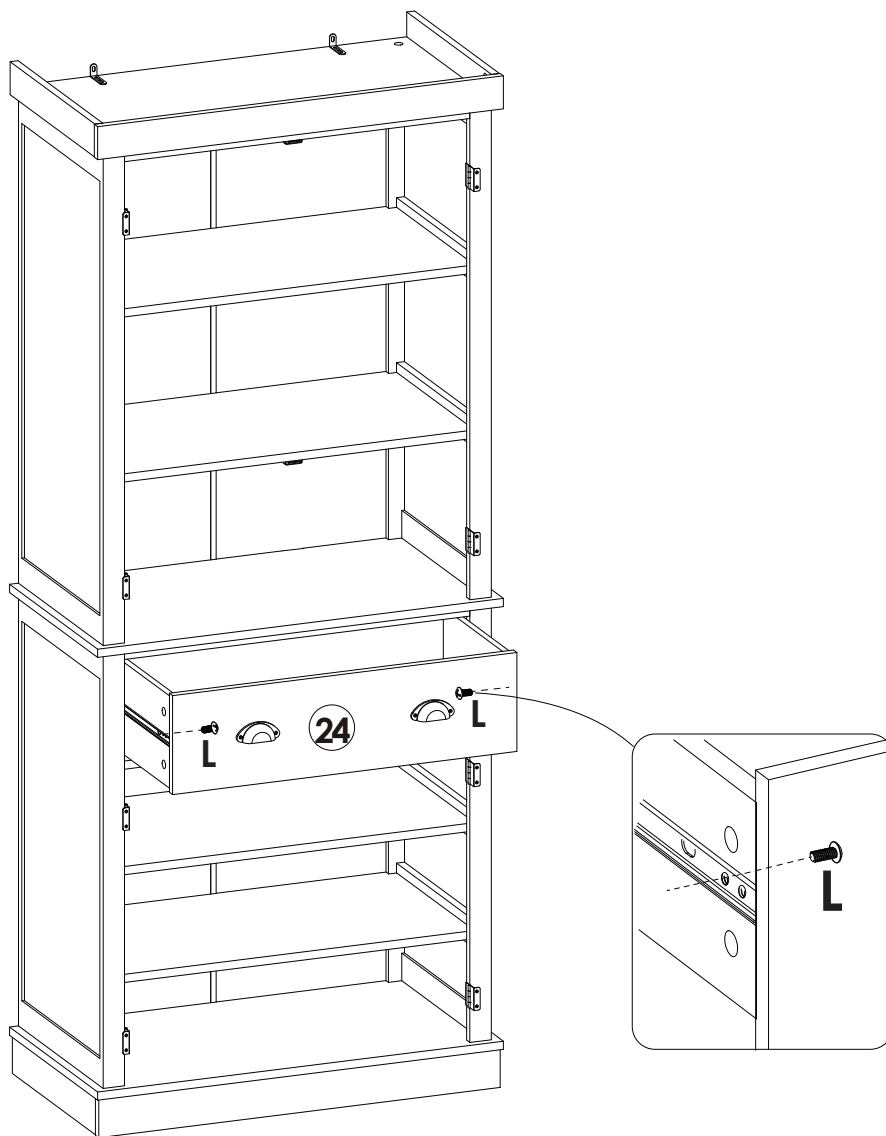

L x 2PCS

## STEP 24

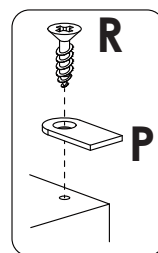
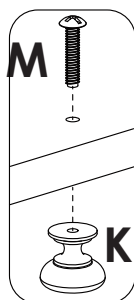
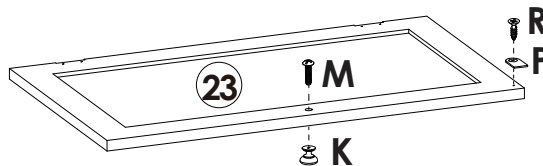
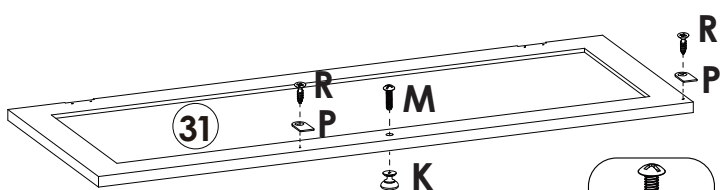
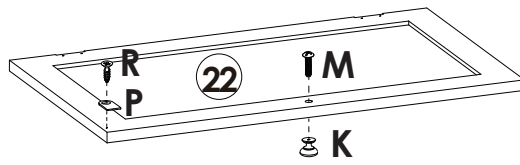
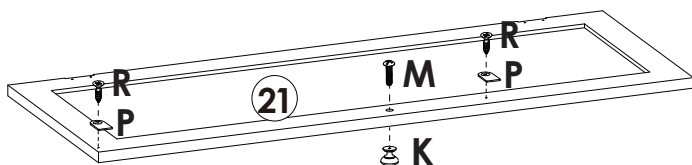

	K x 4PCS
	M x 4PCS
	P x 6PCS
	R x 6PCS

# Assembly Steps(EN) / Montageschritte(DE)

## STEP 25

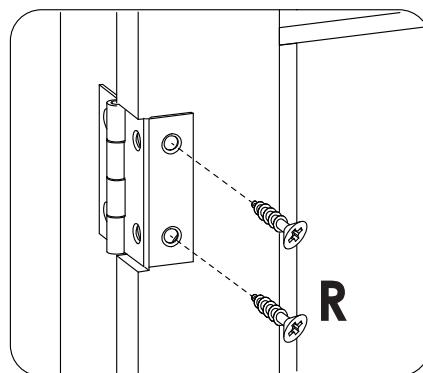
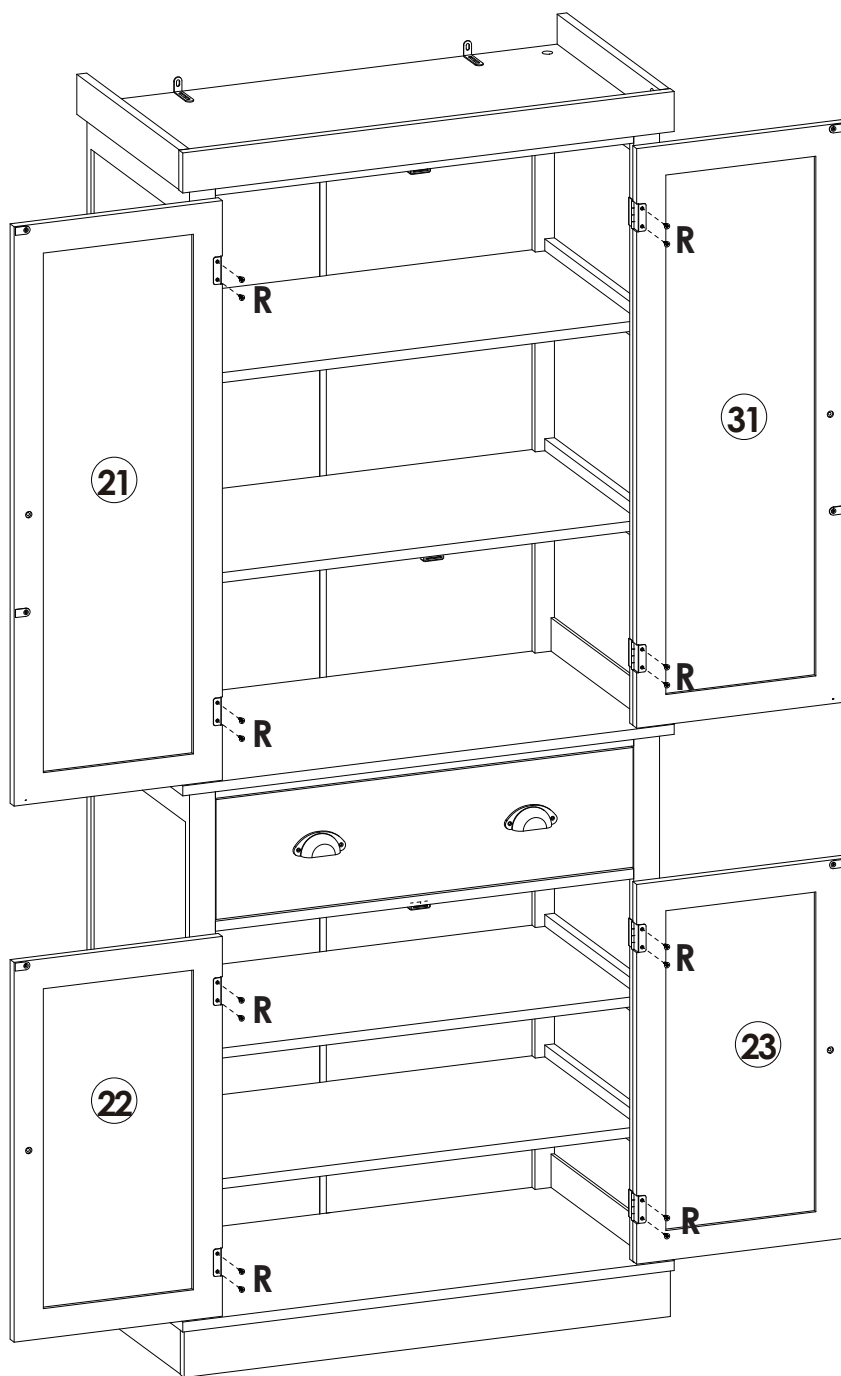

R x 16PCS

## Assembly Steps(EN) / Montageschritte(DE)

### STEP 26

Drill 2 holes on the wall at the required position for anti-falling device installation.

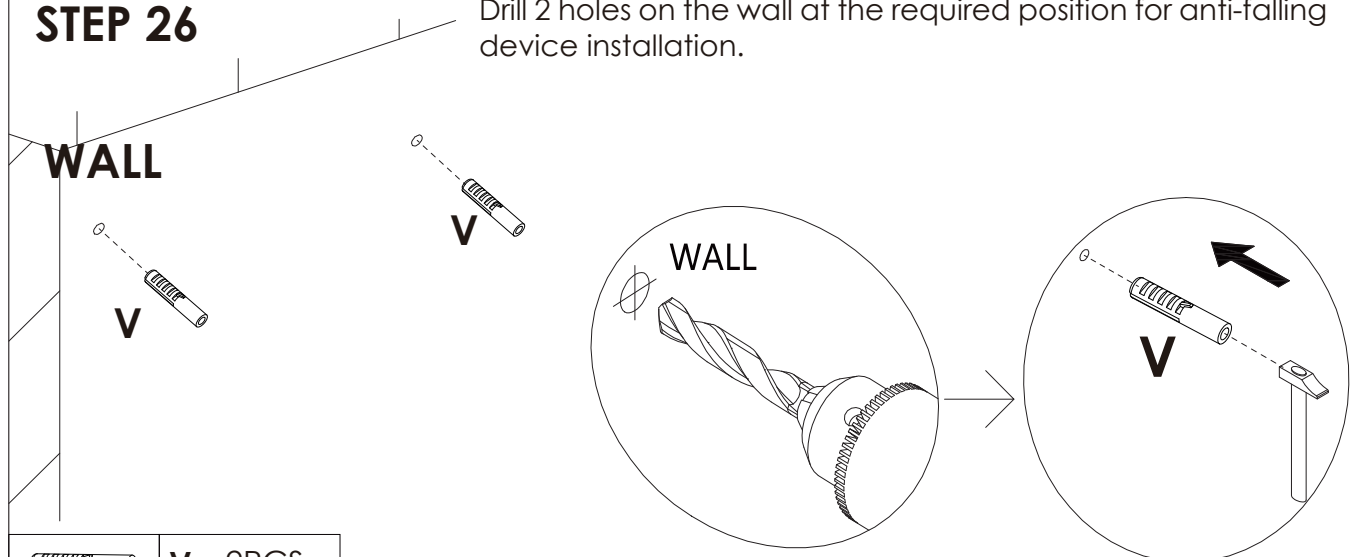

V x 2PCS

### STEP 27

Move the cabinet to the required position, use the "I" long screw to fix the cabinet to the wall.

WALL



I x 2PCS



## WARNING



Children have died from furniture tipover. To reduce the risk of furniture tipover:

- **ALWAYS** install Anti-tip device provided.
- **NEVER** put a TV on this product.
- **NEVER** allow children to stand, climb or hang on drawers, doors, or shelves.
- **NEVER** open more than one drawer at a time.
- Place heaviest items in the lowest drawers.

