

NOTICE

- * please make sure that you have all parts indicated and they are in good condition before you begin assembly of this item. Refer to part list and hardware list below for guidance.
- * This item should be assembled on a soft surface to prevent scratching the finish during assembly.
- * This item may require periodic tightening.
- * If you are having difficulty, our friendly Customer Care team is always here to help.







PREPARATION

- *Before beginning assembly of product, make sure all parts are present . Compare parts with package contents list and hardware contents list .
- *If any part is missing or damaged, do not attempt to assemble the product .
- *Estimated Assembly Time: **10 minutes** .
- *Tools Required for Assembly (included):**Allen Key**

CARE AND MAINTENANCE

Dust with a soft, dry cloth .Do not use abrasive cleaner . To clean glass, spray a small amount of glass cleaner onto a lint-free cloth and wipe glass clean .

Part List and Hardware List

Piece	Description	Picture	Quantity
A	Top Frame		1 X
B	Leg		2 X
C	Shelf		1 X
D	Top Glass		1 X
HW1	Allen Bolt (M6x1x10mm)		12 X
HW2	Glass Mat		4 X
HW3	Allen Key		1 X

Product Dimensions: 22.1"Wx12.5"Dx24.5"H

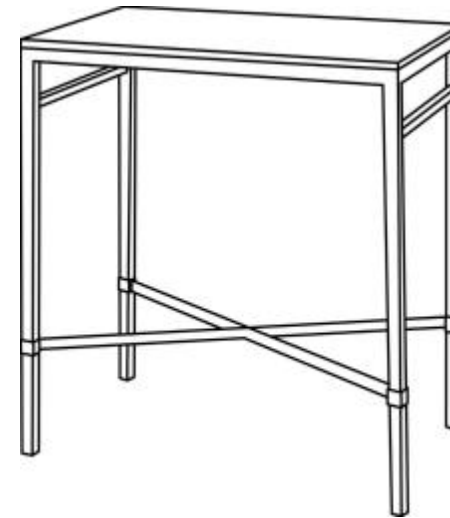

⚠ WARNING ⚠

Weight Capacity-30LBS
Warning:Do not stand on Table
Warning:Do not over torque bolts.

Preparation

- * Before beginning assembly of product, make sure all parts are present . Compare parts with package contents list and hardware contents list .
- * If any part is missing or damaged, do not attempt to assemble the product .
- * Estimated Assembly Time: 10 minutes .
- * Tools Required for Assembly (included): Allen Key
- * If you are having difficulty, our friendly Customer Care team is always here to help .

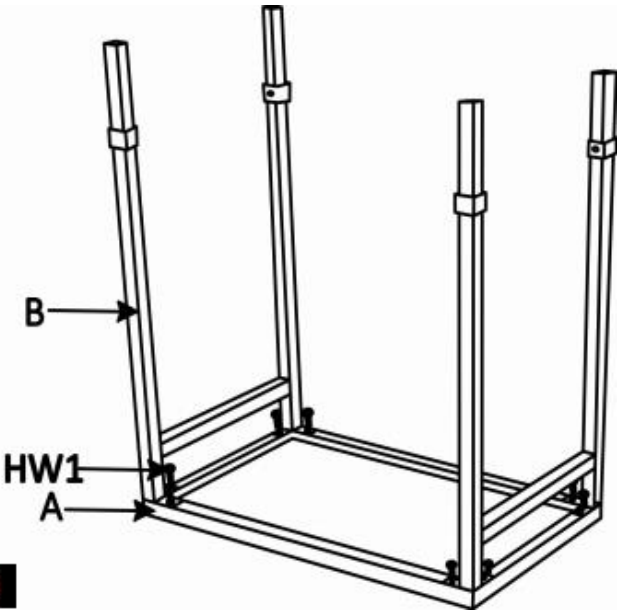
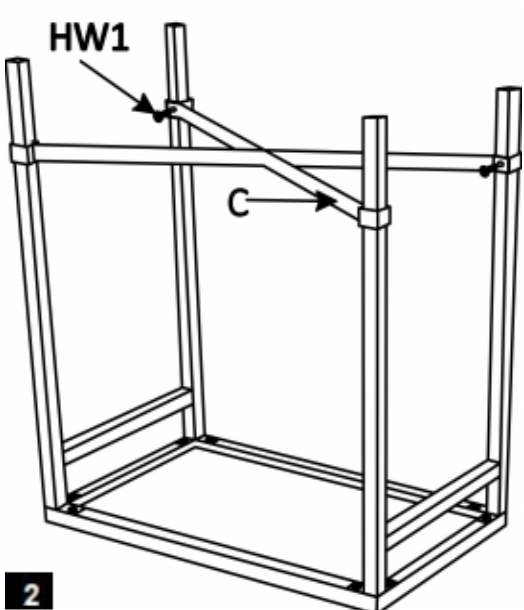
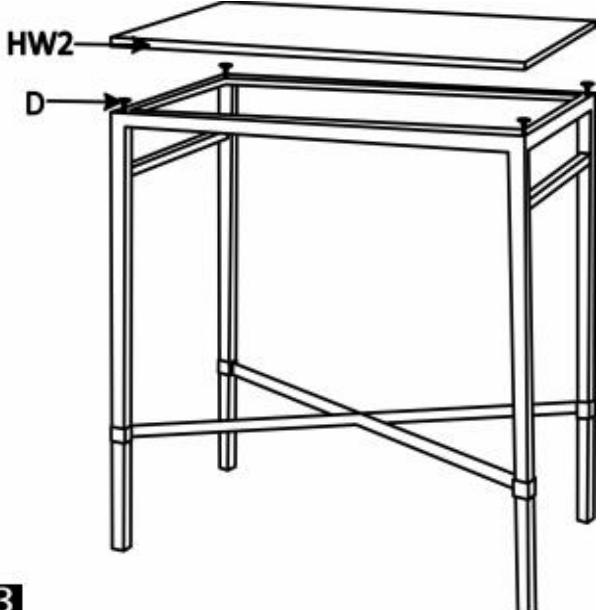
 <p>Diagram 1 shows the initial assembly of the table frame. A leg (B) is being attached to the top frame (A) using Allen bolts (HW1). The diagram is labeled with a '1' in a black box in the bottom left corner.</p>	 <p>Diagram 2 shows the next step where a shelf (C) is attached to the leg (B) using Allen bolts (HW1). The diagram is labeled with a '2' in a black box in the bottom left corner.</p>	 <p>Diagram 3 shows the final assembly step where glass mats (HW2) are placed on the frame and the glass (D) is placed on top. The diagram is labeled with a '3' in a black box in the bottom left corner.</p>
<p>STEP 1: Attach Leg (B) and Top Frame (A) together using Allen bolts(HW1). Do not fully tighten.</p>	<p>STEP 2: Attach Leg (B) and Shelf (C) together using Allen bolts (HW1). Now completely tighten all Allen Bolts.</p>	<p>STEP 3: Place the Glass Mats (HW2) on to the frame. Then place the glass (D) onto the Top (A).</p>