



SKU:KHD-UK-RF11

Lot NO: CY-NO.1

Assembly Guide

Tip!

Do check for all the components and screws listed in this guide before putting things together. If any part is missing, contact us at support@vecelo.com (US / CA) or support-euteam@vecelo.com (EU) for the missing part.

Return Policy

Your satisfaction is our top priority. If our product fails to satisfy you, please let us know how we can make things right for you. Our trained customer care team can handle most concerns and assist you with any questions you may have. Simply shoot them a message at support@vecelo.com(US/CA) or support-euteam@vecelo.com(EU) with your order number and question. To be eligible for a full-refund return, the item must be in pristine condition, in the original packaging, with all of the shipped components intact and not yet assembled, and with the item's unique proof of purchase.

Trouble shooting:

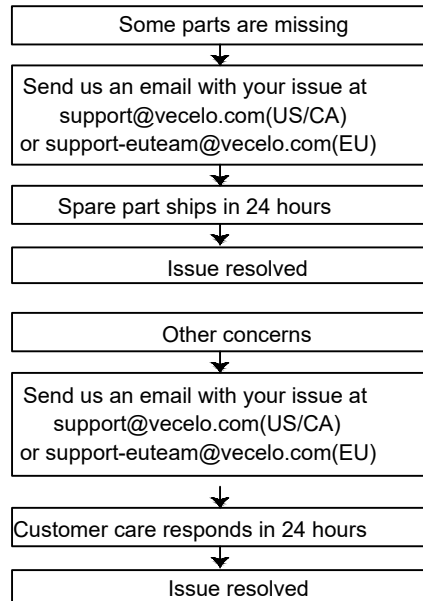

We run our own manufacturer, so rest assured about the quality consistency.

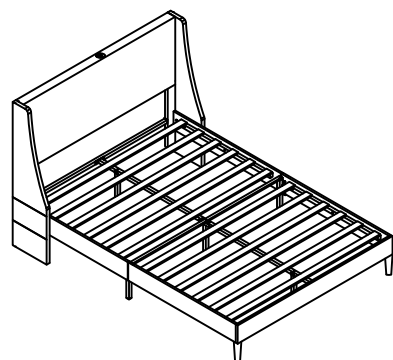

Item Description: Bed Frame

Model NO: CY-NO.1



SKU:KHD-UK-RF11

Lot NO: CY-NO.1

Montageanleitung

Tipp!

ÜBERPRÜFEN Sie alle in dieser Anleitung aufgeführten Komponenten und Schrauben, bevor Sie die Bauteile zusammenbauen. Sollte ein Bauteil fehlen, kontaktieren Sie uns unter support-euteam@vecelo.com um Ersatz zu erhalten.

Rückgabegerichtlinie

Ihre Zufriedenheit ist unsere oberste Priorität. Wenn Sie mit unserem Produkt nicht zufrieden sind, lassen Sie uns bitte wissen, wie wir die Angelegenheit für Sie in Ordnung bringen können. Unser geschultes Kundenbetreu kann die meisten Anliegen lösen und unter Sie bei allen Ihren Fragen. Senden Sie uns einfach eine Nachricht an support-euteam@vecelo.com mit Ihrer Bestellnummer und Ihrer Frage. Um eine volle Rückerstattung zu erhalten, muss der Artikel in einwandfreiem Zustand sein und sich in der Originalverpackung mit allen gelieferten und noch nicht zusammengebaute Komponenten befinden. Zudem wird der eindeutige Kaufnachweis des Artikels.

Problemlösung:

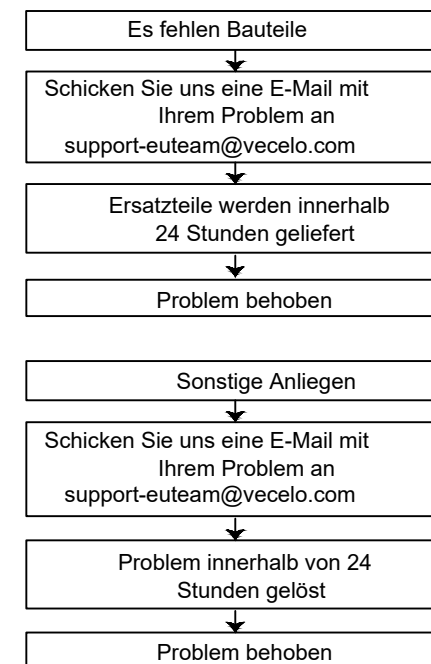

Wir stellen unsere Artikel selbst her, sodass Sie sich auf gleichbleibende Qualität verlassen können.

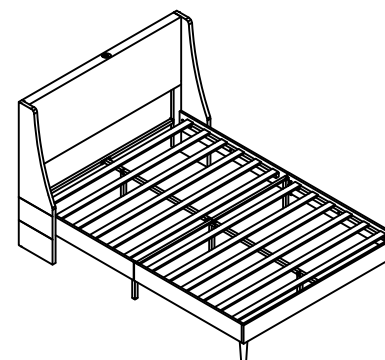

Item Description: Bettrahmen

Model NO: CY-NO.1



Guide de montage

Attention !

VÉRIFIEZ la présence de l'ensemble des éléments et vis énumérés dans ce guide avant de procéder au montage. Si une pièce venait à manquer, envoyez-nous un e-mail à support-euteam@vecelo.com pour nous le signaler.

Politique de retour

Votre satisfaction est notre priorité absolue. Si notre produit ne vous donne pas entière satisfaction, n'hésitez pas à nous faire savoir ce que nous pouvons faire pour améliorer la situation. Notre équipe d'assistance à la clientèle qualifiée est en mesure de résoudre la plupart de vos problèmes et de répondre à toutes vos questions. Il vous suffit de leur envoyer un message à l'adresse support-euteam@vecelo.com en indiquant votre numéro de commande et votre question. Pour pouvoir bénéficier d'un remboursement intégral, l'article doit être en parfait état, dans son emballage d'origine, avec tous les composants expédiés intacts et non encore assemblés, et avec la preuve d'achat unique de l'article.

SKU:KHD-UK-RF11

Lot NO: CY-NO.1

Dépannage :

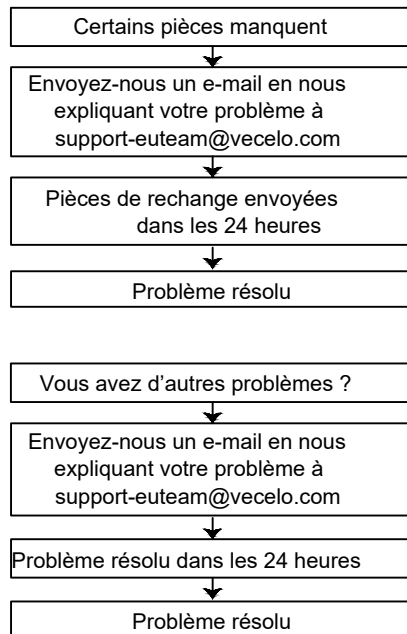

Nous assurons notre propre fabrication, donc soyez assuré de bénéficier d'une qualité constante.

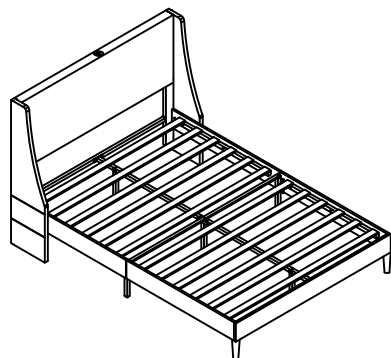

Item Description: Cadre de lit

Model NO: CY-NO.1



Guida all'assemblaggio

Mancia!

Controllare tutti i componenti e le viti elencati in questa guida prima di inserire le cose insieme. Se manca qualche parte, contattaci a support-euteam@vecelo.com per i dispersi parte.

Politica di ritorno

La vostra soddisfazione è la nostra massima priorità. Se il nostro il prodotto non ti soddisfa, faccelo sapere come possiamo sistemare le cose per te. Nostro un team di assistenza clienti qualificato può gestire la maggior parte preoccupazioni e assistervi per qualsiasi domanda tu forse hai. Invia loro semplicemente un messaggio a support-euteam@vecelo.com con il tuo numero d'ordine e domanda. Essere eleggibile per un reso con rimborso completo, l'articolo deve essere presente ottime condizioni, nella confezione originale, con tutti i componenti spediti intatti e non ancora assemblato e con l'oggetto unico prova d'acquisto.

SKU:KHD-UK-RF11

Lot NO: CY-NO.1

Risoluzione dei problemi:

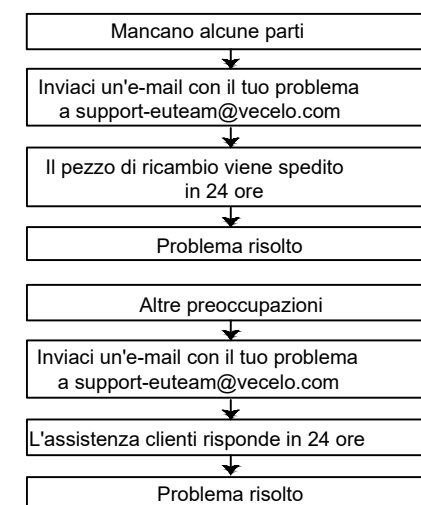

Gestiamo il nostro produttore, quindi riposati assicurato circa la consistenza di qualità.

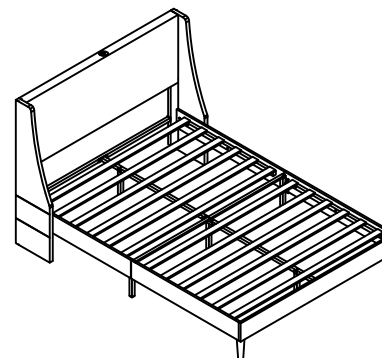

Descrizione dell'articolo: Telaio del letto

Model NO: CY-NO.1



Guía de montaje

Consejo !

Verifique todos los componentes y tornillos. Enumerados en esta guía antes de poner las cosas juntos. Si falta alguna pieza, contáctanos al support-euteam@vecelo.com por los desaparecidos parte.

Política de devoluciones

Su satisfacción es nuestra máxima prioridad. Si nuestro el producto no le satisface, háganoslo saber. CÓMO podemos hacer las cosas bien para usted. Nuestro equipo de atención al cliente capacitado puede manejar la mayoría inquietudes y ayudarle con cualquier pregunta es posible que tengas. Simplemente envíales un mensaje en support-euteam@vecelo.com con su número de pedido y pregunta. Ser elegible para una devolución con reembolso completo, el artículo debe estar en impecable estado, en el embalaje original, con todos los componentes enviados intactos y aún no ensamblado y con la característica única del artículo. Comprobante de compra.

SKU:KHD-UK-RF11

Lot NO: CY-NO.1

Solución de problemas:

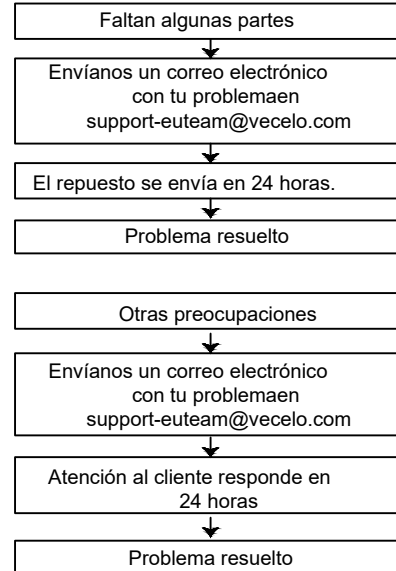

Dirigimos nuestro propio fabricante, así que descansa. Asegurado sobre la consistencia de la calidad

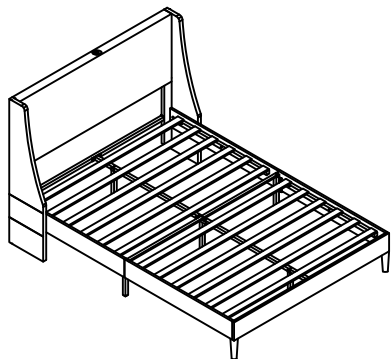

Descripción del artículo: Marco de la cama

Model NO: CY-NO.1

CAUTION!



ACHTUNG!



ATTENTION !



CAUTELA !



PRECAUCIÓN !



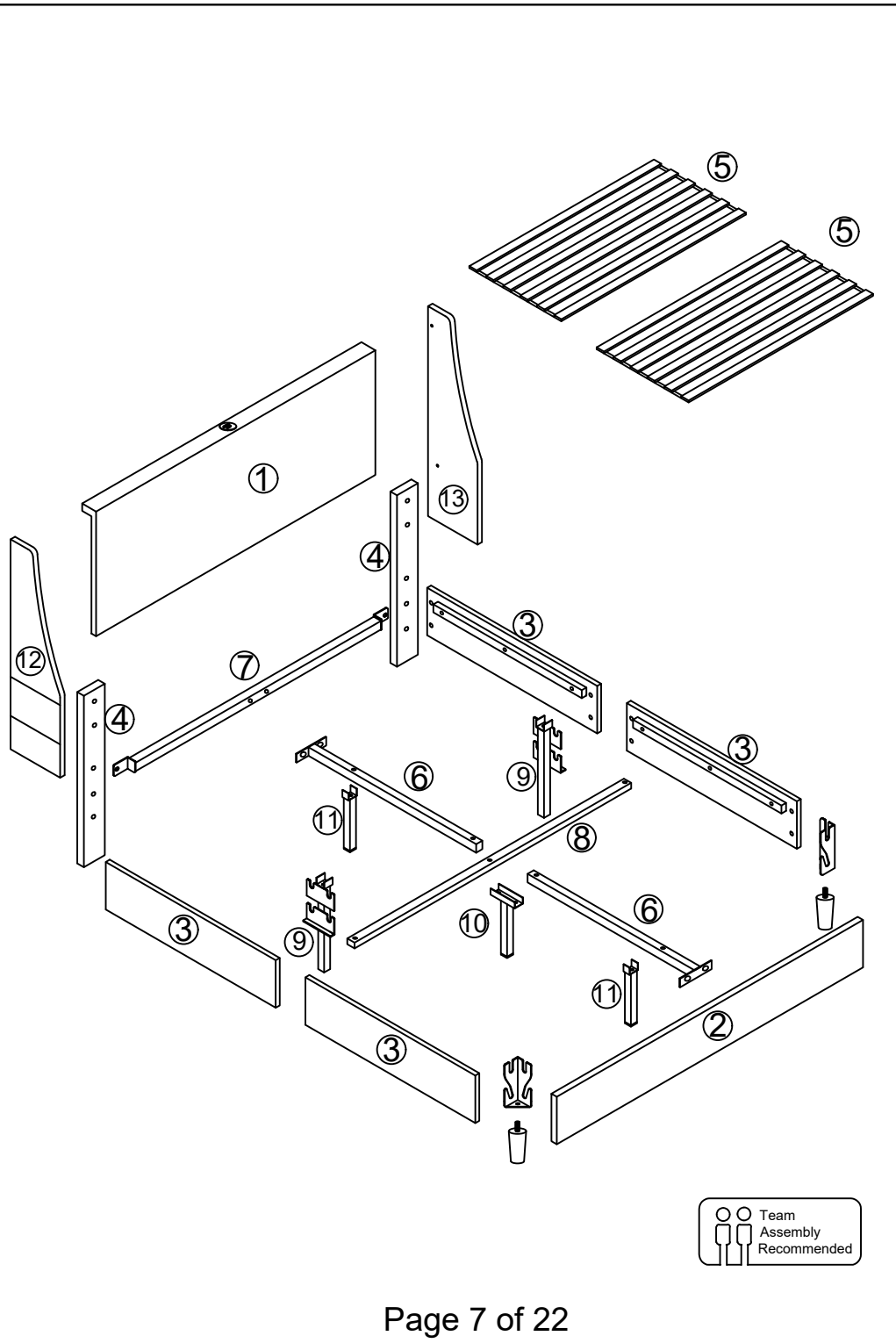







Parts List

①		1pcs	②		1pcs
③		4pcs	④		2pcs
⑤		2pcs	⑥		2pcs
⑦		1pcs	⑧		1pcs
⑨		2pcs	⑩		1pcs
⑪		2pcs	⑫		1pcs
⑬		1pcs			







Hardware List

(A)		4	(B)		16
(C)		4	(D)		5
(E)		4	(F)		

Preinstilled on components

(A-1)	 Bolt M8 x 16 Preinstilled on components	20			
-------	---	----	--	--	--

Hardware List

(G)		2	(H)		1
(I)		1	(J)		4
(K)		2	(L)		1

Step 1

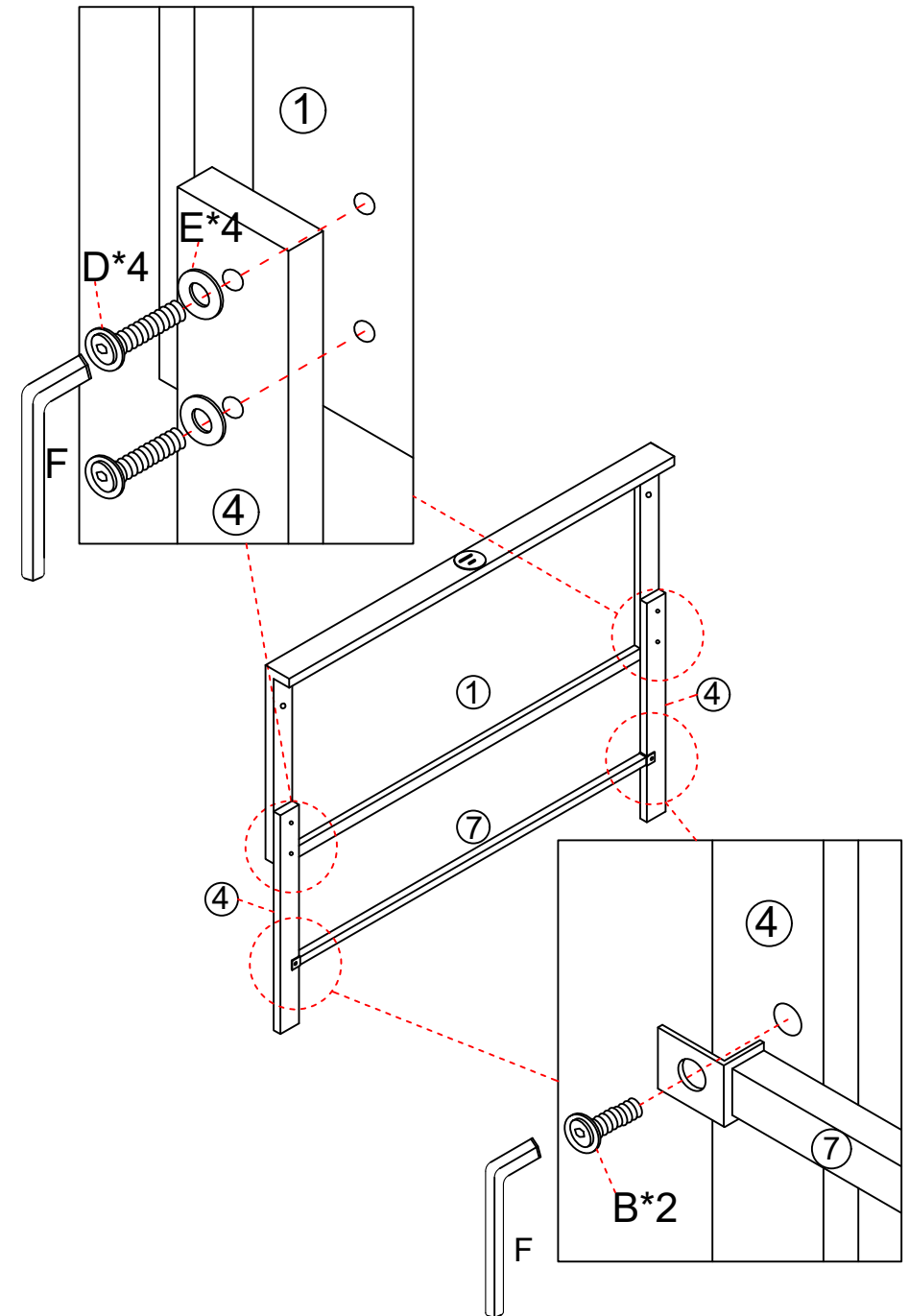

Step 2



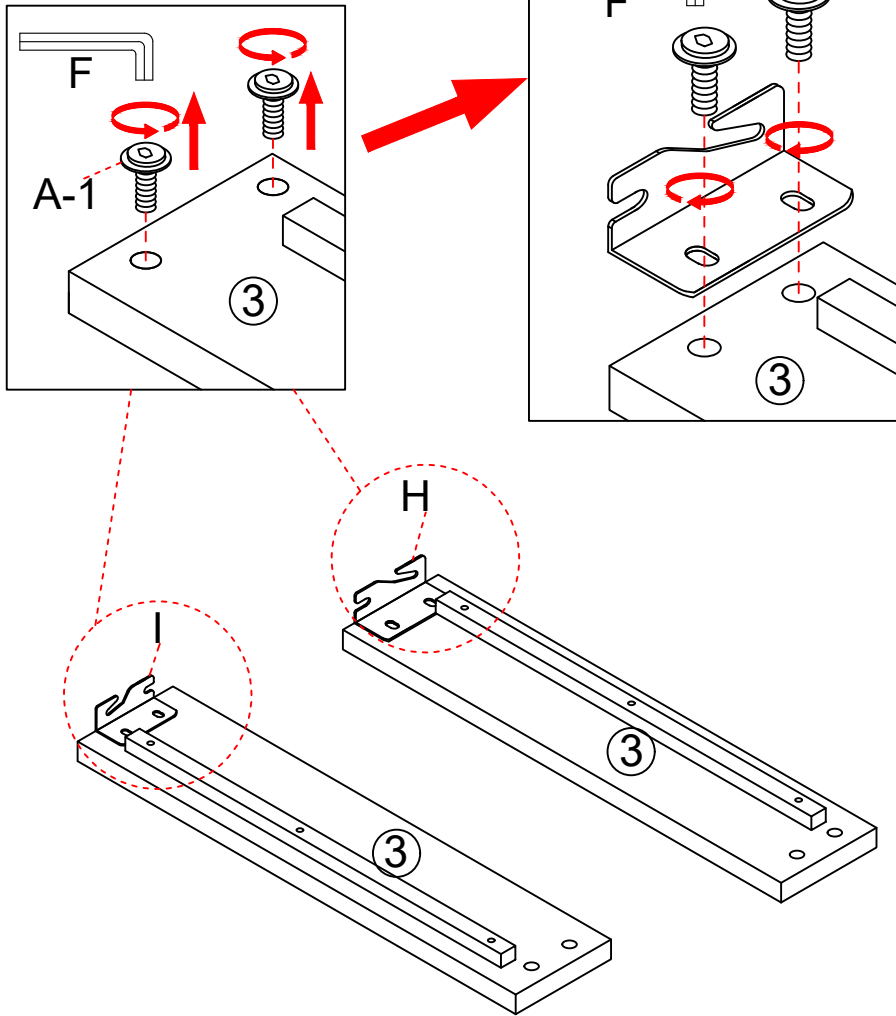

Tips:
Must Keep the Brackets
Lay Toward the Ground

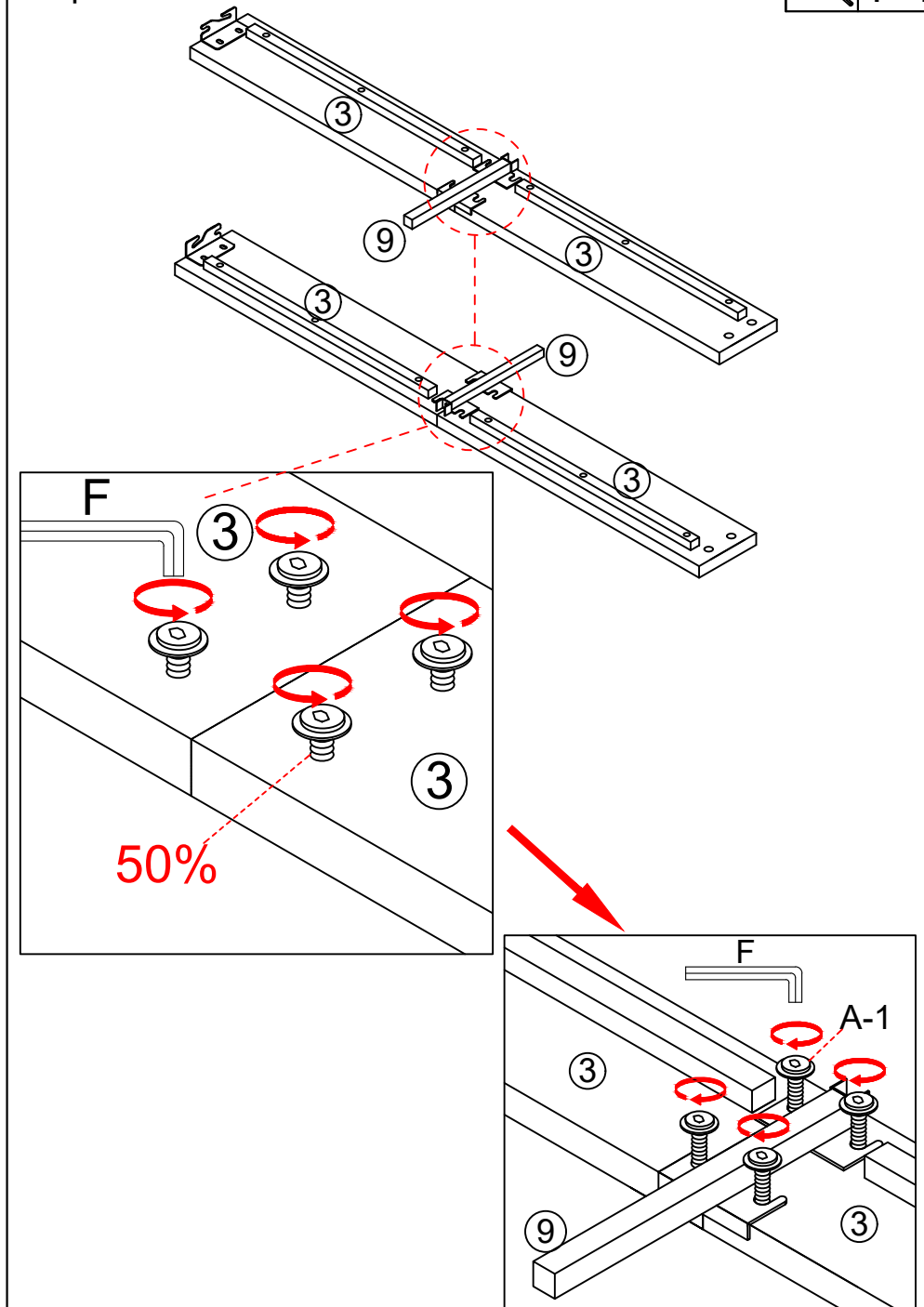

Step 3



Step 4

 G*2  K*2

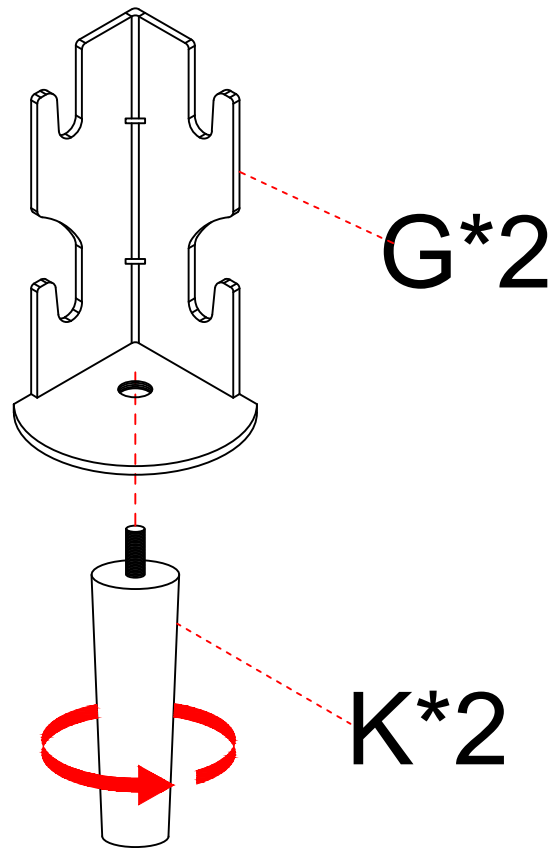

Step 5

 B*4  F*1

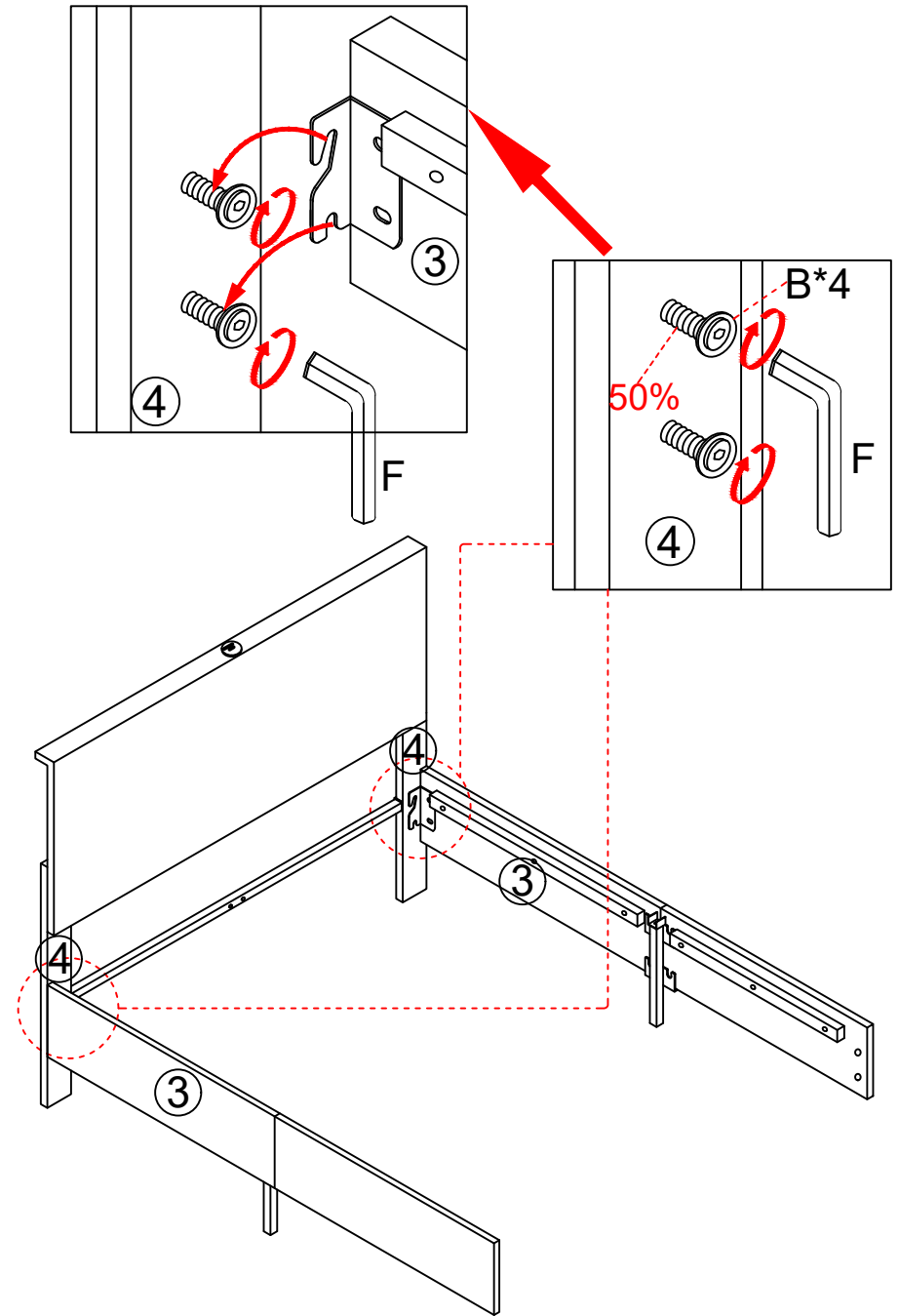

Step 6



- Loose the Preinstalled 4 Screws for leg Installation, and Then Tighten Them Again
- ★ Desserrez les 4 vis préinstallées pour le pied Installation, puis resserrez-les.
- ▲ Lösen Sie die Originalschraube, installieren Sie das Bein, und ziehen Sie die Originalschraube.
- Allentare le 4 viti Preinstallate per l'installazione della gamba, quindi serrarle nuovamente.
- ⚙️ Afloje los 4 tornillos Preinstalados para la instalación de las patas y luego apriételes nuevamente.

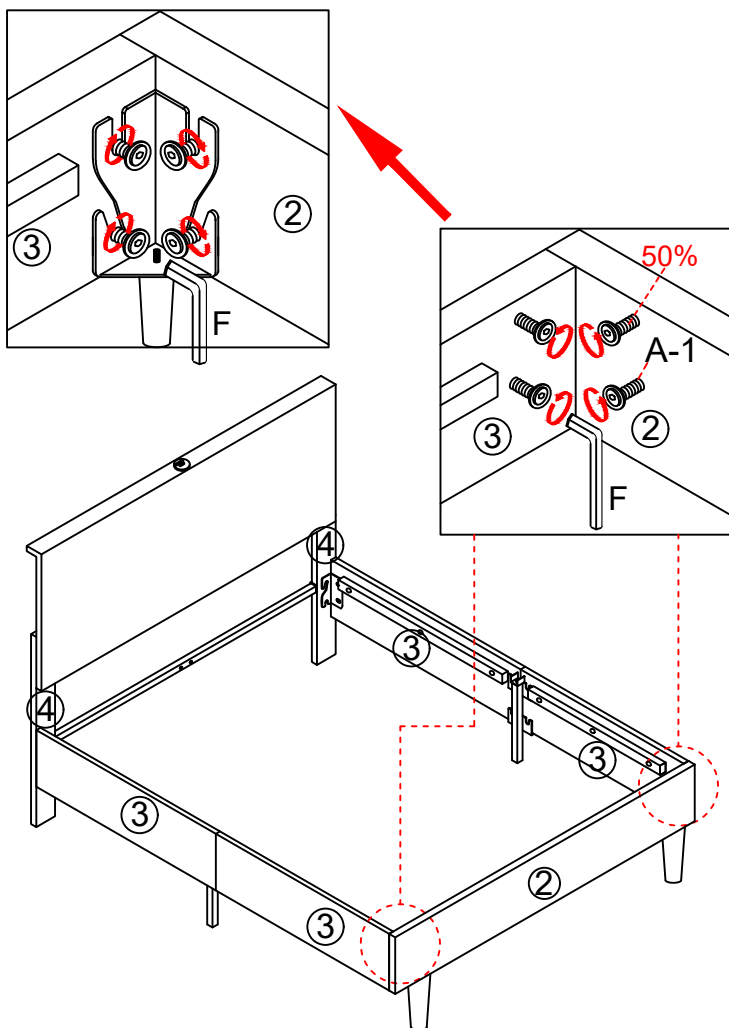

Step 7

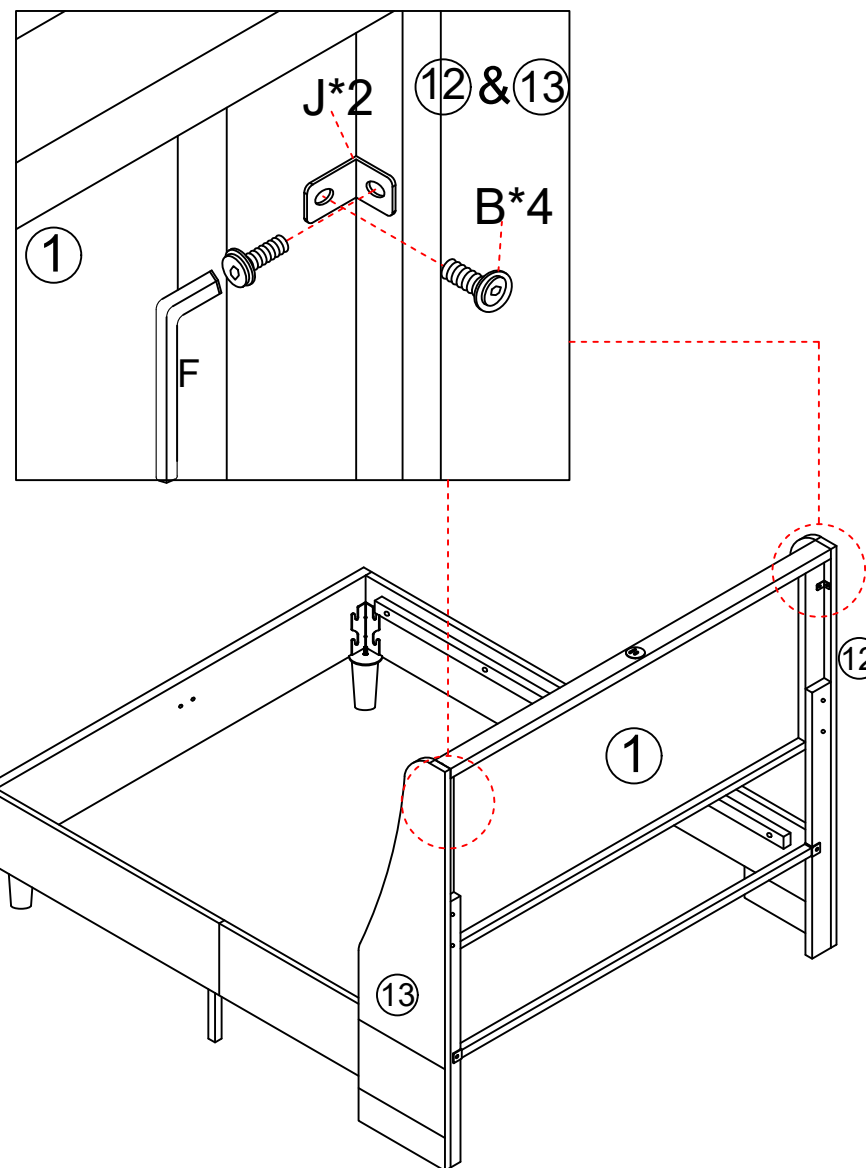

Step 8

J*2 B*4 F*1

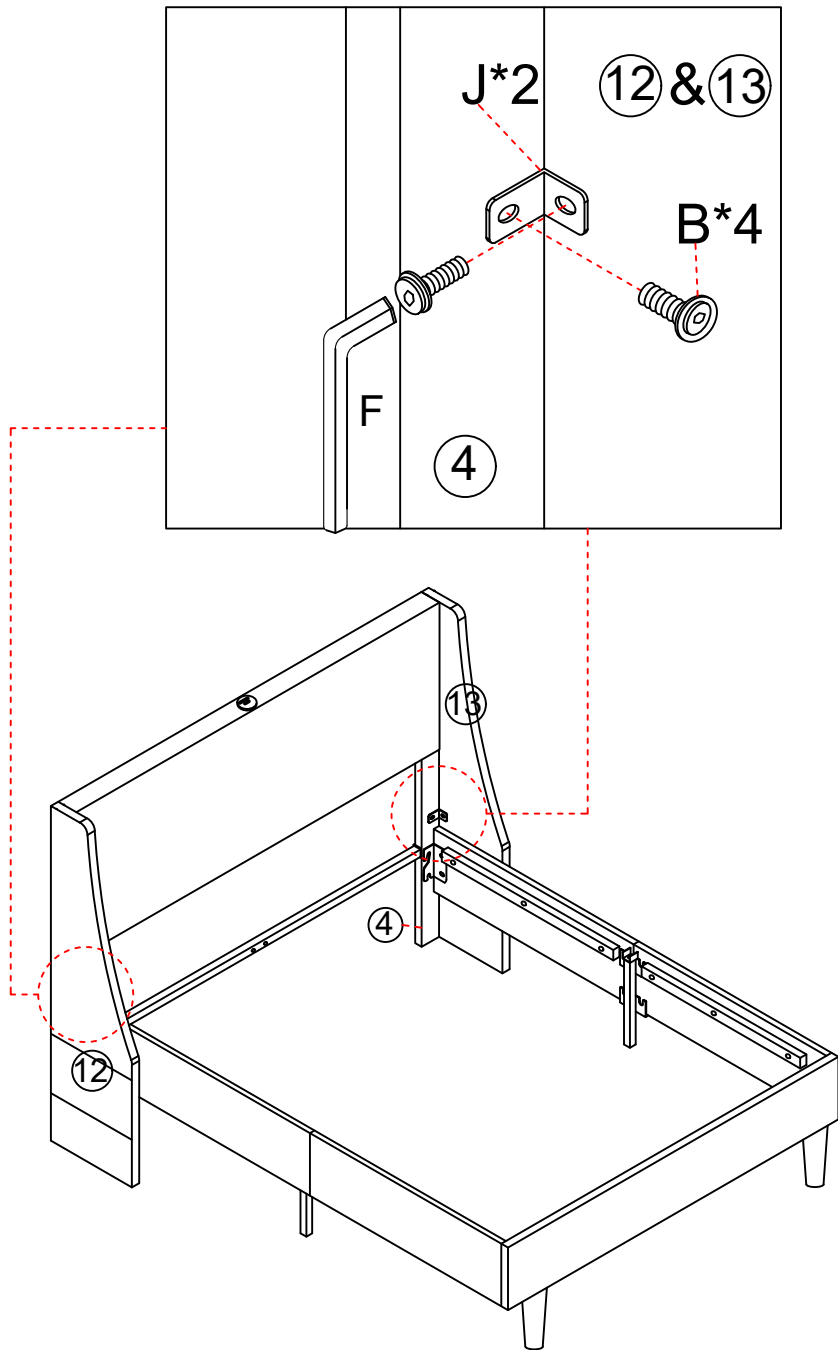

Step 9

B*2 C*2 F*1

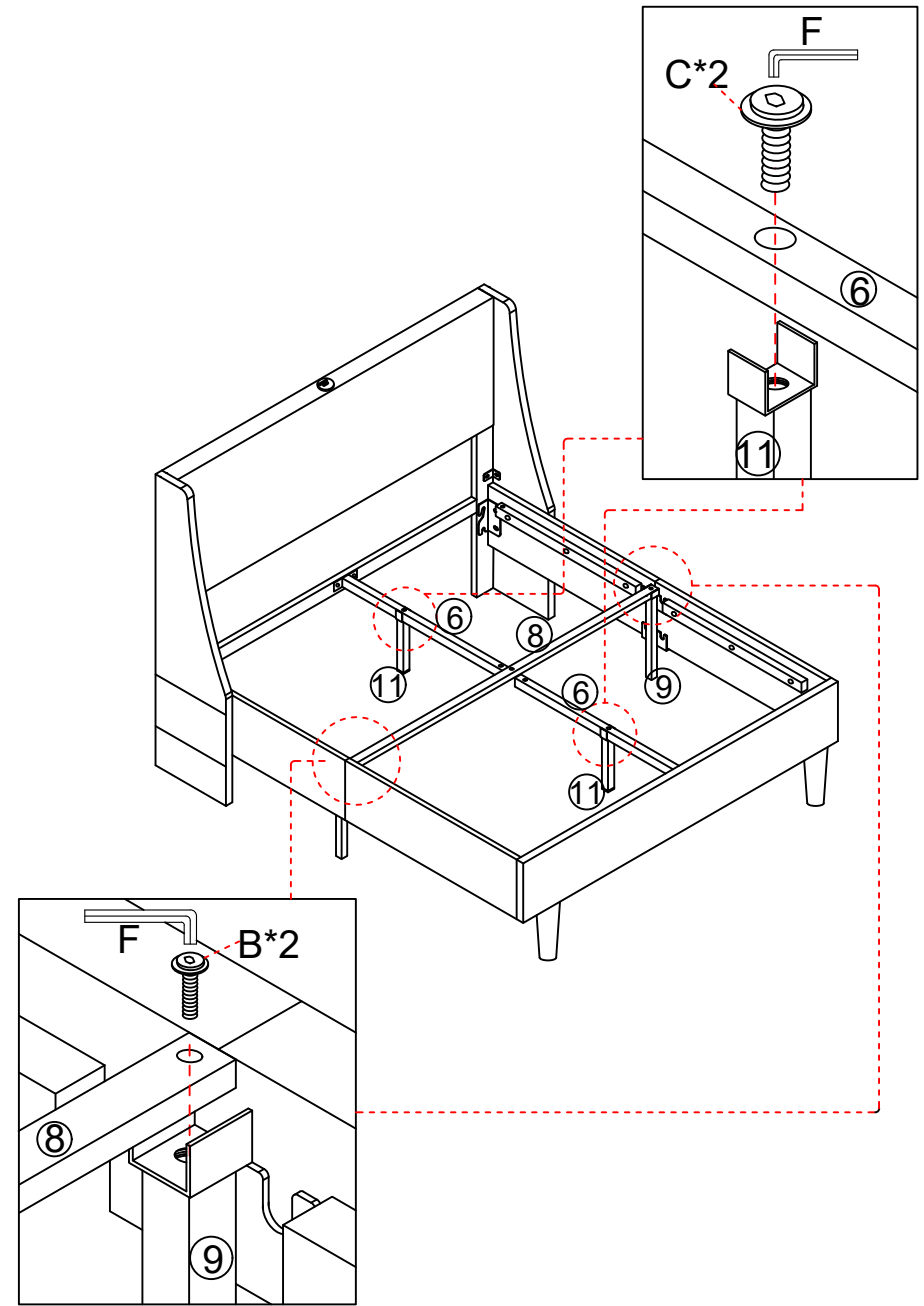

Step 10

A*4
 C*2
 D*1
 F*1

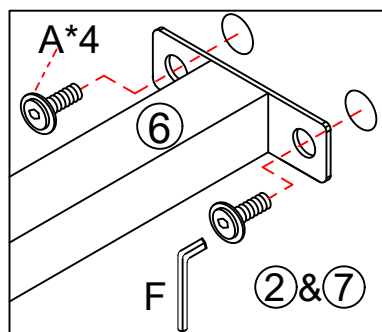

- Unscrew the original screw
- ★ Dévisser la vis d'origine
- ▲ Lösen Sie die Originalschraube
- Svitare la vite originale
- Desenrosque el tornillo original

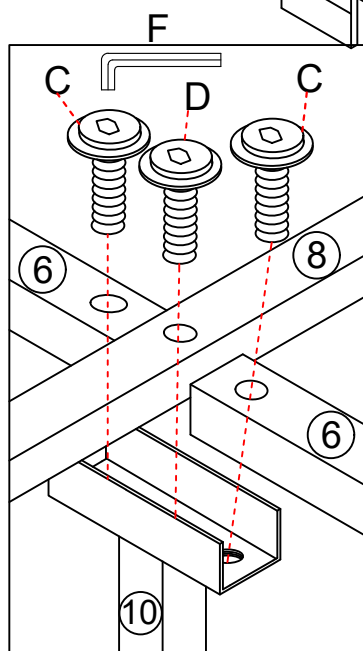
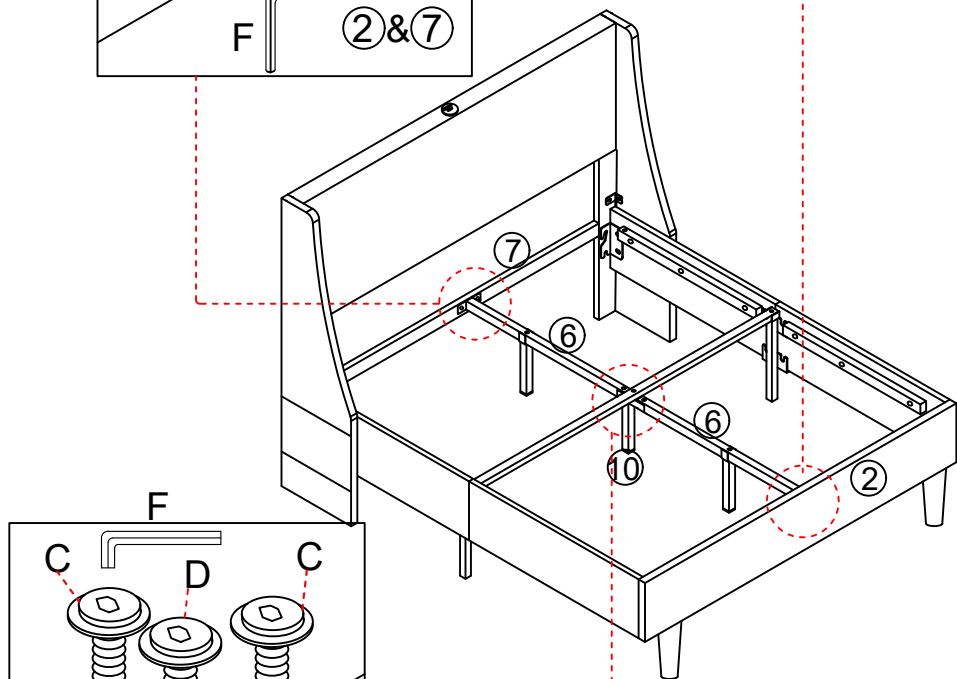

- Tighten the original screw
- ★ Serrer la vis d'origine
- ▲ Ziehen Sie die Originalschraube
- Stringere la vite originale
- Apretar el tornillo original

Step 11

L*1

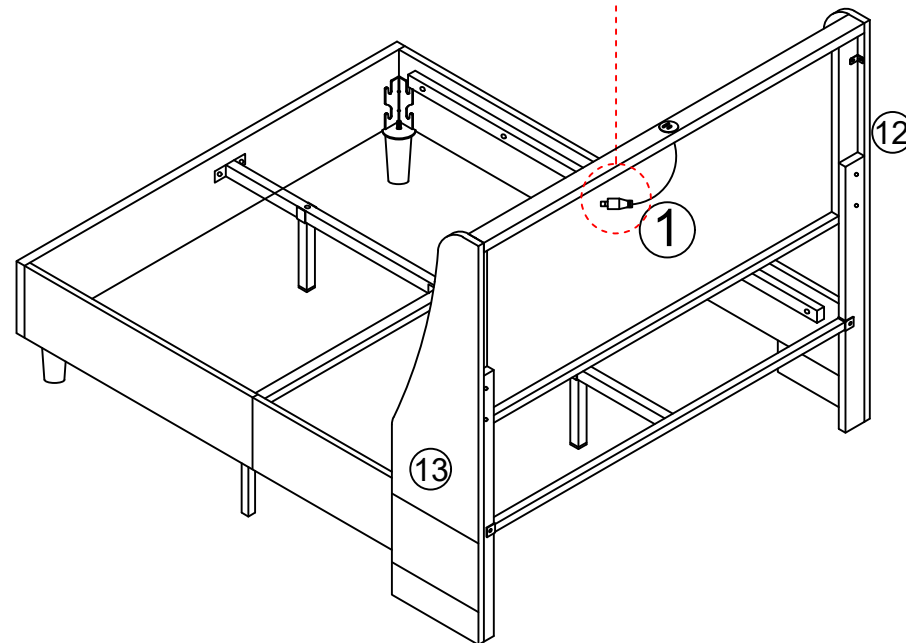
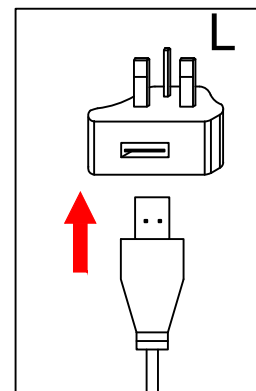

Step 12

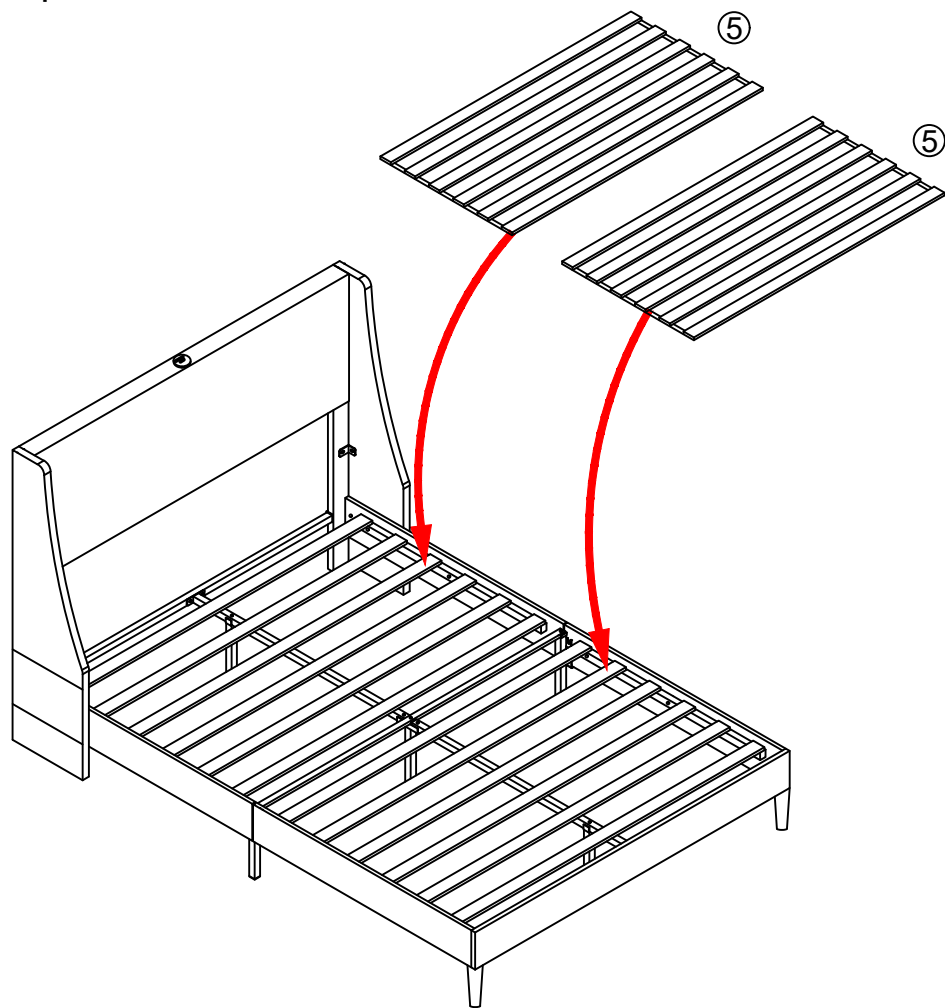

- Note: Now remember to double check all screws are properly fastened.
- ★ Hinweis: Vergessen Sie jetzt nicht, zu überprüfen, ob alle Schrauben richtig angezogen sind.
- ▲ Remarque : N'oubliez pas de vérifier que toutes les vis sont bien serrées.
- Nota: Ora ricordati di ricontrollare che tutte le viti siano correttamente fissate.
- ✿ Nota: Ahora recuerde volver a verificar que todos los tornillos estén correctamente apretados.

Step 13

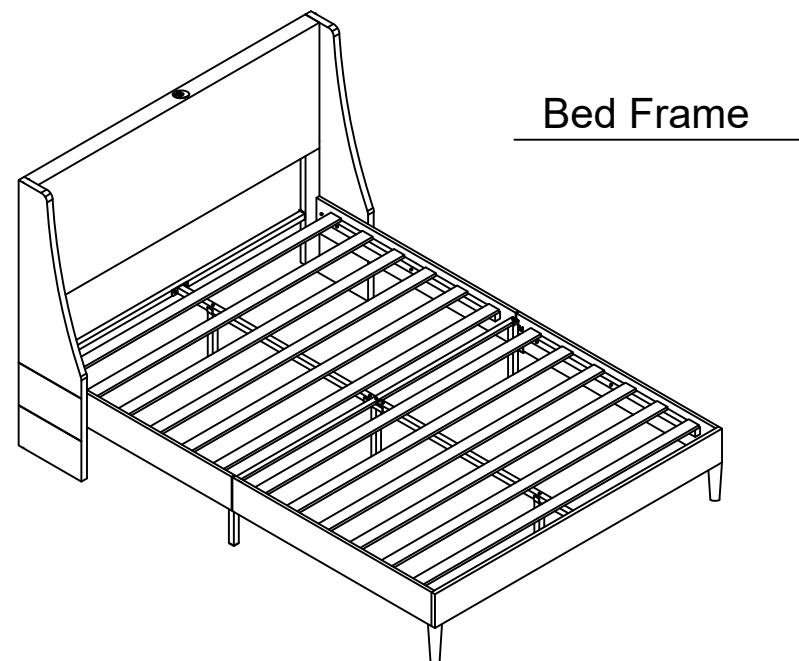

CONTACT US
KONTAKTIEREN SIE UNS
NOUS CONTACTER
CONTATTACI
CONTACTENOS



Tel : +1 (570) 530-2113

E-mail: support@vecelo.com(US/CA)

E-mail: support-euteam@vecelo.com(EU/FR/DE/ES/IT)

Website: www.vecelo.com