

Assembly Instructions

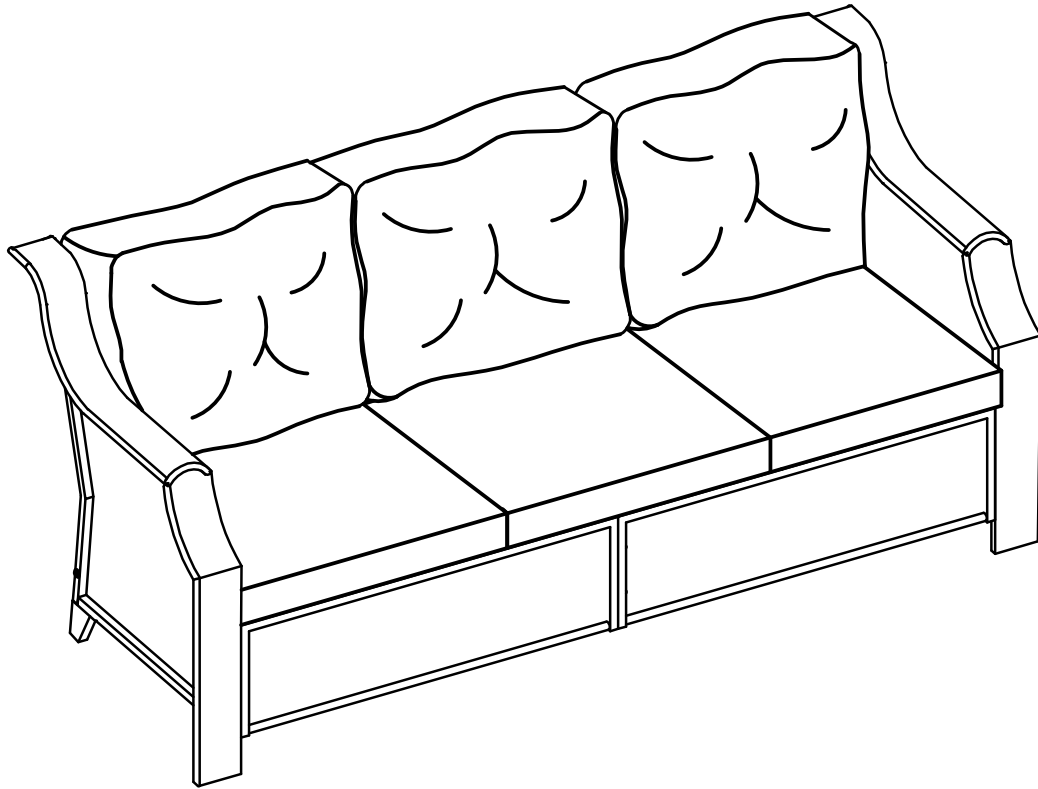

For any missing hardware, damaged parts and other problems.
WELCOME to email us at: service@behousewell.com

Or call at 1-888-733-8169 Toll free
Between 9AM and 5PM Eastern time, Monday through Friday

***Don't fully tighten all the bolts till the very end!**

PRE-ASSEMBLY PREPARATION:

- A cordless drill is recommended for ease of assembly.
- Clear out the space for assembly and lay out all of the parts based on the Parts List, extra room will allow you to easily determine if all the pieces are present.
- Keep small parts and pieces away from children until fully assembled.



A1

Left
Arm
1pc

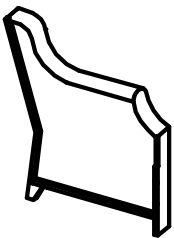

C

Back
1pc

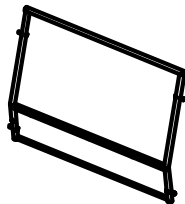

F

Support
Bar
1pc

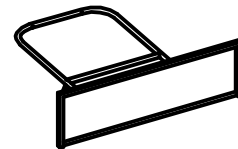

A2

Right
Arm
1pc

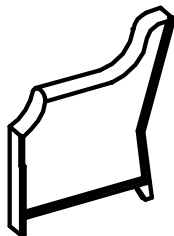

D

Seat
1pc

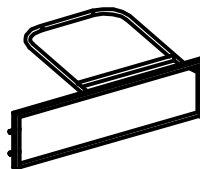

G

Support
Bar
1pc

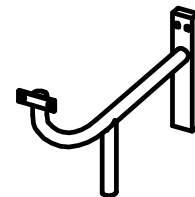

B

Back
1pc

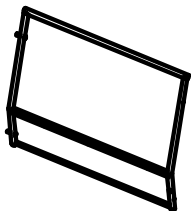

E

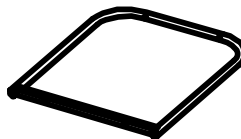

Seat
1pc

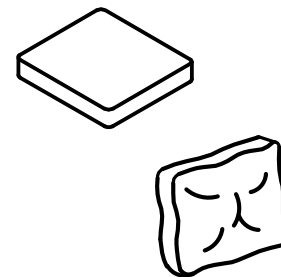

N+O

Seat
Cushion
Back
Cushion
3pcs

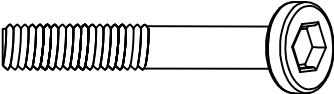
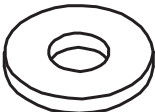
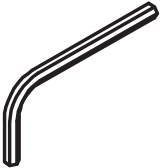

No.	Part/Size	QTY	Image	No.	Part/Size	QTY	Image
H	Bolt (M6*15mm)	6	**Actural Scale 	M	Washer	1	
I	Bolt (M6*20mm)	4	**Actural Scale 				
J	Bolt (M6*35mm)	14	**Actural Scale 				
K	Washer	24					
L	Allen Wrench	1					

Step 1: Attach left back B to right back C with 2pcs bolts I and 2pcs washers K , using Allen wrench L .Note:Don't fully tighten the bolts.

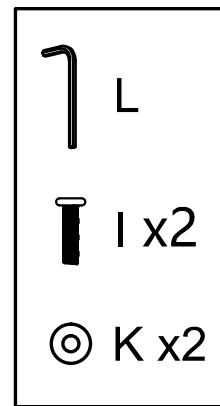
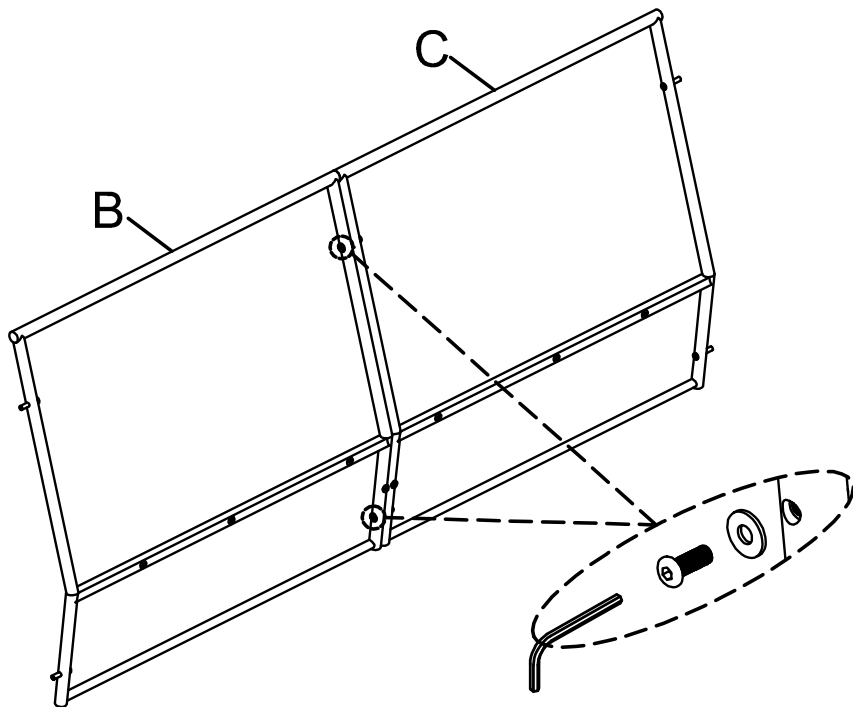

Step 2: Attach left seat F to right D with 2pcs bolts H and 2pcs washers K ,using Allen wrench L .Note: Don't fully tighten the bolts.

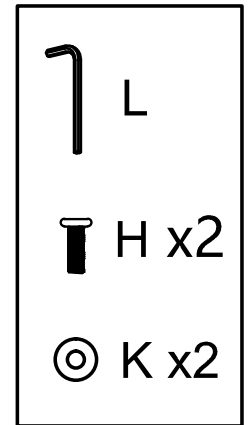
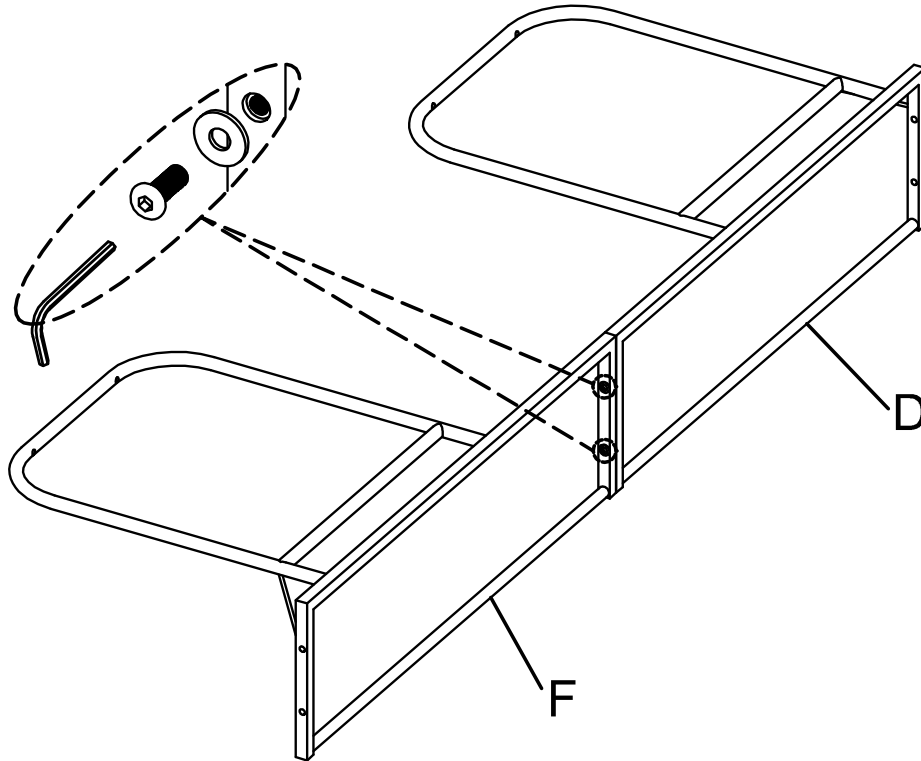

Step 3: Attach right A1 to back C with 2pcs bolts H and 2pcs washers K, using Allen wrench L. Note: Don't fully tighten all the bolts.

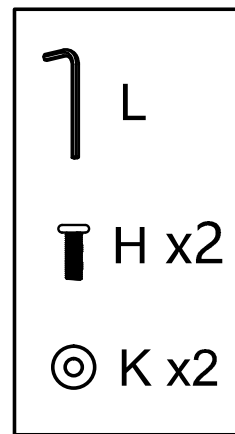
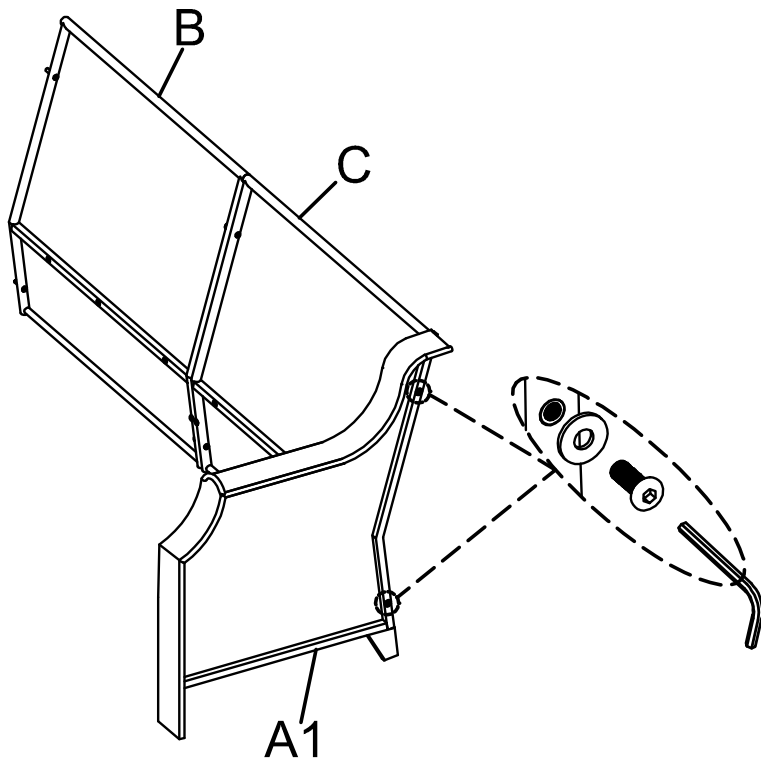

Step 4: Attach left arm A2 to back B with 2pcs bolts H and 2pcs washers K ,using Allen wrench L. Note:Don't fully tighten all the bolts.

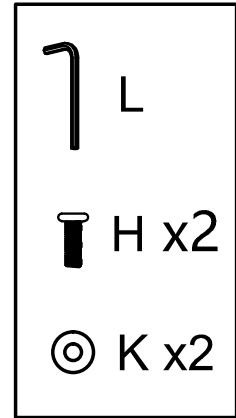
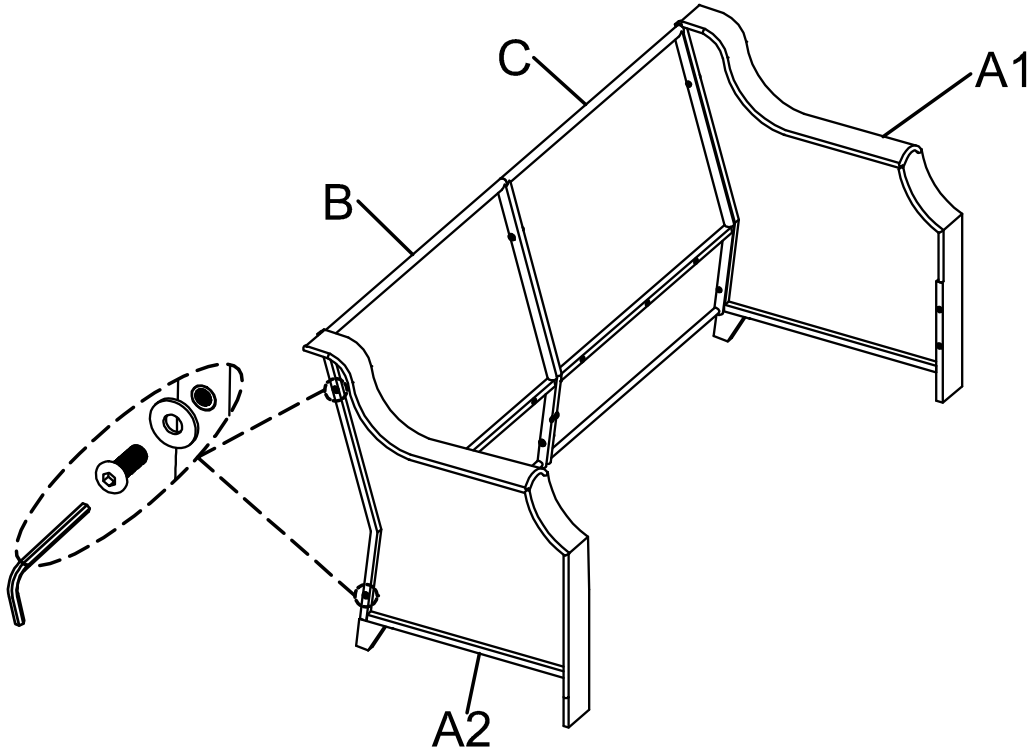

Step 5: Attach seat D&F to arms A1&A2 with 4pcs bolts J and 4pcs washer K, using Allen wrench L. Note: Don't fully tighten all the bolts.

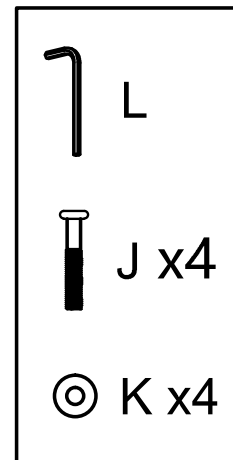
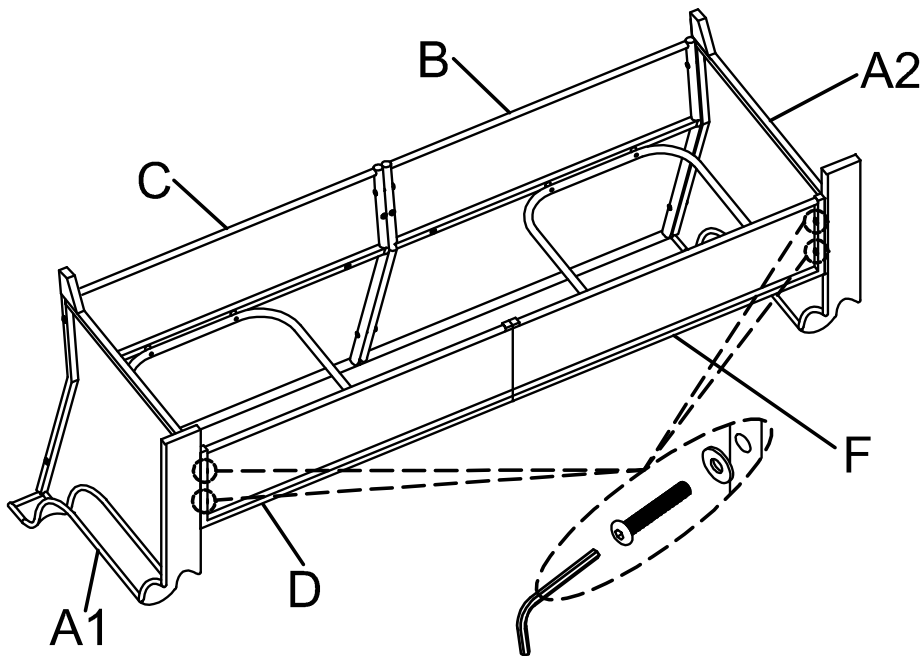

Step 6: Attach middle leg G to back with 2pcs bolt J, 1pc washer M and 2pcs washer K, using Allen wrench L.

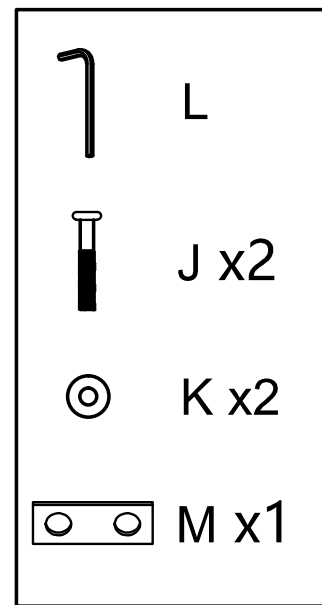
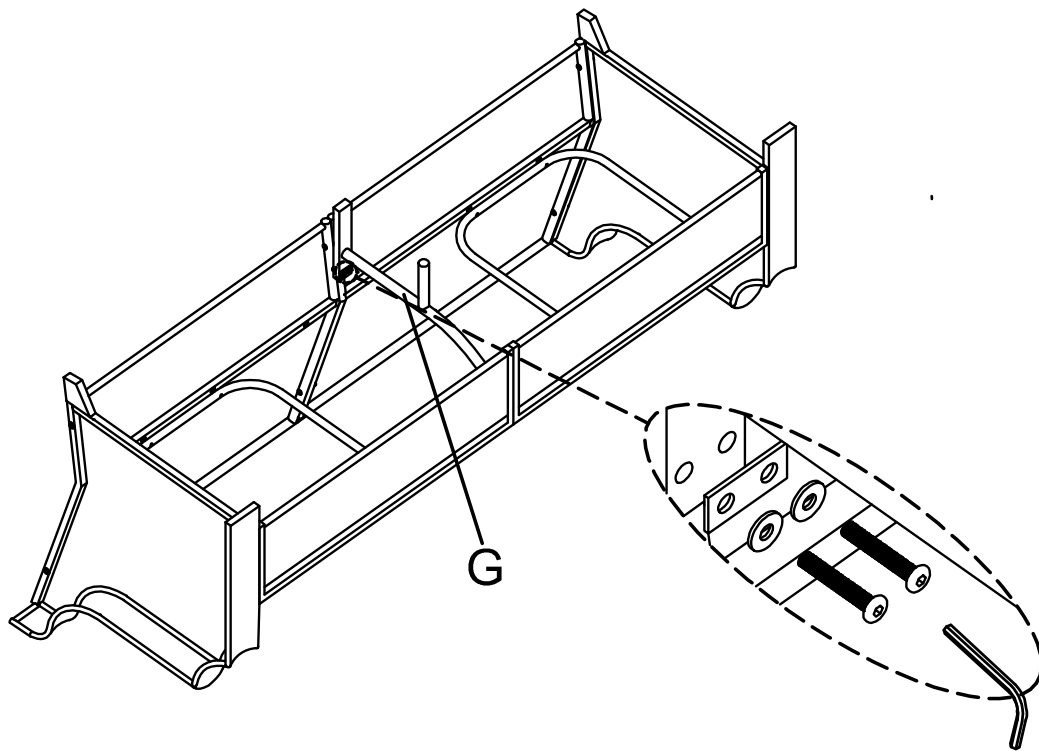

Step 7: Attach middle seat E to middle leg G with 2pcs bolts I and 2pcs washer K using Allen wrench L.

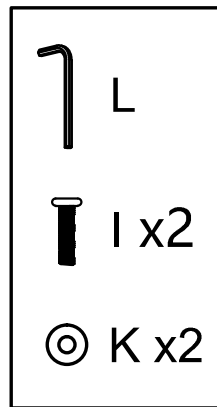
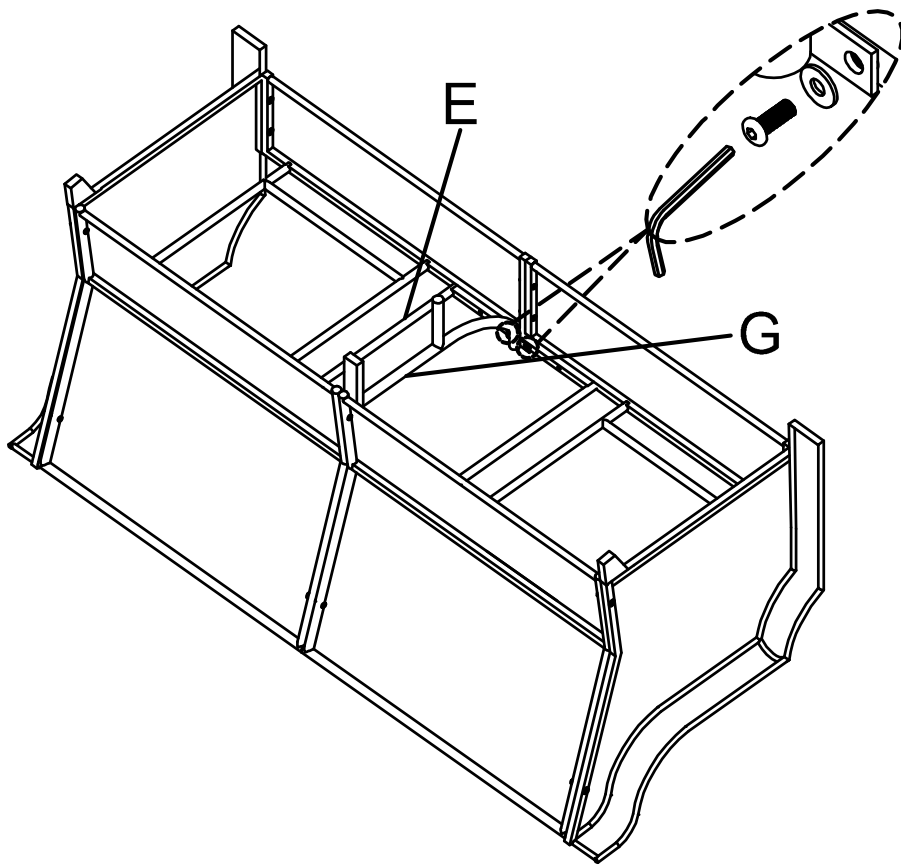

Step 8 : Attach middle seat E to seat F&D with 2pcs bolts J and 2pcs washer K. using Allen wrench L.

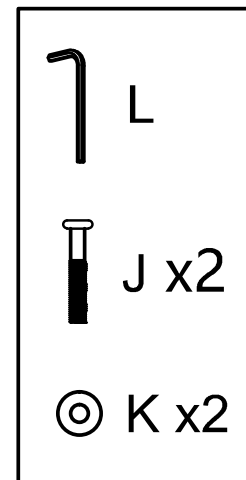
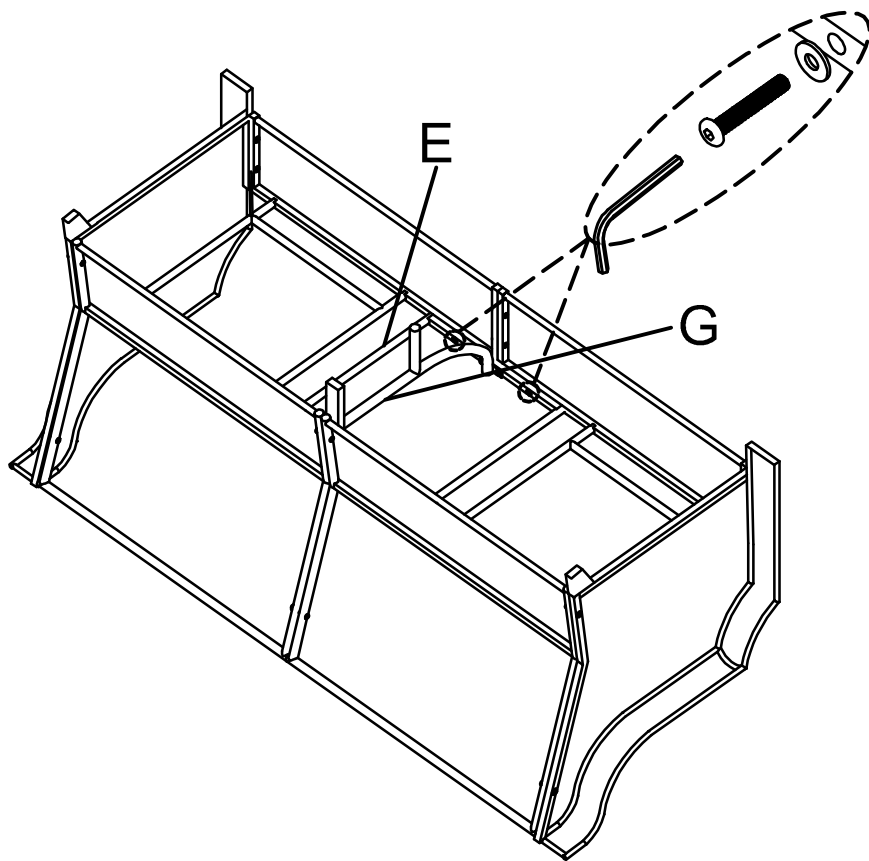

Step 9 : Attach seat to back with 6pcs bolts J and 6pcs washer K.
using Allen wrench L.

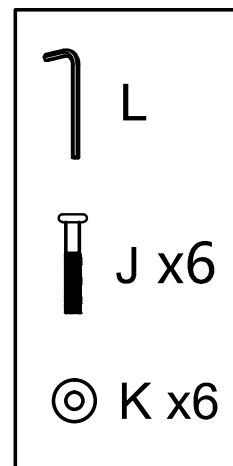
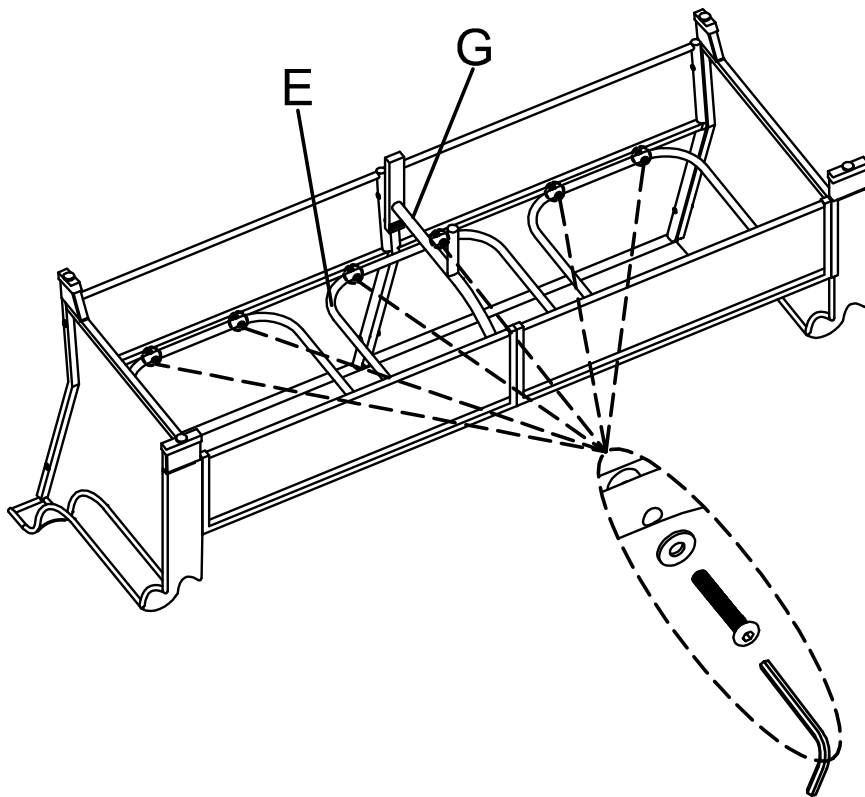

Step 10: Put back cushion O and seat cushion N onto the seat . Assembly is now complete and the product is ready for use.

