

Installation Instruction

NOTE:

1. the product by manual welding, part of the uneven is a normal phenomenon, can be adjusted by manpower.
2. Do not tighten the screws during installation.
3. Please unscrew the screws from the shelf.

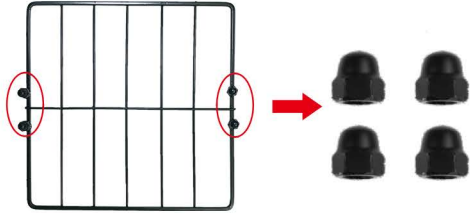

A



2PCS

B



2PCS

C



5PCS

D



2PCS

E

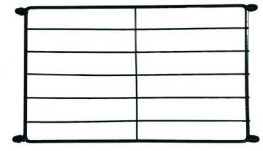

1PC

1

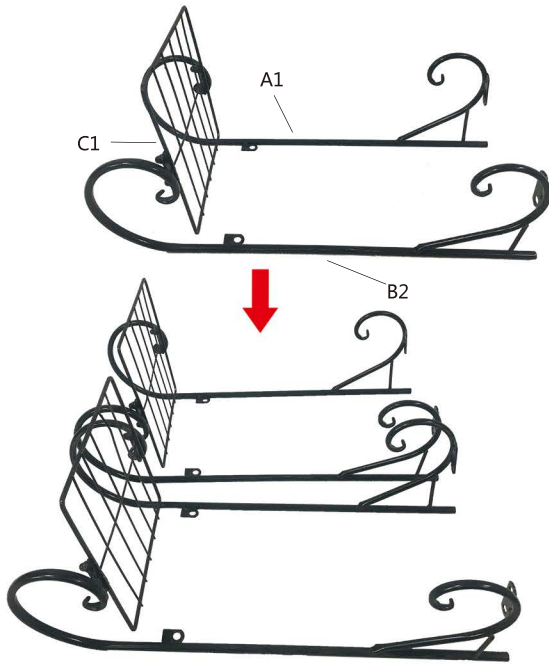

1. Connect C and A

2

2. Install part D in "n" shape

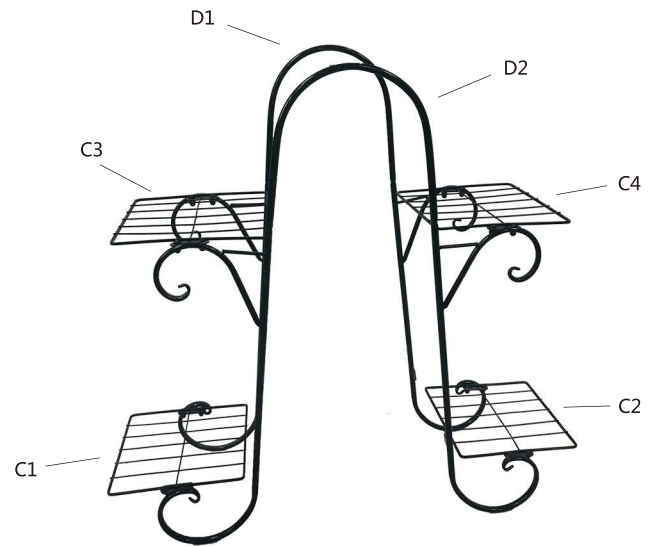

3

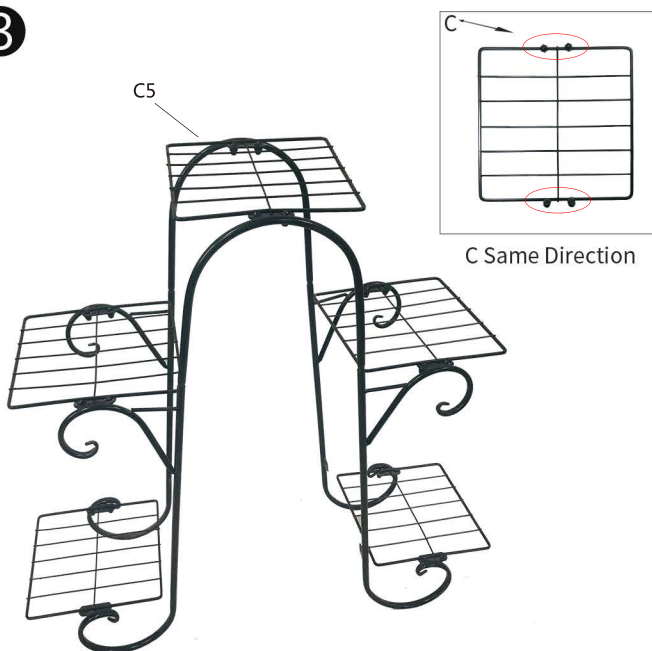

3. Use C to connect already assembled components

4

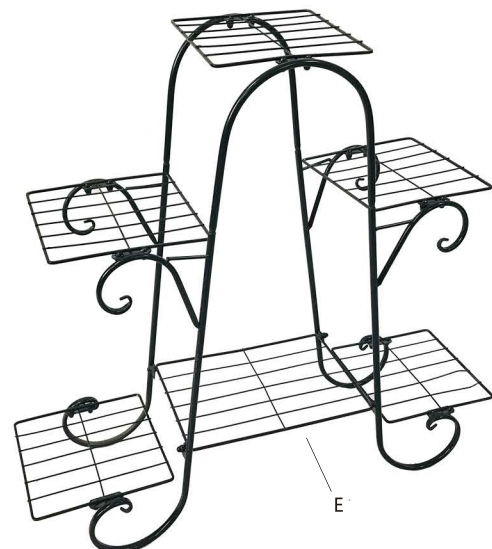

4. Tighten the screws that connect E, finally tighten all the screws.

PS: Don't stretch E too violence