

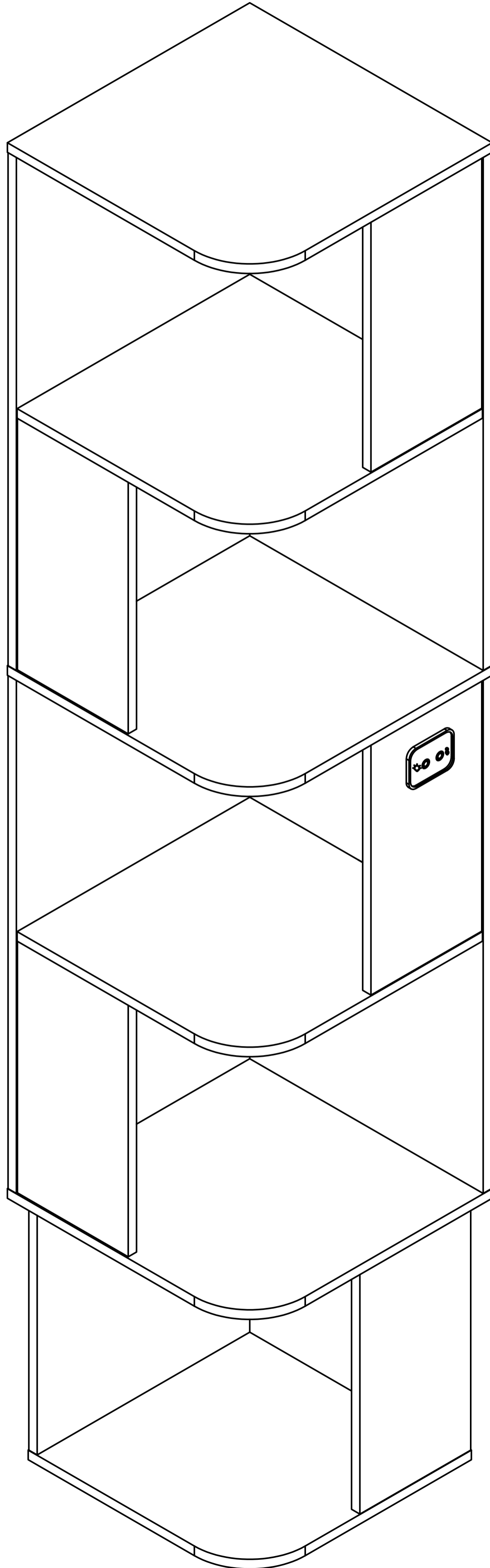

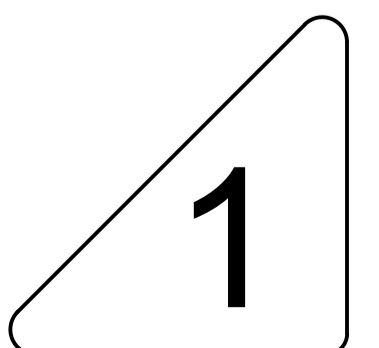

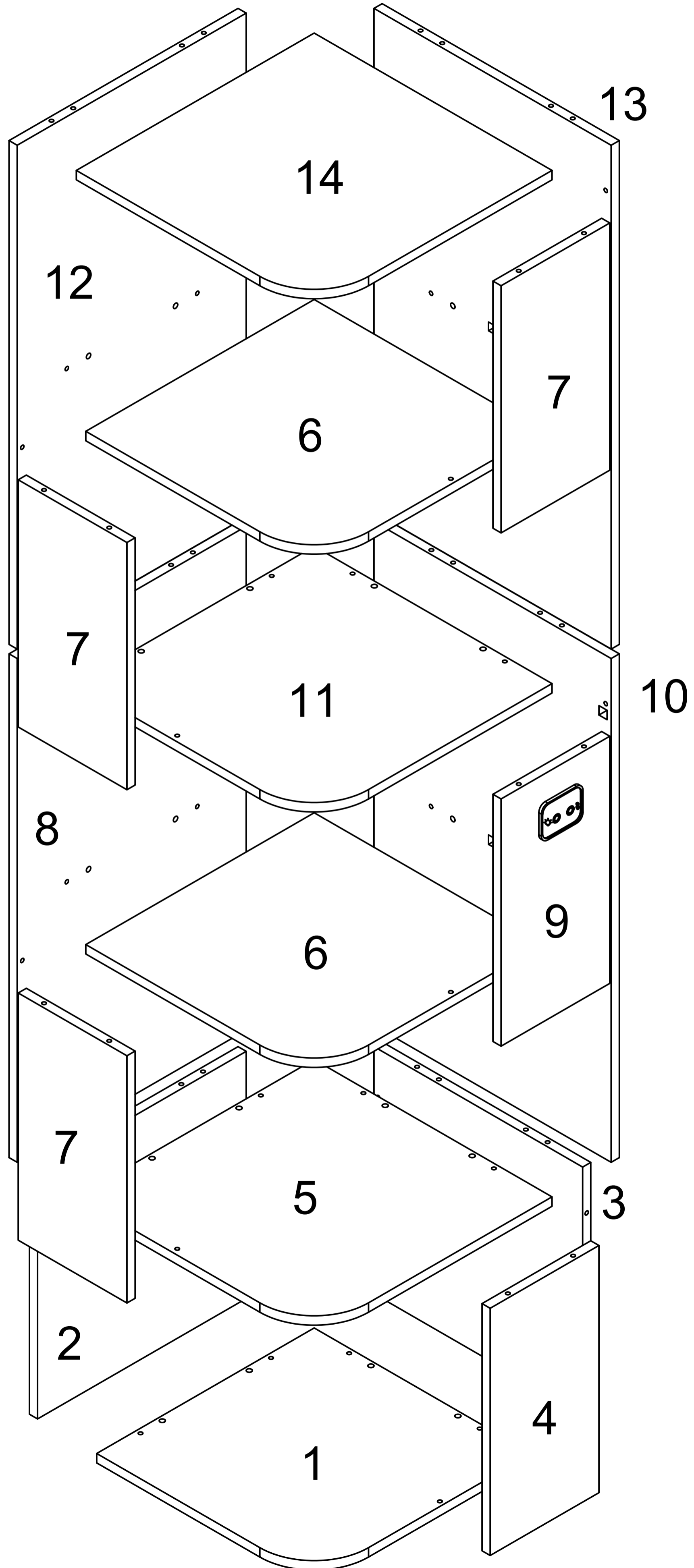





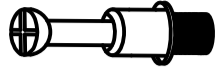

Product Installation Guide

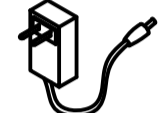

Decomposition of Product structure

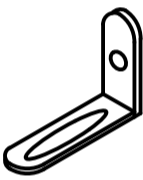

Accessories list

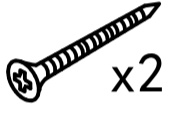
A		Two in one screw (6x28mm)	68pcs +2pcs		
B		Two in one nut (10x12mm)	68pcs +3pcs		
C		Wood Chipping (6x30mm)	38pcs +2pcs		
D		Non-slip pads(36x36mm)	4pcs		
E		power cord extension cord	1pcs		
			1pcs		
F		AC/DC Adapter (12V=2.0A)	1pcs		
G		Wire Clamp	2pcs		
Anti tipping hardware					
H	 x2	 x4	 x2	 (3.5x14mm) x2	 x2 (4x45mm)

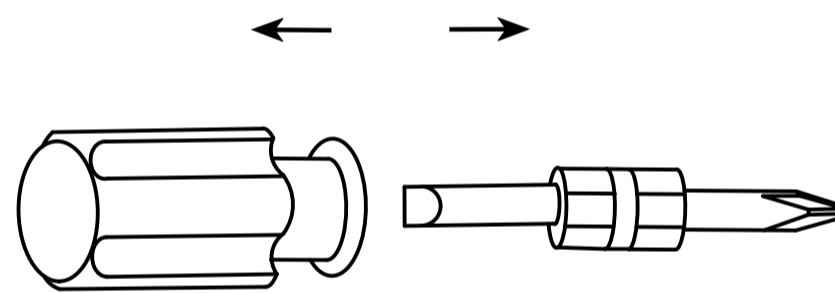
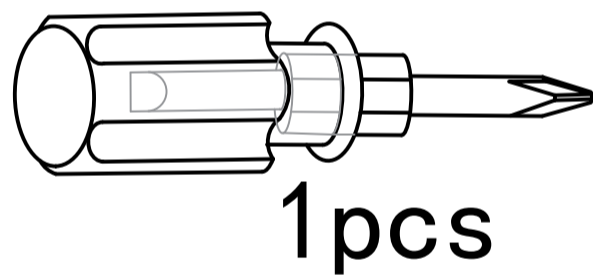

Double-head screwdriver, use as required

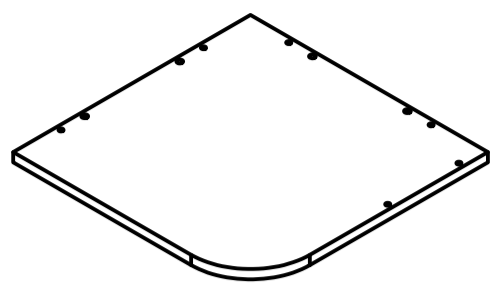

1x1

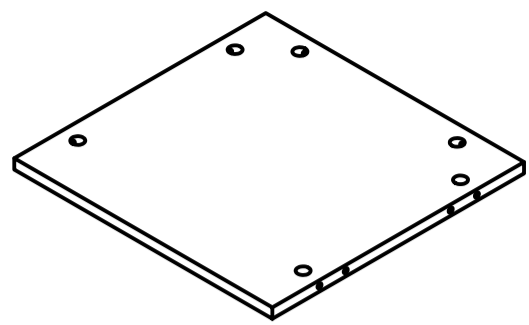

2x1

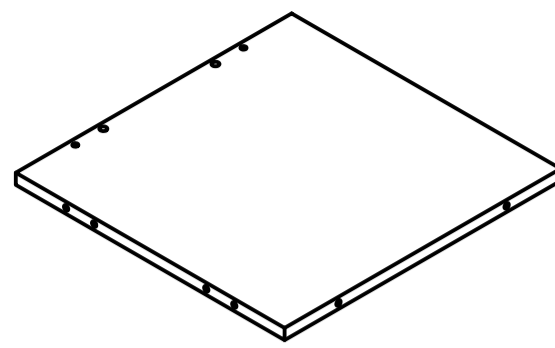

3x1

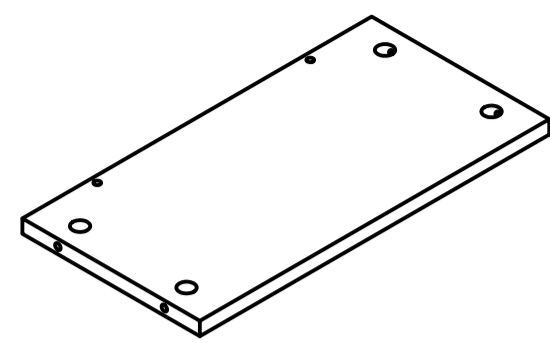

4x1

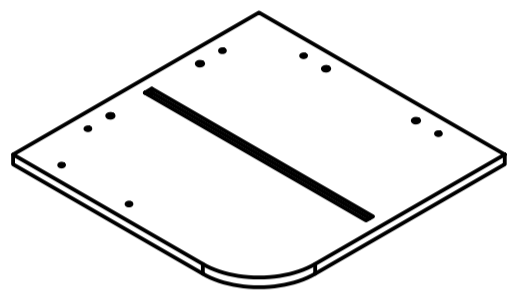

5x1

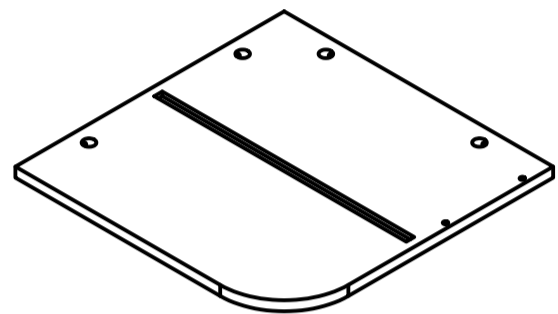

6x2

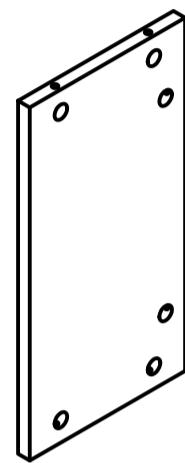

7x3



8x1

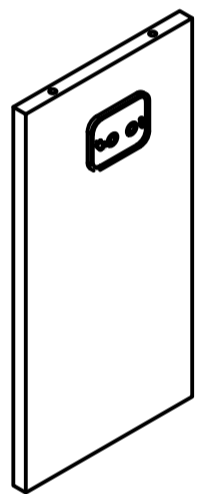

9x1

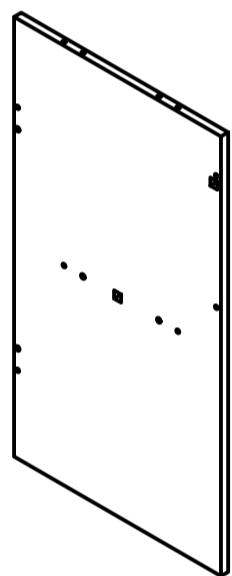

10x1

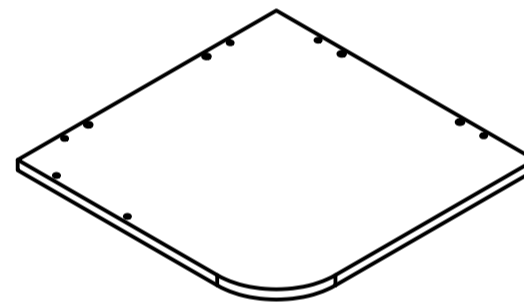

11x1



12x1

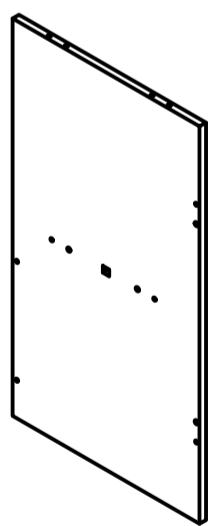

13x1

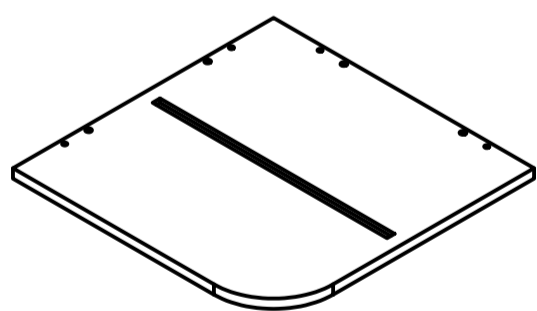

14x1

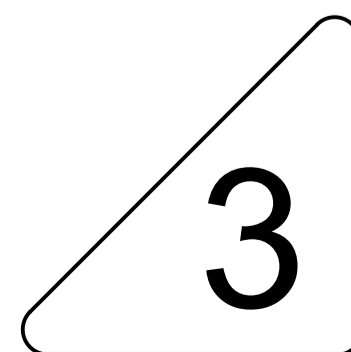

3

Decomposition of Product structure

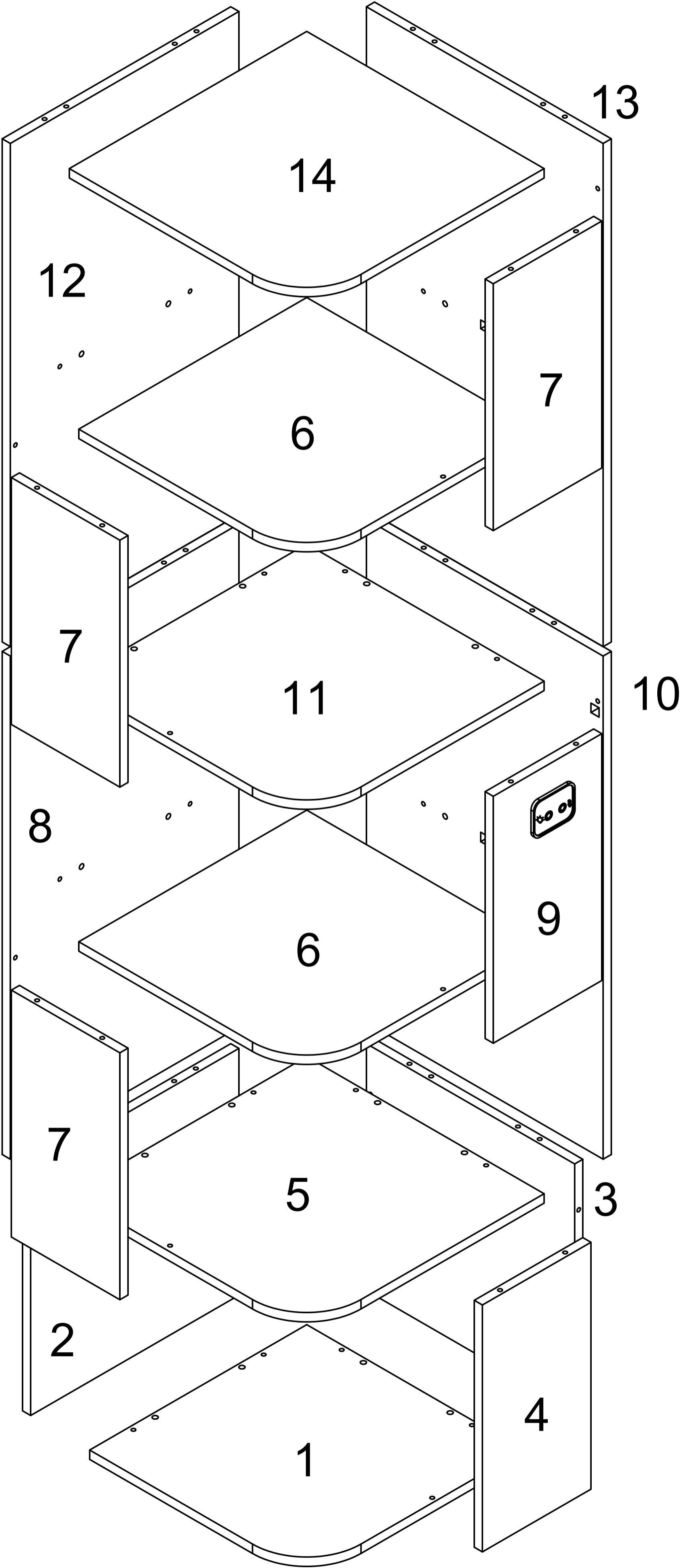

Use parts A and B

Step 1

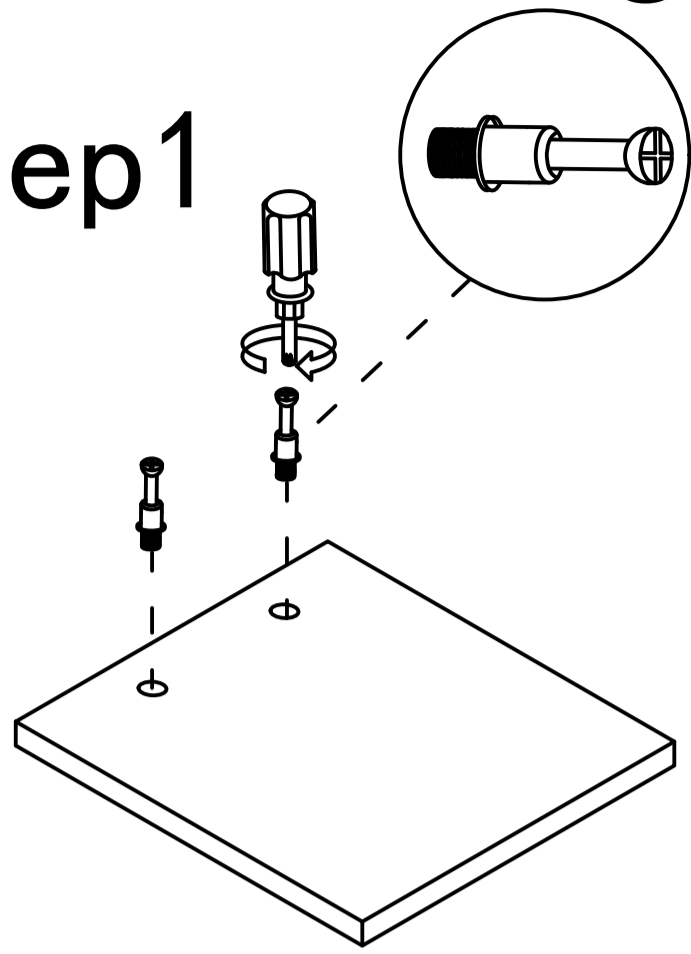

Step 2

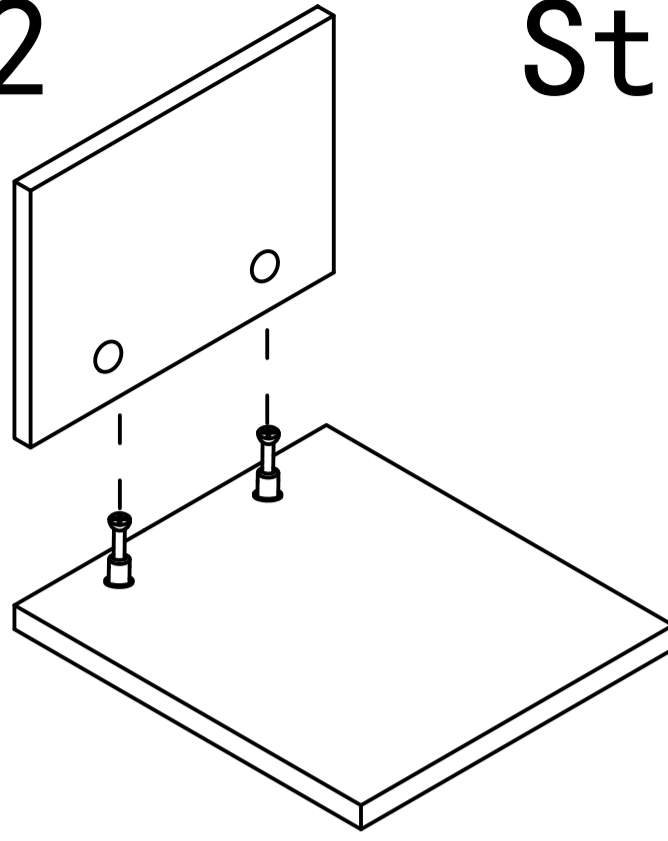

Step 3

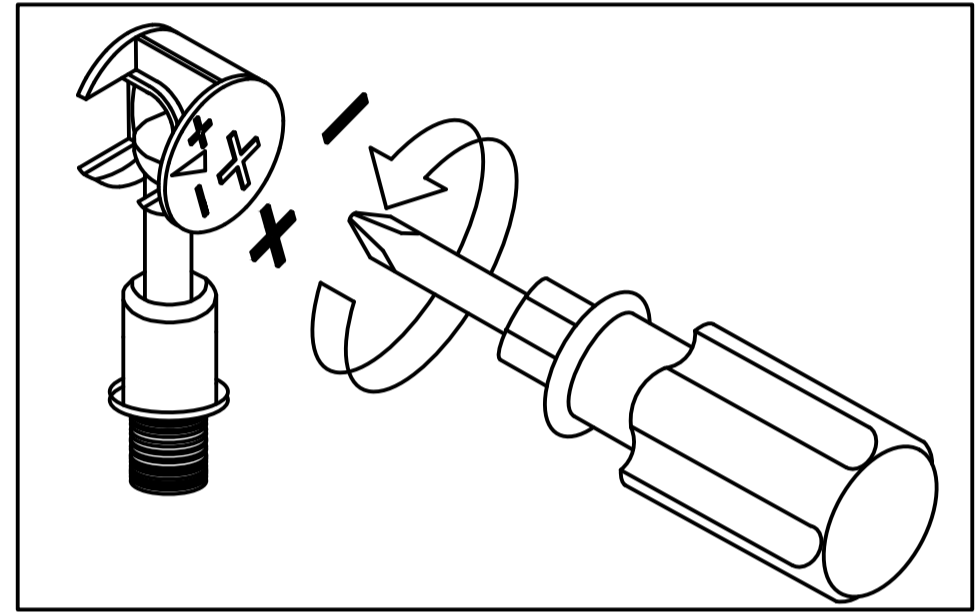
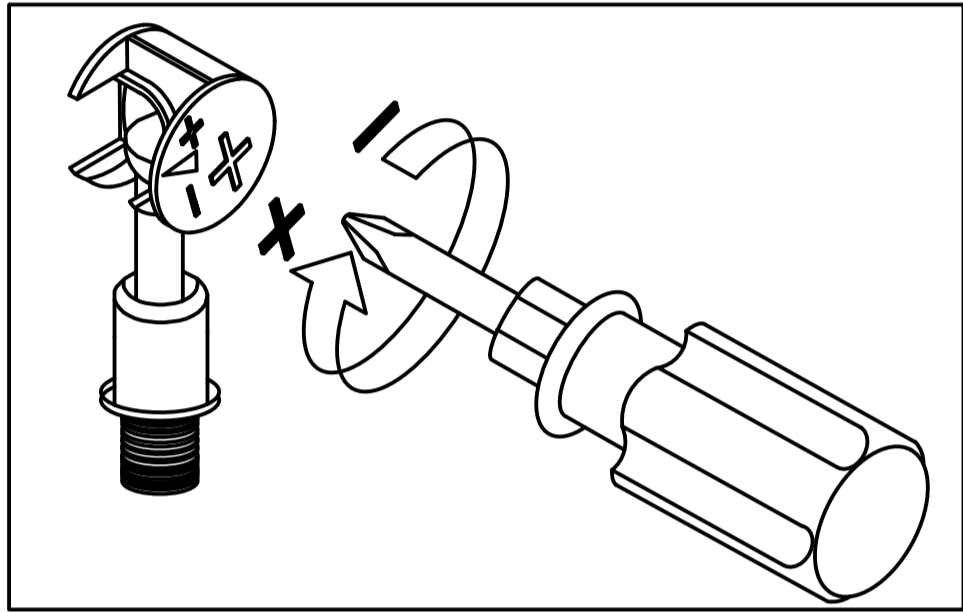
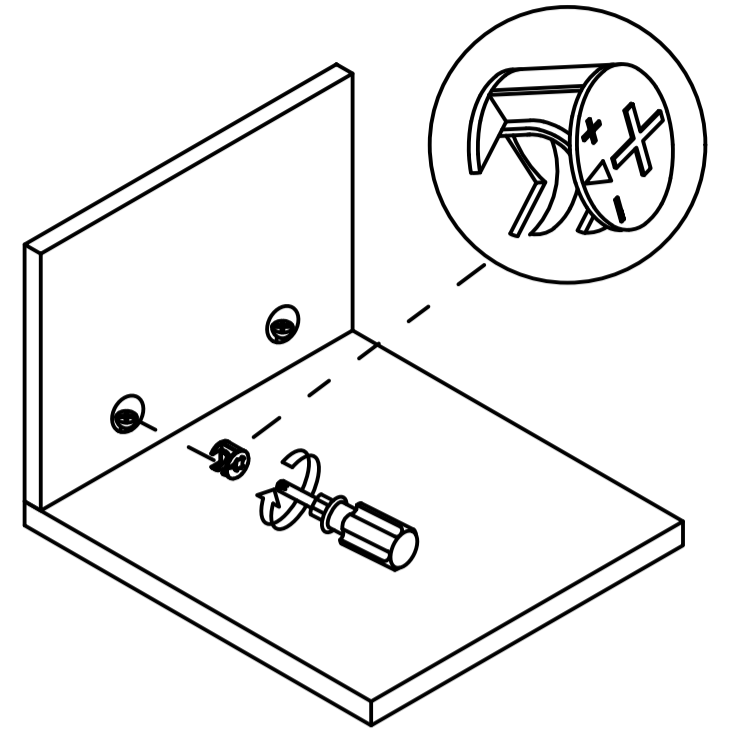

Use ascrewdriver to tighten in the direction of the '+' sign.

Disassemble dong the '-' sign direction.

Step 1

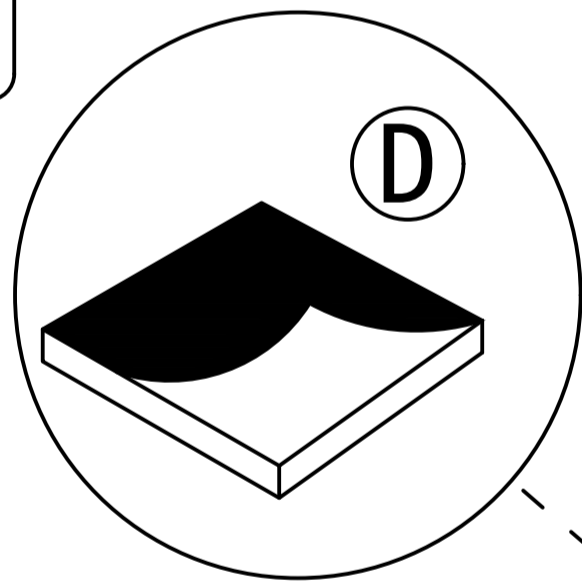

Remove the protective film before installation

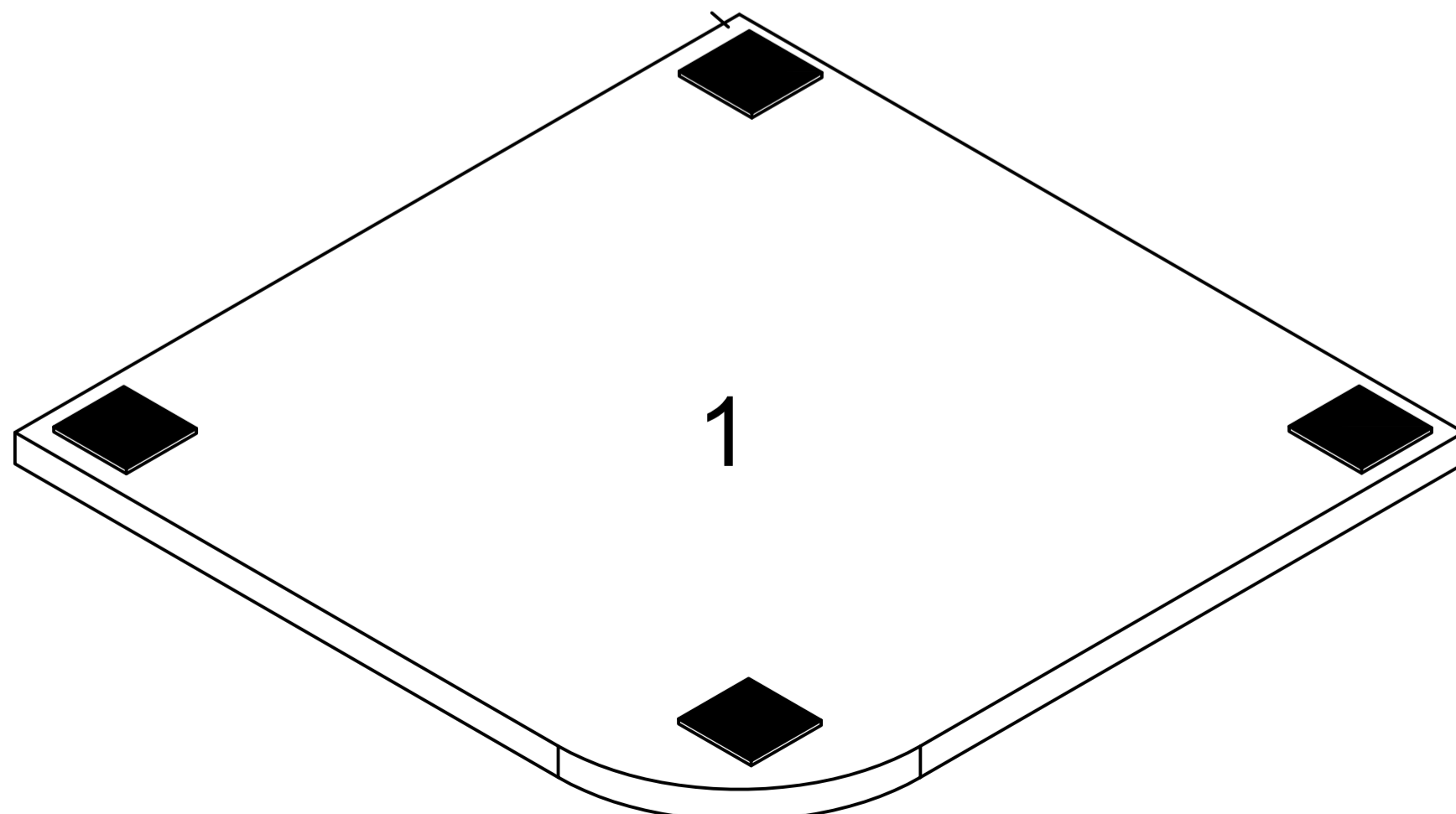
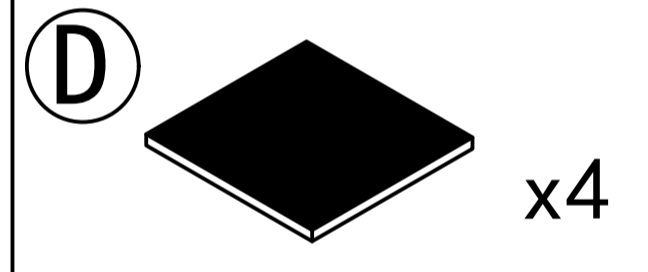

Step 2

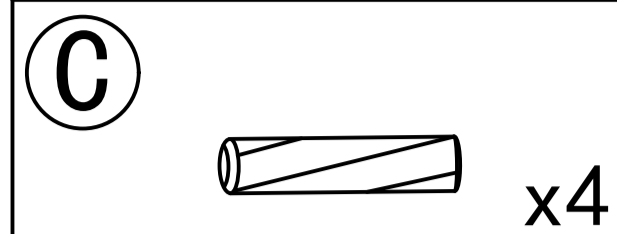
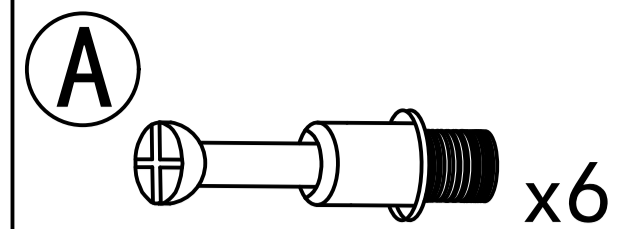
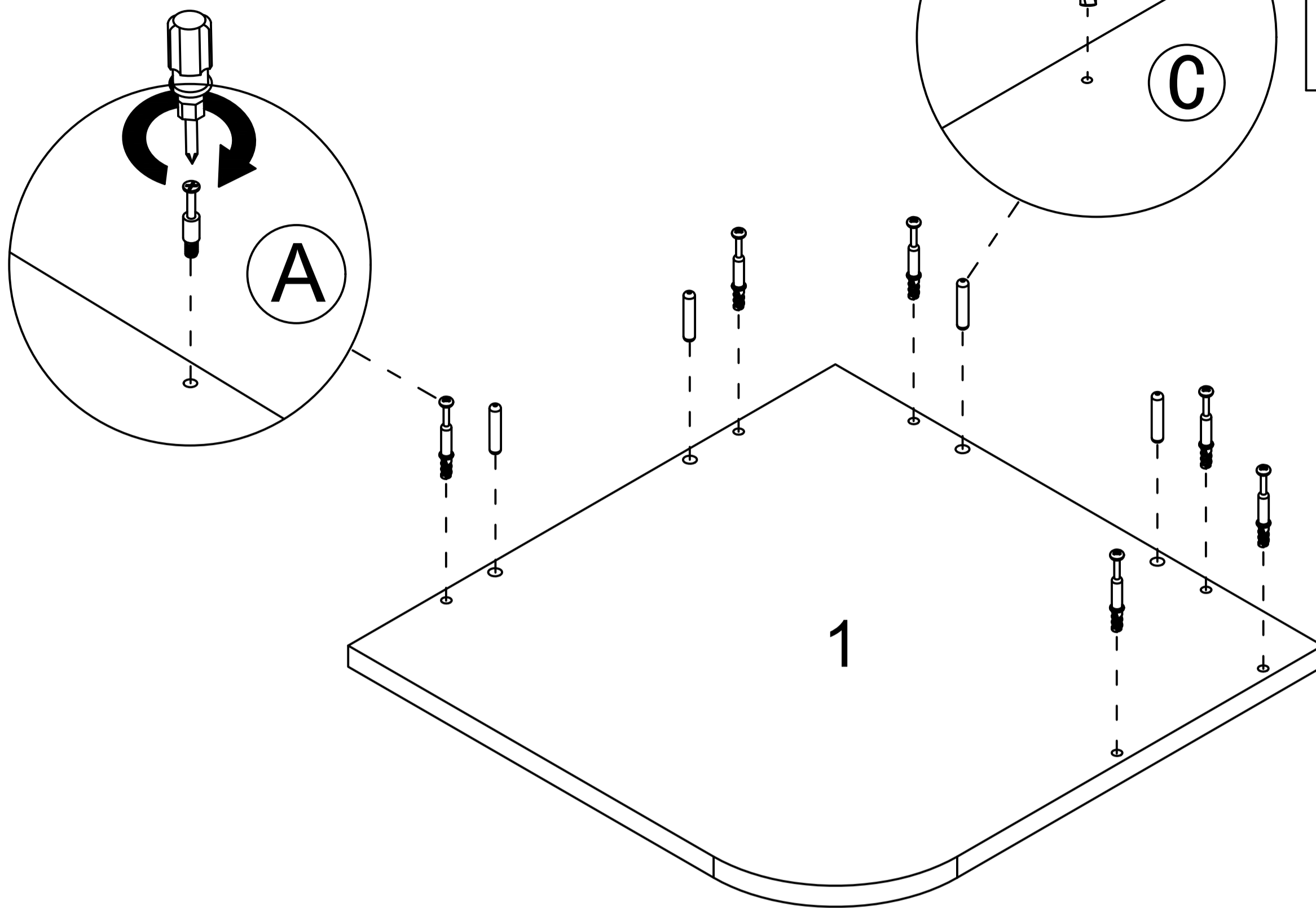

Step 3

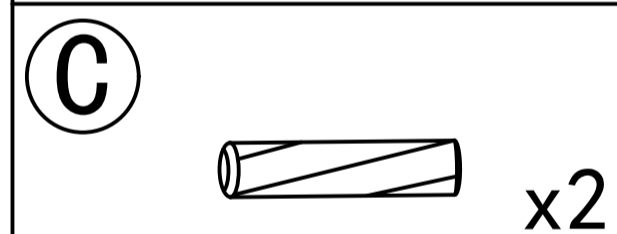
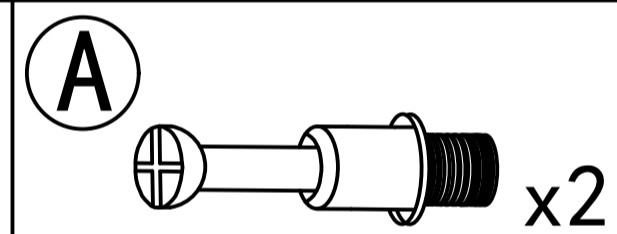
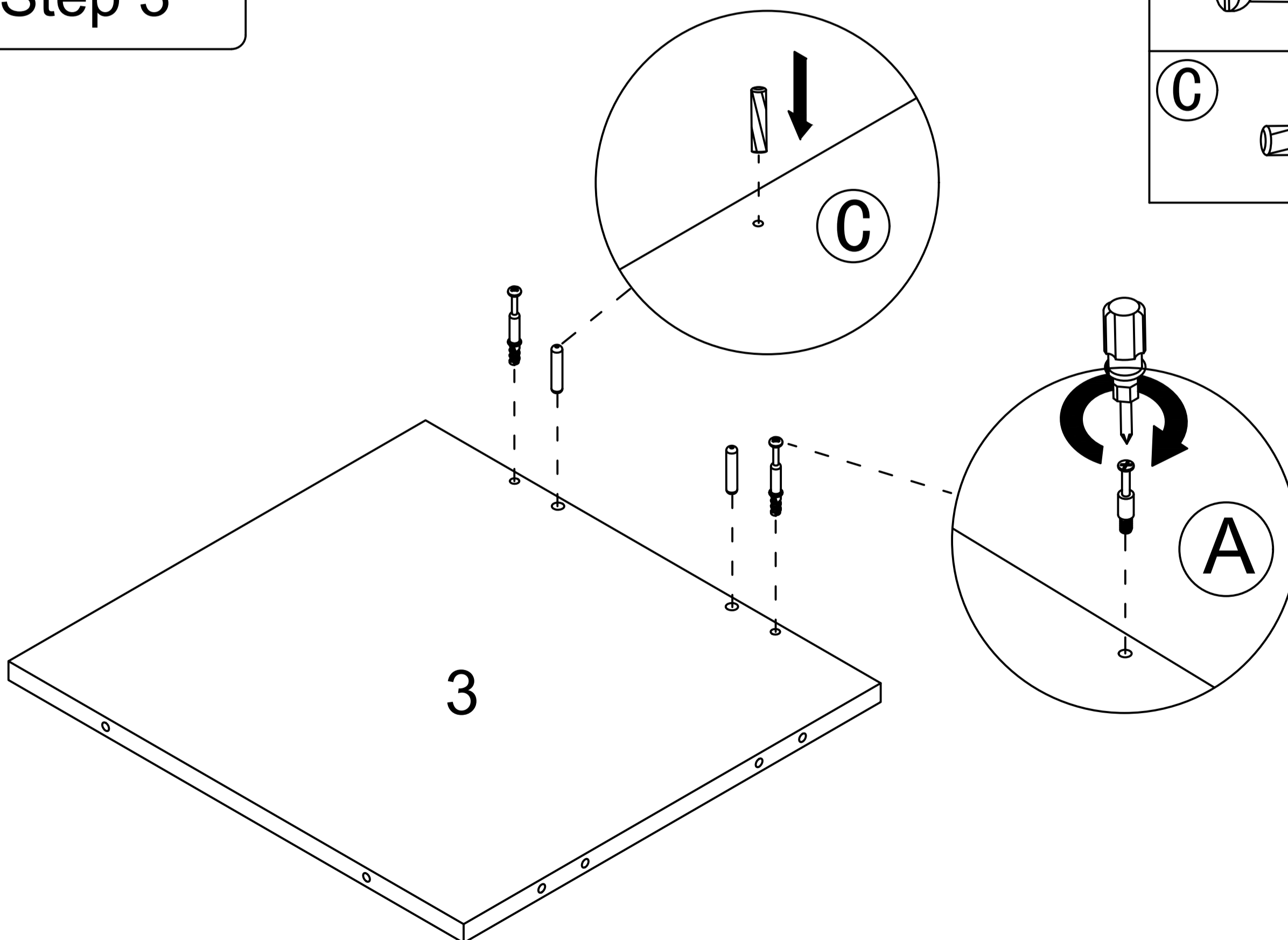

Step 4

(B)  x2

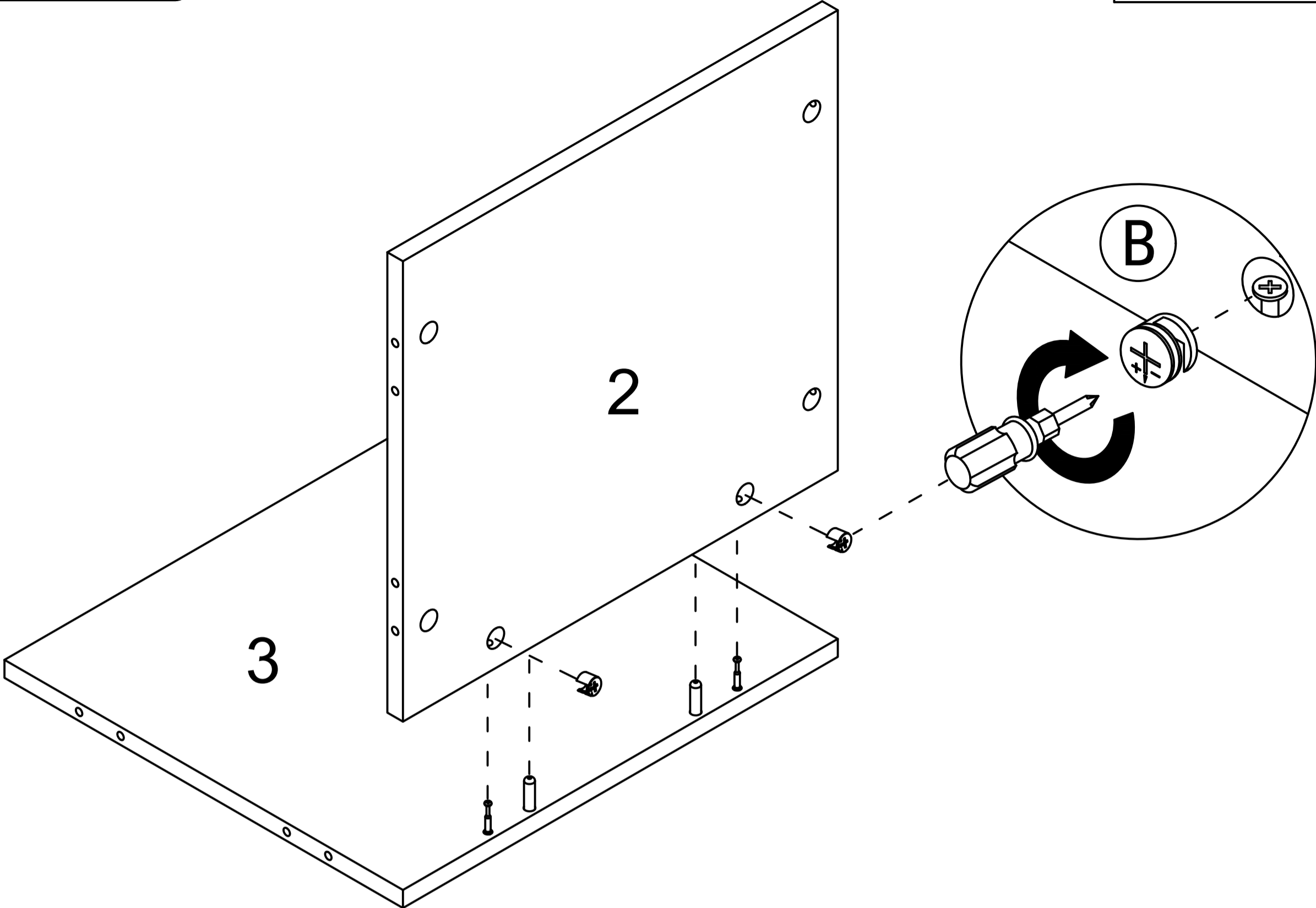

Step 5

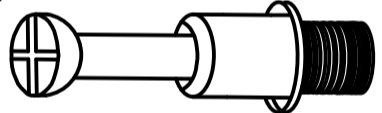
(A)  x2

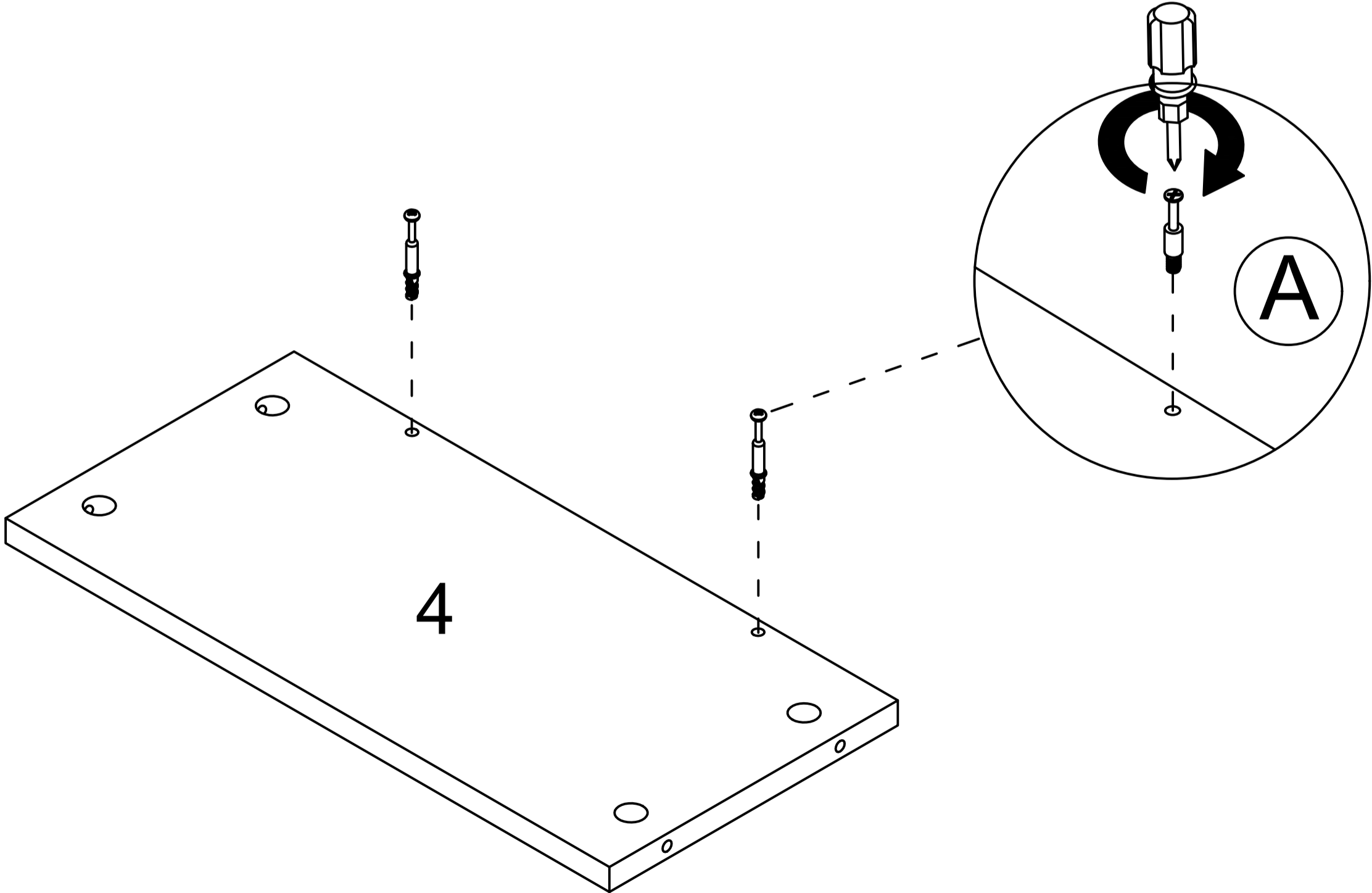

Step 6

B



x2

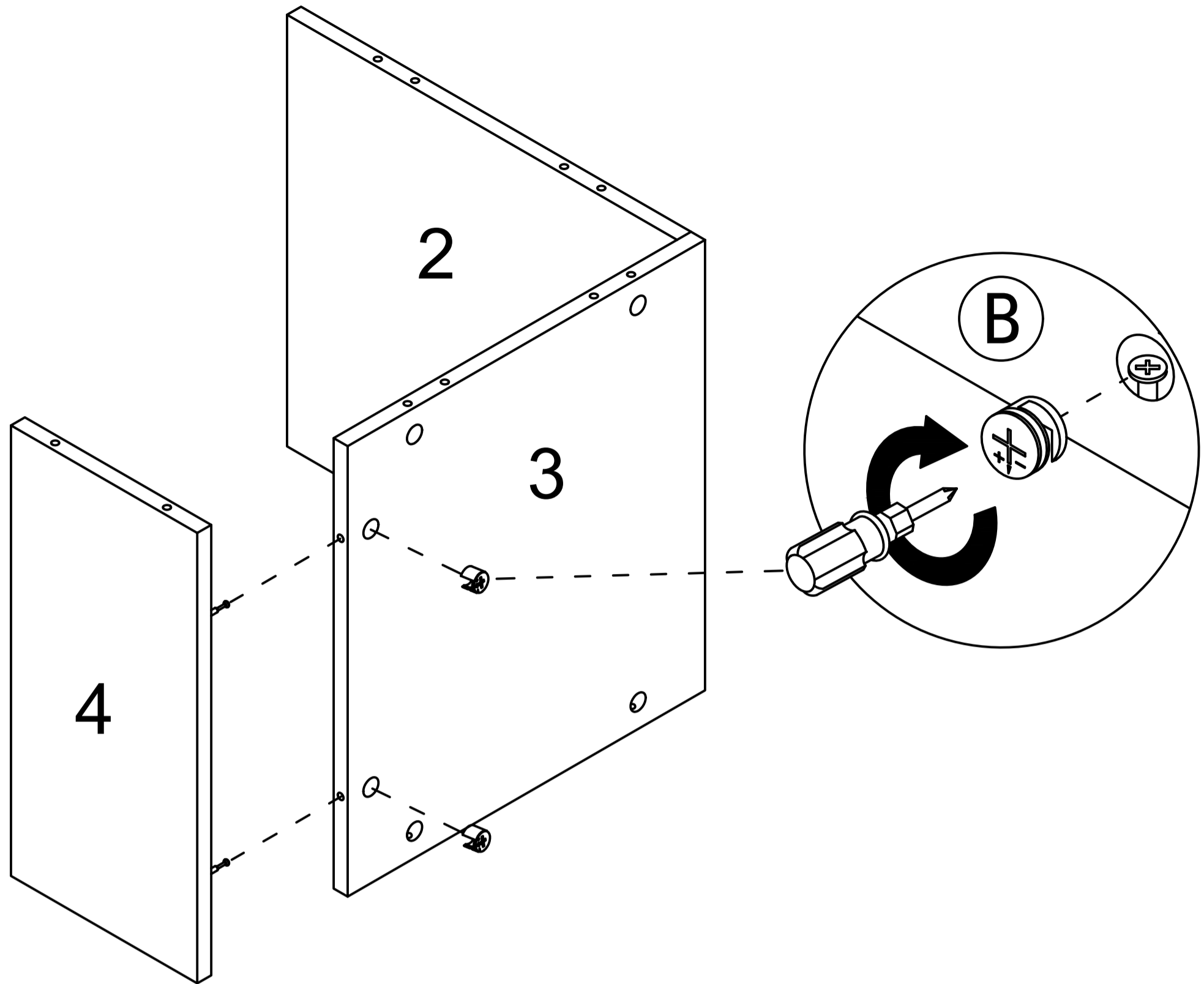

Step 7

B



x4

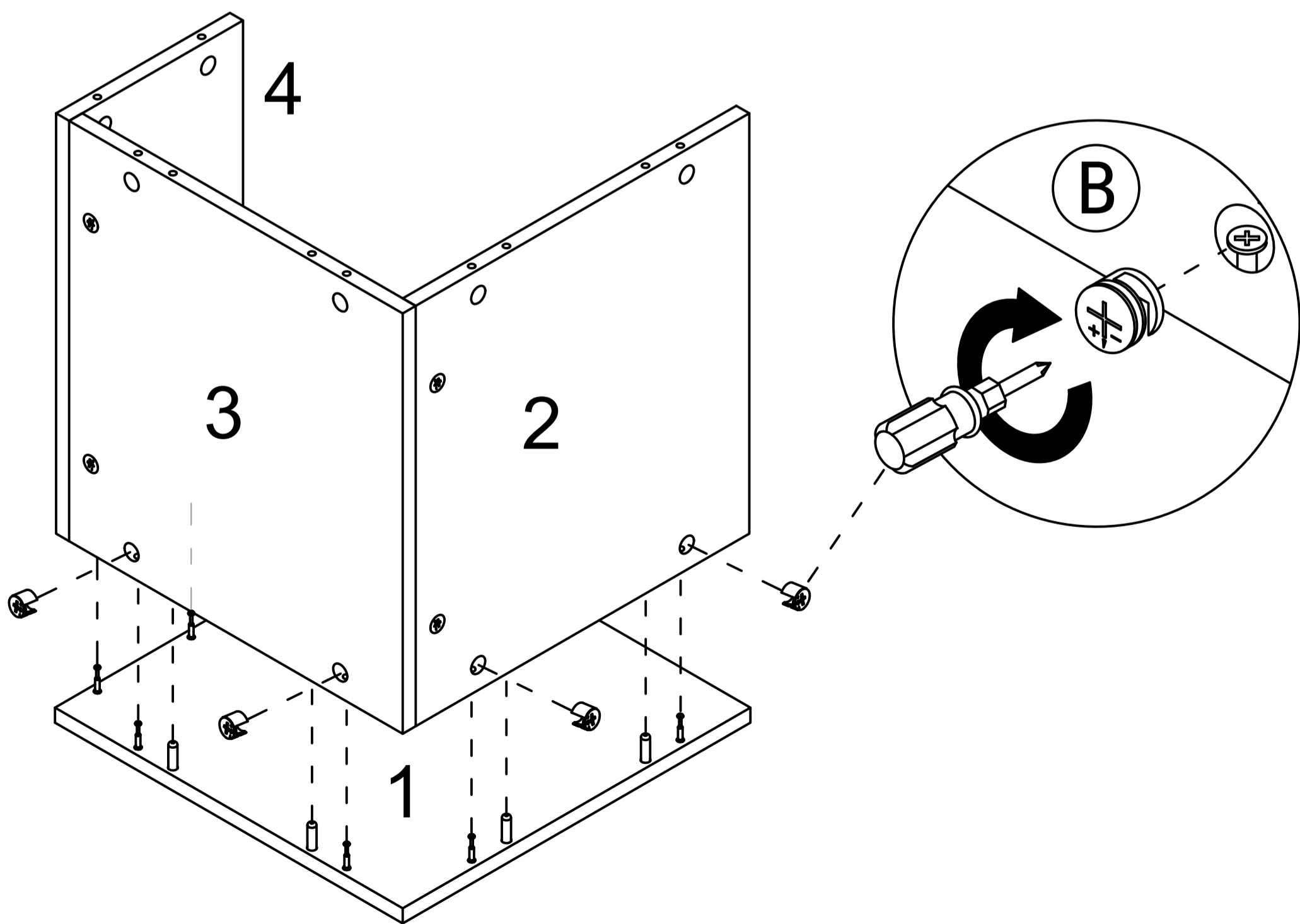

Step 8

B  x2

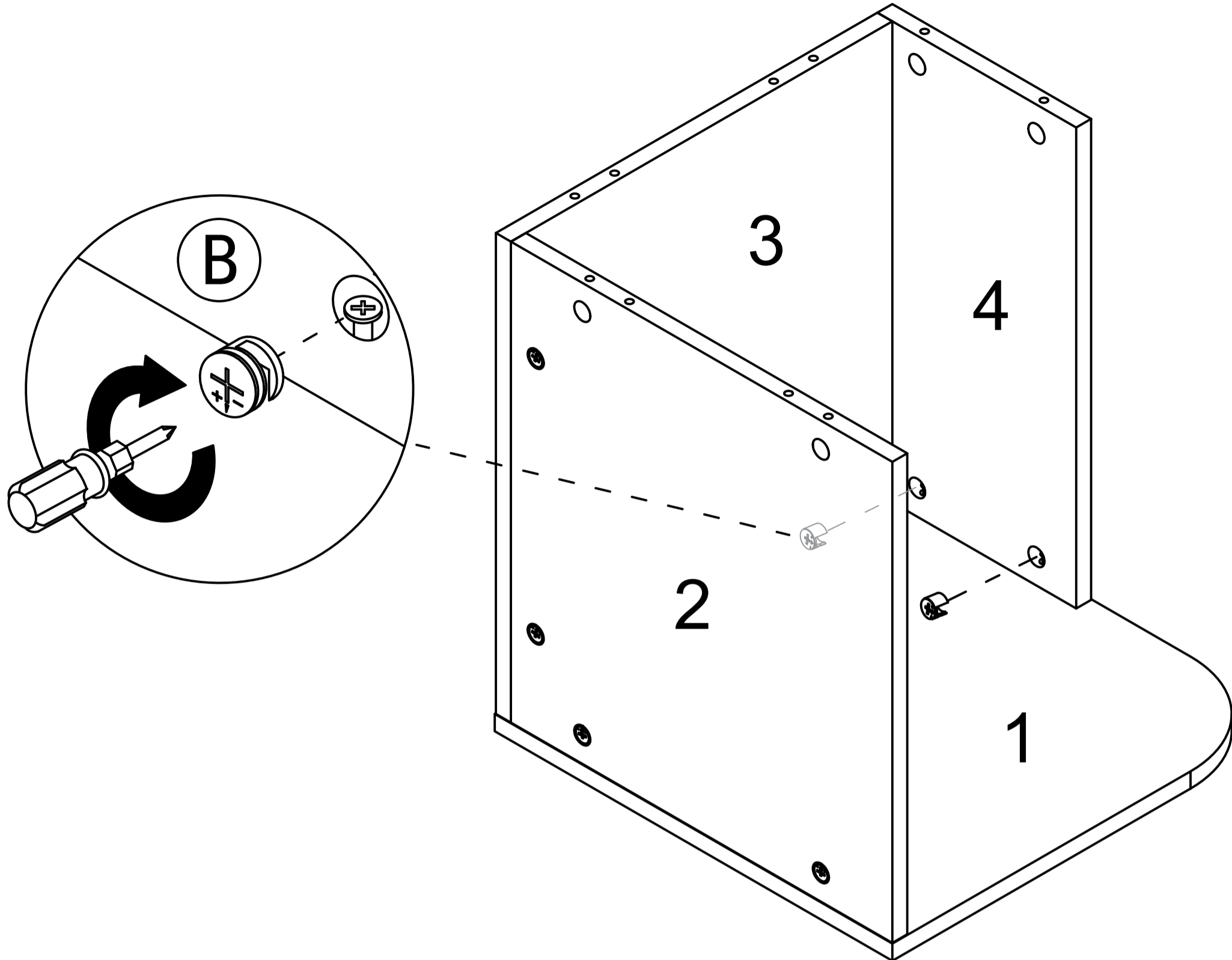

Step 9

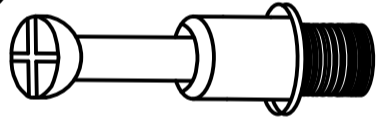
A  x6

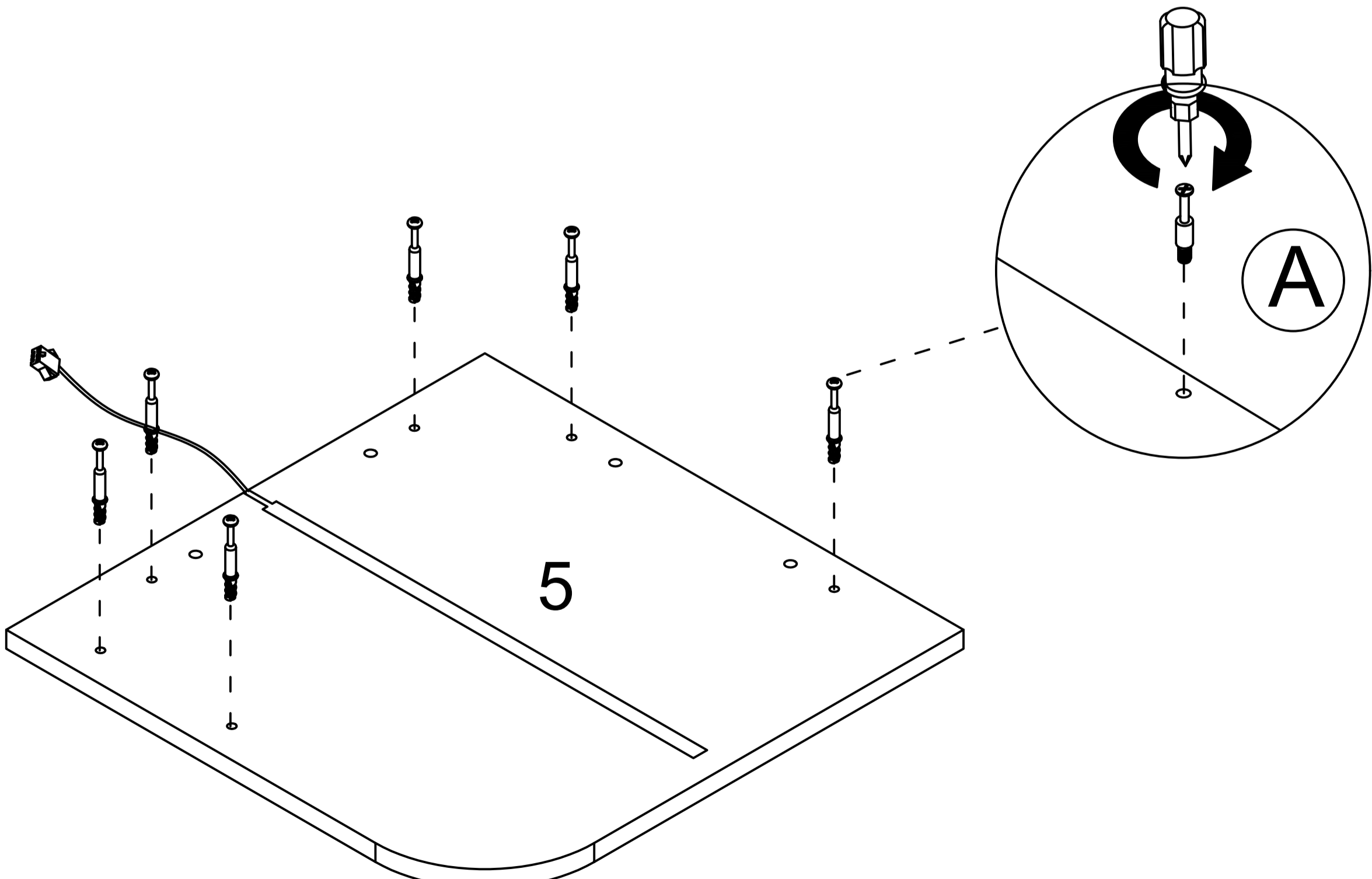

Step 10

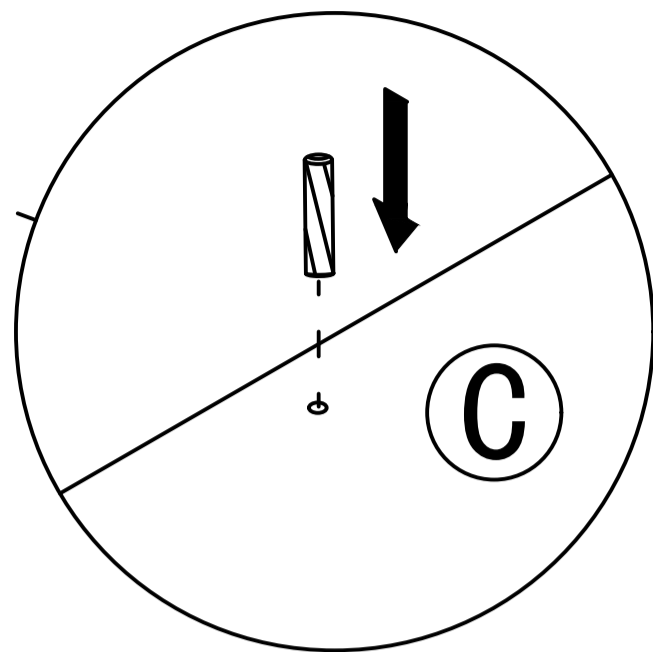
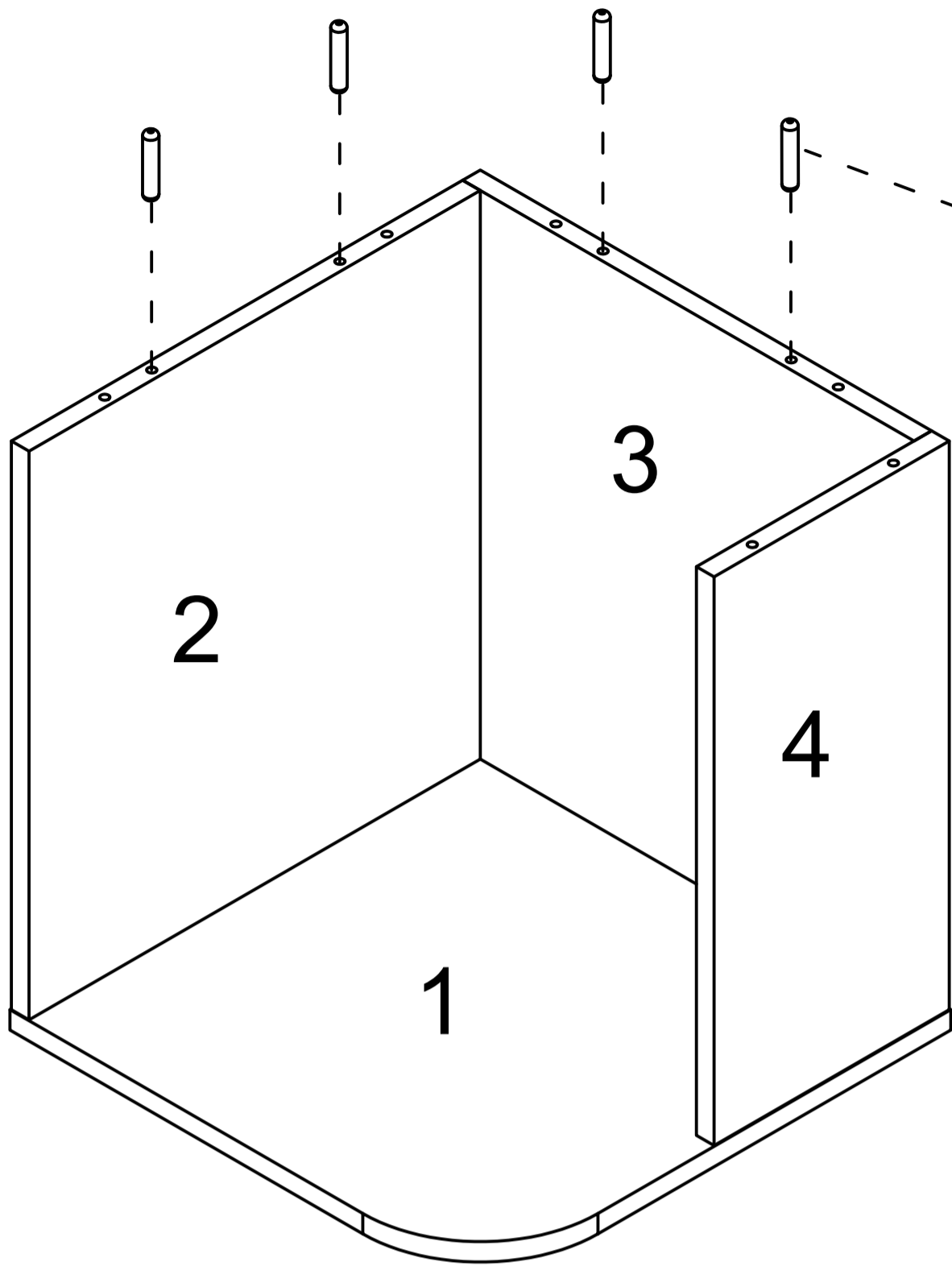
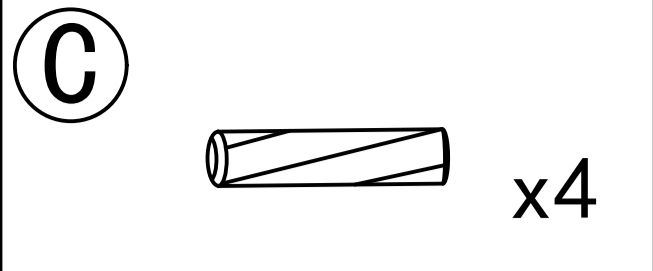

Step 11

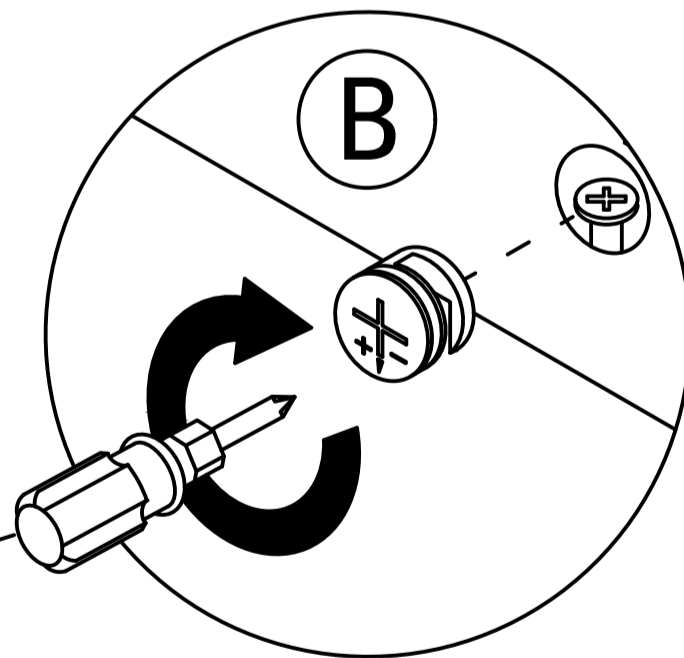
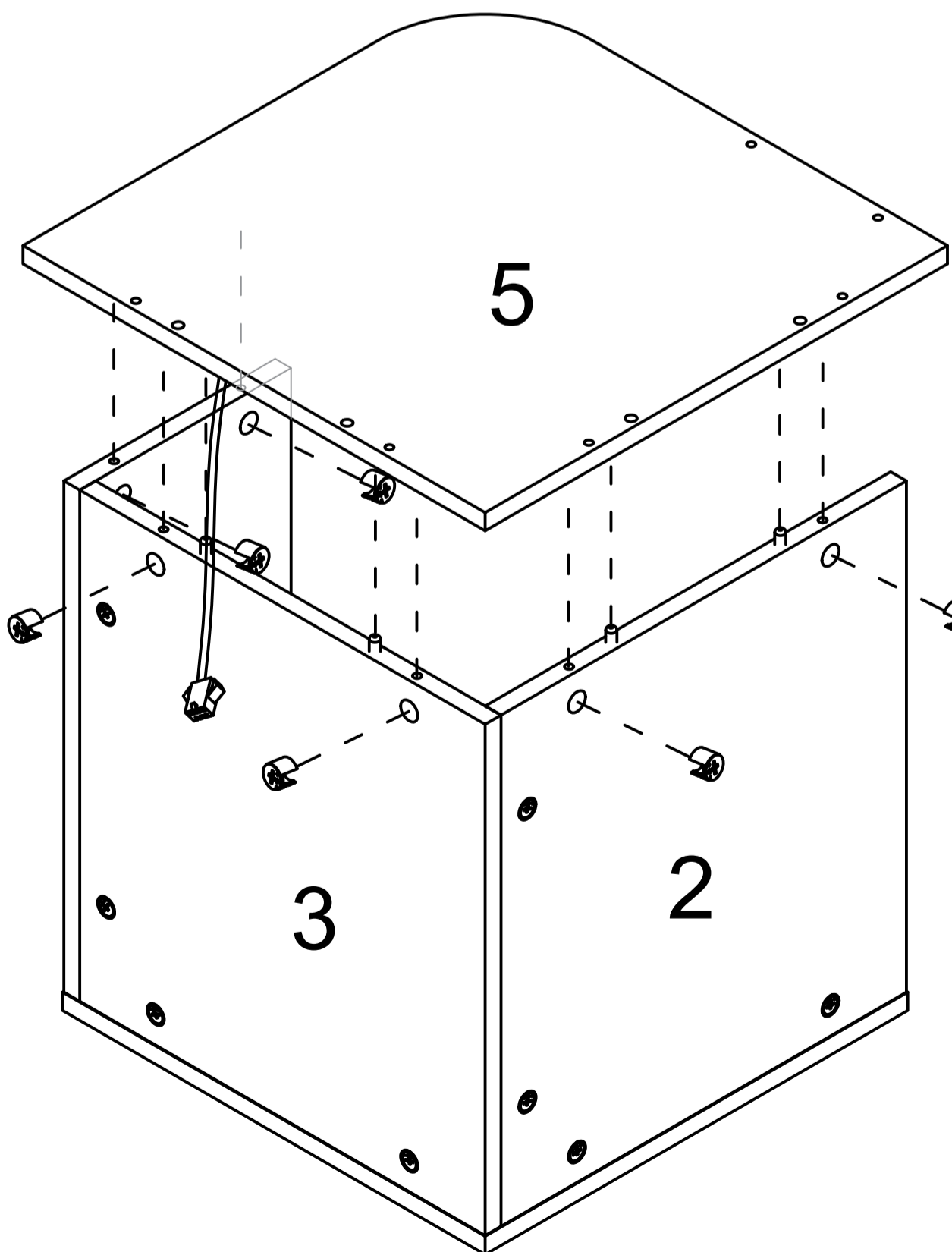

Step 12

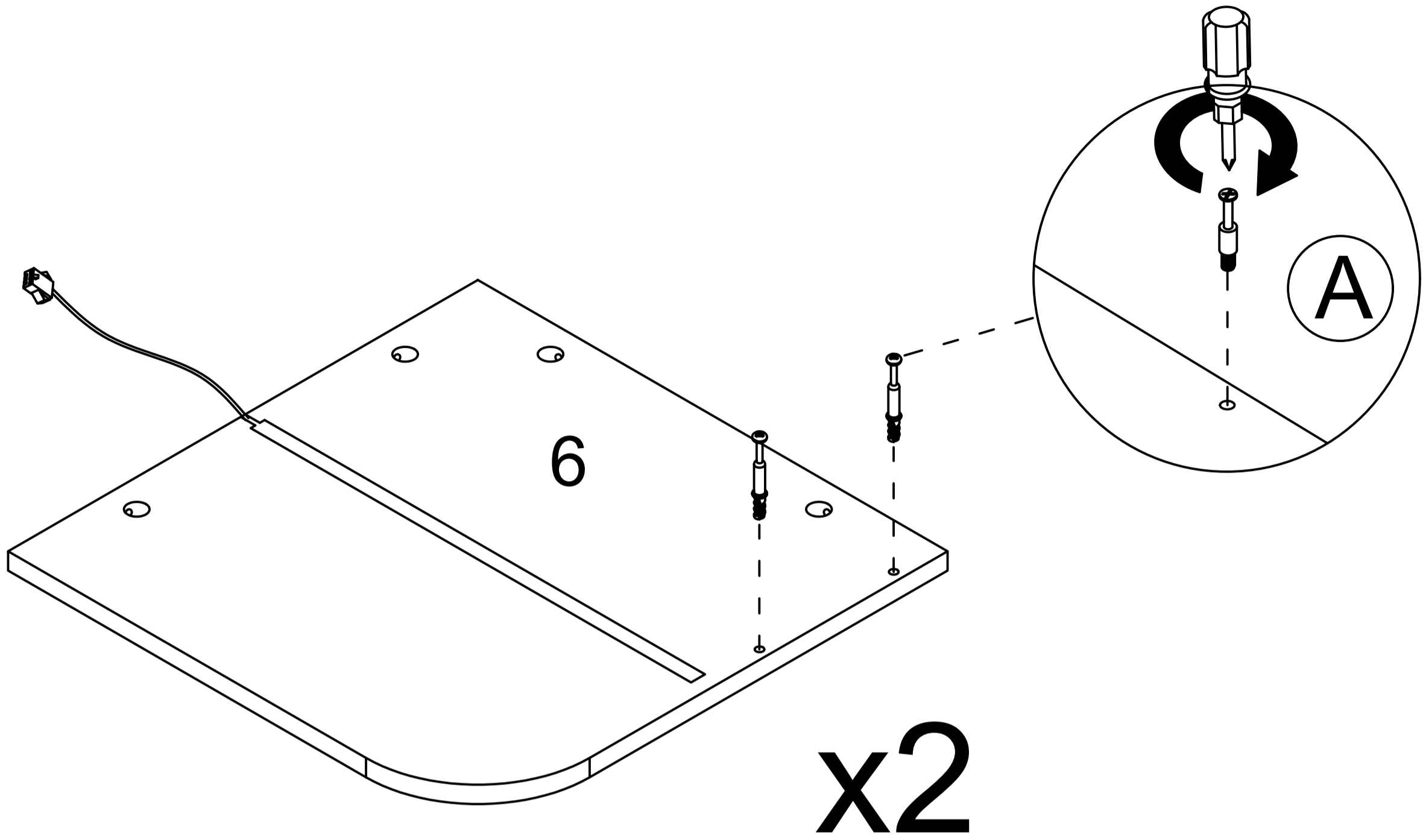
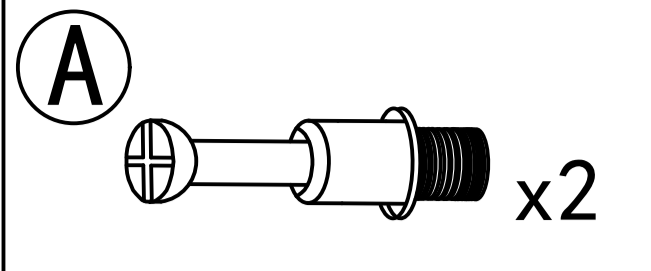

Repeat this step twice

Step 13

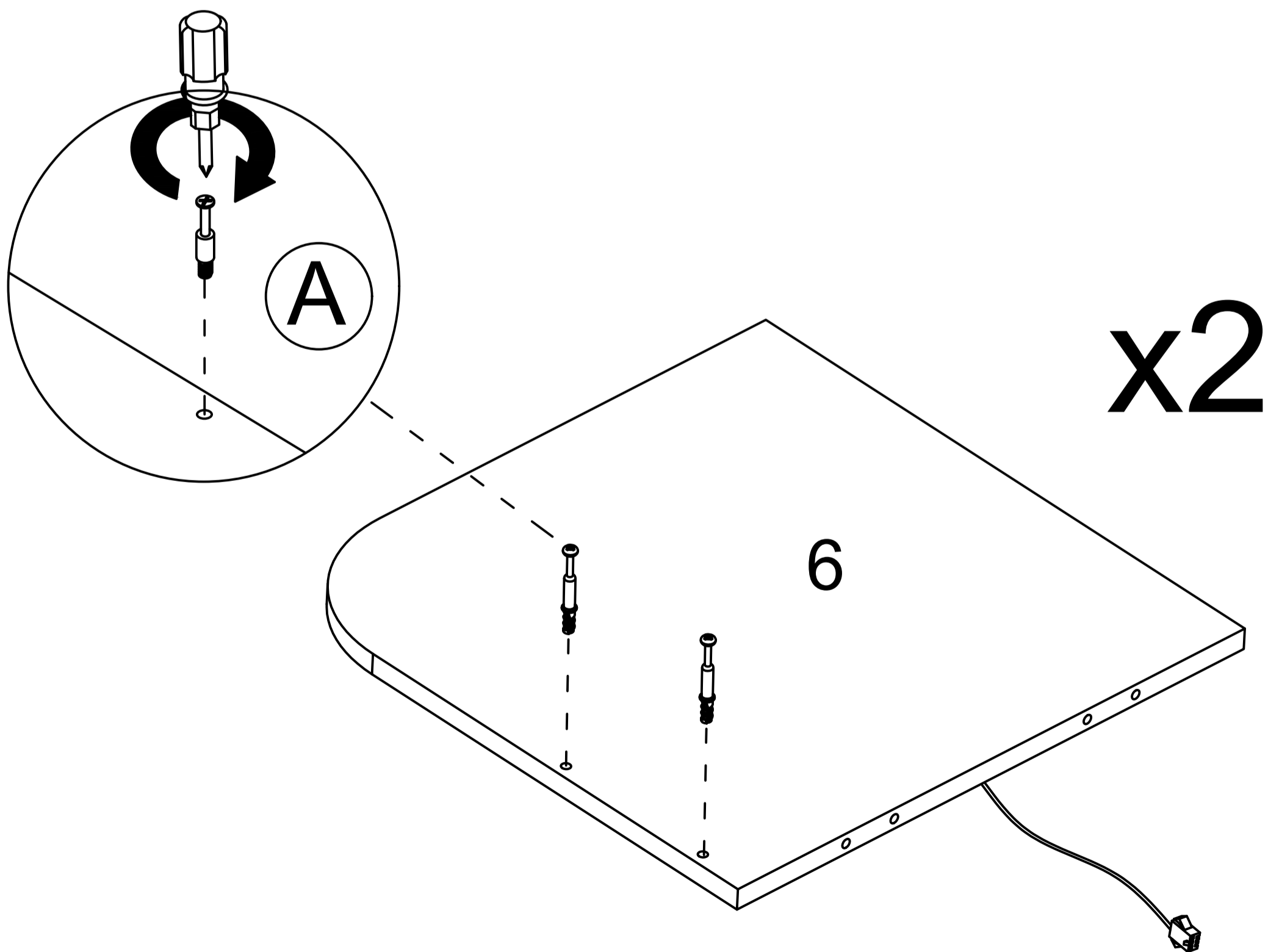
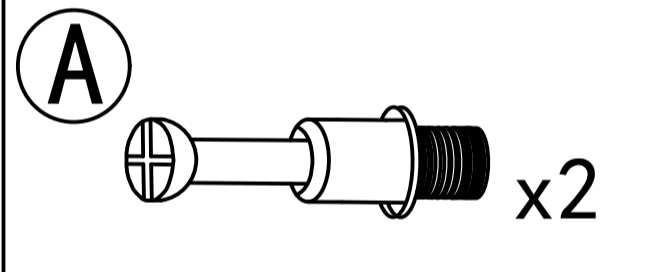

Repeat this step twice

Step 14

(B)  x2

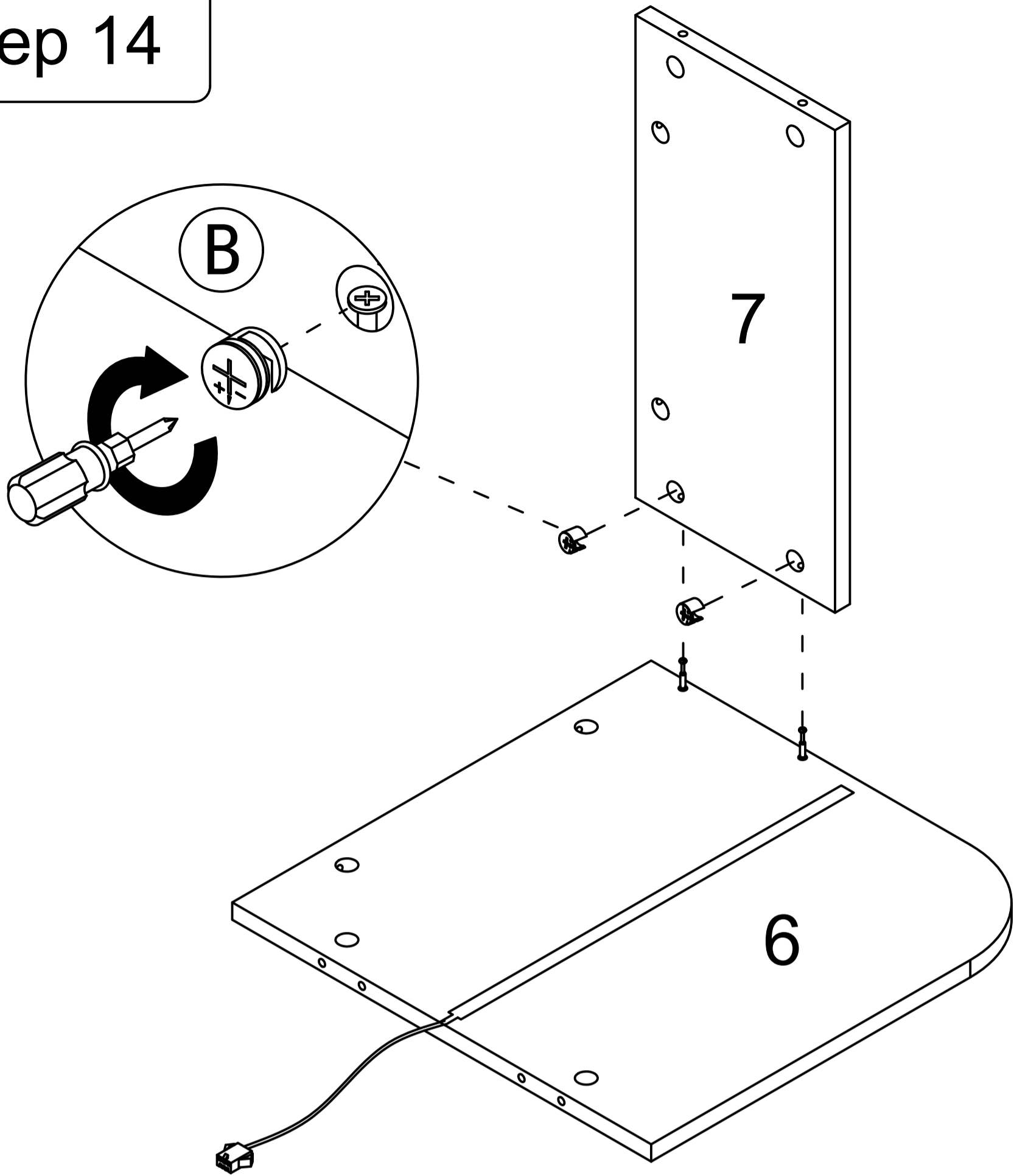

Step 15

(B)  x2

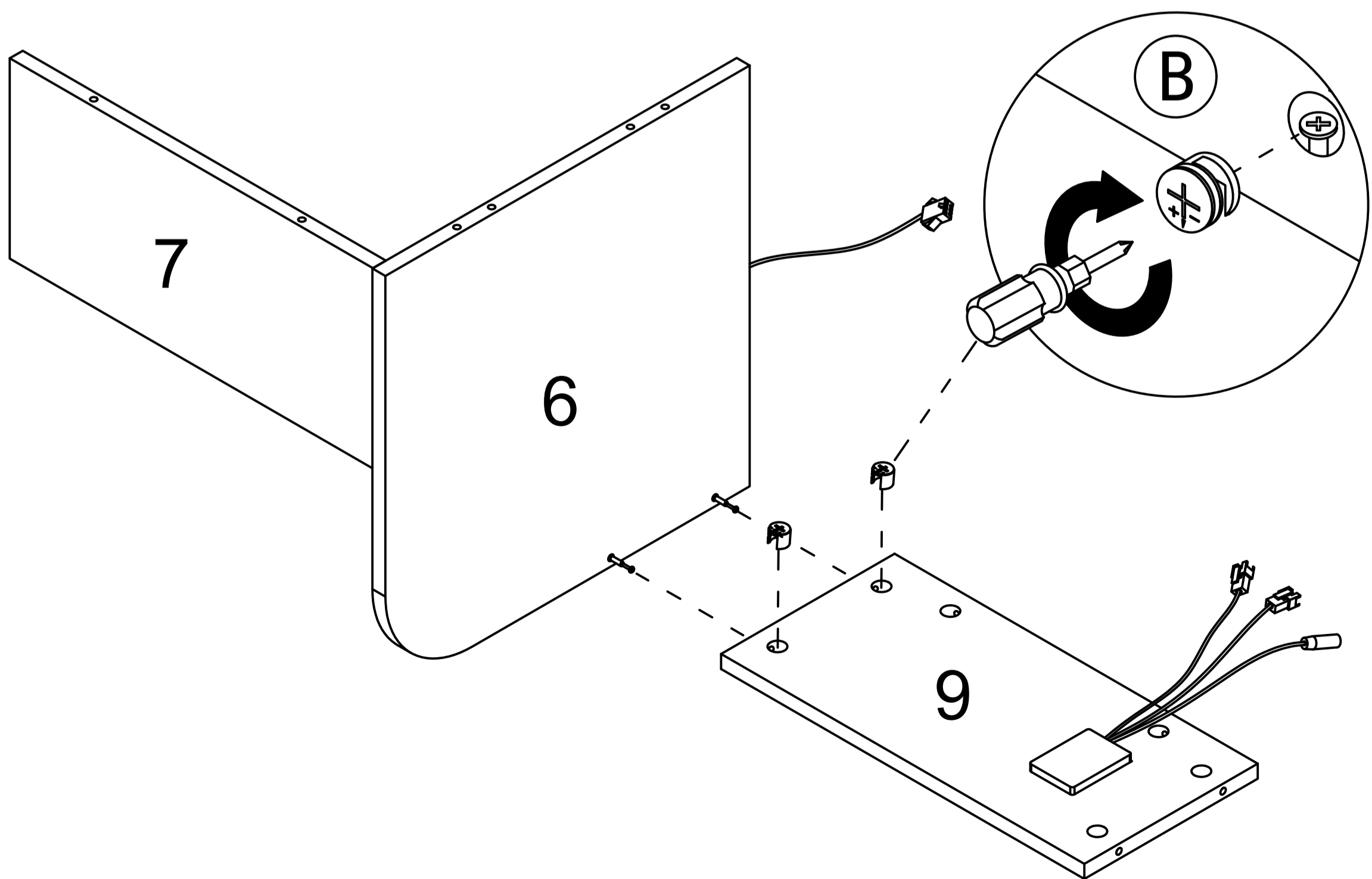

Step 16

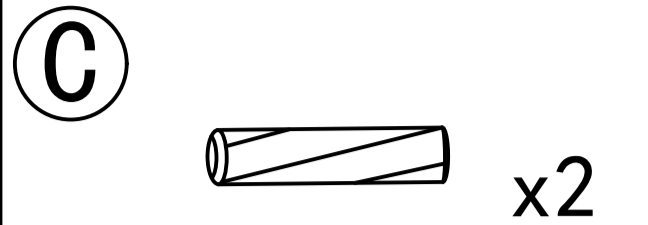
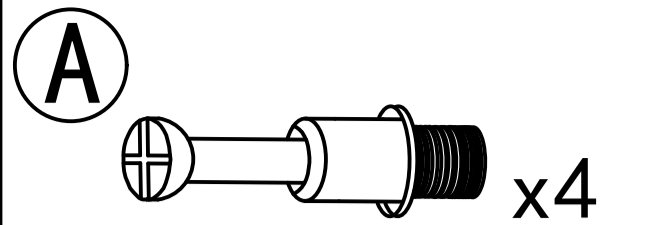
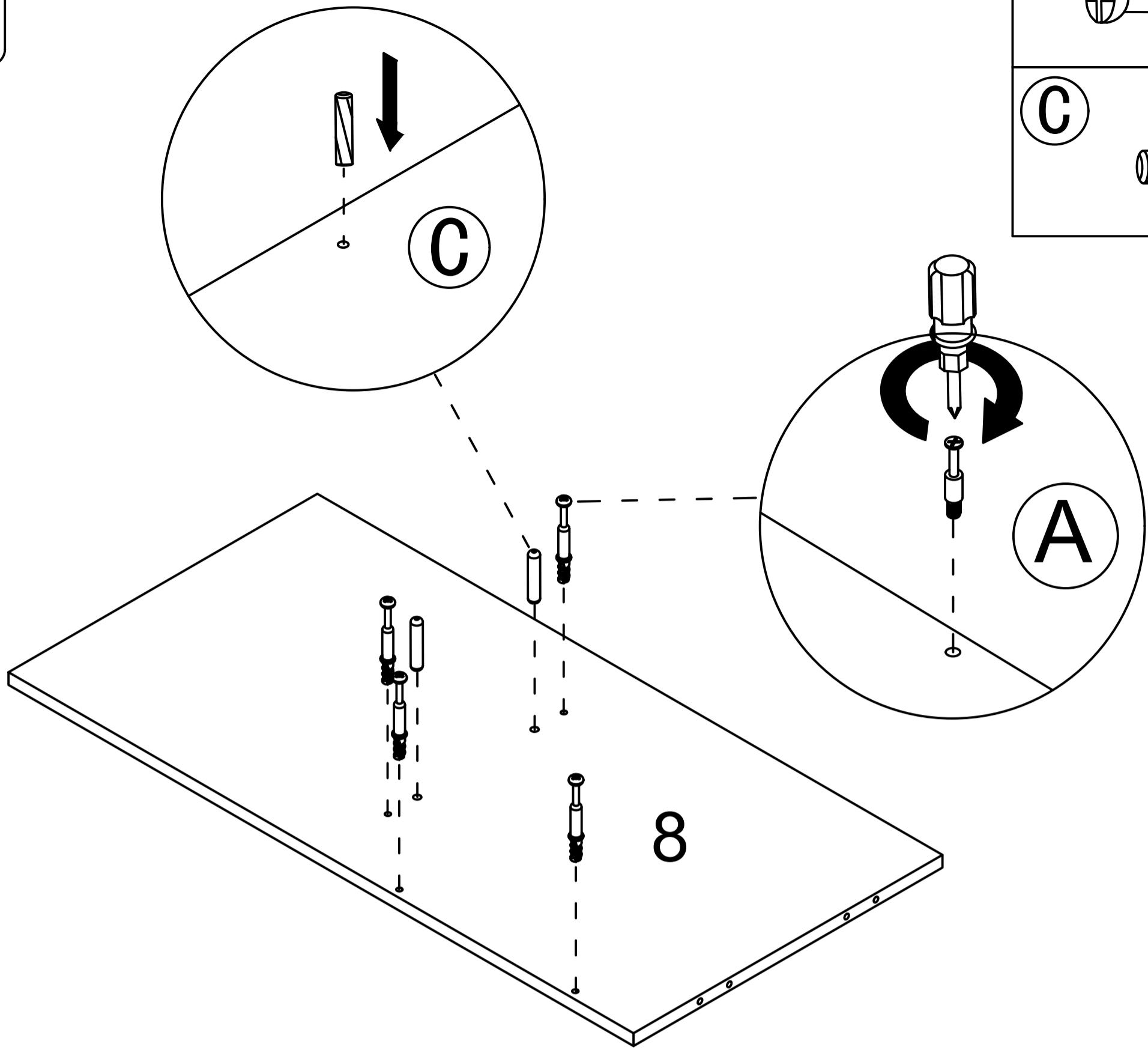

Step 17

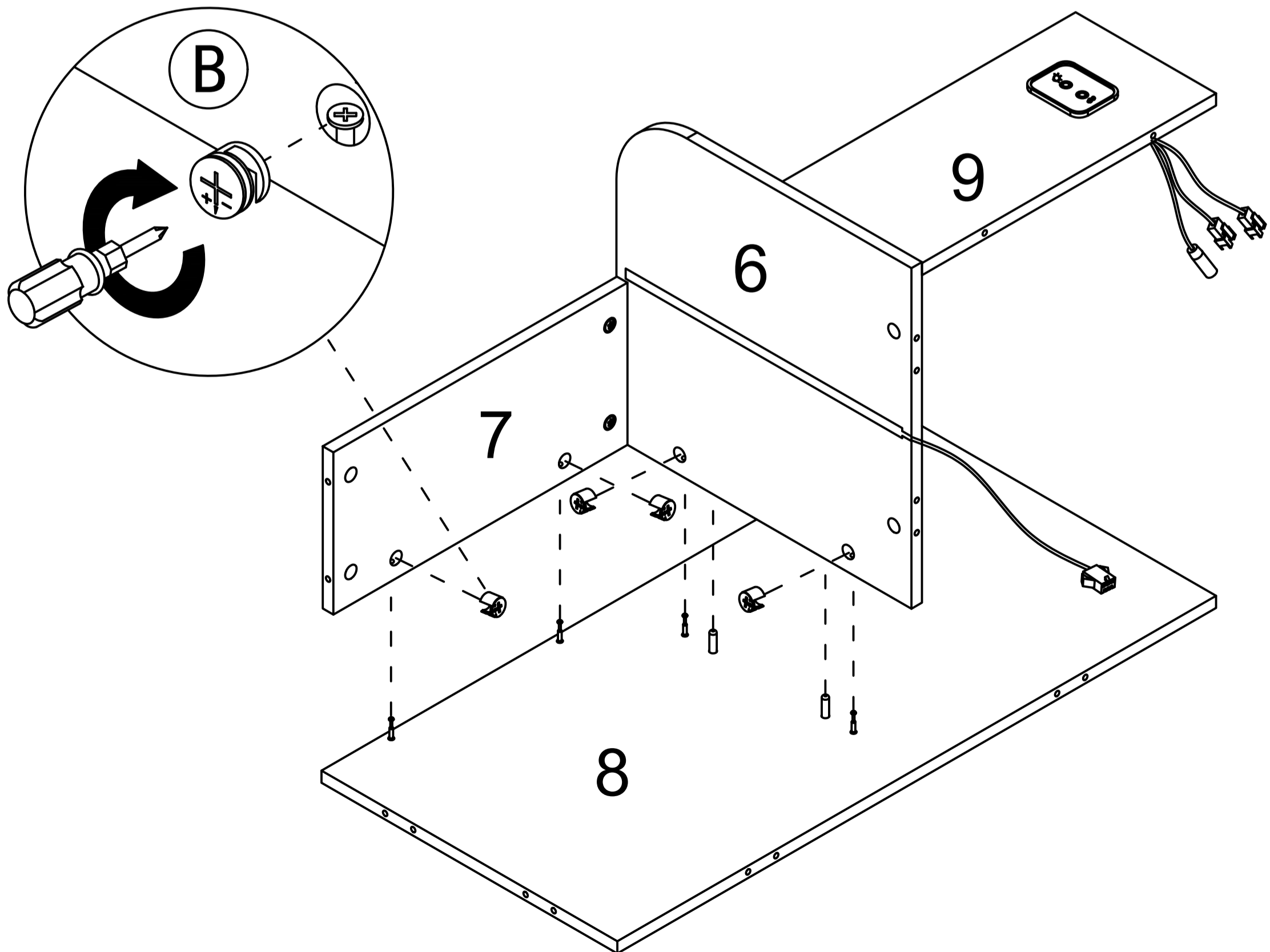

Step 18

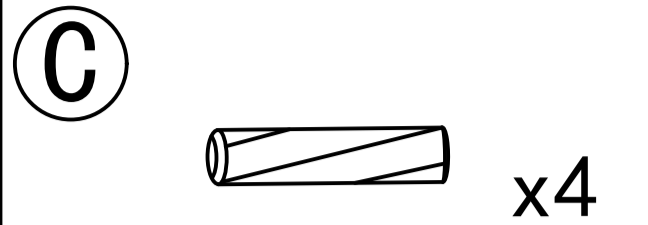
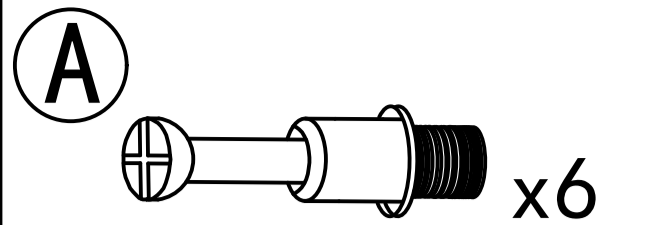
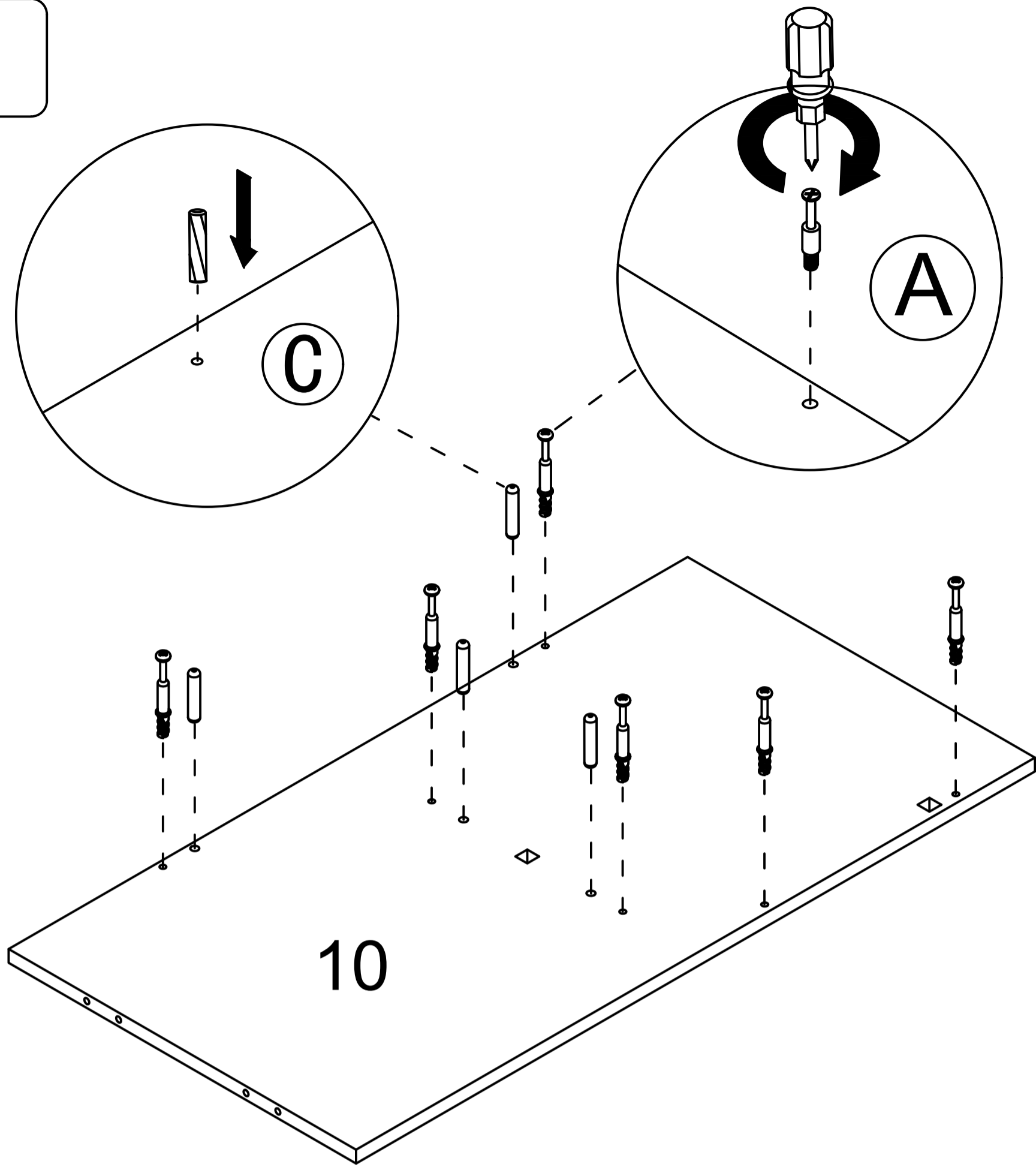

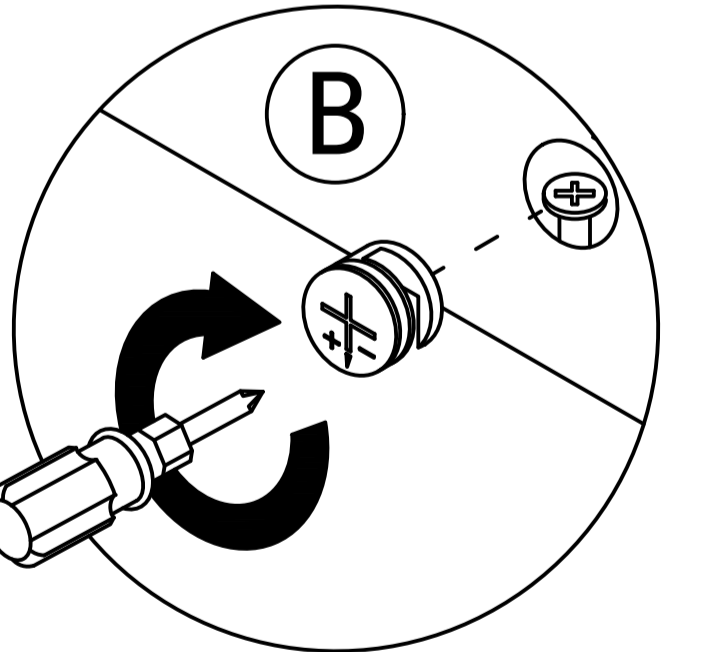
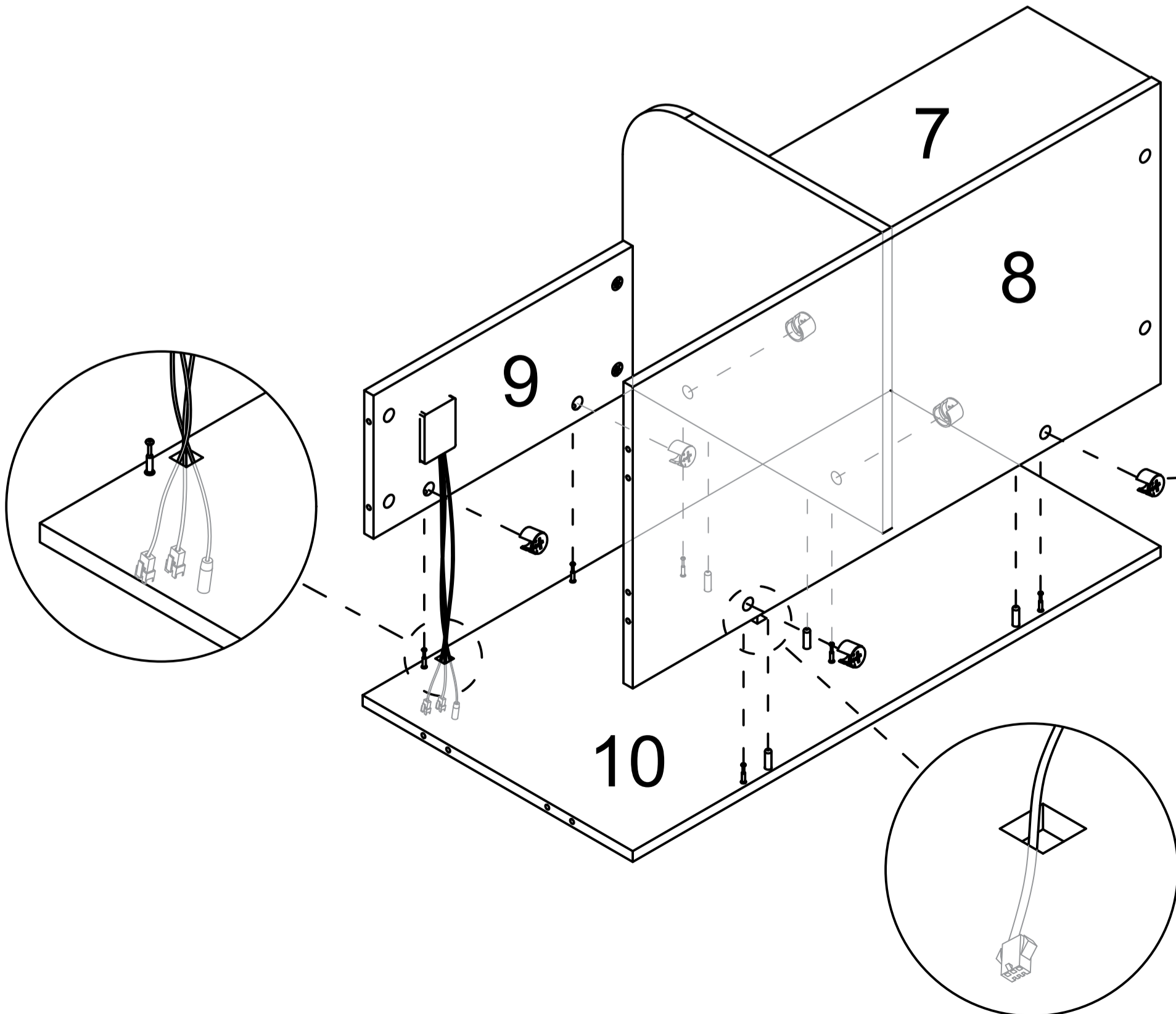

Step 19

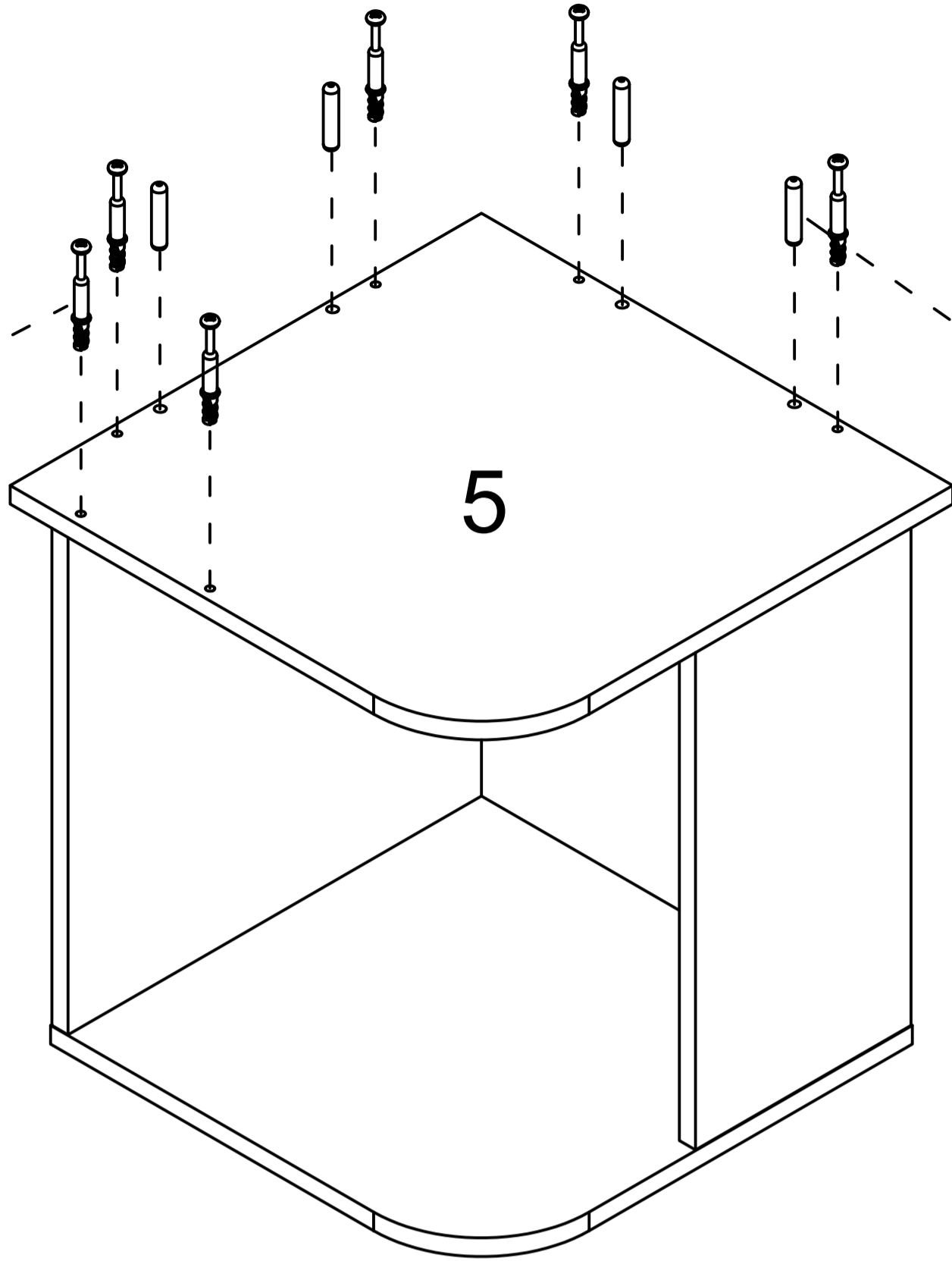
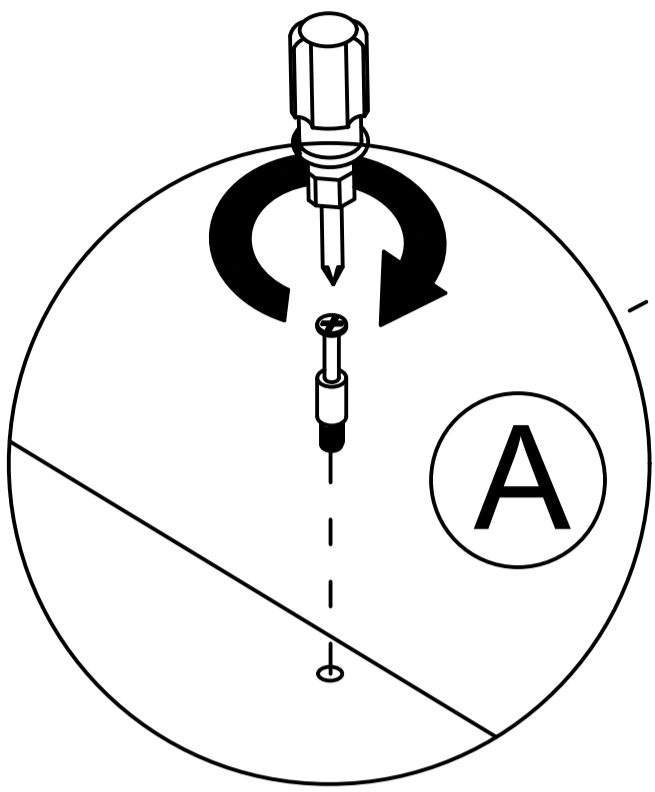

Step 20

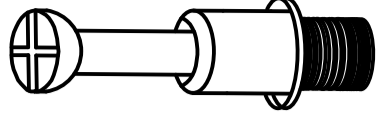

- (A)  x6
- (C)  x4

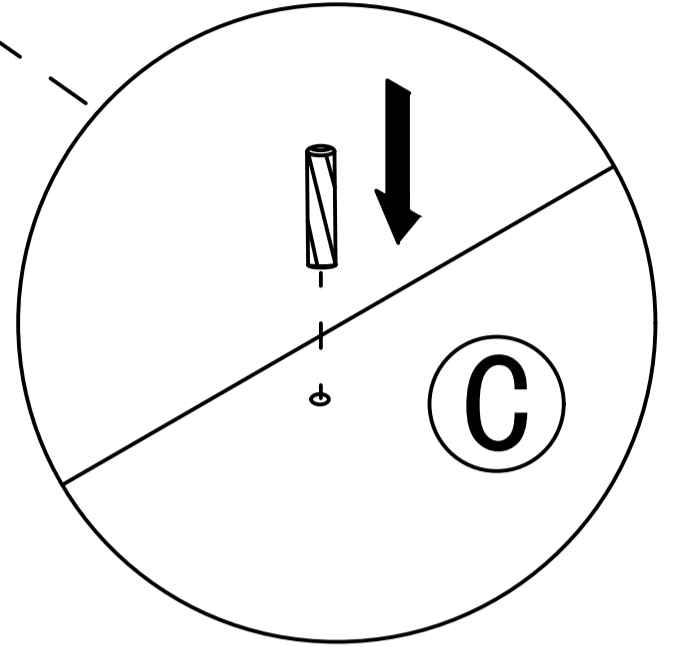

Step 21

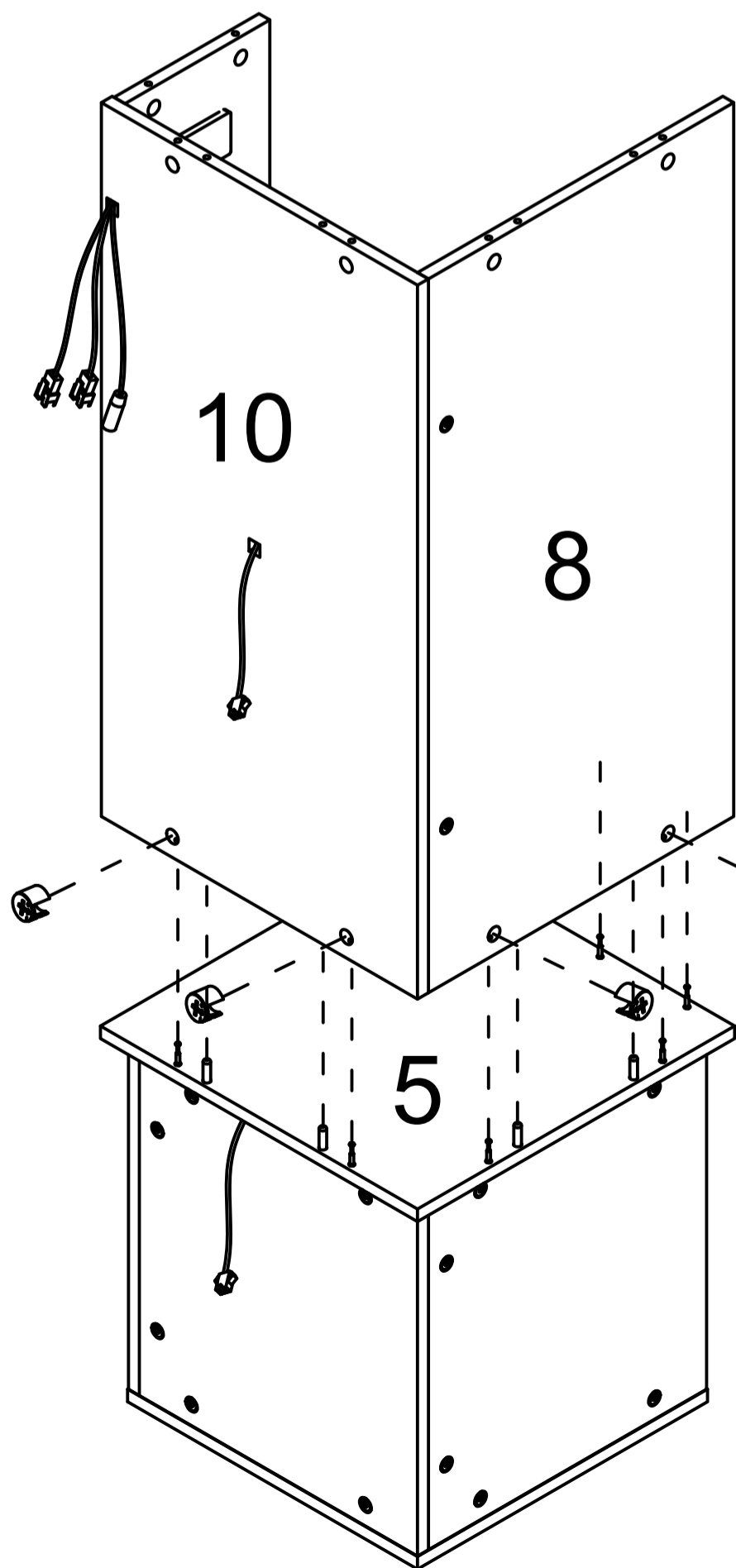

- (B)  x4

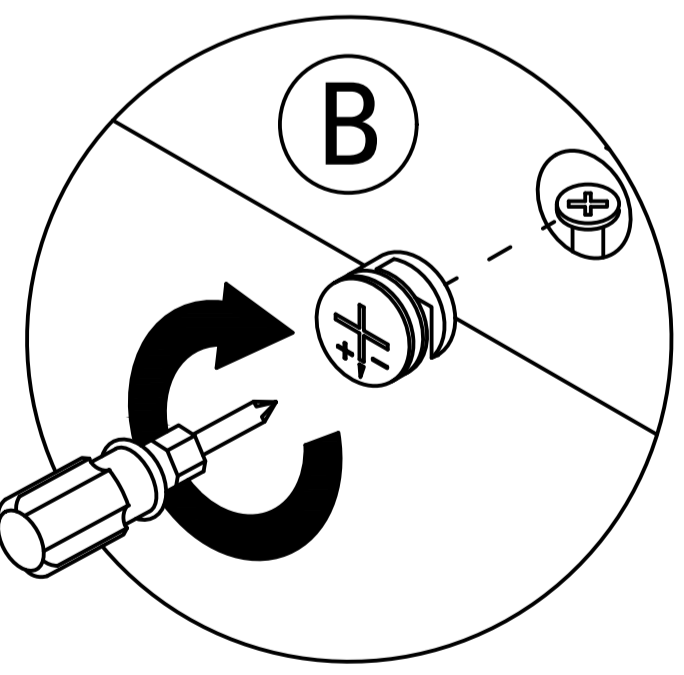

Step 22

B  x2

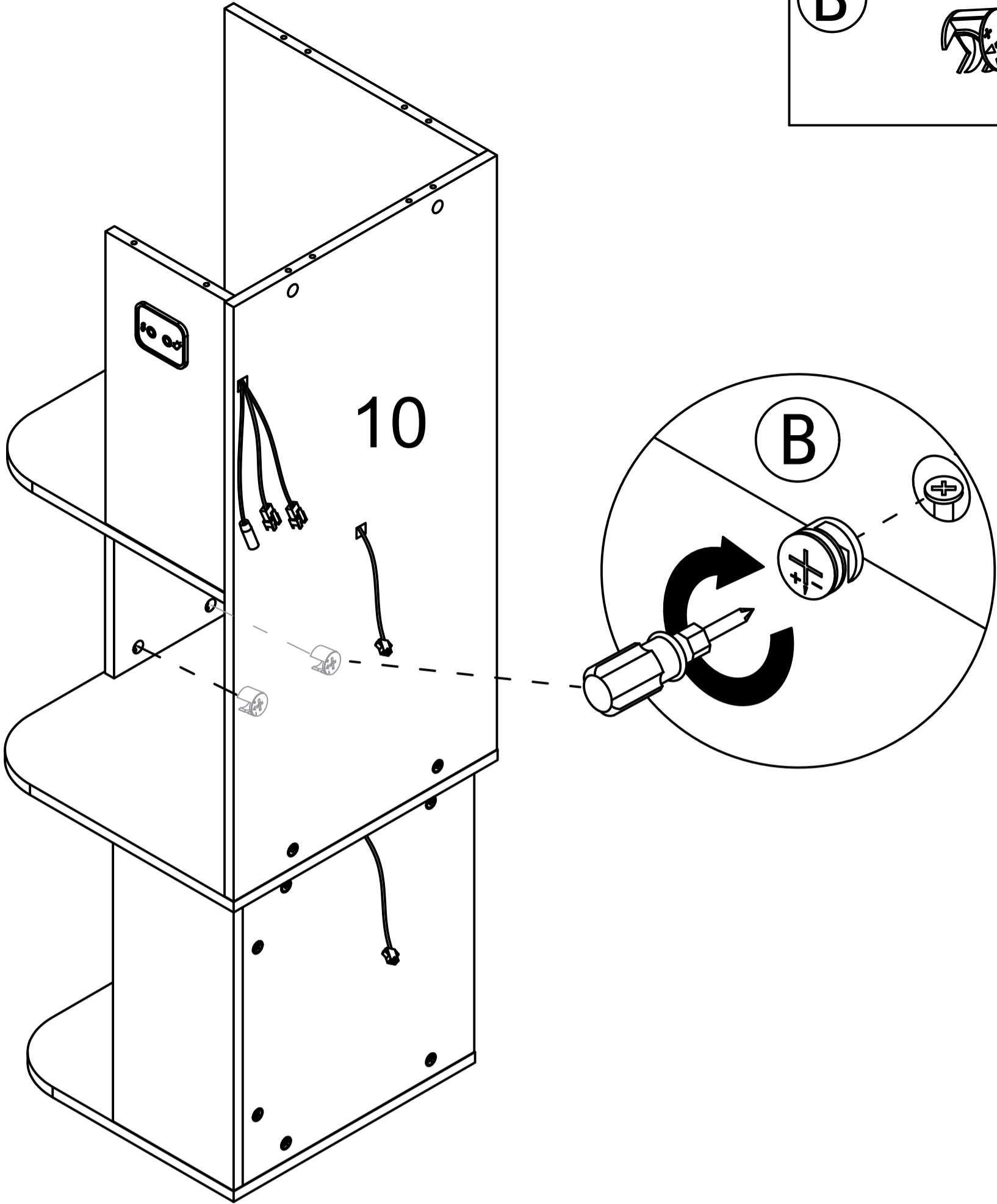

Step 23

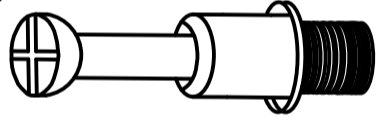
A  x6

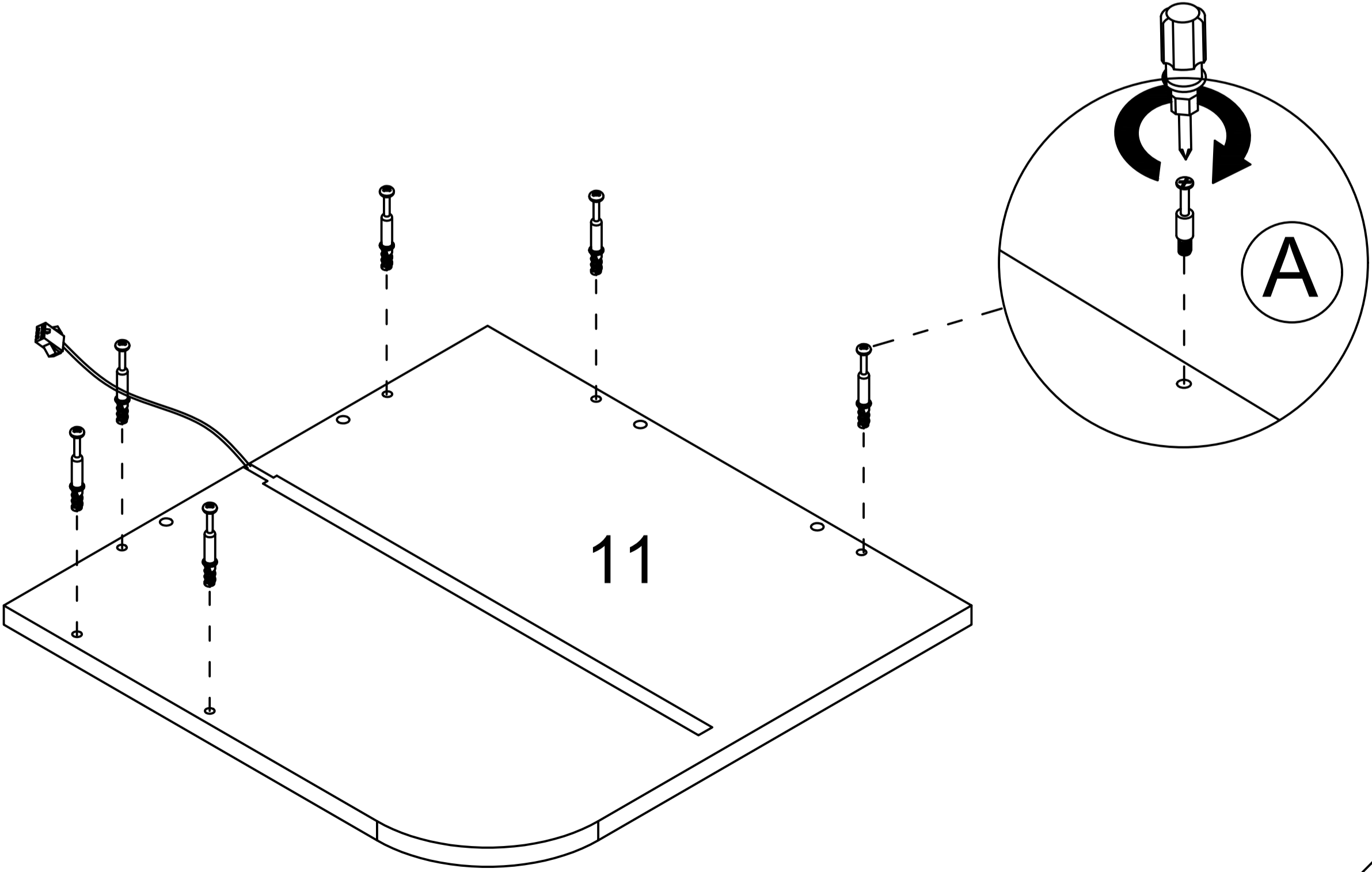

Step 24

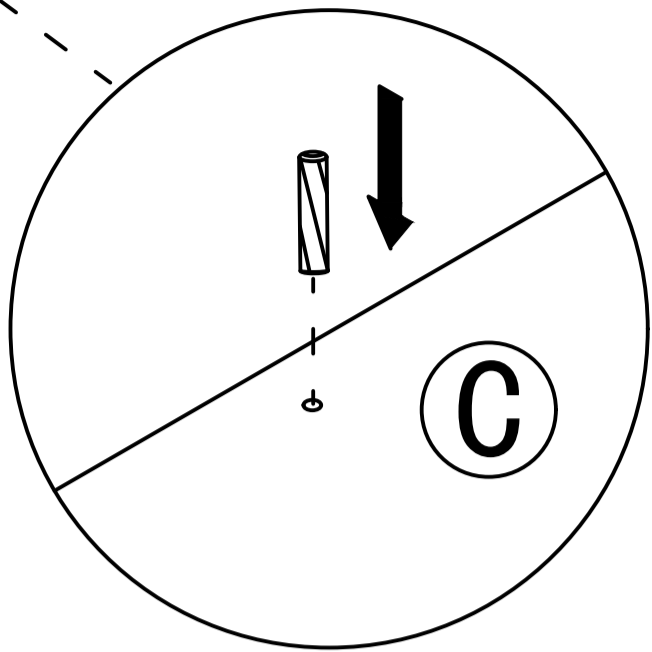
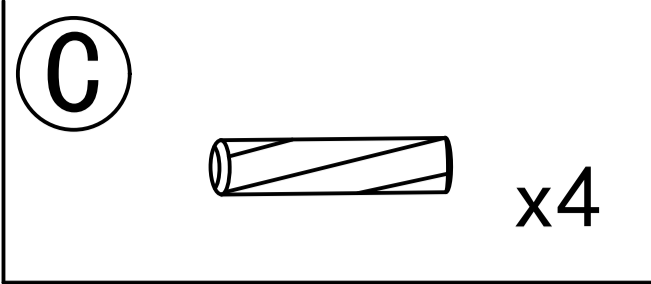
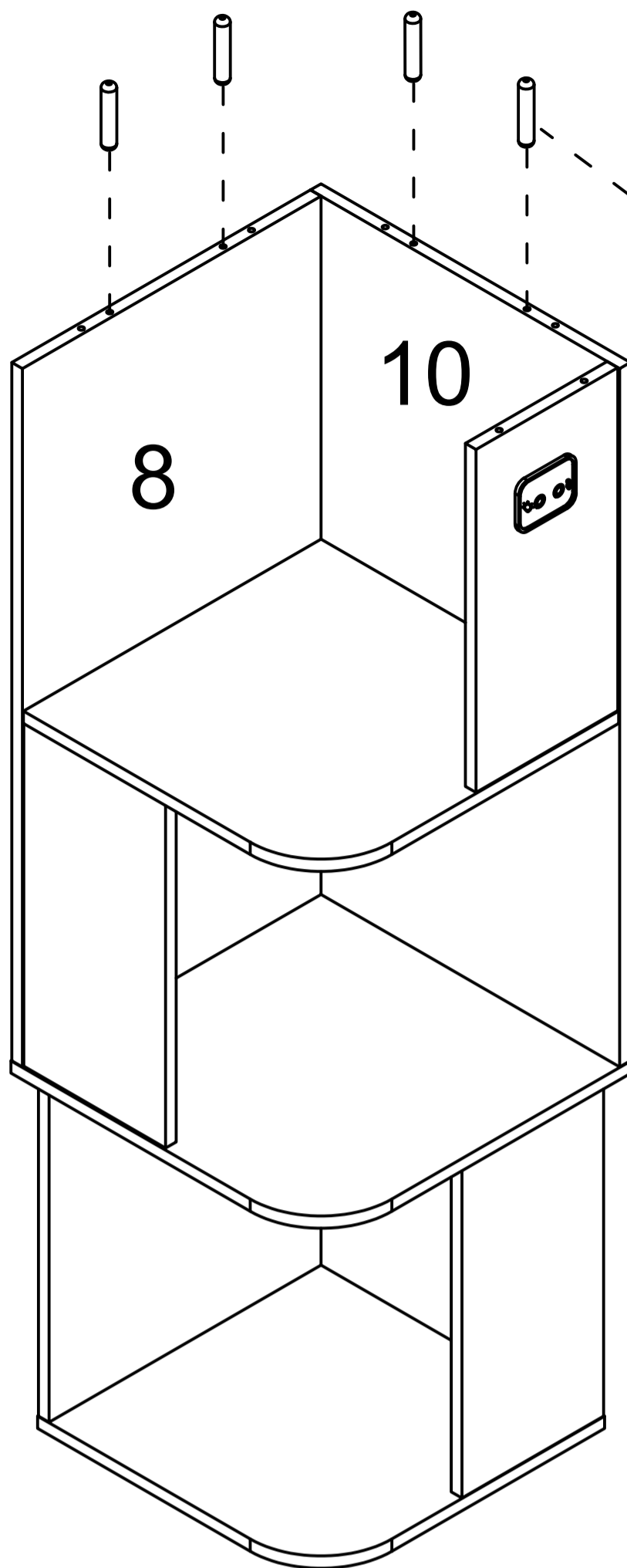

Step 25

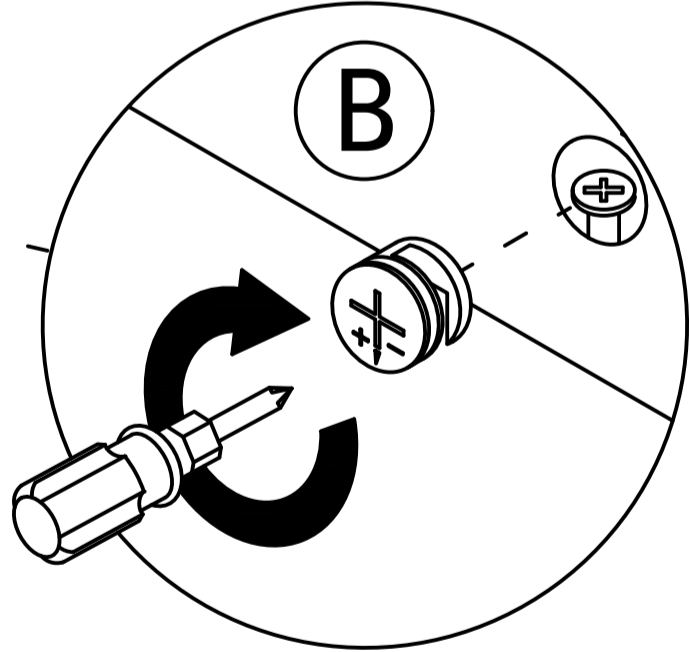
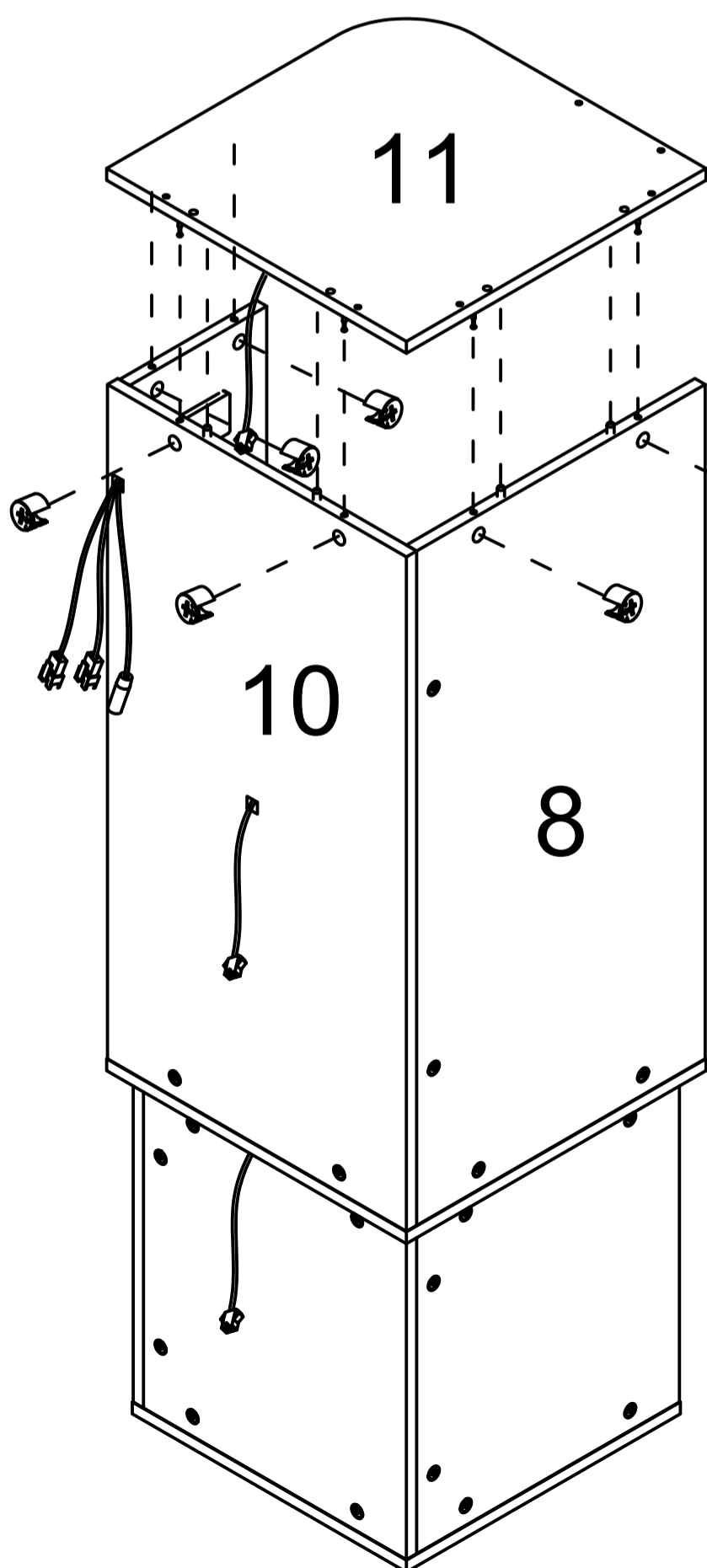

Step 26

B  x2

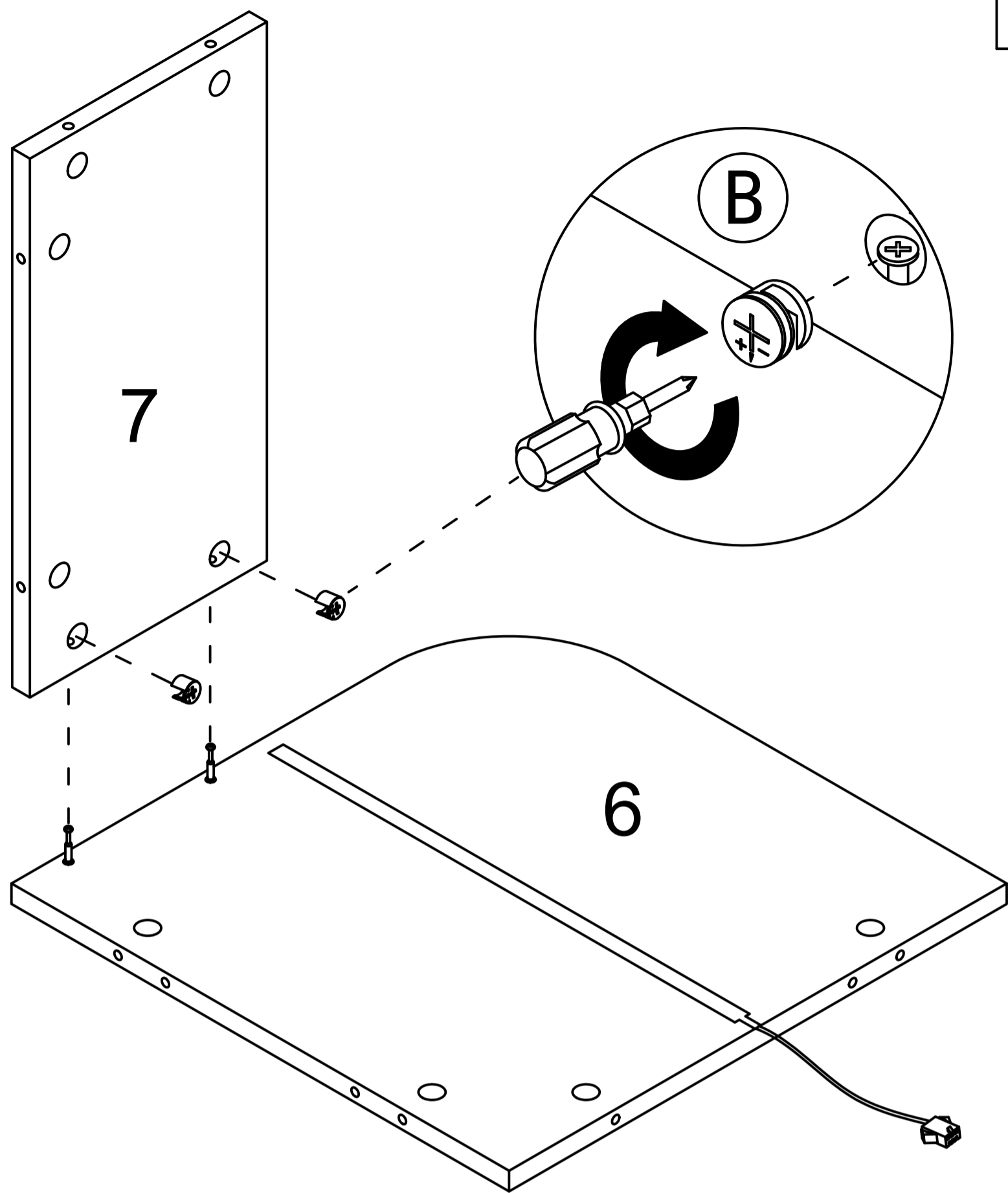

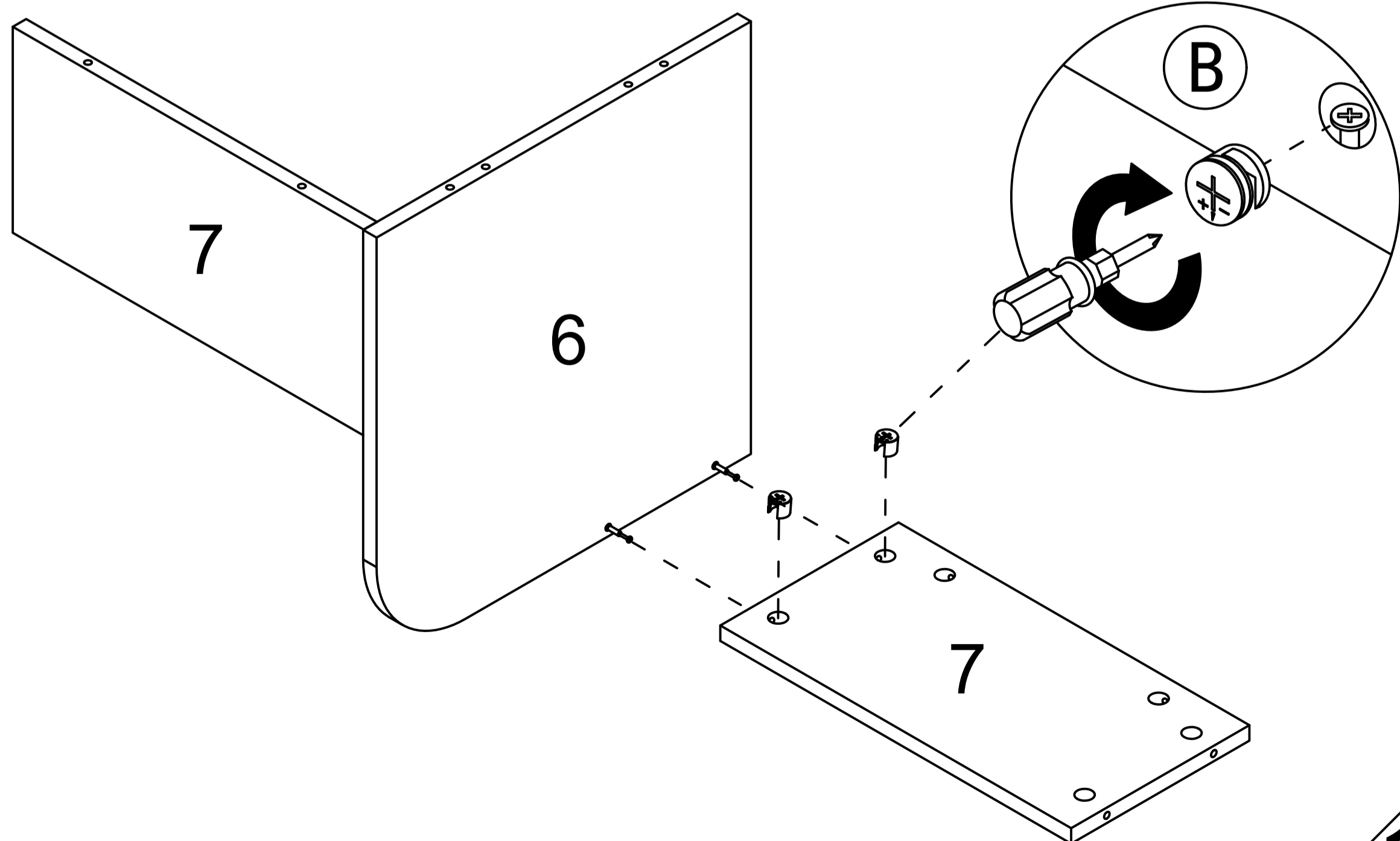

Step 27

B  x2

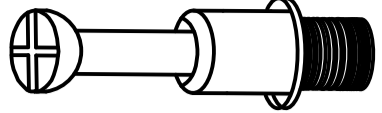

Step 28

- A**  x4
- C**  x2

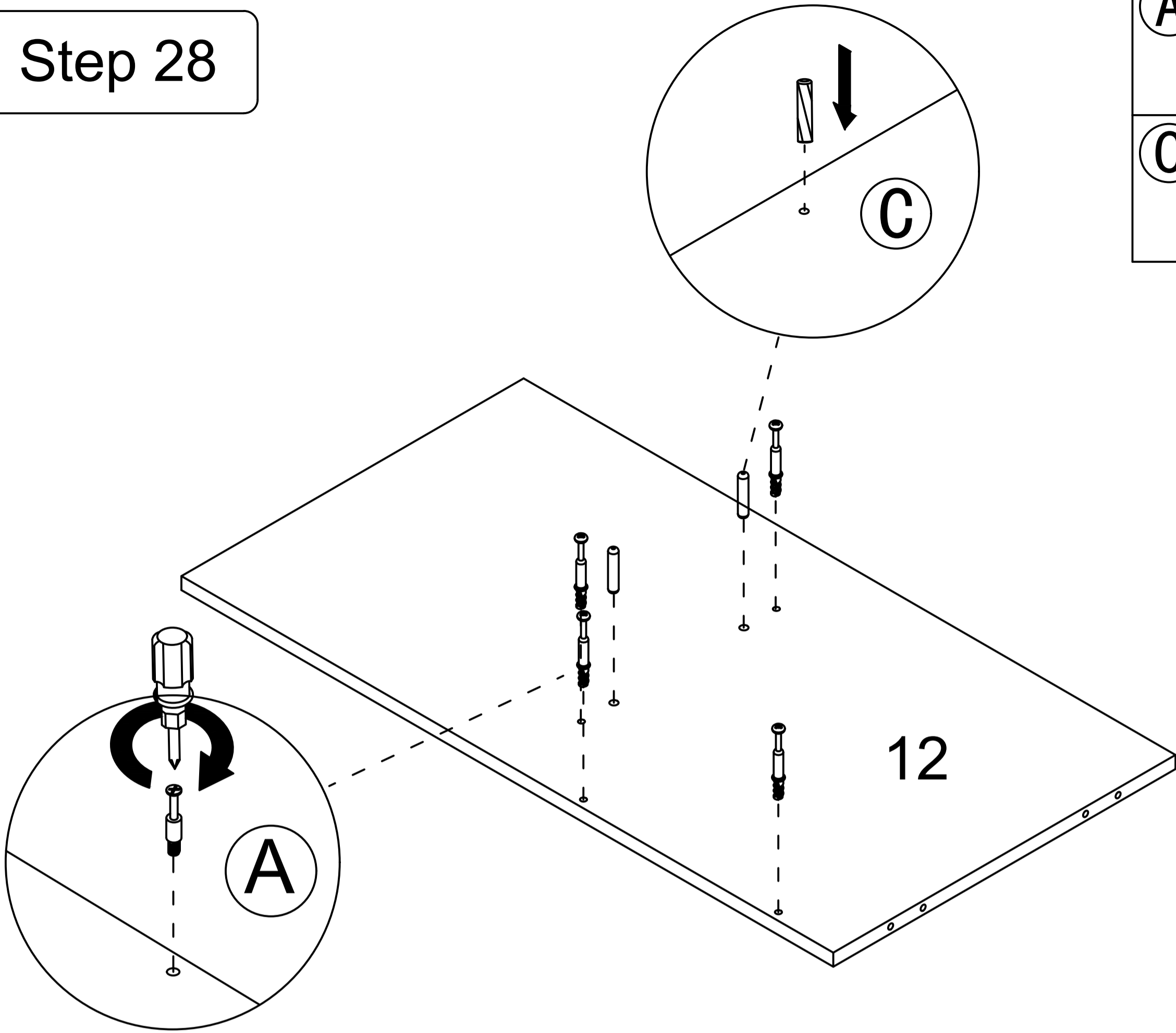

Step 29

- B**  x4

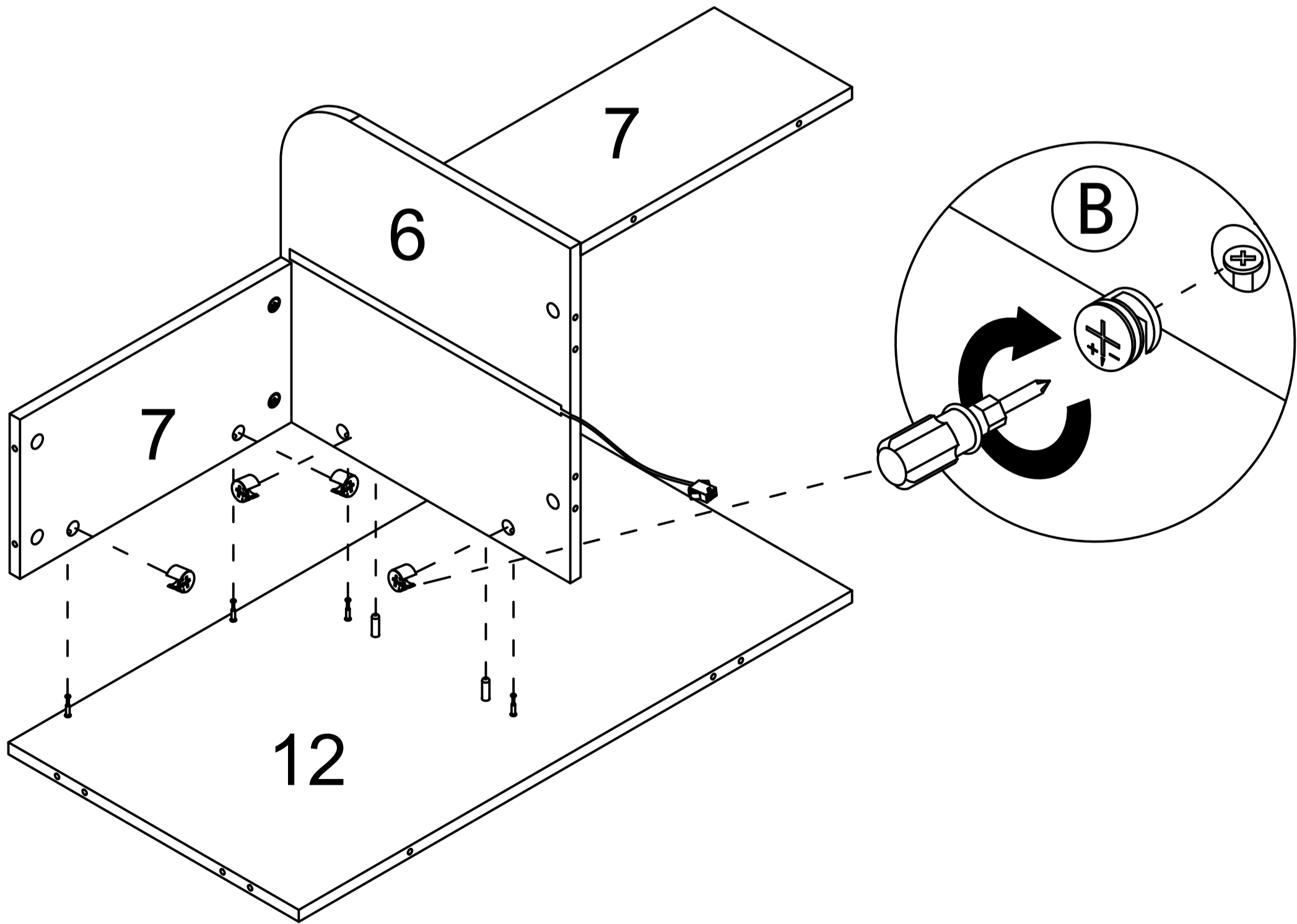

Step 30

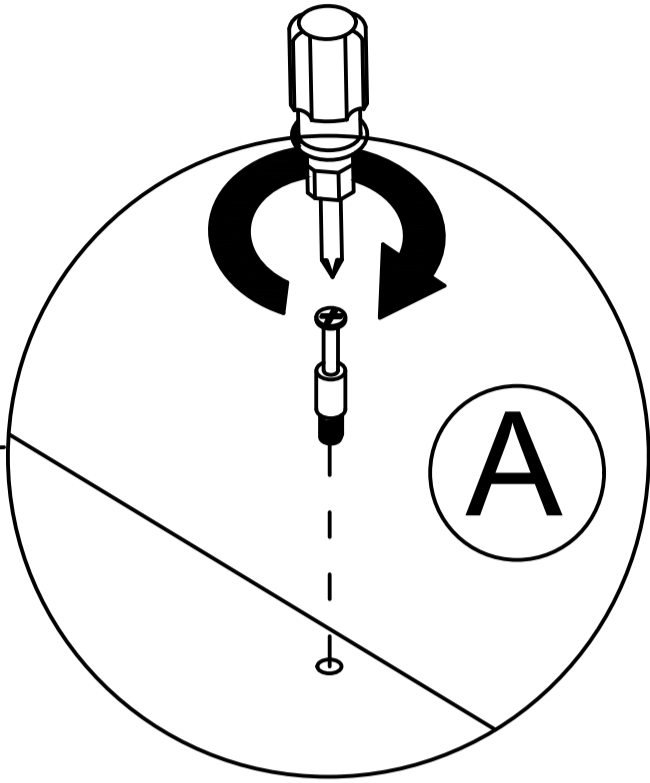
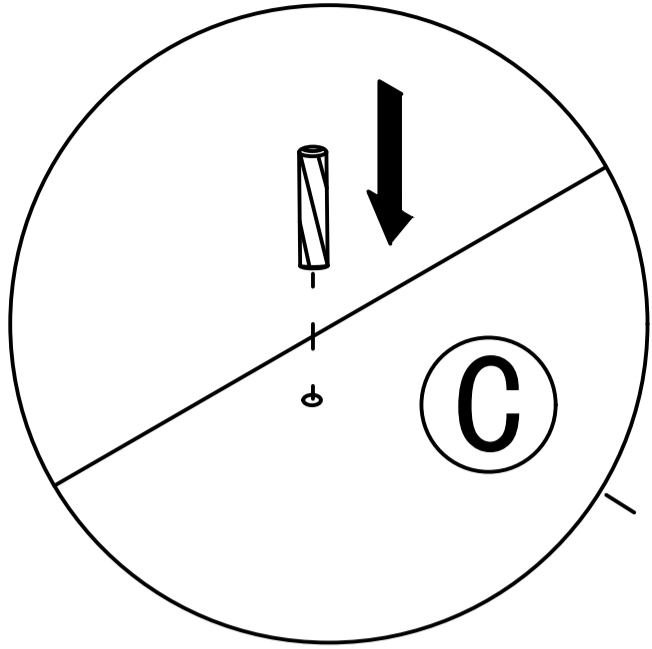
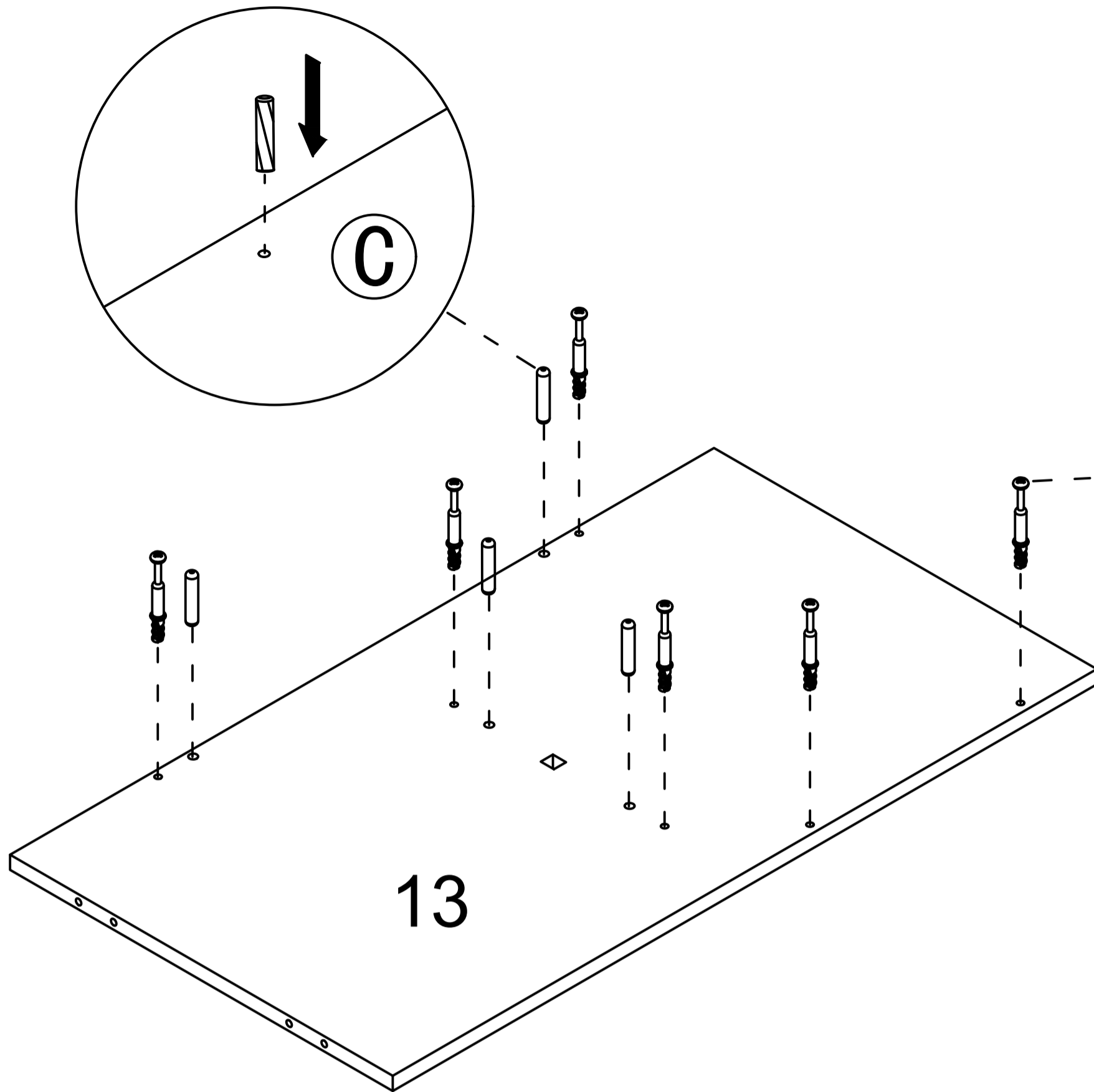

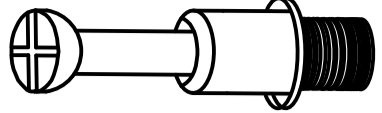
(A)  x6

(C)  x4

Step 31

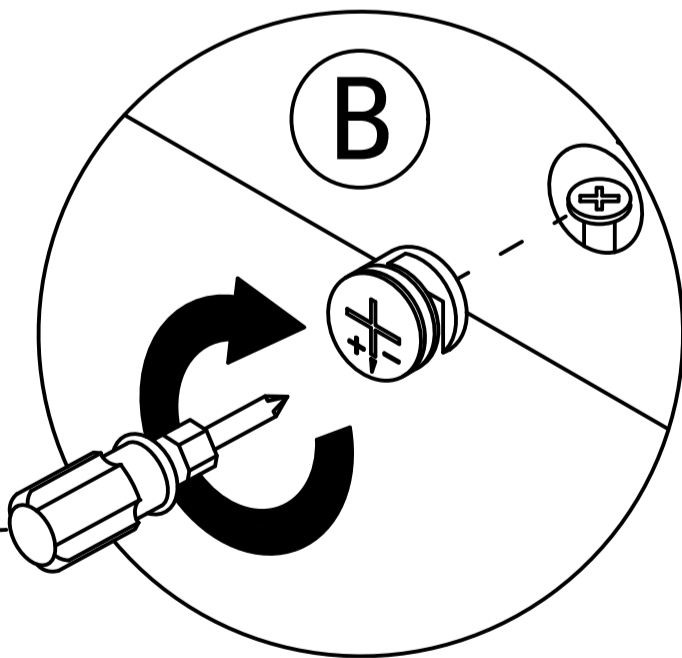
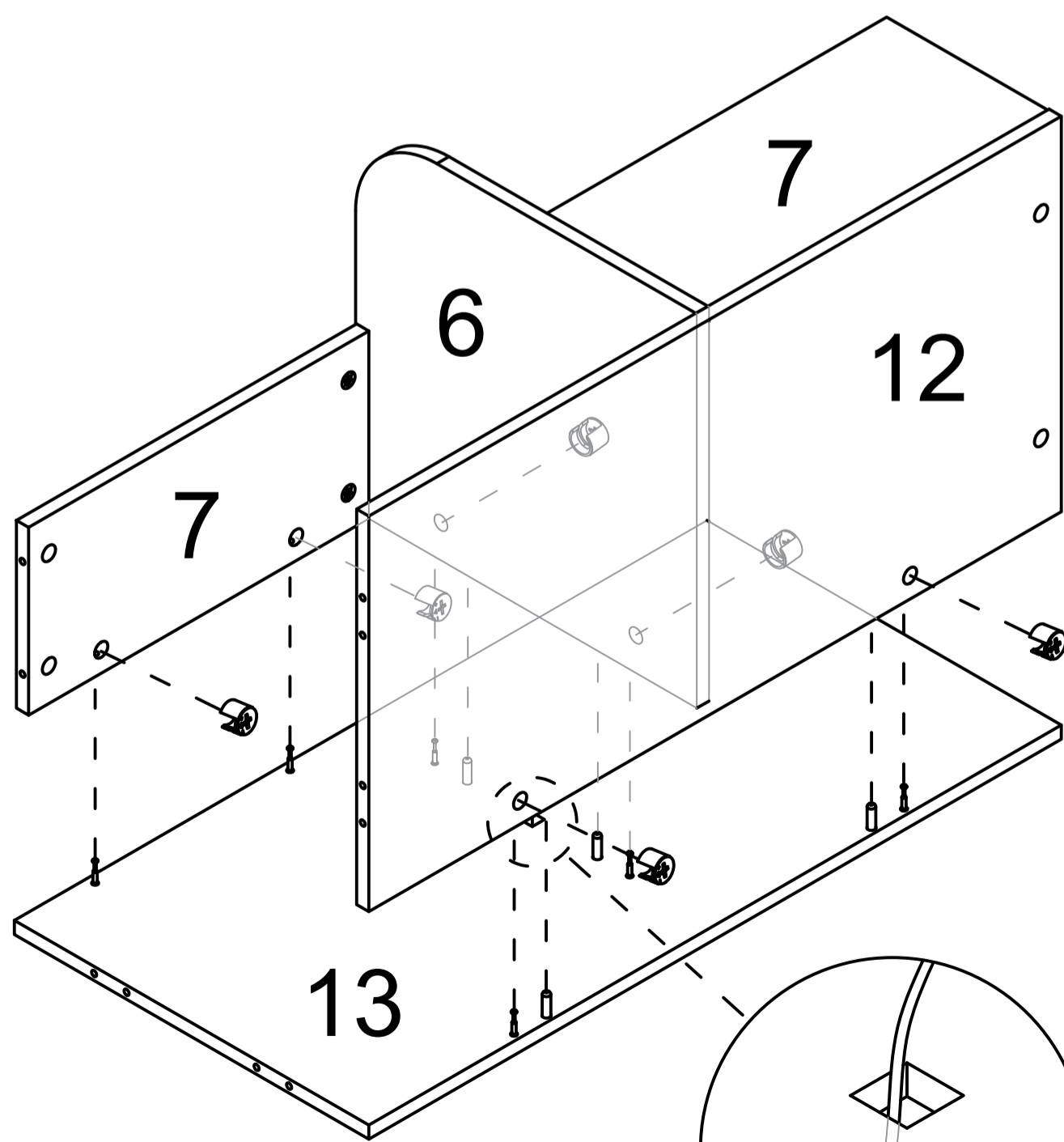

(B)  x6

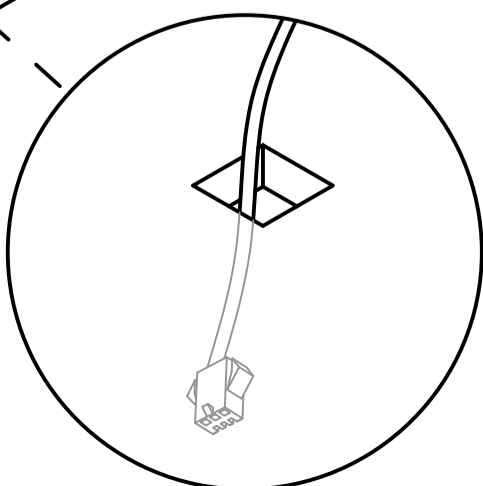

Step 32

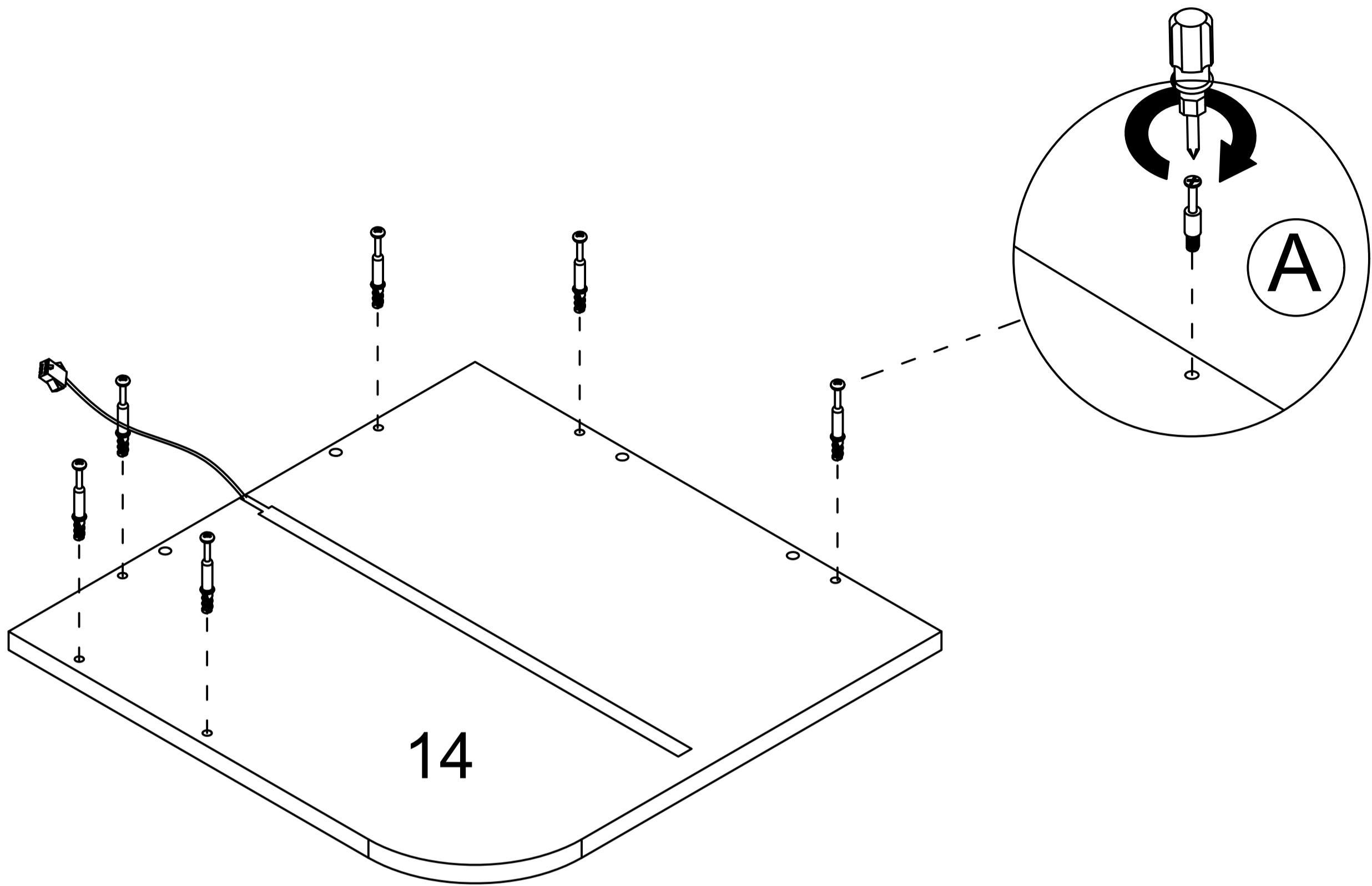
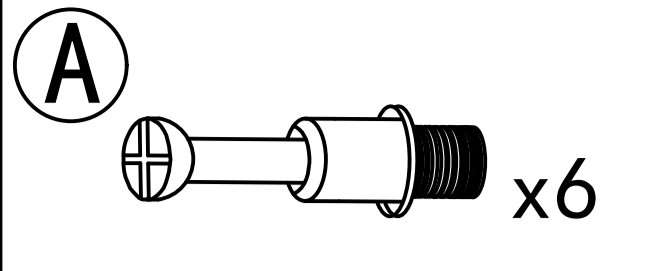

Step 33

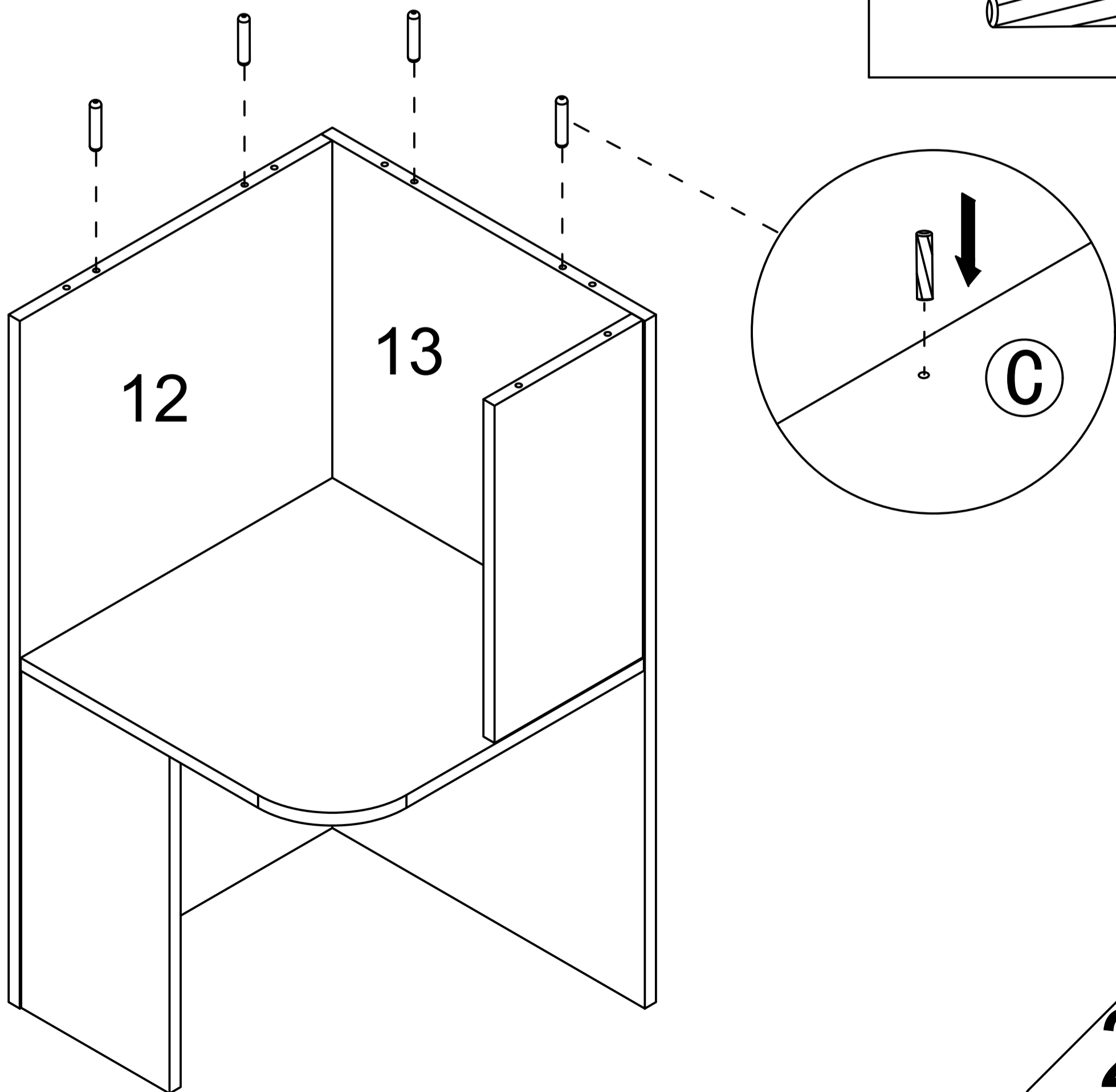
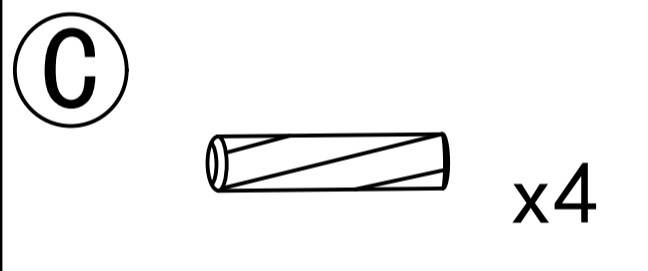

Step 34

B  x6

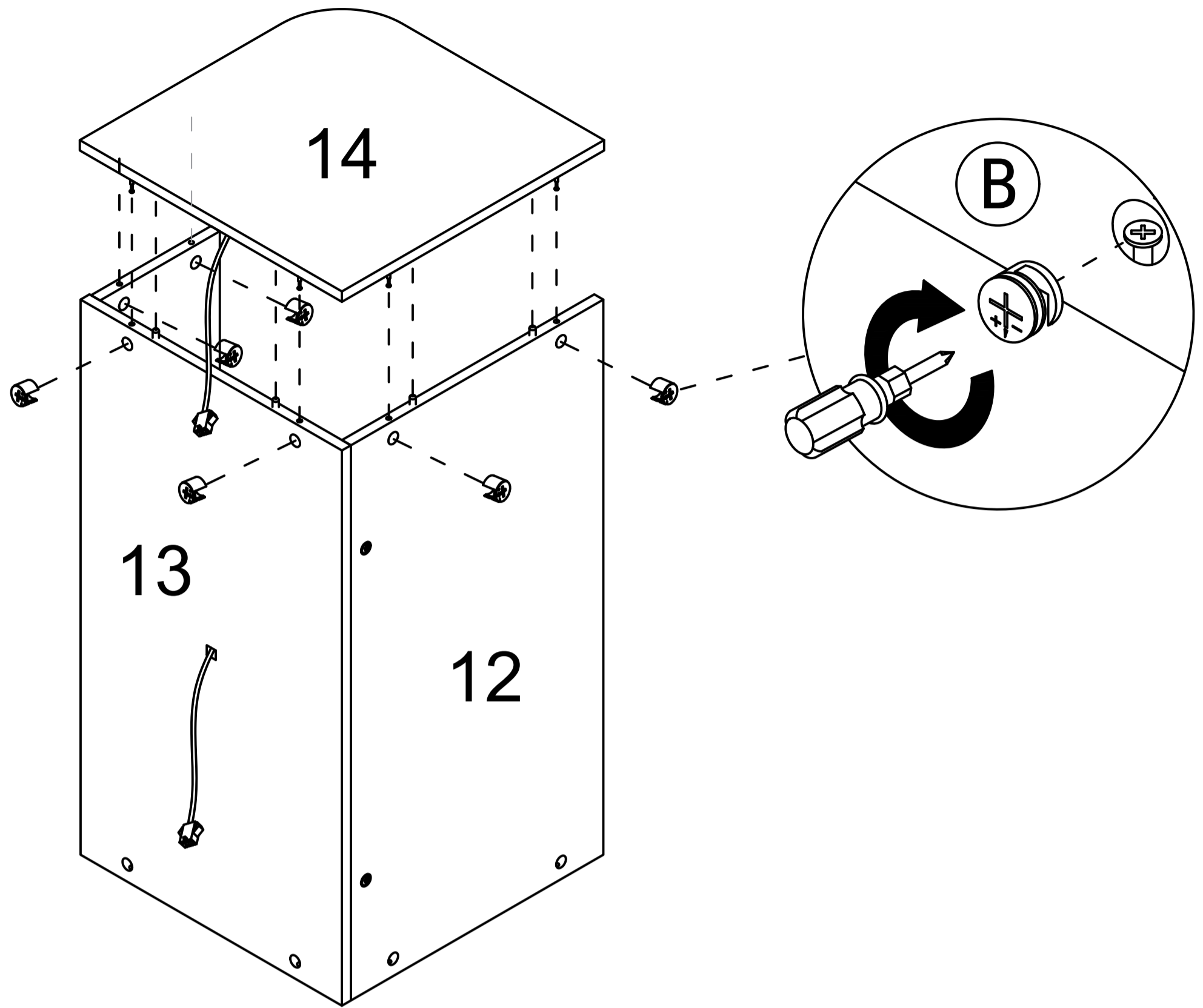

Step 35

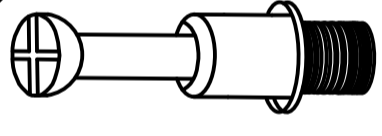
A  x6

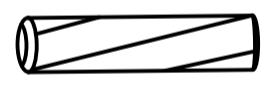
C  x4

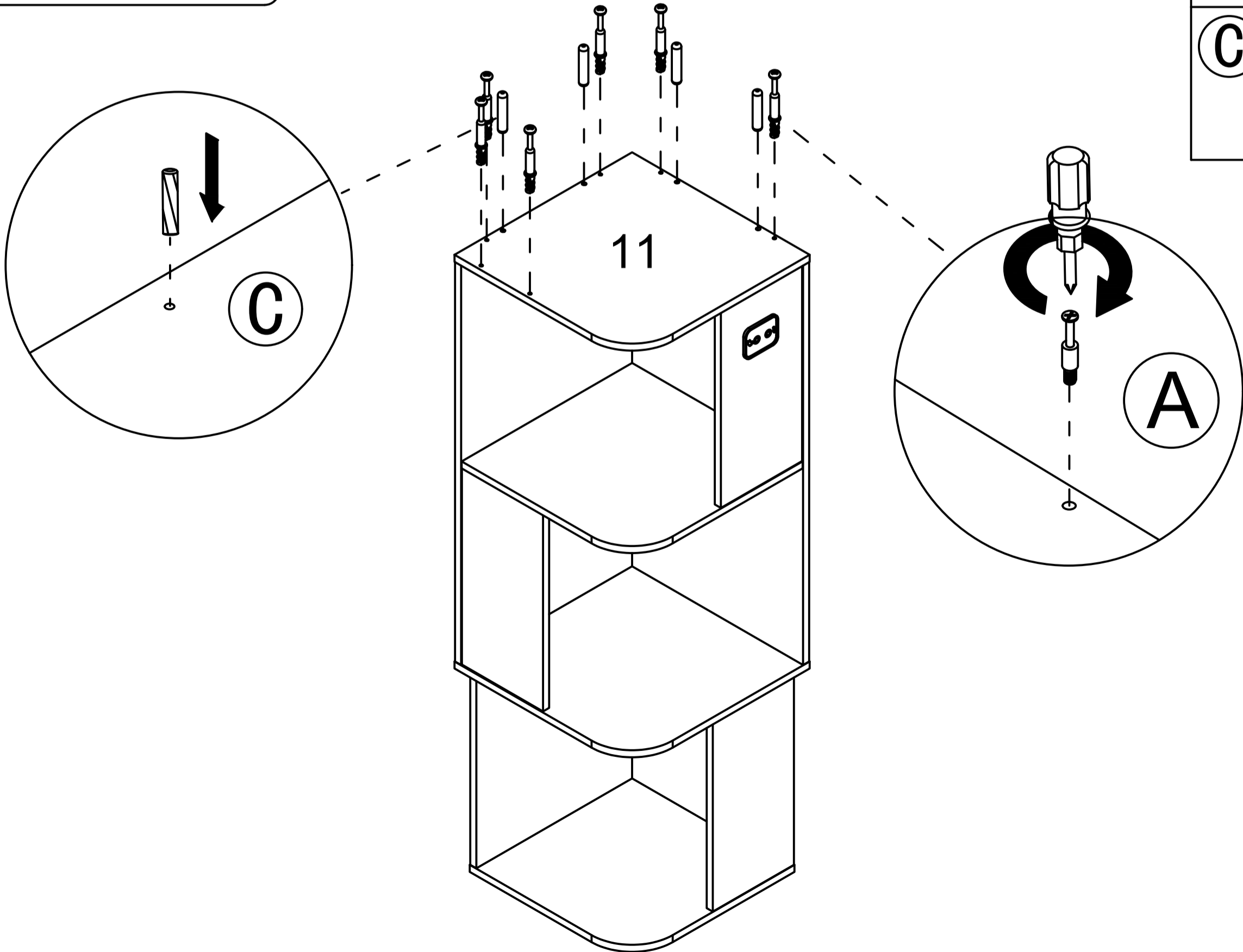

Step 36

(B)



x4

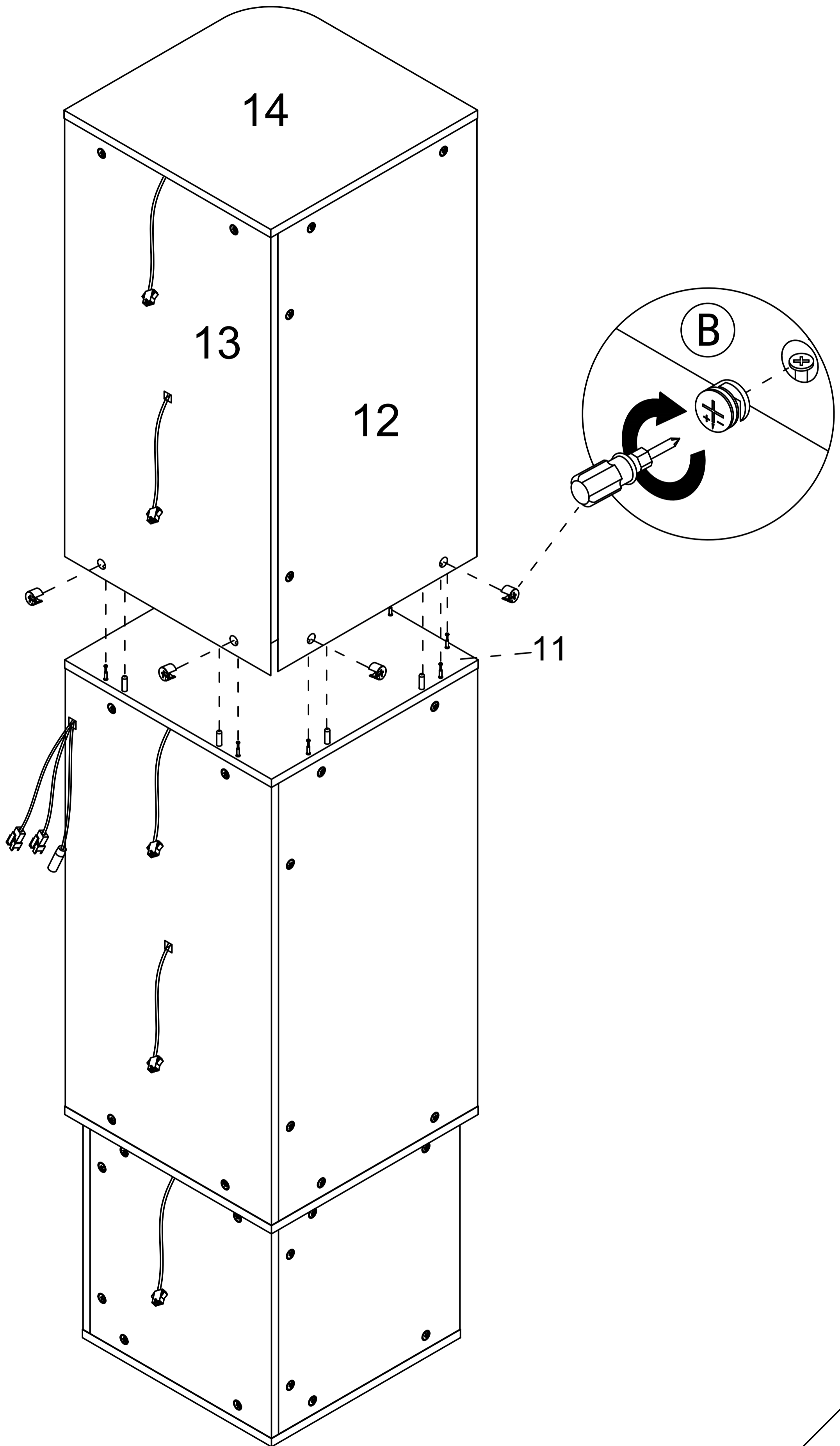

Step 37

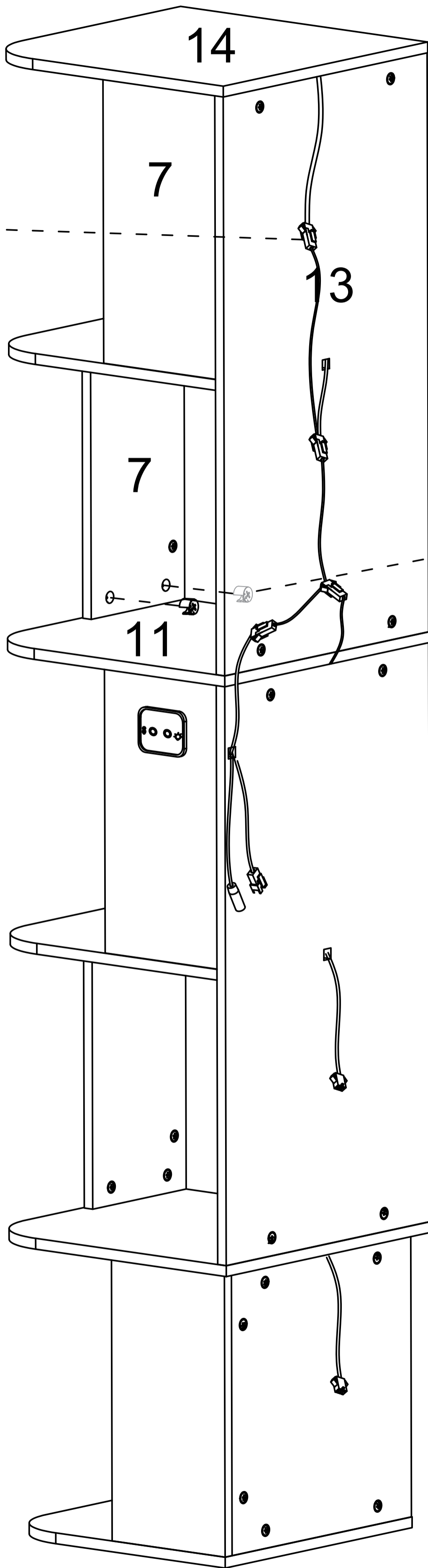
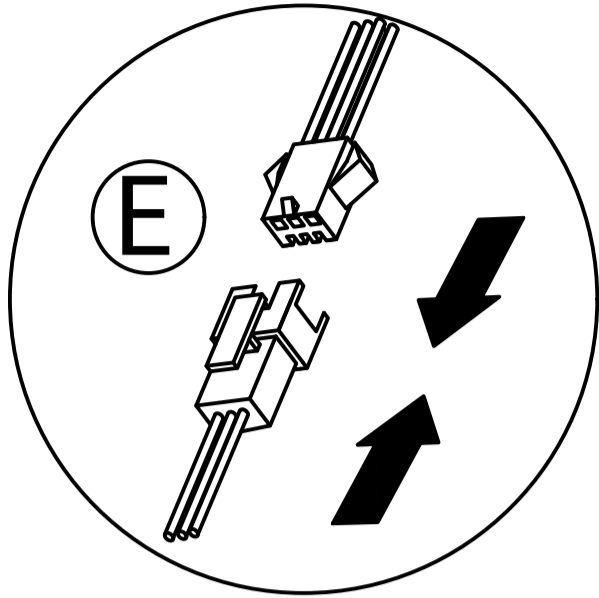

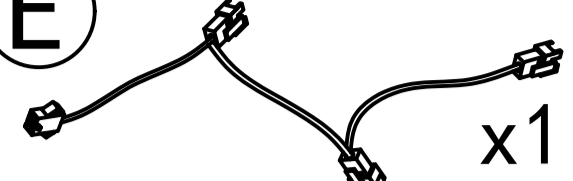
- (B)  x2
- (E)  x1

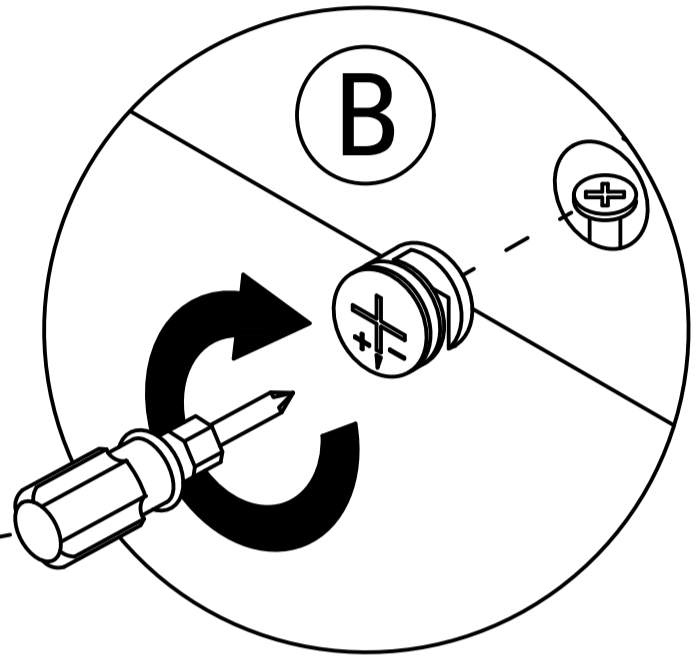

Step 38

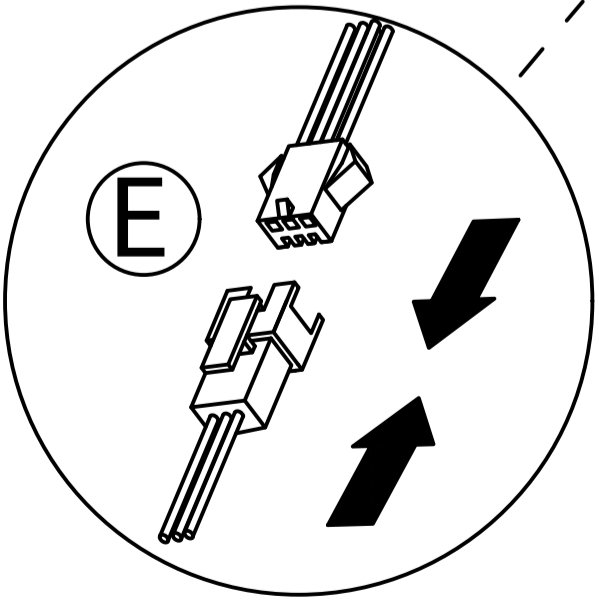
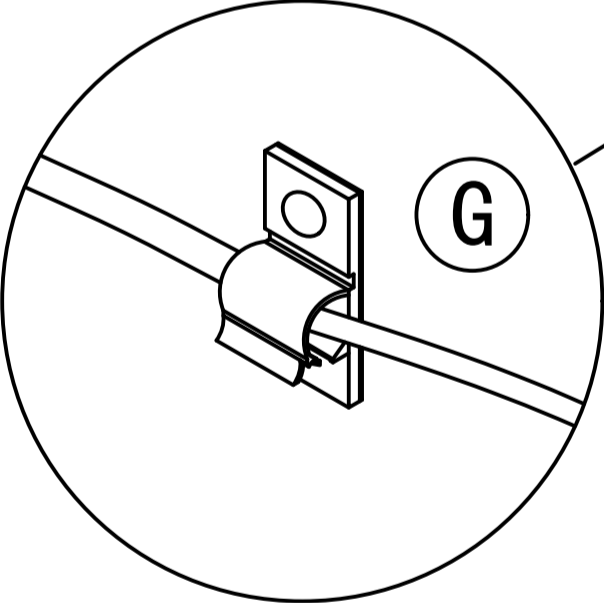
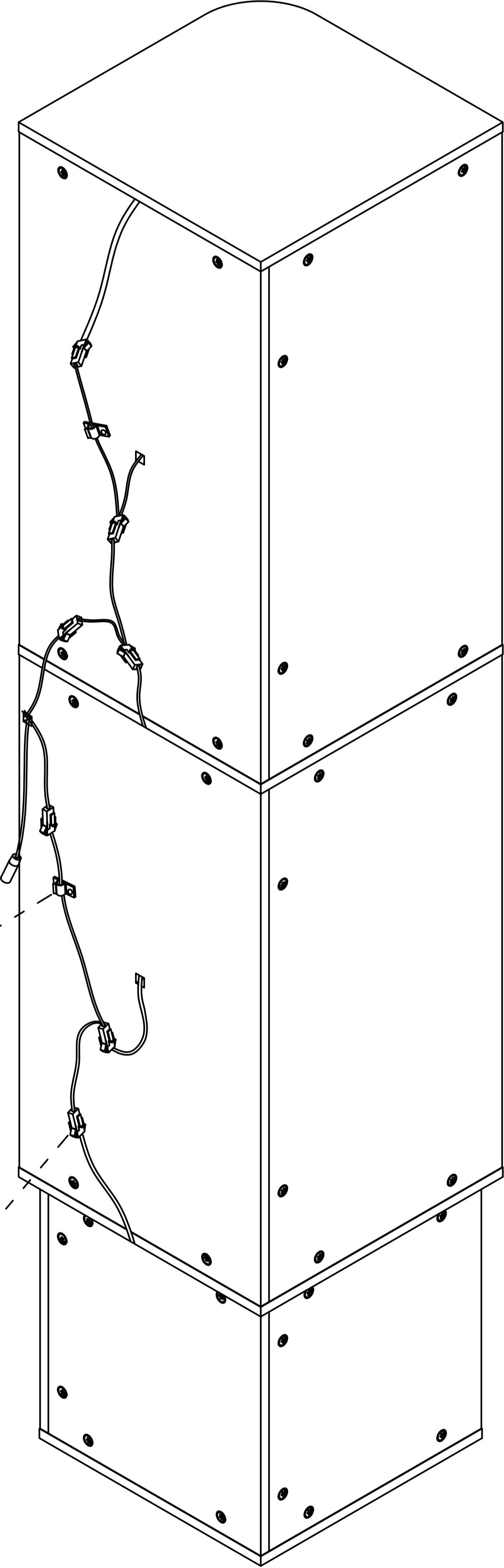
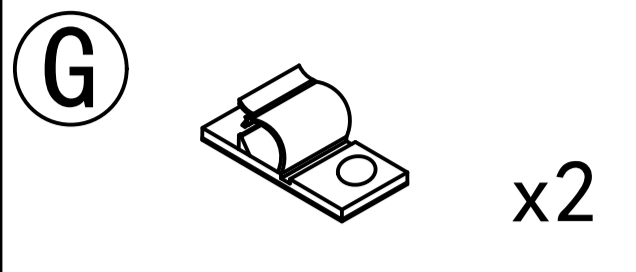
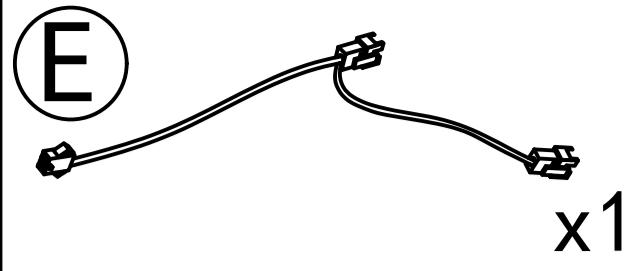

Step 39

Install as required

H

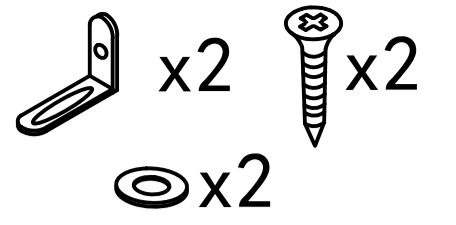

3.5x14mm

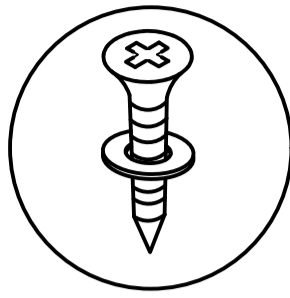

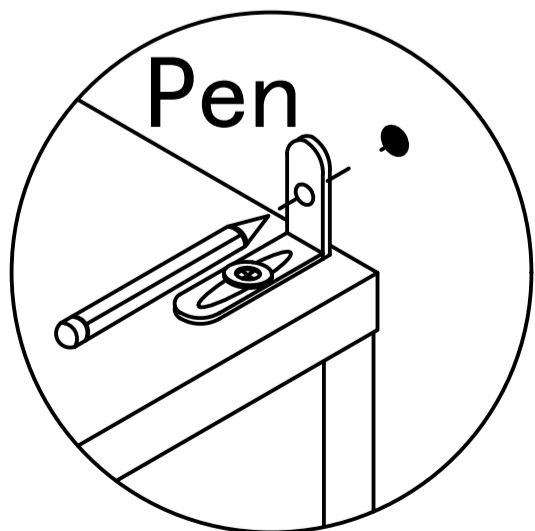
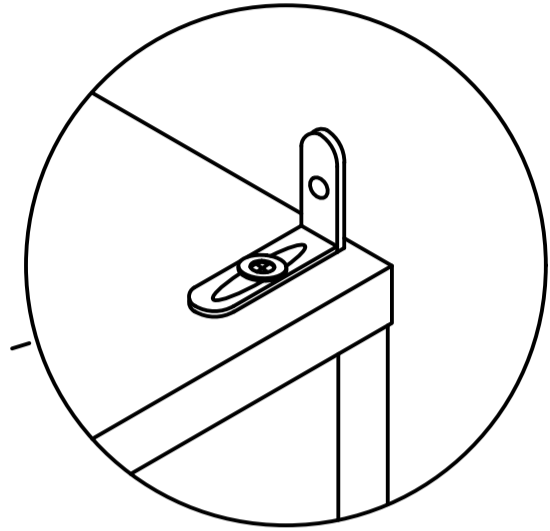
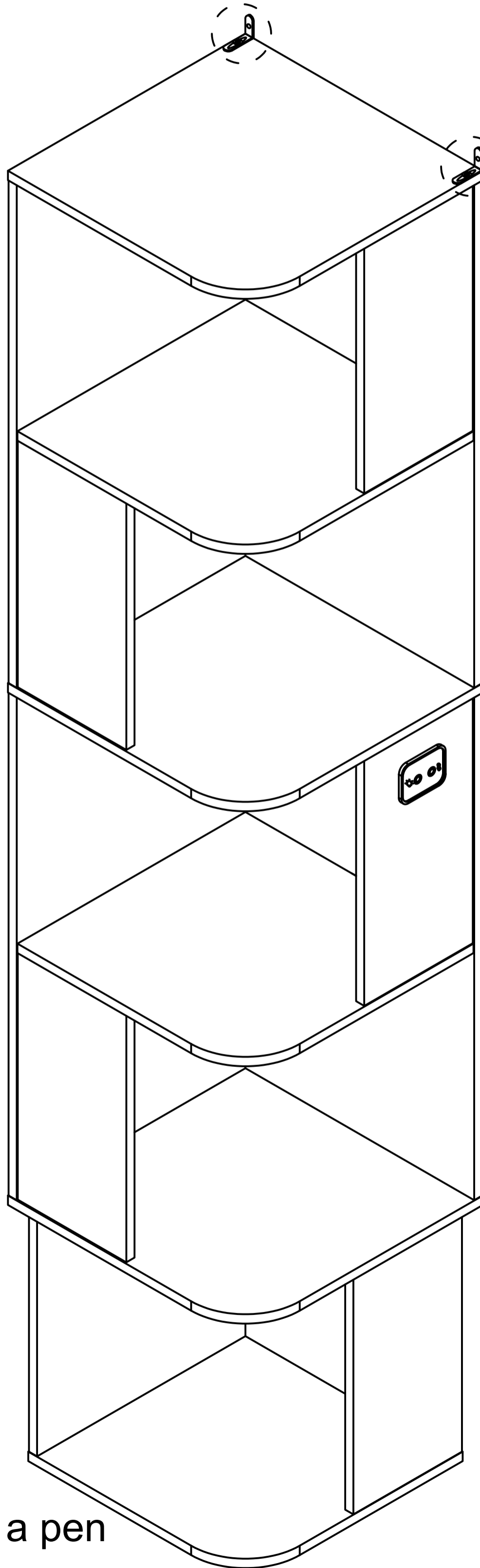

First, install the anti fall hardware onto the cabinet as shown in the picture.



Next, mark the wall with a pen through the holes in the anti-fall hardware.

Step 40

- (H)  x2
-  x2  x2

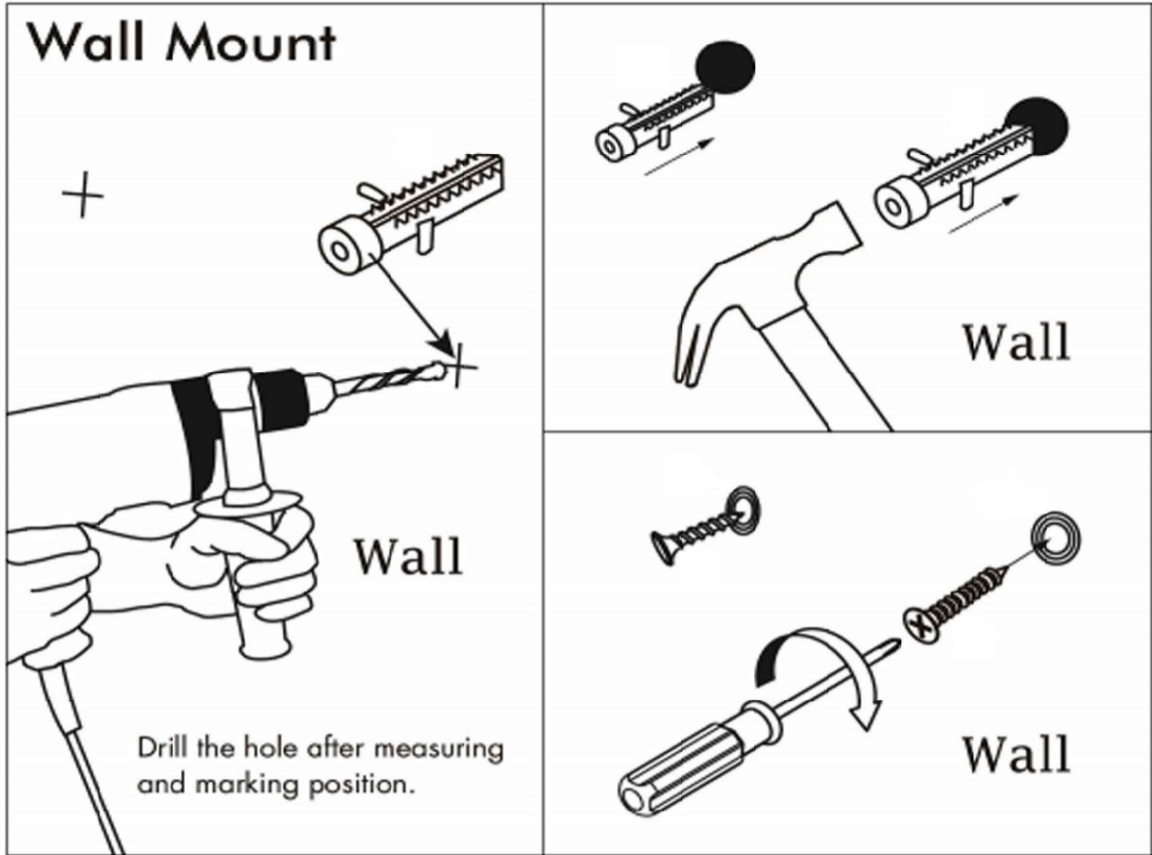

Use an electric drill to drill the hole, then insert the colloidal particles.

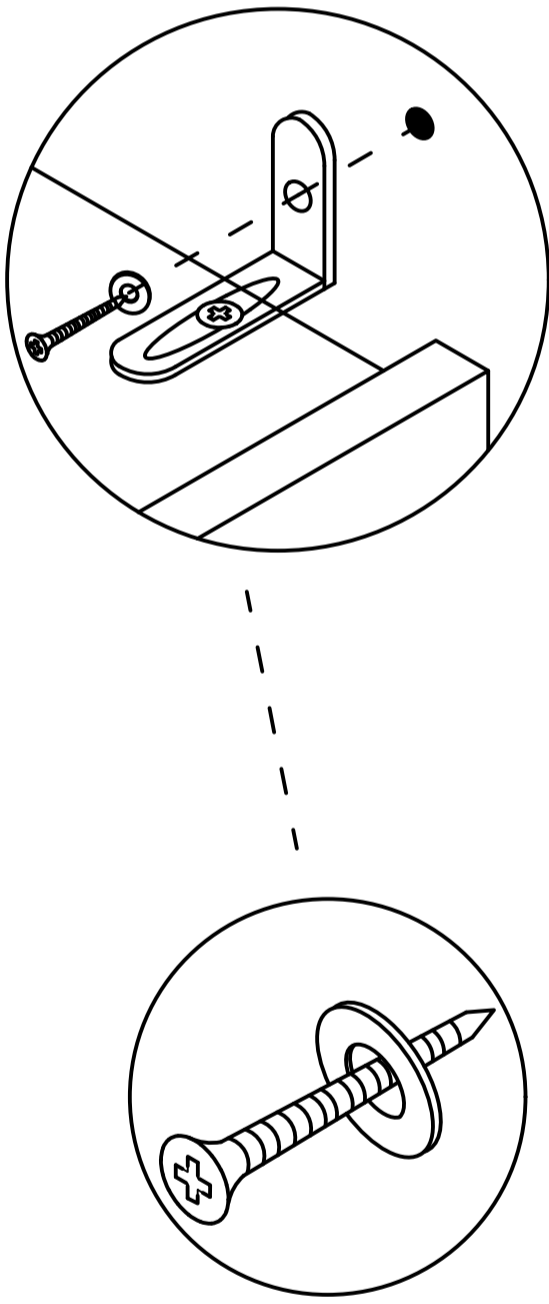
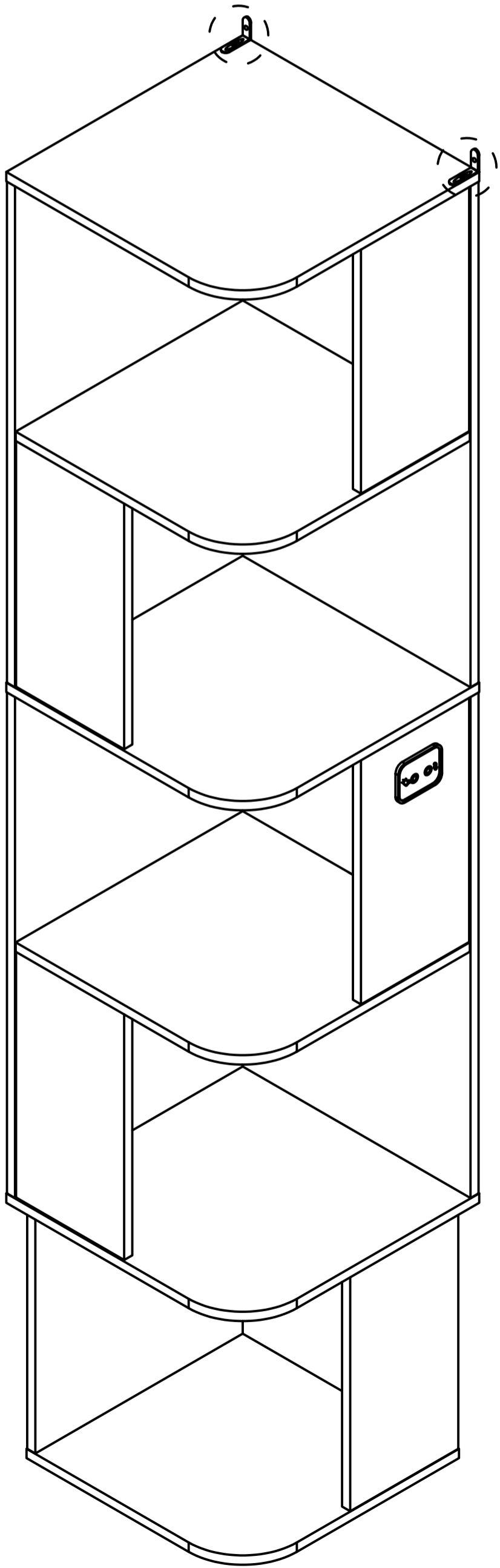

4x45mm

Secure the dressing table to the wall.

Step 41

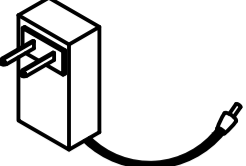
F  x1

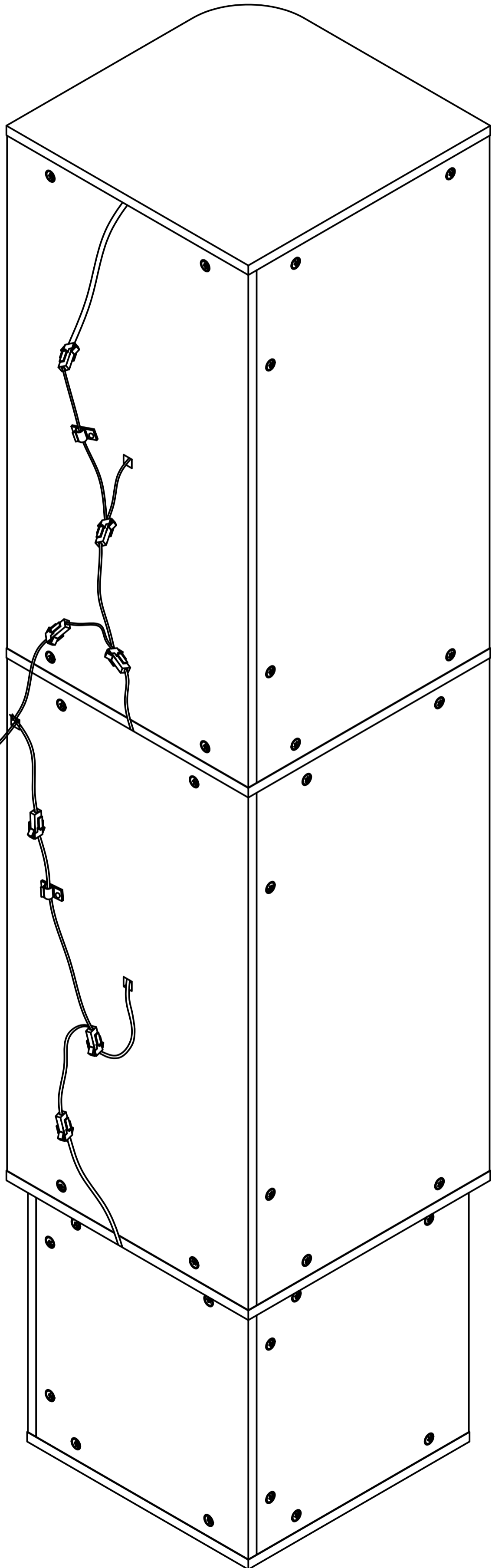
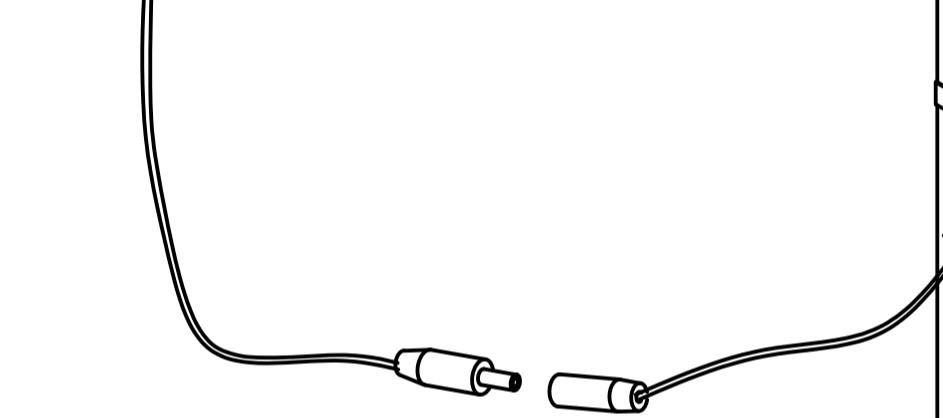
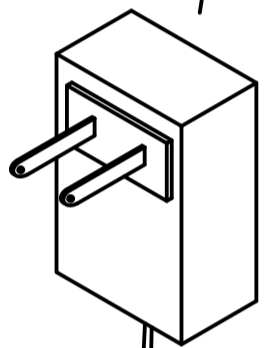
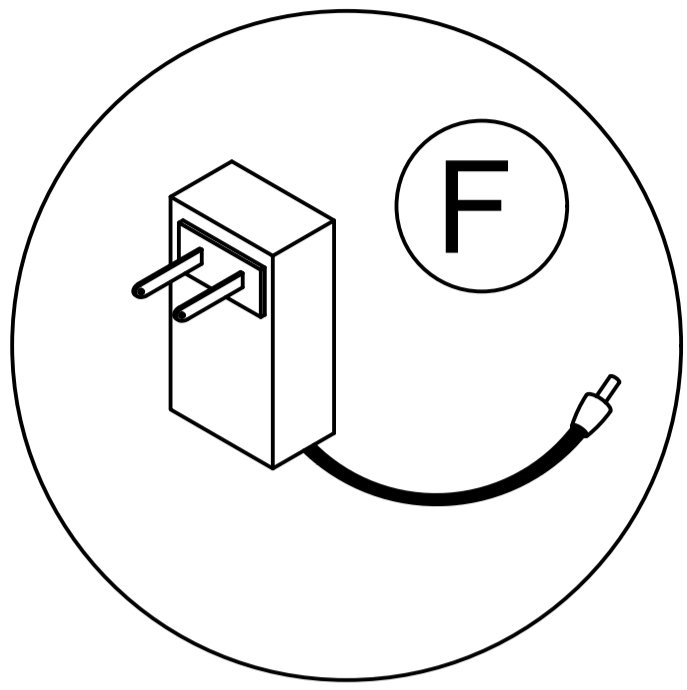

User's Guide

Thank you for purchasing this product. To use this product, please plug it into a 12V Dc power supply. Ensure the product is functioning normally after it is connected to power.

introduction

This box is an intelligent controller with two touch buttons. It can turn the light ON/OFF, change light colors, and adjust the light's luminance.

Product Show

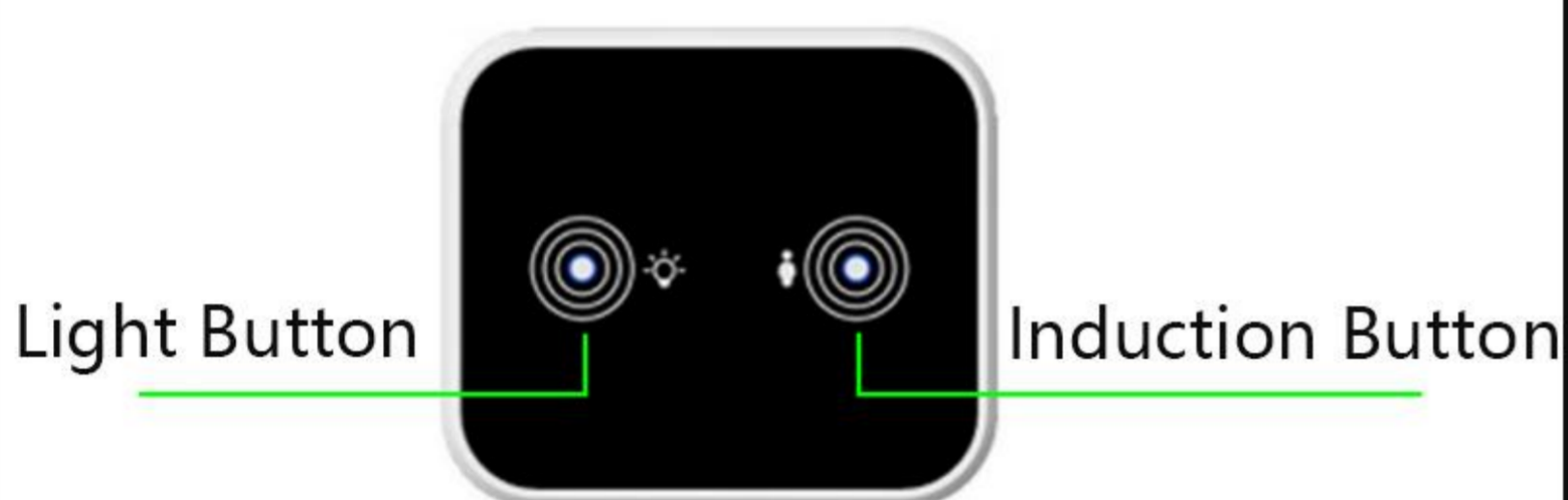

ATTENTION PLEASE

1. If there is no touch response suddenly. Re-plug the power to reset the touch static electricity.
2. If bubbles appear on the panel, the protective film. remove

Operation



This touch button is used to turn on/off, change colors, and adjust brightness

- A. Short touch -> lighting on -> short touch -> change light color -> short touch -> change light color -> short touch -> change light color -> short touch -> lighting off.
- B. Long touch -> adjust the luminance



Touch Button Functionality

- A.Short Touch: This activates the induction function. The light will automatically turn on when a person is within 1 meter of the controller. The light will automatically turn off after 30 seconds when the person moves away from the controller.
- B. Long Touch: This deactivates the induction function.
- C. Note: When you touch the light button to change the light modes, the induction function will be automatically turned off. It is recommended to activate the induction function only after selecting your desired light color and adjusting the brightness.