

## UP100 Whirl & Twirl UP101 Whirl & Twirl w/Clicker

Parts List			
DESCRIPTION	UP100	UP101	PART NUMBER
BEARING	1	1	177328
SPINNING BOWL	1	1	313018
BENT PIPE	1	1	313024
<b>HARDWARE COMPLETE</b>	1	0	307931
<b>HARDWARE COMPLETE</b>	0	1	308031
BUNGEE CLICKER	0	1	308467
3/8" x 1 1/4" P.B.H.C.S. w/PATCH	5	4	812051
3/8" x 1 3/4" P.B.H.C.S. w/PATCH	0	1	812054
3/8" LOCKWASHER	5	4	817334
3/8" FLAT WASHER	4	4	817410
3/8" FLAT WASHER (1 1/4" O.D.)	1	4	817424
1/2" ANCHOR ROD	1	1	135038

*Unless Otherwise Specified, All Units of Measure are Each*

*\*Items listed below Hardware Complete line are included with Hardware Complete Number*

**Warning: During Installation, Hardware And Small Parts Are Choking Hazards For Young Children. Store Unused Parts Appropriately Until Assembly Is Completed. Once Assembly Is Completed, Remove Any Unused Parts From The Play Environment And Dispose/Save Them In A Secure Location. Any bolt end protruding more than two full threads beyond the face of the nut causes risk of clothing entanglement.**

**Promptly cut-off flush, file smooth, and treat to prevent corrosion.**

**Note: Peen Tee-Nuts and Flatwashers to match radius of pipe after assembly is complete.**

**Note: Loctite (supplied by others) should be used on any non-patch hardware.**

### SPECIFICATIONS:

Spinning Bowl shall be rotationally molded from an extremely durable double-walled low density polyethylene with (UV) light stabilizers and color molded in. This material complies with STM-D-1248, Type 2, Class A, and Federal specification LP-390C, Type 1, Class M, Grade 2 < Category 3, and has a minimum 3/16" wall thickness. Bent Pipe is 2" L.W. pipe, galvanized steel tubing.

### INSTALLATION INSTRUCTIONS:

1. Dig required hole. See Elevation View for correct size.
2. Determine version to be installed. **Important:** If installing Whirl & Twirl **with** clicking option, fasten the bearing assembly to the post assembly with the 3/8" x 1 3/4" P.B.H.C.S. w/Patch, Bungee Clicker and 3/8" Flat Washer (1 1/4" O.D.). See Detail 229.  
**Important:** Do not over-tighten 3/8" x 1 3/4" P.B.H.C.S. w/Patch.
3. **Important:** If installing Whirl & Twirl **without** clicking option, fasten the bearing assembly to the post assembly with the 3/8" x 1 1/4" P.B.H.C.S. w/ Patch, 3/8" Lock Washer and 3/8" Flat Washer (1 1/4" O.D.) as shown in Detail 230.
4. Attach the Spinning Bowl to the bearing assembly using 3/8" x 1 1/4" P.B.H.C.S. w/ Patch, 3/8" Lock Washer and 3/8" Flat Washer as shown in Detail 229 & 230. If installing seat w/ clicking option, cut Black Cable Tie 2 1/2" from center of the 3/8" x 1 3/4" P.B.H.C.S. w/Patch.
5. Insert the anchor rod into the bottom of the post assembly using Detail 231.
6. Tighten all connections. Plumb and level the assembly and pour concrete. **Note:** Temporary bracing may be required until concrete cures. ALLOW THE CONCRETE TO SET AT LESS 72 HOURS BEFORE USE.

Issued/Revised: 11/13/14

## UP100 Whirl & Twirl UP101 Whirl & Twirl w/Clicker

7. When the assembly is finished and satisfactory, install Drive Rivets in all clamps to ensure clamps cannot slide down posts. Also eliminate sharp points and sharp edges (burring) on installed hardware like bolts, nuts, etc. See Clamp sub-assembly sheet. **It is very important that all Drive Rivets be installed before allowing use of the equipment, as clamps are not designed to support substantial weight without them.** Install resilient surfacing material within the use zone of play structure in accordance with ASTM specifications F1292 appropriate for the fall height of each structure. Refer to the *Safety Guidelines*.

### **MAINTENANCE PROCEDURE:**

Periodically check hardware for tightness, and tighten as necessary. Always check all parts for breakage or wear, and immediately put equipment out of service until any faulty parts found are repaired or replaced. Also Check all metal parts for rust, paint loss and touch-up if necessary with paint. Check for welded areas and verify integrity. Check periodically resilient surfacing for appropriate depth and remove extraneous materials that could cause injury, infection, or disease. Maintain detailed installation, inspection, maintenance, and repair records for each public-use playground equipment.

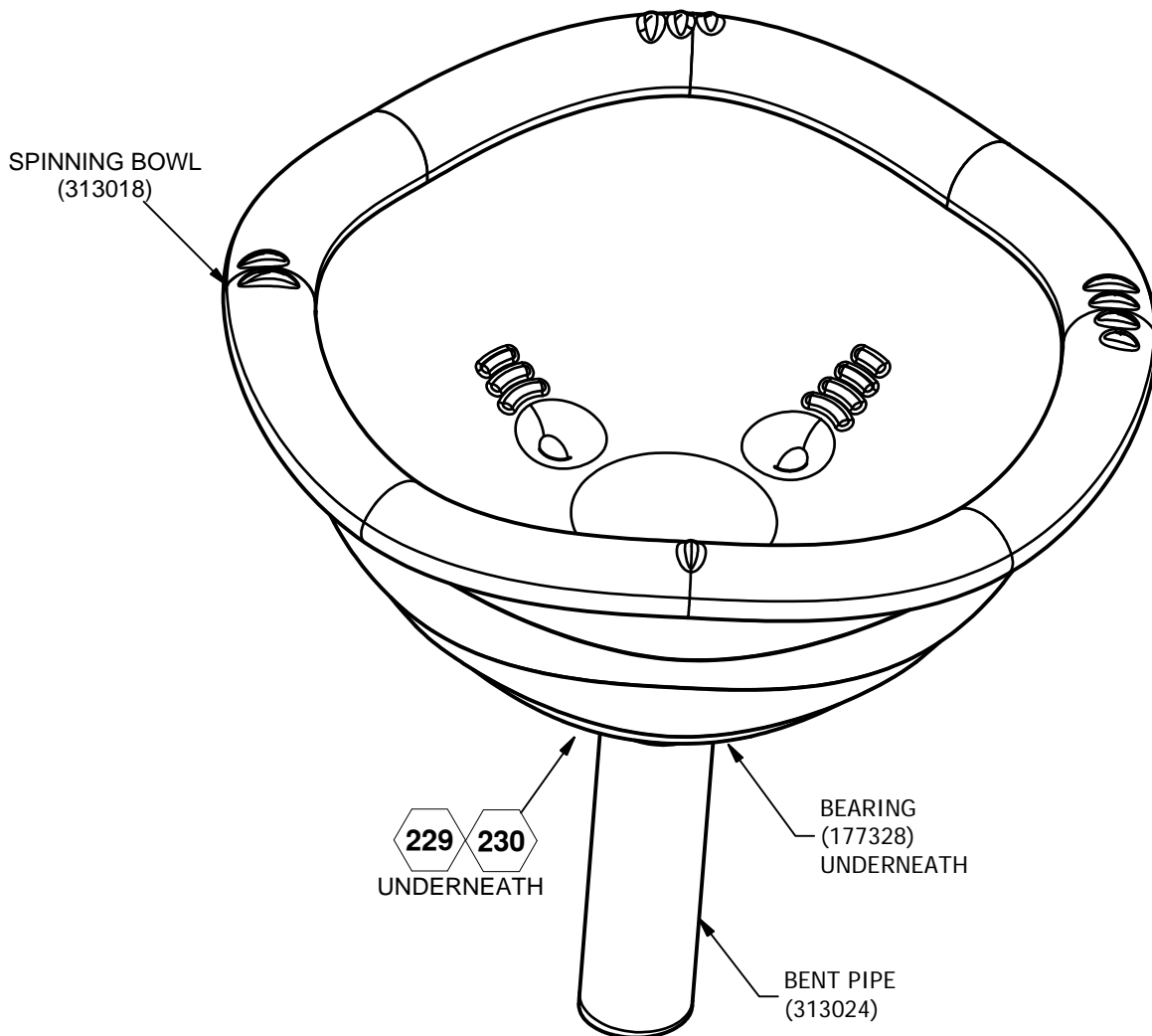

⬡ = INSTALLATION DETAIL

Issued/Revised: 11/13/14

**FINISHED ASSEMBLY  
UP100 SHOWN**

**ultraPLAY**

A PLAYCORE Company

*UP100 Whirl & Twirl*  
*UP101 Whirl & Twirl w/Clicker*

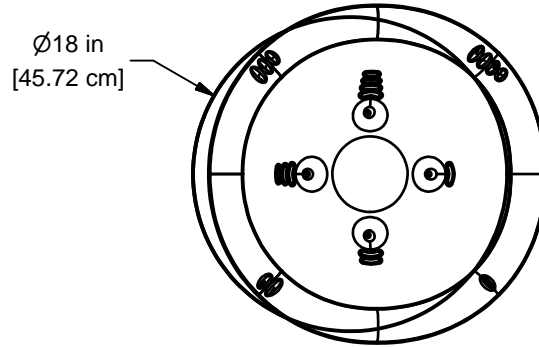

**CONCRETE REQUIRED**  
0.12 CUBIC YARDS  
0.09 [CUBIC METERS]

**PLAN VIEW**

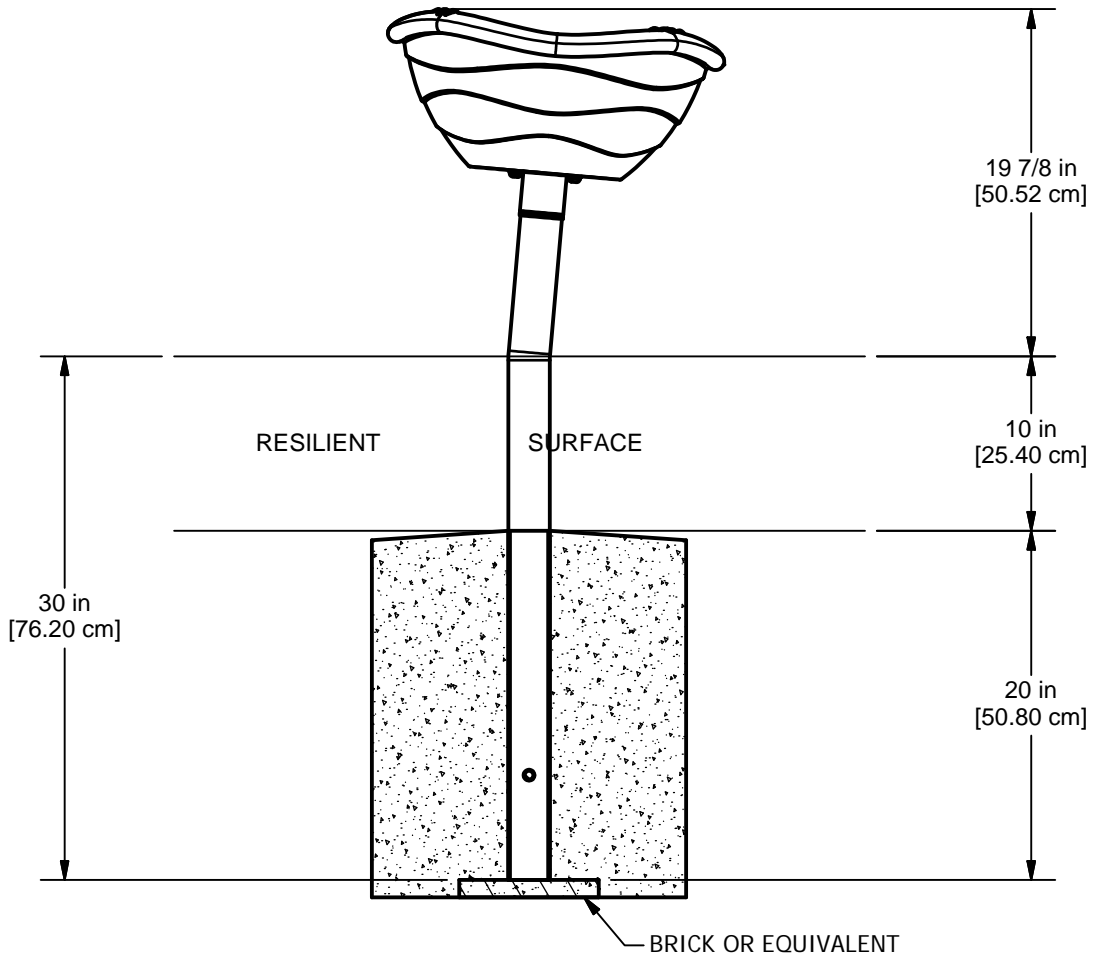

**ELEVATION VIEW**

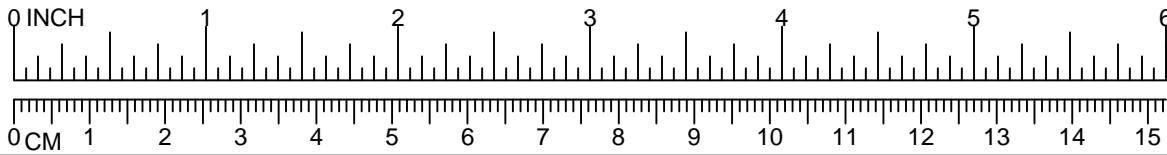

## UP100 Whirl & Twirl UP101 Whirl & Twirl w/Clicker

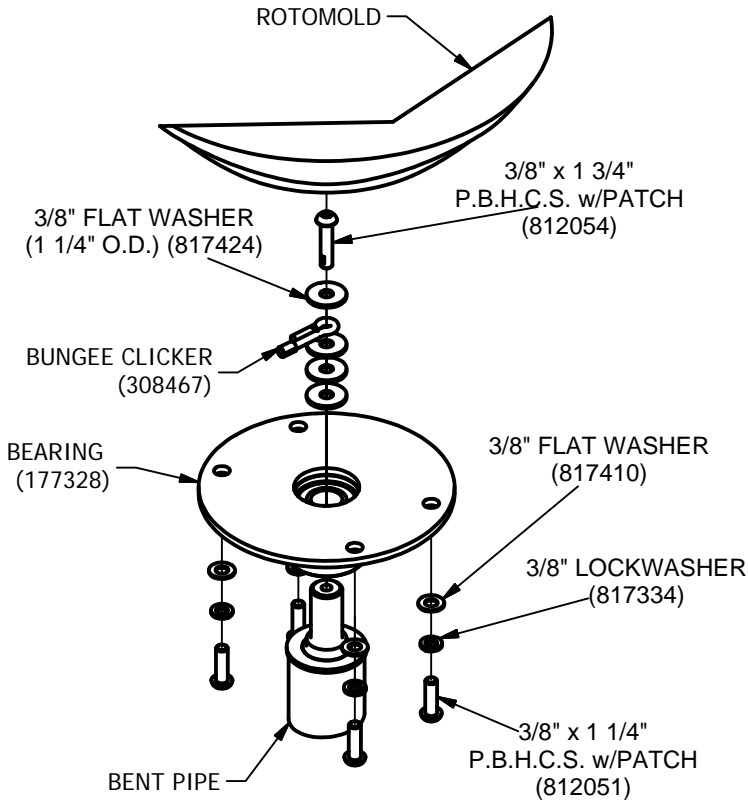

229

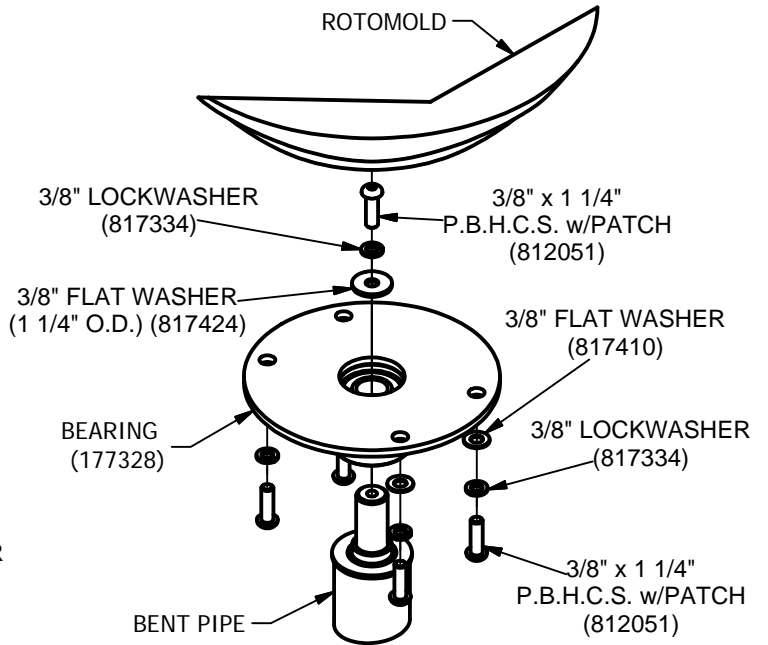

230

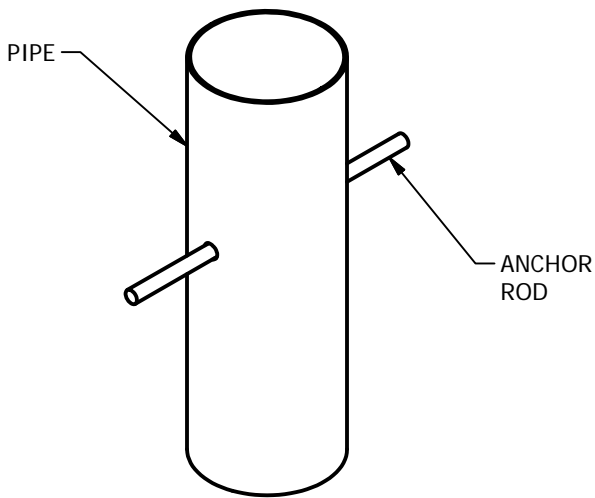

231