

ASSEMBLY INSTRUCTIONS

60W L Desk

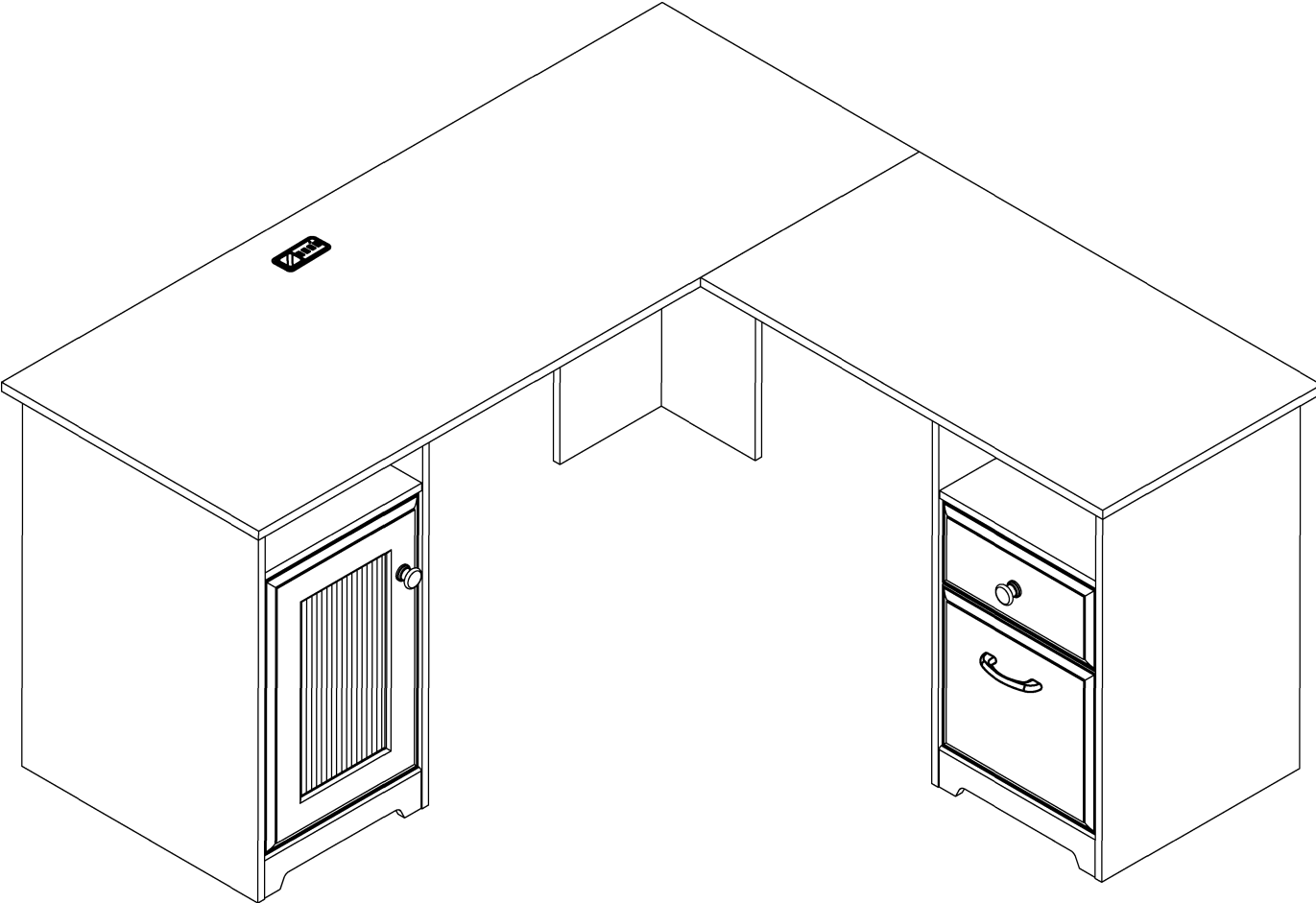

Lot Code#

Thank you for purchasing this Furniture product. We trust that you will be completely satisfied with your product for many years to come. Furniture products are backed by a 1-year warranty and crafted with today's styles in mind for the way you work. **Do not return product to store — contact us first.**

Merci d'avoir acheté ce produit Furniture. Nous sommes sûr que vous serez complètement satisfait de votre meuble pendant de nombreuses années. Les produits Furniture sont garantis pendant 1 ans et sont conçus dans les styles actuels tout en gardant à l'esprit votre façon de travailler. **Ne renvoyez pas le produit au magasin, contactez-nous d'abord.**

Gracias por comprar este producto de Furniture. Confiamos que usted estará completamente satisfecho con su mueble por muchos años. Los productos de Furniture tienen 1 años de garantía y son diseñados con los estilos de hoy en mente para la manera que usted vive. **No devuelva el producto a la tienda, primero comuníquese con nosotros.**

CONTACT US

Monday – Friday
8:30 a.m. – 7:30 p.m. ET
(Except Holidays)

IT'S AS EASY AS 1,2,3

Assembly tips:

1. Read the instructions and become familiar with the parts.
2. Ensure this carton contains all parts, fasteners and hardware.
3. To protect floors, assemble the furniture on the carton.
4. An assistant may be helpful.
5. Use of power tools is not recommended.

Conseils d'assemblage:

1. Lisez les instructions et familiarisez-vous avec les pièces.
2. Assurez-vous que le carton contient toutes les pièces, toutes les pièces de fixation et toute la quincaillerie.
3. Pour protéger vos sols, assemblez le meuble sur le carton.
4. Il peut être utile de vous faire aider.
5. L'utilisation d'outils électriques n'est pas recommandée.

Consejos de Ensamblaje:

1. Lea las instrucciones y familiarícese con las partes.
2. Asegúrese de que esta caja contenga todas las piezas, los sujetadores y el equipo.
3. Para proteger el piso, ensamble el mueble en el carton.
4. Un asistente puede serle útil.
5. El uso de herramientas eléctricas no se recomienda.



CONSUMER
SERVICE

YOU CAN DEPEND ON

Questions? Operators are standing by at our TOLL-FREE help line to assist you with assembly; and, if necessary, to quickly replace damaged/missing parts. Assistance is available 5 days a week. Simply have your store receipt, instruction manual, and part number/description ready when you call our TOLL-FREE help line. It's that easy.

UN SERVICE CLIENTELE SUR LEQUEL VOUS POUVEZ COMPTER

Des questions? Des opérateurs sont prêts sur notre ligne d'assistance GRATUITE pour vous aider à l'assemblage et, si nécessaire, remplacer rapidement les pièces endommagées/manquantes. L'assistance est disponible 5 jours par semaine. Ayez simplement votre reçu de magasin, votre manuel d'instruction et le numéro de pièces/description à votre disposition lorsque vous appelez notre ligne d'assistance GRATUITE. C'est aussi simple que ça.

SERVICIO AL CONSUMIDOR CON EL QUE PUEDE CONTAR

¿Preguntas? Los operadores están listos para ayudarlo con el ensamblaje a través de una línea de ayuda GRATUITA, y en caso de ser necesario, reemplazar de inmediato las piezas dañadas o faltantes. La asistencia está disponible los 5 días de la semana. Solamente tenga listos su recibo de compra, manual de indicaciones y número/descripción de la pieza al momento de llamarnos a la línea de ayuda GRATUITA. Es así de sencillo.

IMPORTANT SAFETY INFORMATION



WARNING

Units must be assembled with the instructions, parts and hardware provided. Improper assembly or use could cause structural failure, instability, tip over, and/or serious injury.

Las unidades deben ser ensambladas de acuerdo a las instrucciones y usando el herraje incluido. El ensamblado incorrecto puede causar un fallo estructural, inestabilidad, o que la unidad se derrumbe, causando posibles heridas personales.

Les unités doivent être assemblées avec les instructions et les matériels donnés. Si vous ne le construisez pas correctement ceci pourrait causer des dommages structuraux, instabilité, se renverser et blesser quelqu'un.



WARNING

This product is designed and intended for use with computer, fax, and printer equipment only. Improper loading with television or other heavy equipment could cause instability, tip over, and/or serious injury.

Este producto está diseñado solamente para el uso con computadores, faxes, e impresoras. Inapropiado uso al poner televisores u otro equipo pesado puede causar inestabilidad, rodamiento, y/o herida (golpes) serios.

Ce produit est uniquement conçu pour une utilisation avec un ordinateur, un télécopieur, ou une imprimante. Un chargement incorrect avec une télévision ou autre matériel lourd peut le rendre instable ou le renverser, et peut vous causer des endommagements sérieux.



WARNING

Do not move unit when loaded. Doing so could cause instability, product collapse, tip over, and/or serious injury.

No mueva la unidad cuando esté cargada. Hacerlo puede causar inestabilidad, que el producto se derrumbe, que se la caiga encima y/o heridas (golpes) serias.

Ne pas déplacer l'unité lorsqu'elle est chargée. Faire ainsi peut causer l'instabilité, l'effondrement ou le renversement du meuble et/ou des endommagements sérieux.



WARNING

Do not load unit without properly attaching back panel. Doing so could cause instability, product collapse, and/or serious injury.

No cargue esta unidad sin el panel de atrás. Hacerlo puede causar inestabilidad, que el producto se derrumbe, y/o heridas (golpes) serias.

Ne pas charger le produit sans attacher correctement le panneau arrière. Faire ainsi peut causer l'instabilité ou l'effondrement du produit et peut vous causer des endommagements sérieux.

IMPORTANT SAFETY INFORMATION

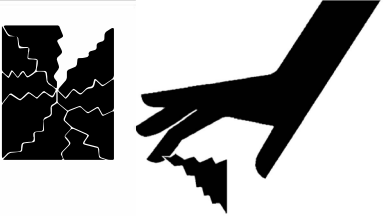
	CAUTION
	
<p>Risk of breaking glass. Handle glass carefully during assembly. Use eye and hand protection. Improper handling can result in cuts or lacerations.</p>	
<p>Riesgo de romper el vidrio. Maneje el vidrio con cuidado al ensamblar esta unidad. Use protección para sus ojos y sus manos. El manejo inapropiado del vidrio puede causarle cortaduras o laceraciones.</p>	
<p>Risque de bris de verre. Faites attention lors de la manipulation du verre pendant l'assemblage. Utilisez des protections pour les yeux et les mains. Une mauvaise manipulation peut provoquer des coupures ou des lacérations.</p>	

	CAUTION
<p>Electronic equipment may overheat causing damage. Do Not store electronic equipment behind doors.</p>	
<p>El equipo electrónico puede sobrecalentarse y causar daños. No almacene equipos electrónicos detrás de las puertas.</p>	
<p>L'équipement électronique peut surchauffer et causer des dommages. Ne stockez pas d'équipement électronique derrière des portes.</p>	

IMPORTANT SAFETY INFORMATION

NOTICE !

This product contains a USB charging HUB with pass through capability. It receives power from a USB port. Use of other power sources such as universal type power adaptors will cause damage to the HUB and any devices plugged into the HUB, and void the warranty.

- DO NOT alter or modify this device.
- DO NOT use power sources other than 127 USB port with a maximum of **2.0 amp** output.
- DO NOT use universal type power adaptors to power this device.

FEATURES:

- 4 ports that support 1.5Mbps, 12Mbps, or 480Mbps data transfer.
- USB 2.0 specifications compatible
- Connects devices having USB ports through cascading multiple hubs

SPECIFICATIONS:

- Voltage output per port: **5V**
- Operational temperature: 5 deg C to 40 deg C (41 deg F to 104 deg F)
- Storage temperature: -20 deg C to 60 deg C (-4 deg F to 140 deg F)
- Humidity: 20% to 80% RH

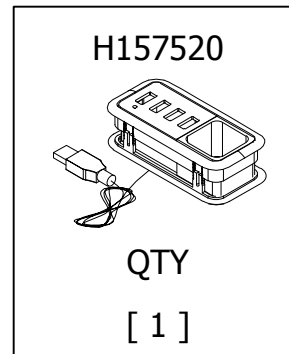

INSTRUCTION STATEMENT: This equipment has been tested and found to comply with the limits for Class B digital devices, pursuant to part 15 of the FCC Rules. These limits are designed to provide reasonable protection against harmful interference in a residential installation. This equipment generates, uses, and can radiate radio frequency energy and if not installed and used in accordance with the instructions, may cause harmful interference to radio communications. However, there is no guarantee that the interference will not occur in a particular installation. If this equipment does cause harmful interference to radio or television reception, which can be determined by turning the equipment off and on, the user is encouraged to try to correct the interference by one or more of the following measures;

- Reorient or relocate the receiver antenna.
- Increase the separation between the equipment and receiver.
- Connect the equipment into an outlet on a circuit different from that of the receiver.
- Consult the dealer or an experienced radio/TV technician for help.

¡ AVISO !

Este producto contiene un HUB (CONCENTRADOR) de carga USB con capacidad de paso de señal. Recibe alimentación desde un puerto USB. El uso de otras fuentes de alimentación, tales como adaptadores de alimentación de tipo universal causará daños al HUB y todos los dispositivos conectados al HUB, y anulará la garantía.

- NO altere ni modifique este dispositivo.
- NO use otras fuentes de alimentación diferentes al Puerto USB 127 con un máximo de **2.0 amperios** de salida.
- NO use adaptadores de alimentación de tipo universal para alimentar este dispositivo.

CARACTERÍSTICAS

- 4 puertos que soportan 1.5 Mbps, 12 Mbps o 480 Mbps de transferencia de datos.
- Compatible con las especificaciones USB 2.0
- Conecta dispositivos con puertos USB en cascada a través de varios hubs

ESPECIFICACIONES

- Tensión de salida por puerto: **5V**
- Temperatura de funcionamiento: 5 °C a 40 °C (41 °F a 104 °F)
- Temperatura de almacenamiento: -20 °C a 60 °C (-4 °F a 140 °F)
- Humedad: 20% a 80% HR

DECLARACIÓN DE INSTRUCCIONES: Luego de probar este equipo, se determinó que cumple con los límites para los dispositivos digitales clase B conforme a la Sección 15 de las reglas de la FCC. Estos límites están diseñados para brindar una protección razonable contra interferencias dañinas en una instalación residencial. Debido a que este equipo produce, emplea y puede emitir energía de radiofrecuencia, si no se instala y utiliza de acuerdo con las instrucciones, puede ocasionar interferencias nocivas a las comunicaciones vía radio. Sin embargo, no hay garantía de que no habrá interferencia en una instalación en particular. Si este equipo causa interferencia perjudicial a la recepción de radio o televisión, lo cual puede ser determinado apagando y encendiendo el equipo, se sugiere al usuario tratar de corregir la interferencia con una o más de las siguientes acciones:

- Reorientar o reubicar la antena receptora.
- Incrementar la separación entre el equipo y el receptor.
- Conectar el equipo en un enchufe eléctrico en un circuito diferente al que está conectado el receptor.
- Consultar con el distribuidor o con un técnico de radio/TV experimentado para solicitar ayuda.

! MISE EN GARDE

Ce produit contient un CONCENTRATEUR de chargement USB avec possibilité de transfert. Il reçoit de l'énergie depuis un port USB. L'utilisation d'autres sources d'alimentation, telles que des adaptateurs d'alimentation de type universel, endommagera le CONCENTRATEUR et tous les périphériques branchés sur celui-ci, et annulera la garantie.

- NE PAS altérer ou modifier ce périphérique.
- NE PAS utiliser de sources d'alimentation autres qu'un port USB de type 127 avec une sortie maximale de **2,0 ampères**.
- NE PAS utiliser d'adaptateurs d'alimentation de type universel pour alimenter ce périphérique.

CARACTÉRISTIQUES

- 4 ports prenant en charge le transfert de données à 1,5 Mbit/s, 12 Mbit/s ou 480 Mbit/s.
- Compatible avec les spécifications USB 2.0
- Permet de connecter des périphériques dotés de ports USB via la mise en cascade de plusieurs concentrateurs.

SPÉCIFICATIONS

- Tension de sortie par port : **5V**
- Température de fonctionnement : de 5 °C à 40 °C (41 °F à 104 °F)
- Température de stockage : de -20 °C à 60 °C (-4 °F à 140 °F)
- Humidité : de 20 % à 80 % RH

INSTRUCTIONS : Cet équipement a été testé et déclaré conforme aux limites des périphériques numériques de classe B, conformément à la partie 15 des règles de la FCC. Ces limites sont conçues pour fournir une protection raisonnable contre les interférences nuisibles dans une installation résidentielle. Cet équipement génère, utilise et peut émettre de l'énergie radiofréquence et, s'il n'est pas installé et utilisé conformément aux instructions, peut causer des interférences nuisibles aux communications radio. Cependant, il n'y a aucune garantie que des interférences ne se produiront pas dans une installation particulière. Si cet équipement provoque des interférences nuisibles à la réception de la radio ou de la télévision, ce qui peut être déterminé en allumant et éteignant l'équipement, l'utilisateur est encouragé à essayer de corriger les interférences en prenant l'une des mesures suivantes :

- Réorienter ou déplacer l'antenne du récepteur.
- Augmenter la séparation entre l'équipement et le récepteur.
- Connecter l'équipement à une prise de courant sur un circuit différent que celui du récepteur.
- Consulter le revendeur ou un technicien en radio / télévision expérimenté pour obtenir de l'aide.

MAXIMUM RECOMMENDED WEIGHT LOADS

MAXIMUM WEIGHT: 200 LBS (90.72 KG)
PESO MÁXIMO: 200 LIBRAS (90.72 KILOGRAMO)
POIDS MAXIMUM: 200 LIVRES (90.72 KILOGRAMME)

MAXIMUM WEIGHT: 15 LBS (6.8 KG)
PESO MÁXIMO: 15 LIBRAS (6.8 KILOGRAMO)
POIDS MAXIMUM: 15 LIVRES (6.8 KILOGRAMME)

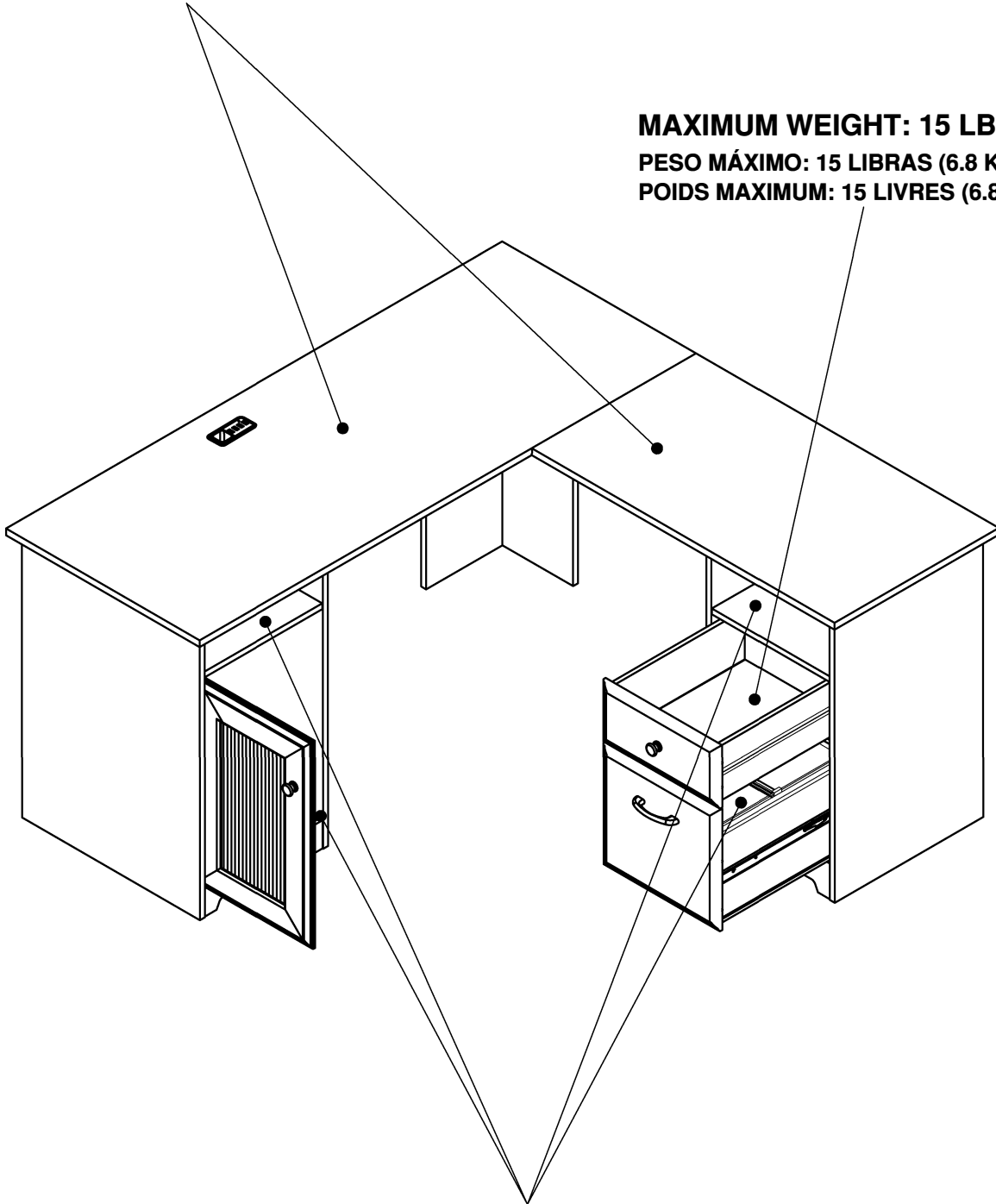

MAXIMUM WEIGHT: 30 LBS (13.6 KG)
PESO MÁXIMO: 30 LIBRAS (13.6 KILOGRAMO)
POIDS MAXIMUM: 30 LIVRES (13.6 KILOGRAMME)

EXPLODED VIEW

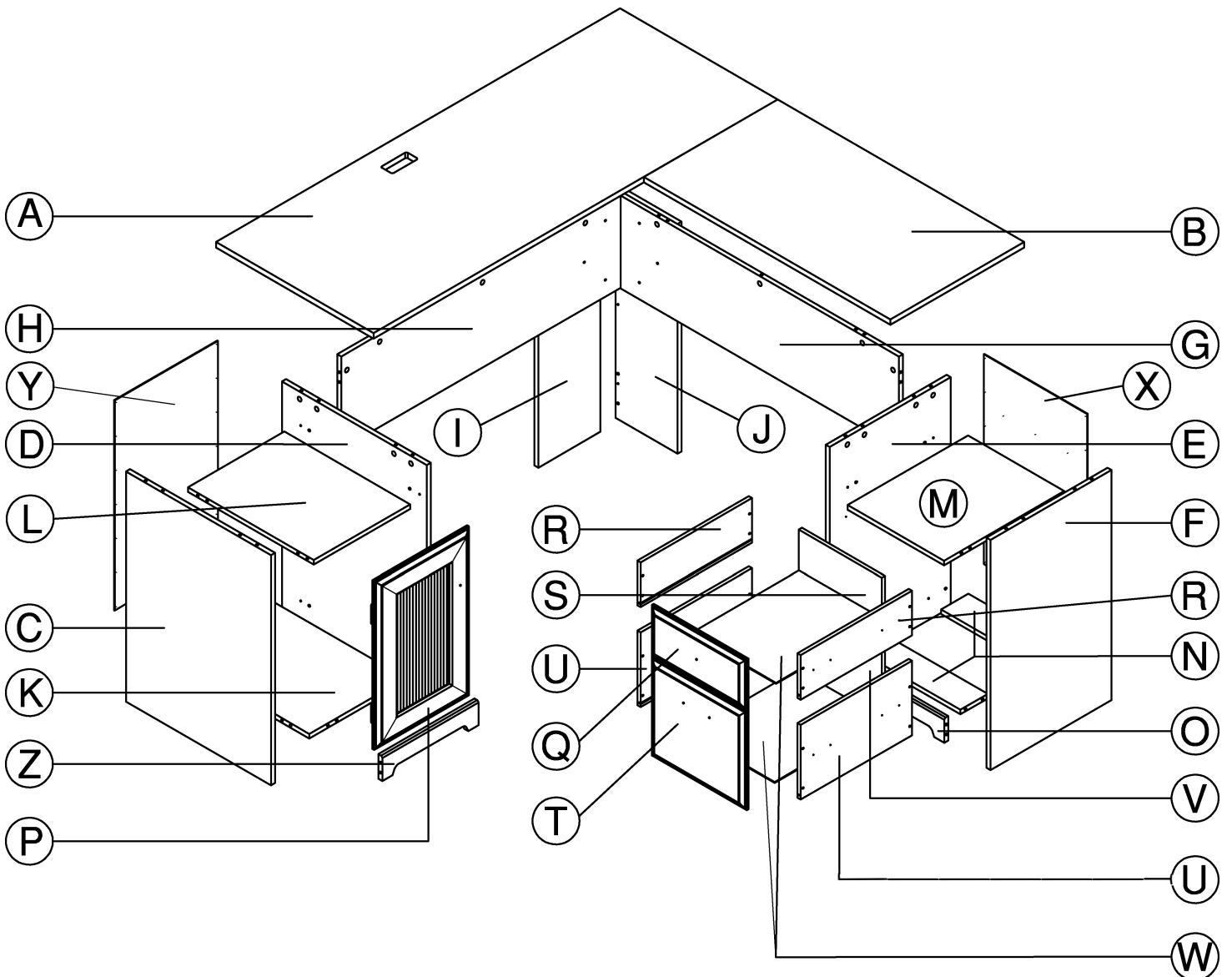
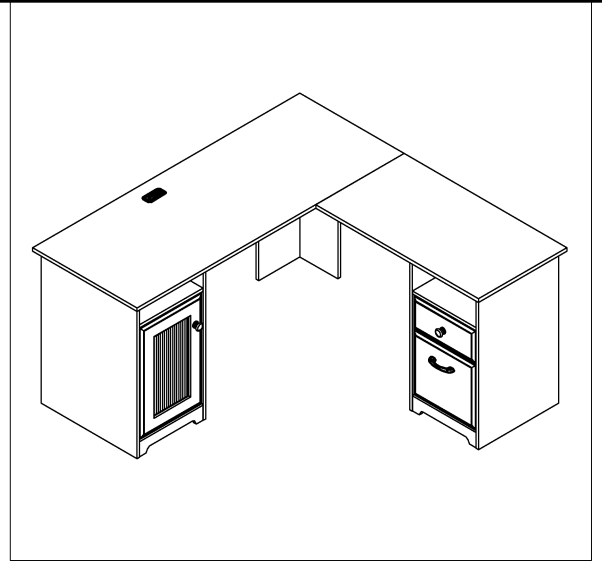

WC31030

A	[1]	W199131	N	[2]	W199144
B	[1]	W199132	O	[1]	W199145
C	[1]	W199133	P	[1]	S199146
D	[1]	W199134	Q	[1]	W199147
E	[1]	W199135	R	[2]	W199148
F	[1]	W199136	S	[1]	W199149
G	[1]	W199137	T	[1]	W199150
H	[1]	W199138	U	[2]	W199151
I	[1]	W199139	V	[1]	W199152
J	[1]	W199140	W	[2]	W199153
K	[1]	W199141	X	[1]	W199154
L	[1]	W199142	Y	[1]	W199155
M	[1]	W199143	Z	[1]	W199156

WC31130

A	[1]	W199157	N	[2]	W199170
B	[1]	W199158	O	[1]	W199171
C	[1]	W199159	P	[1]	S199172
D	[1]	W199160	Q	[1]	W199173
E	[1]	W199161	R	[2]	W199174
F	[1]	W199162	S	[1]	W199175
G	[1]	W199163	T	[1]	W199176
H	[1]	W199164	U	[2]	W199177
I	[1]	W199165	V	[1]	W199178
J	[1]	W199166	W	[2]	W199179
K	[1]	W199167	X	[1]	W199180
L	[1]	W199168	Y	[1]	W199181
M	[1]	W199169	Z	[1]	W199182

WC31330

A	[1]	W199183	N	[2]	W199196
B	[1]	W199184	O	[1]	W199197
C	[1]	W199185	P	[1]	S199198
D	[1]	W199186	Q	[1]	W199199
E	[1]	W199187	R	[2]	W199200
F	[1]	W199188	S	[1]	W199201
G	[1]	W199189	T	[1]	W199202
H	[1]	W199190	U	[2]	W199203
I	[1]	W199191	V	[1]	W199204
J	[1]	W199192	W	[2]	W199205
K	[1]	W199193	X	[1]	W199206
L	[1]	W199194	Y	[1]	W199207
M	[1]	W199195	Z	[1]	W199208

WC31530

A	[1]	W199209	N	[2]	W199222
B	[1]	W199210	O	[1]	W199223
C	[1]	W199211	P	[1]	S199224
D	[1]	W199212	Q	[1]	W199225
E	[1]	W199213	R	[2]	W199226
F	[1]	W199214	S	[1]	W199227
G	[1]	W199215	T	[1]	W199228
H	[1]	W199216	U	[2]	W199229
I	[1]	W199217	V	[1]	W199230
J	[1]	W199218	W	[2]	W199231
K	[1]	W199219	X	[1]	W199232
L	[1]	W199220	Y	[1]	W199233
M	[1]	W199221	Z	[1]	W199234

FASTENERS

Fasteners are shown in actual size.

Los fijadores son demostrados en su tamaño actual.

Les attaches sont montrées dans l'échelle grandeur.

H181468

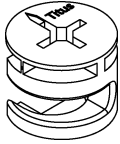

KD Cam

[49]

H180604

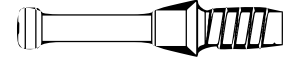

KD Bolt

[49]

H124395



#6 x 1/2"

[12]

H38169

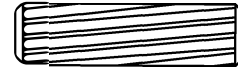

Wood Dowel
8 x 30mm

[33]

H153242

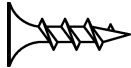

#8 x 5/8"

[8]

H101725



#6 x 1/2"

[22]

H23682



#10 x 1"

[6]

H26053

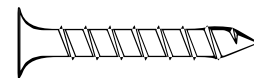

#10 x 1-1/4"

[8]

H158943



M4 x 25mm

[4]

H35251

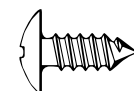

#10 x 1/2"

[16]

HARDWARE

H166306

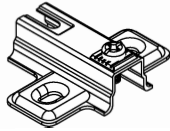

[2]

Mounting Plate

H166299

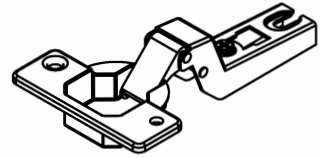

[2]

Hinge

H100446



[2]

Drawer Bracket

H100445

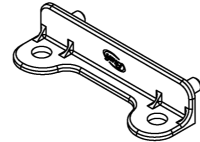

[2]

Drawer Bracket

H158581



[2]

File Extrusion
16-3/8" (416mm)

H39922

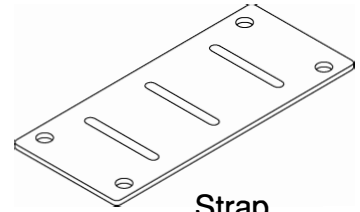

[2]

Strap

Q89897

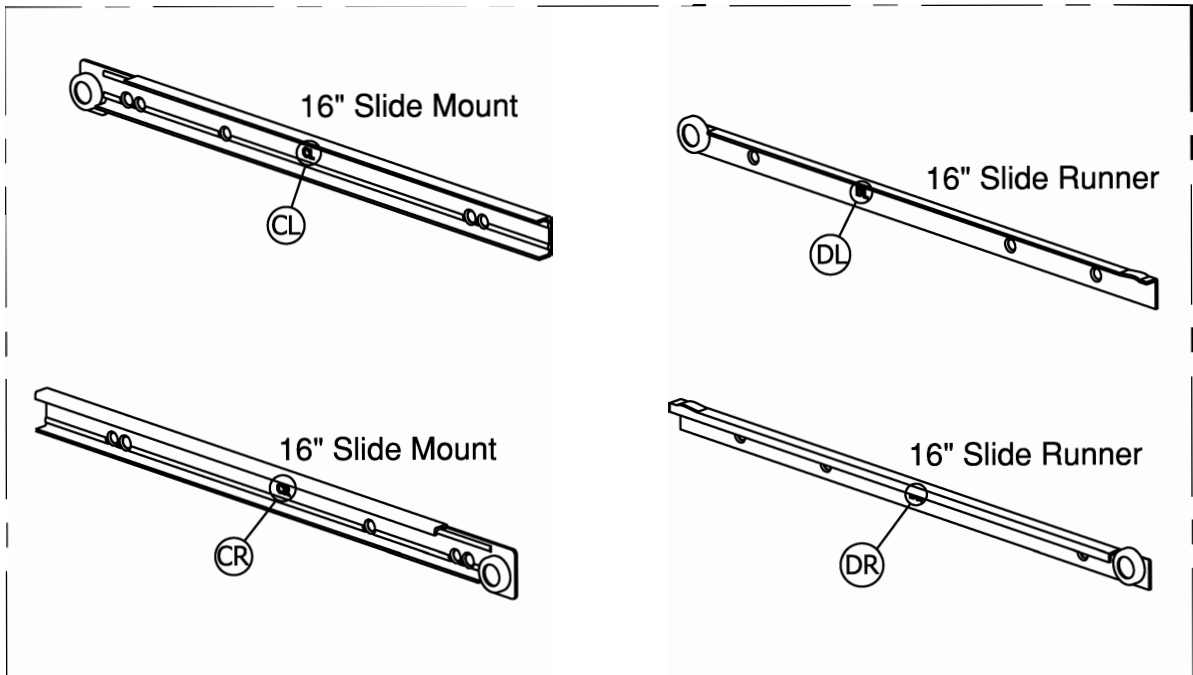

[1]

H167909

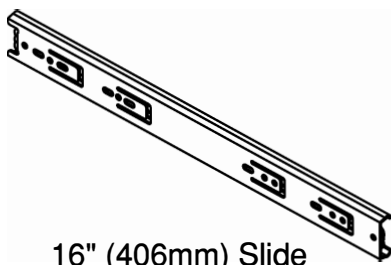

[2]

16" (406mm) Slide

HARDWARE

H89793  [1]
File Bar
12-1/2" (318mm)

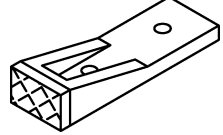
H153233  [1]
Stopper

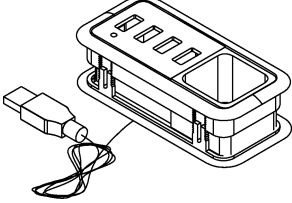
H157520  [1]
USB Port

H153475  [1]
File Extrusion
12" (308mm)

WC31030

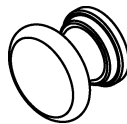
H200220  [2]
Pull

H200221  [1]
Pull

H193336  [29]
Cover Cap

H34174  [40]
#3 x 3/4"

WC31130

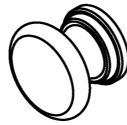
H188981  [2]
Pull

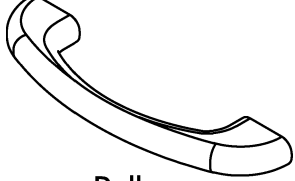
H192372  [1]
Pull

H200203  [29]
Cover Cap

H186726  [40]
#3 x 3/4" (Zinc)

WC31330

H160869

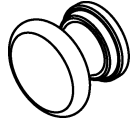

Pull

[2]

H160870

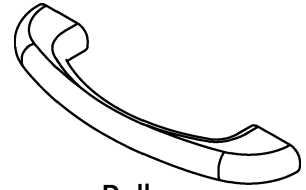

Pull

[1]

H194048

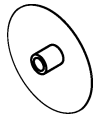

Cover Cap

[29]

H34174



#3 x 3/4"

[40]

WC31530

H200220

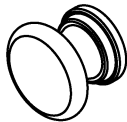

Pull

[2]

H200221

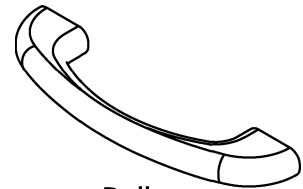

Pull

[1]

H200199



Cover Cap

[29]

H34174



#3 x 3/4"

[40]

STEP 1

H180604

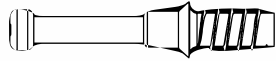

KD Bolt

[5]

H153242



#8 x 5/8"

[4]

H166306

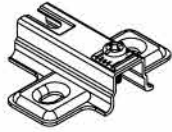

Mounting Plate

[2]

H38169



Wood Dowel
8 x 30mm

[6]

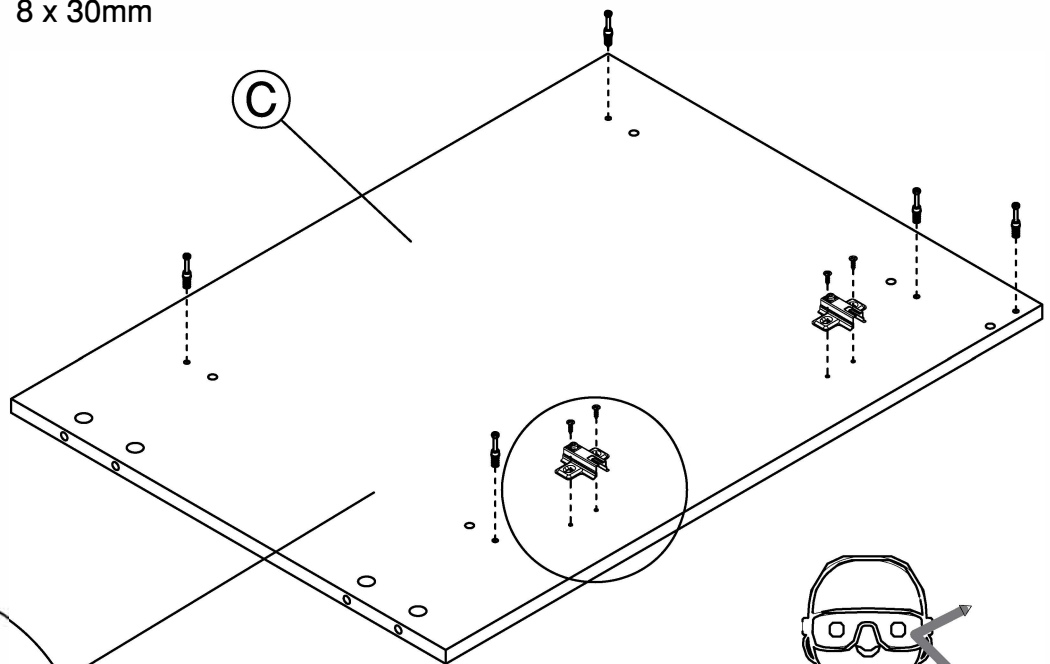

H153242

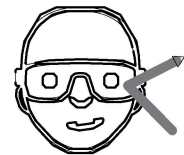
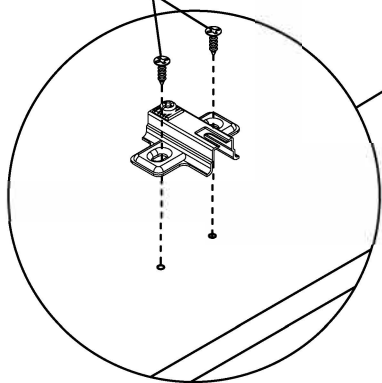

Safety glasses
Gafas de seguridad
Lunettes de protection

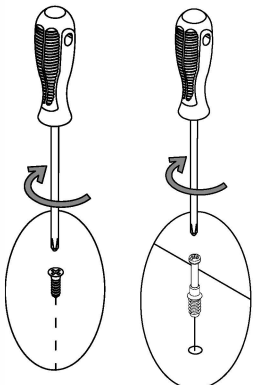
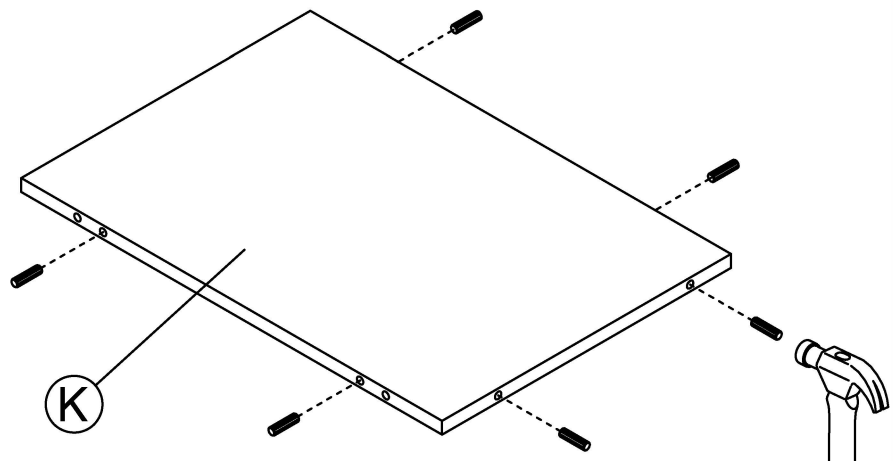

STEP 2

H180604

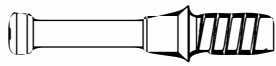

KD Bolt

[7]

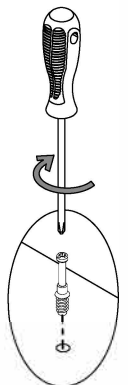
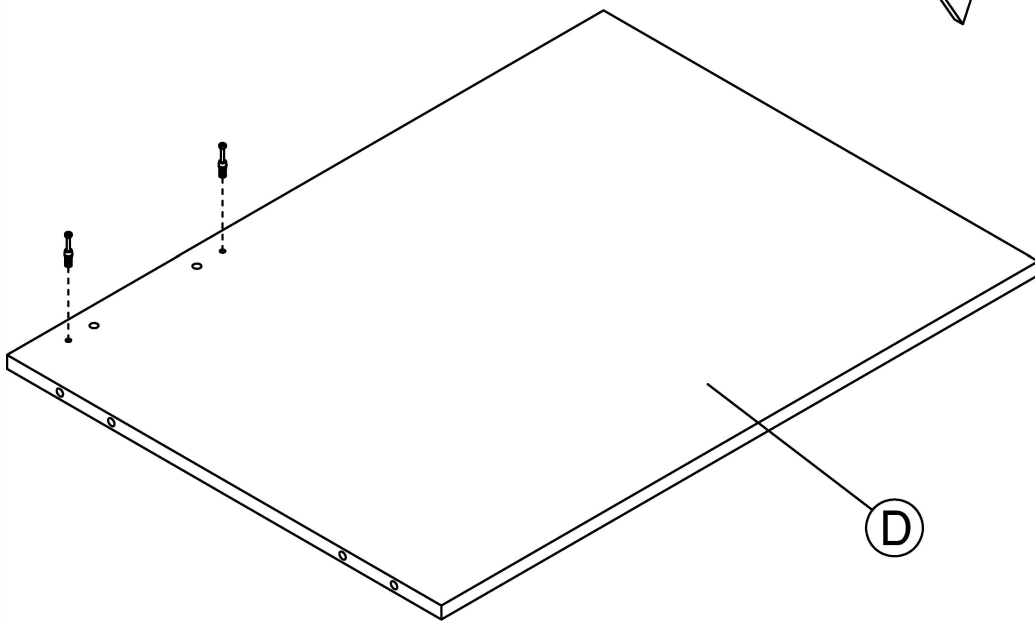
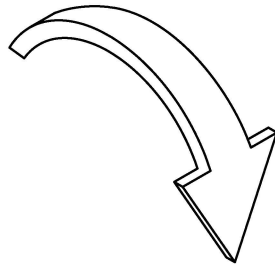
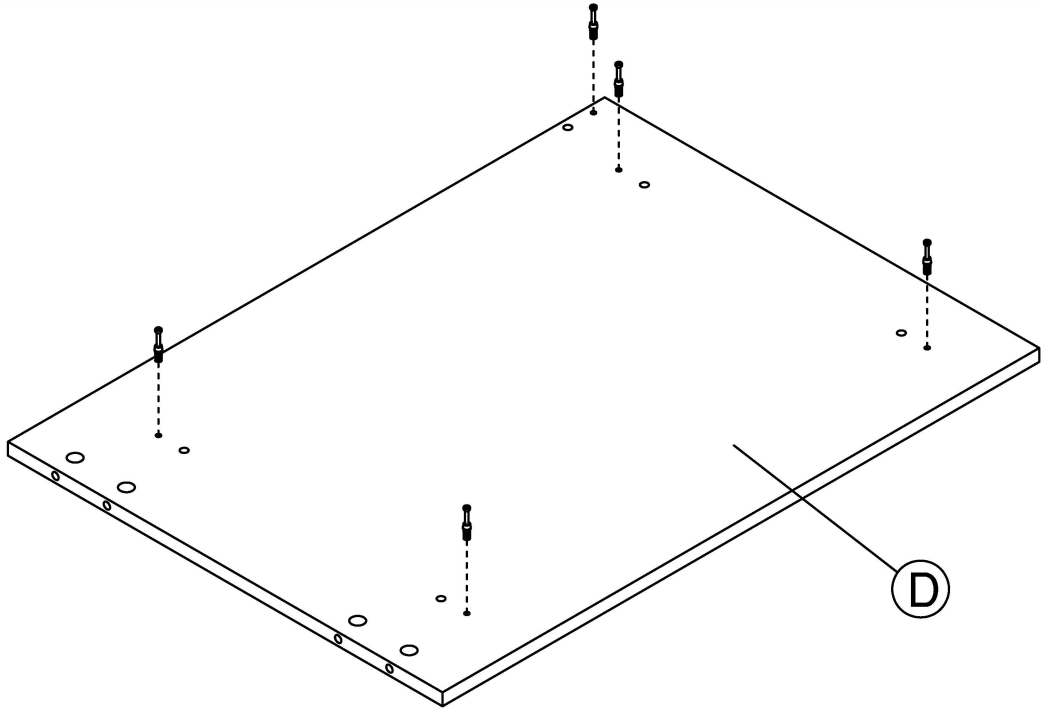

STEP 3

H101725

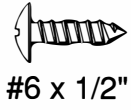

[2]

H38169



Wood Dowel
8 x 30mm

[6]

H153233

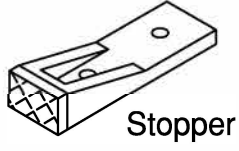

[1]

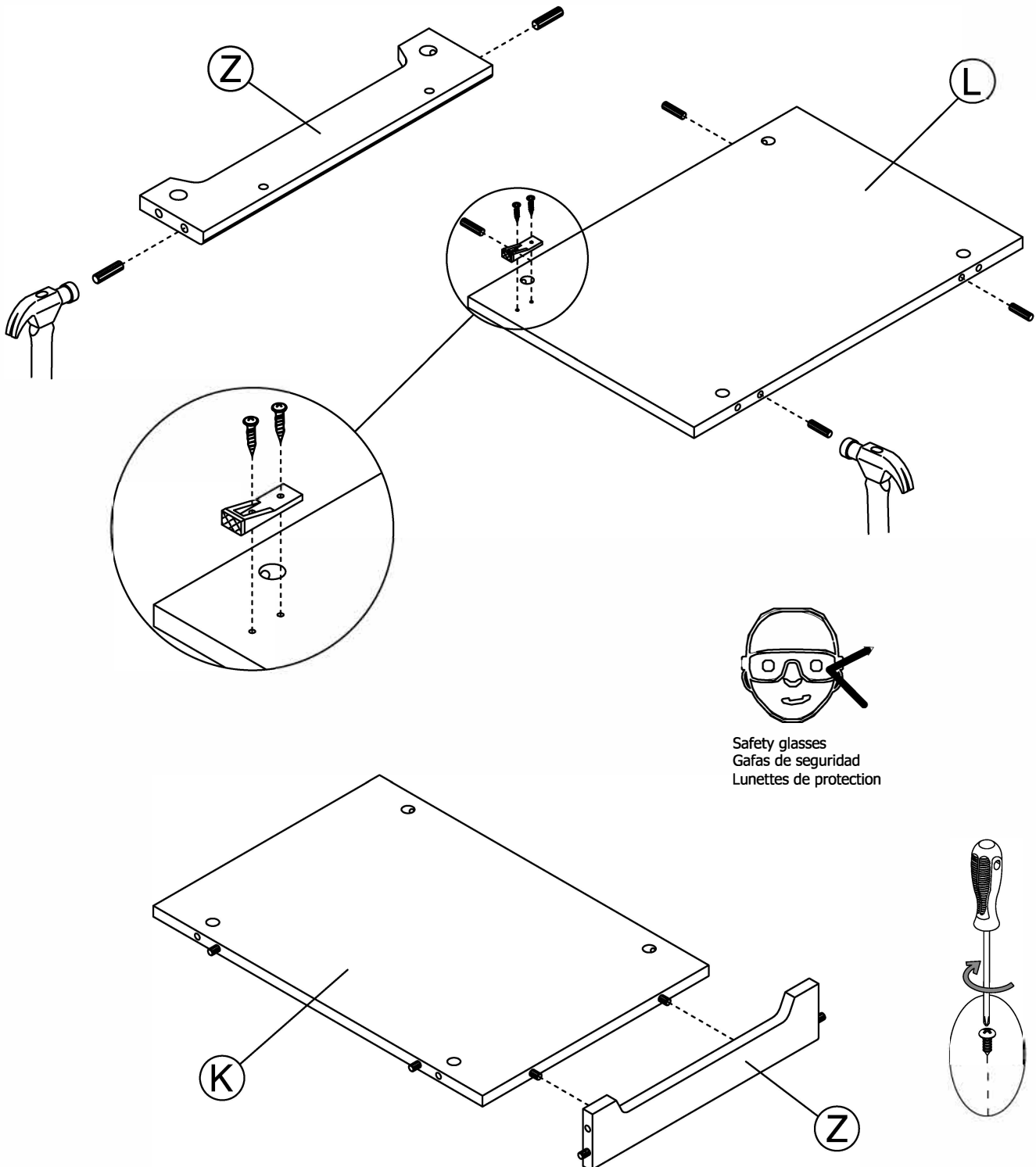

STEP 4

Scan QR Code to Watch Video on:



How to Tighten KD Cams

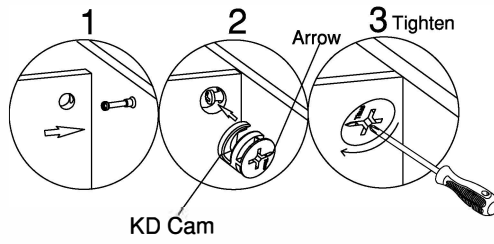

H181468

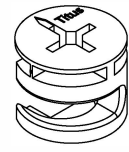

KD Cam

[10]

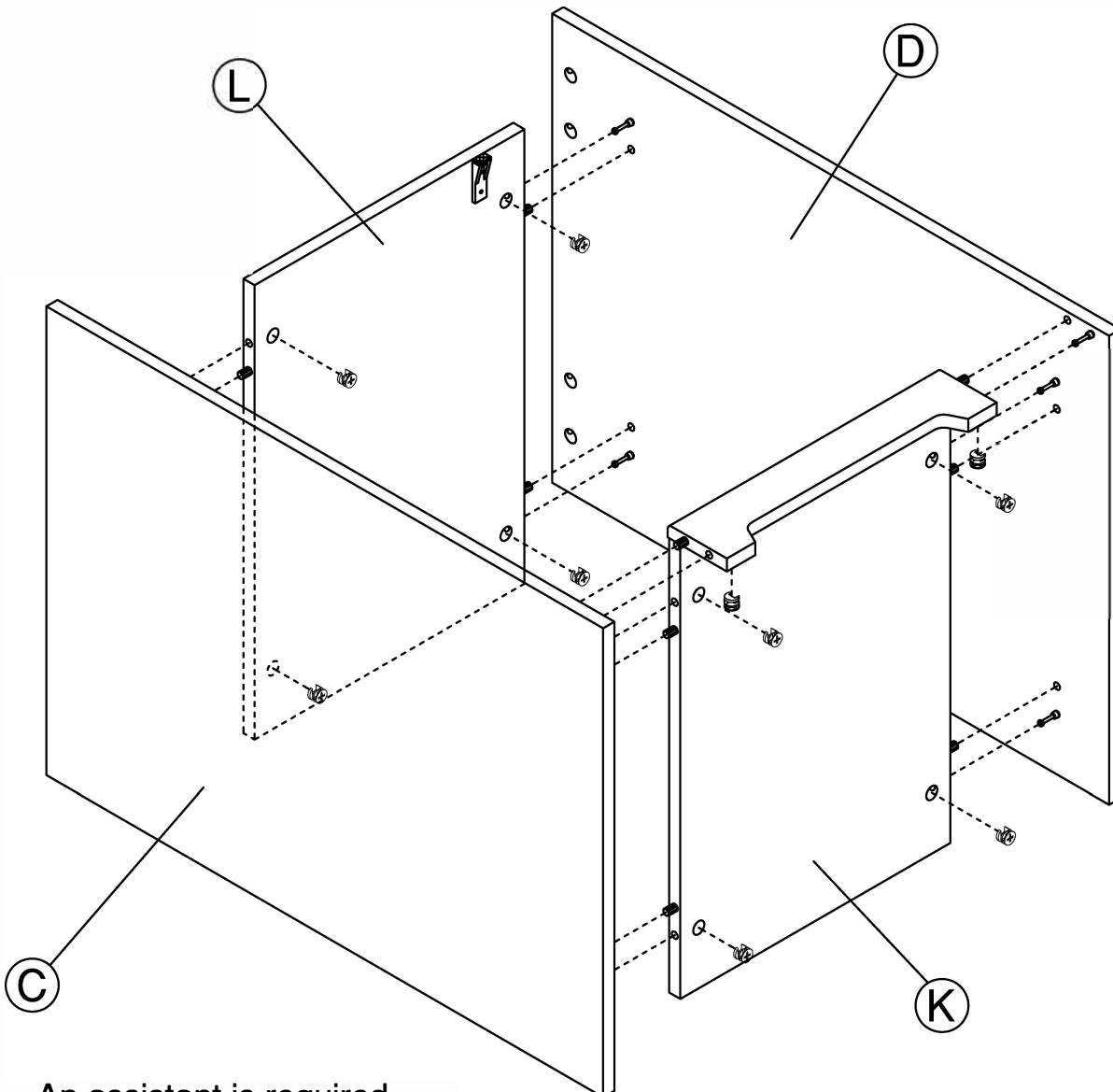

An assistant is required.
Es necesario un ayudante.
Un assistant est nécessaire.

STEP 5

Scan QR Code to
Watch Video on:



How to Separate
and Install Drawer
Slides

Slides Must Be Separated Before Assembly. After Separated, Set Aside Until Needed for Assembly.

Las diapositivas deben separarse antes del montaje.
Después de la separación, déjelo a un lado hasta que sea necesario.

Les glissières doivent être séparées avant l'assemblage.
Après la séparation, mettez de côté jusqu'au moment de l'assemblage.

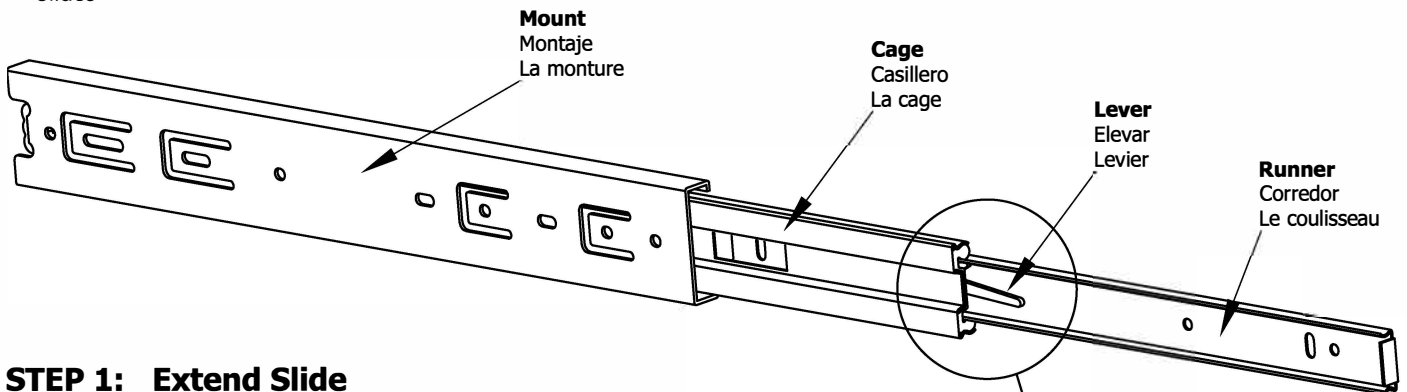

STEP 1: Extend Slide
Extender la diapositiva
Extendre la diapositive

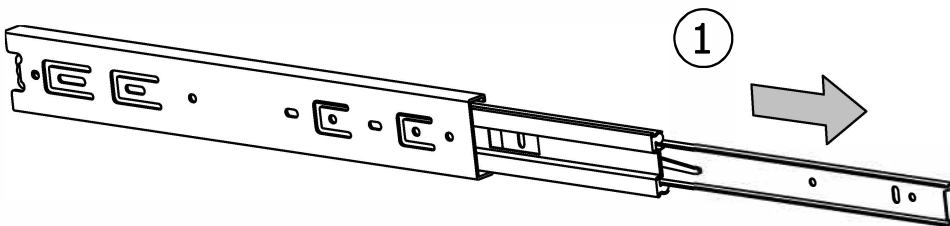

STEP 2: Push Lever UP
Empujar hacia arriba
Lever le levier

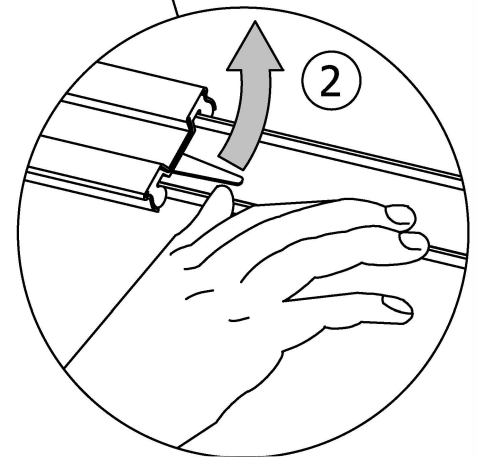

STEP 3: Remove Runner
Quitar el corredor
Enlever le coureur

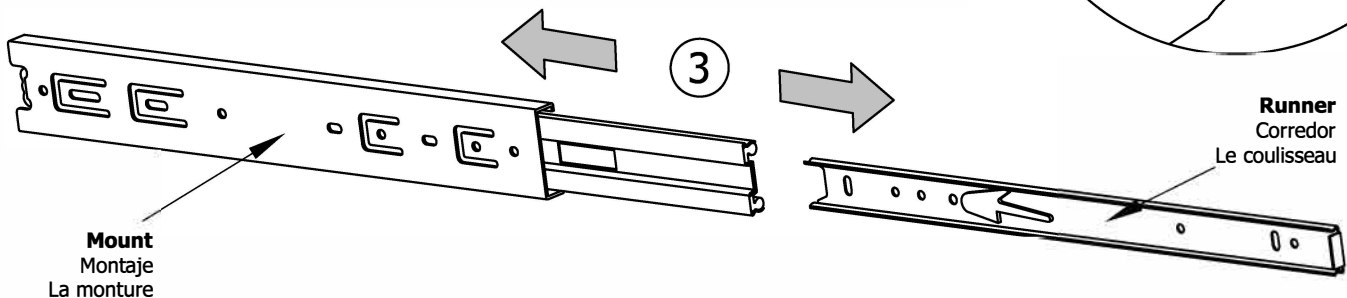

STEP 6

Scan QR Code to Watch Video on:



How to Separate and Install Drawer Slides

H124395  [3]
#6 x 1/2"

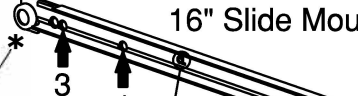
Q89897  16" Slide Mount [1]

H101725  [3]
#6 x 1/2"

Orientation
Orientación
L'orientation

H167909  16" (406mm) Slide Mount [1]

H180604  [7]
KD Bolt

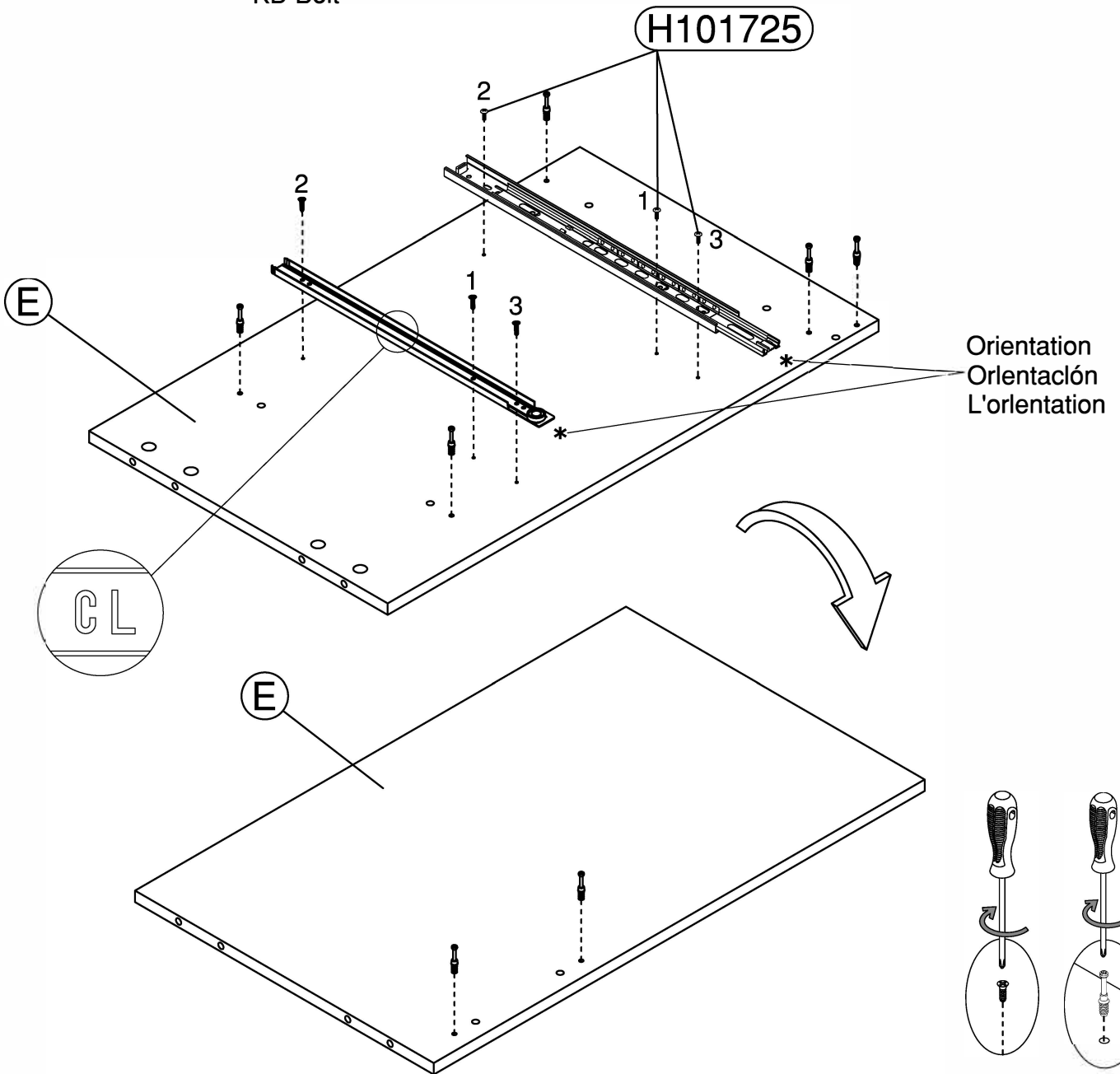



STEP 7

Scan QR Code to Watch Video on:



How to Separate and Install Drawer Slides

H124395  [3]
#6 x 1/2"

H101725  [3]
#6 x 1/2"

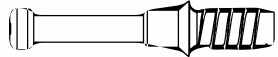
H180604  [5]
KD Bolt

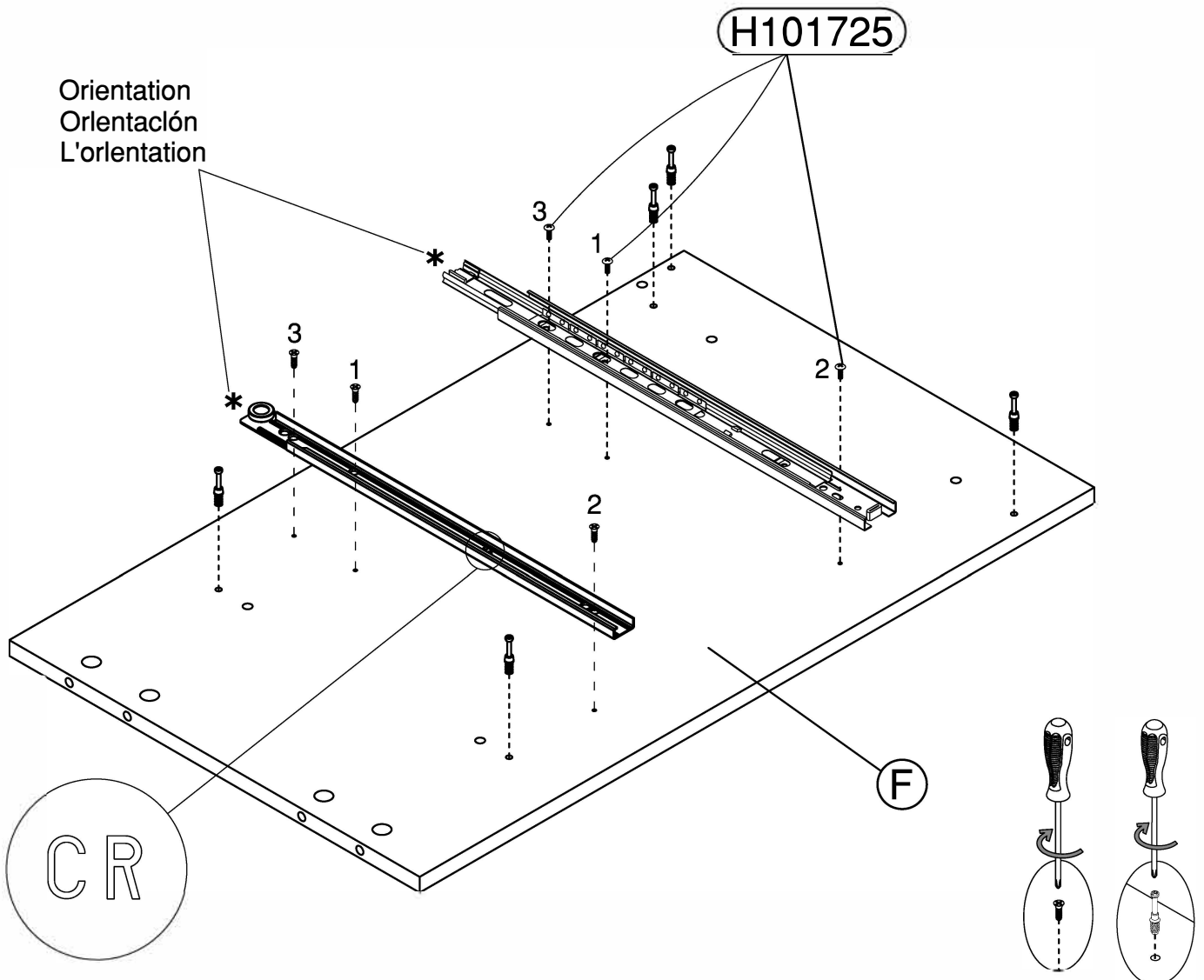
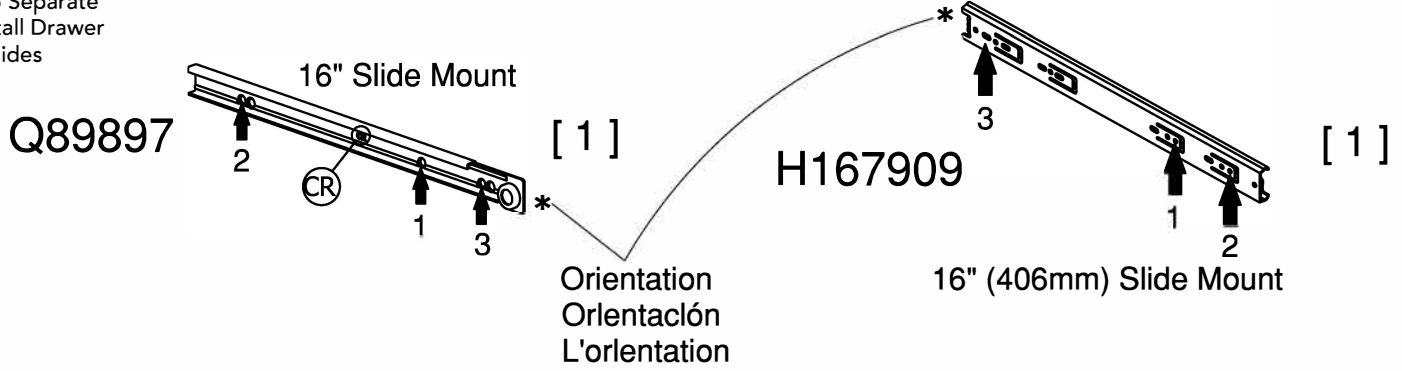

STEP 8

H38169

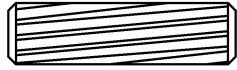

[10]

Wood Dowel
8 x 30mm

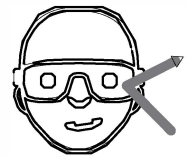
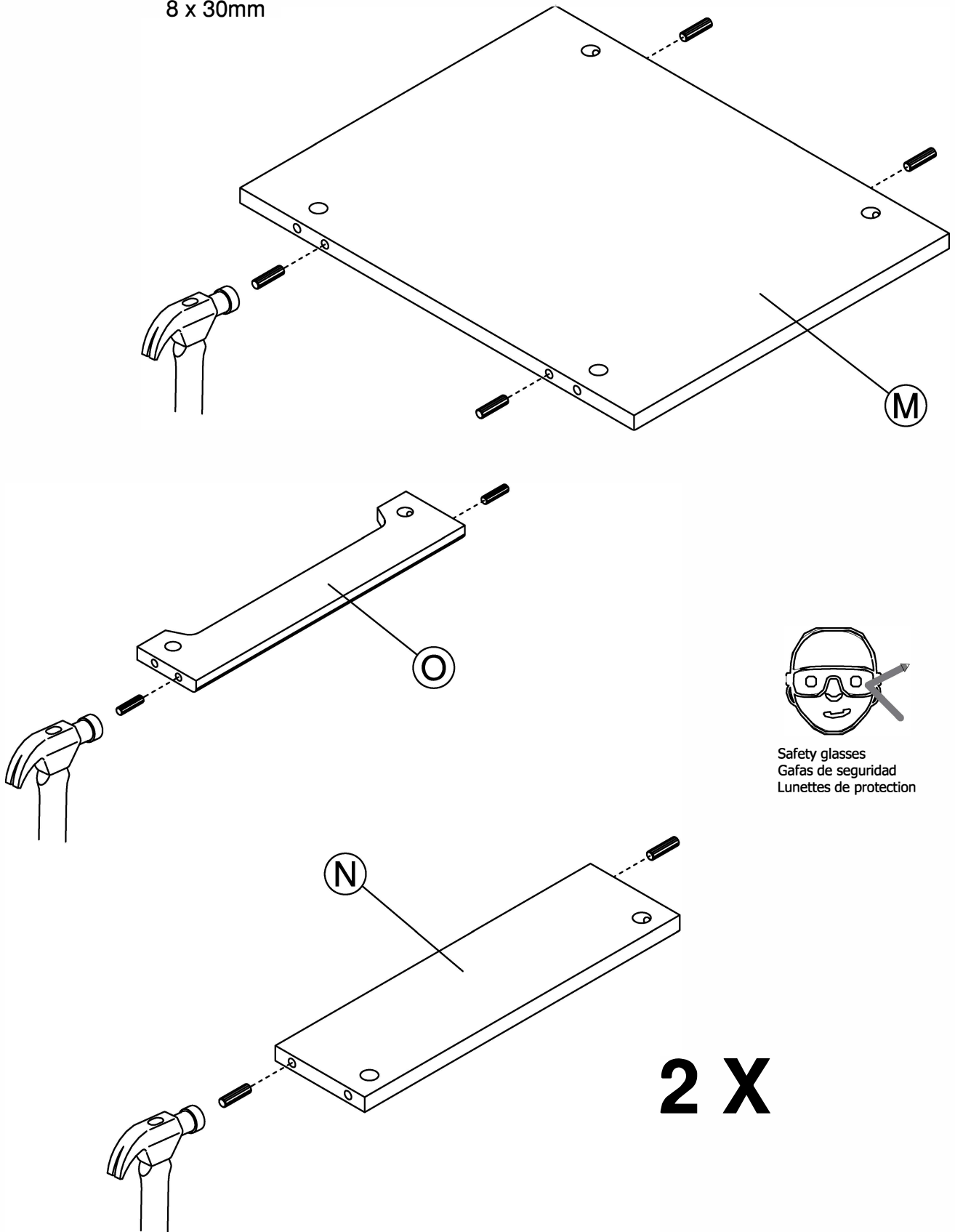

Safety glasses
Gafas de seguridad
Lunettes de protection

2 X

STEP 9

Scan QR Code to Watch Video on:



How to Tighten KD Cams

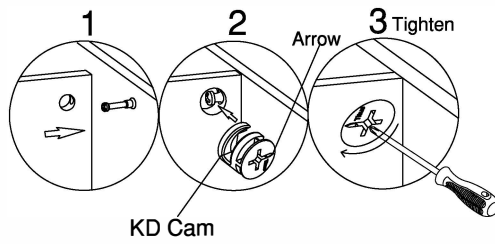

H181468

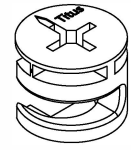

KD Cam

[5]

Finished edge
Borde terminado
Cote fini

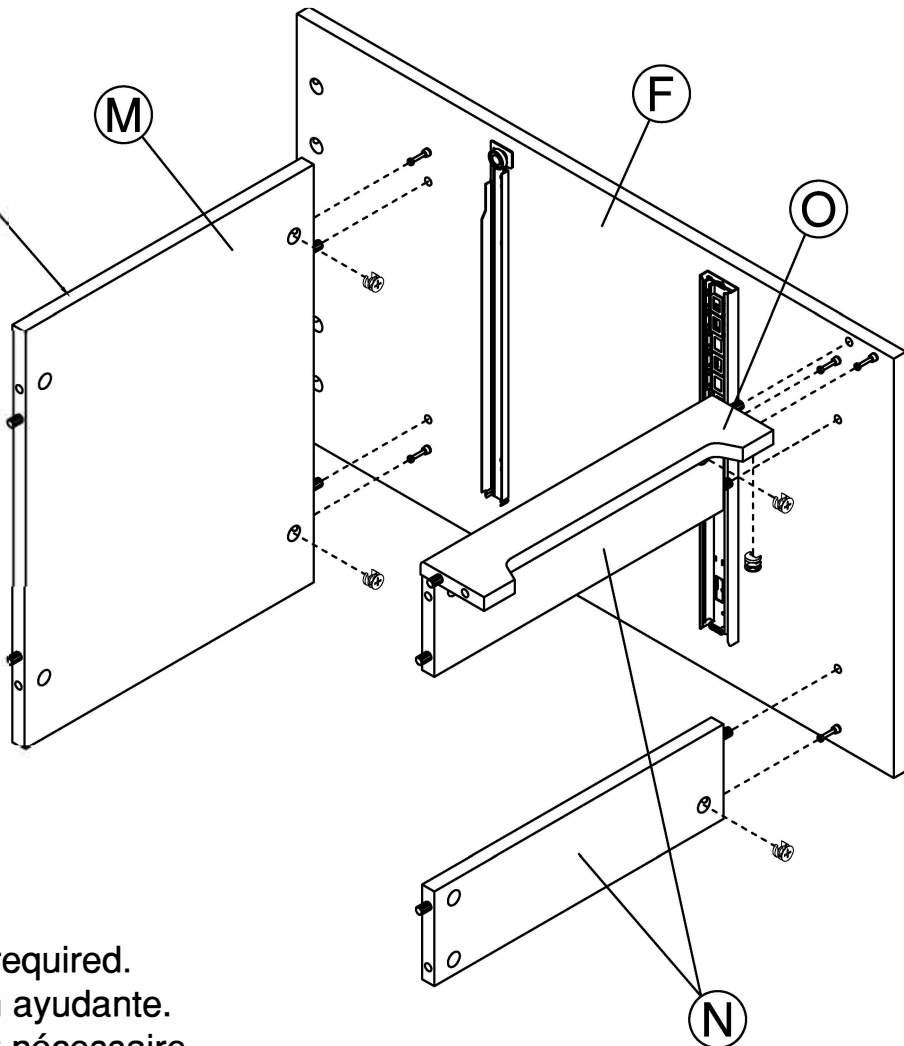

An assistant is required.
Es necesario un ayudante.
Un assistant est nécessaire.

STEP 10

Scan QR Code to Watch Video on:



How to Tighten KD Cams

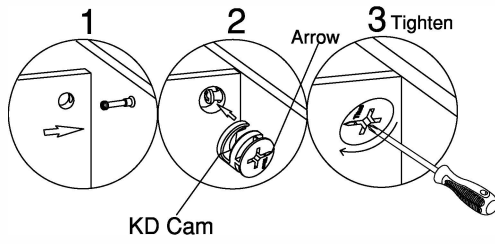

H181468

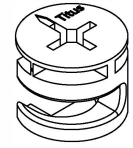

KD Cam

[5]

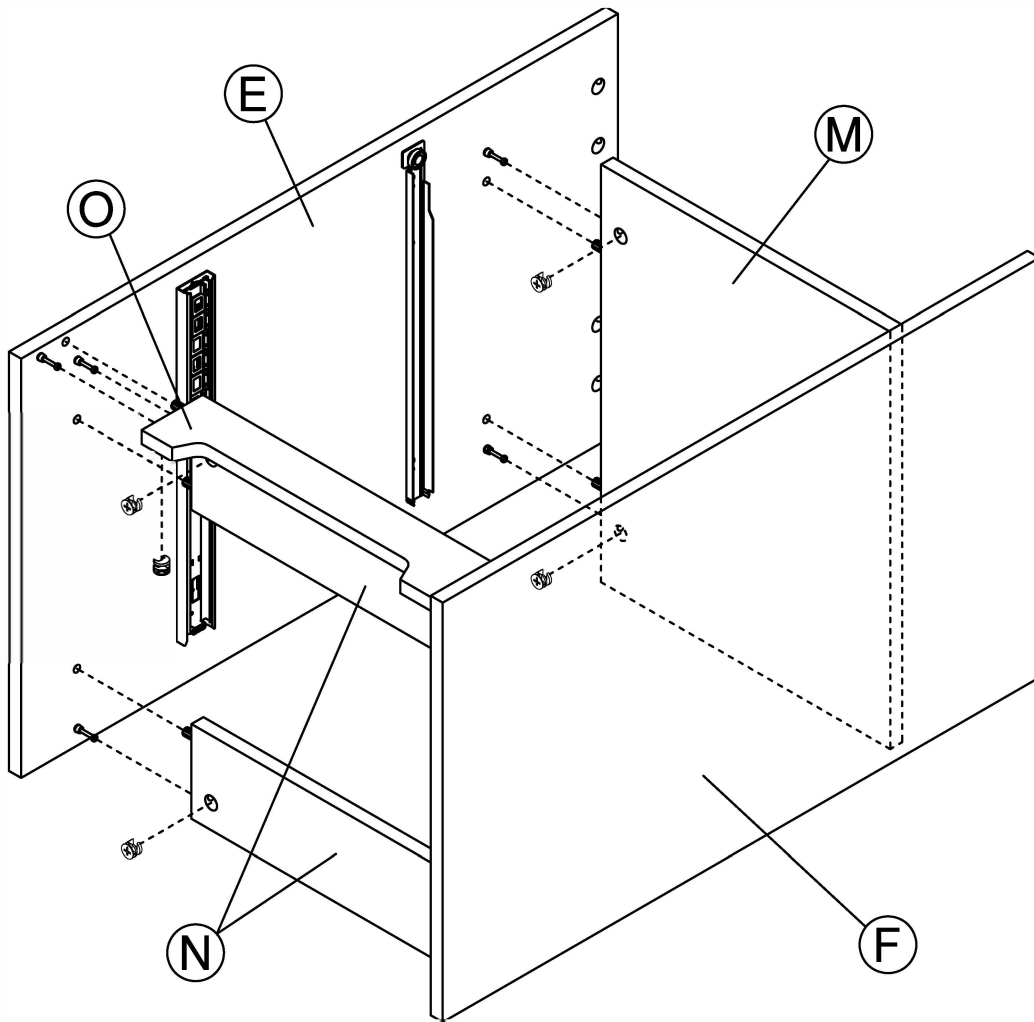

An assistant is required.
Es necesario un ayudante.
Un assistant est nécessaire.

STEP 11

H180604



[3]

KD Bolt

H38169

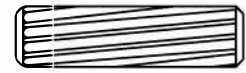

[3]

Wood Dowel
8 x 30mm

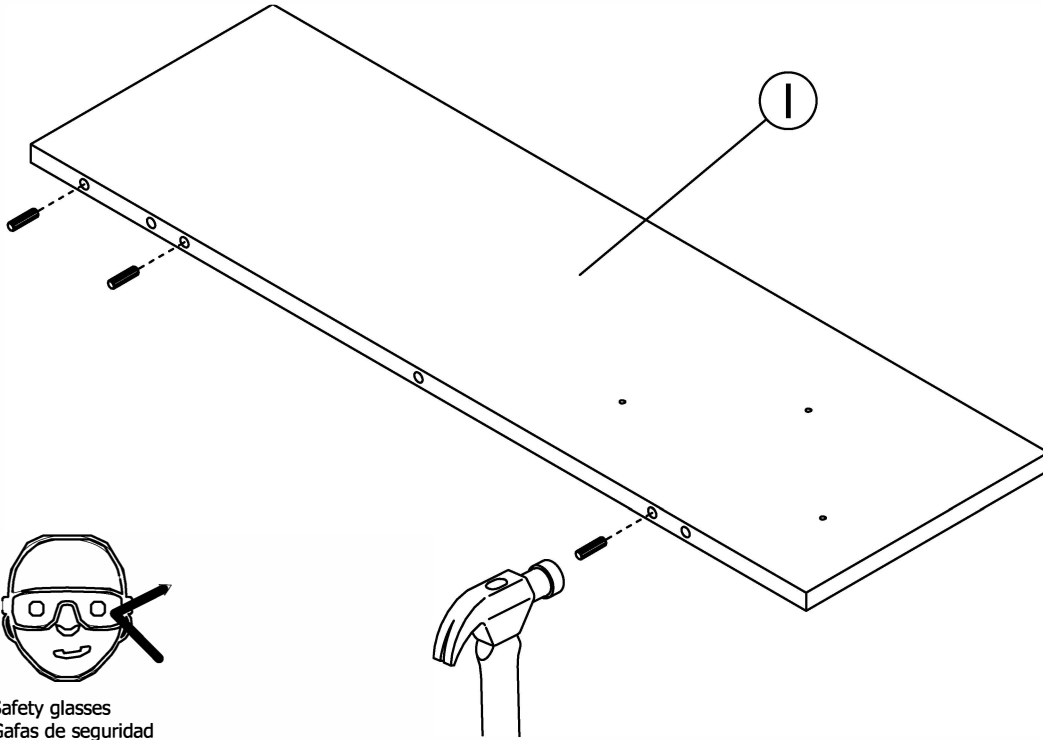

Safety glasses
Gafas de seguridad
Lunettes de protection

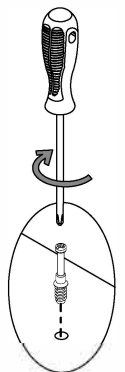
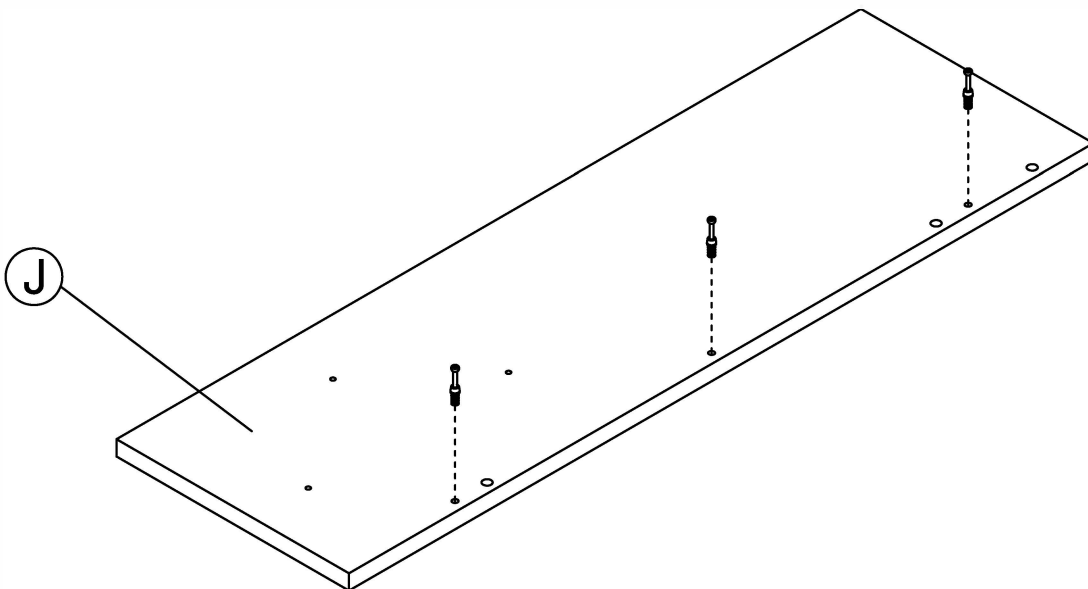

STEP 12

Scan QR Code to Watch Video on:



How to Tighten KD Cams

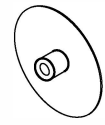
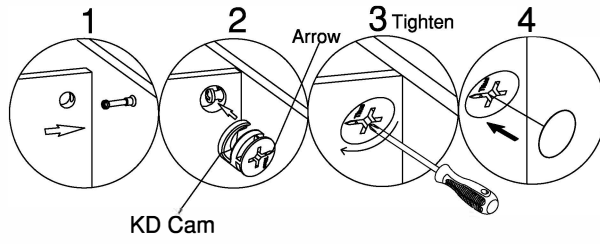

[3]

Cover Cap

H181468

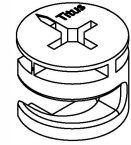

[3]

KD Cam

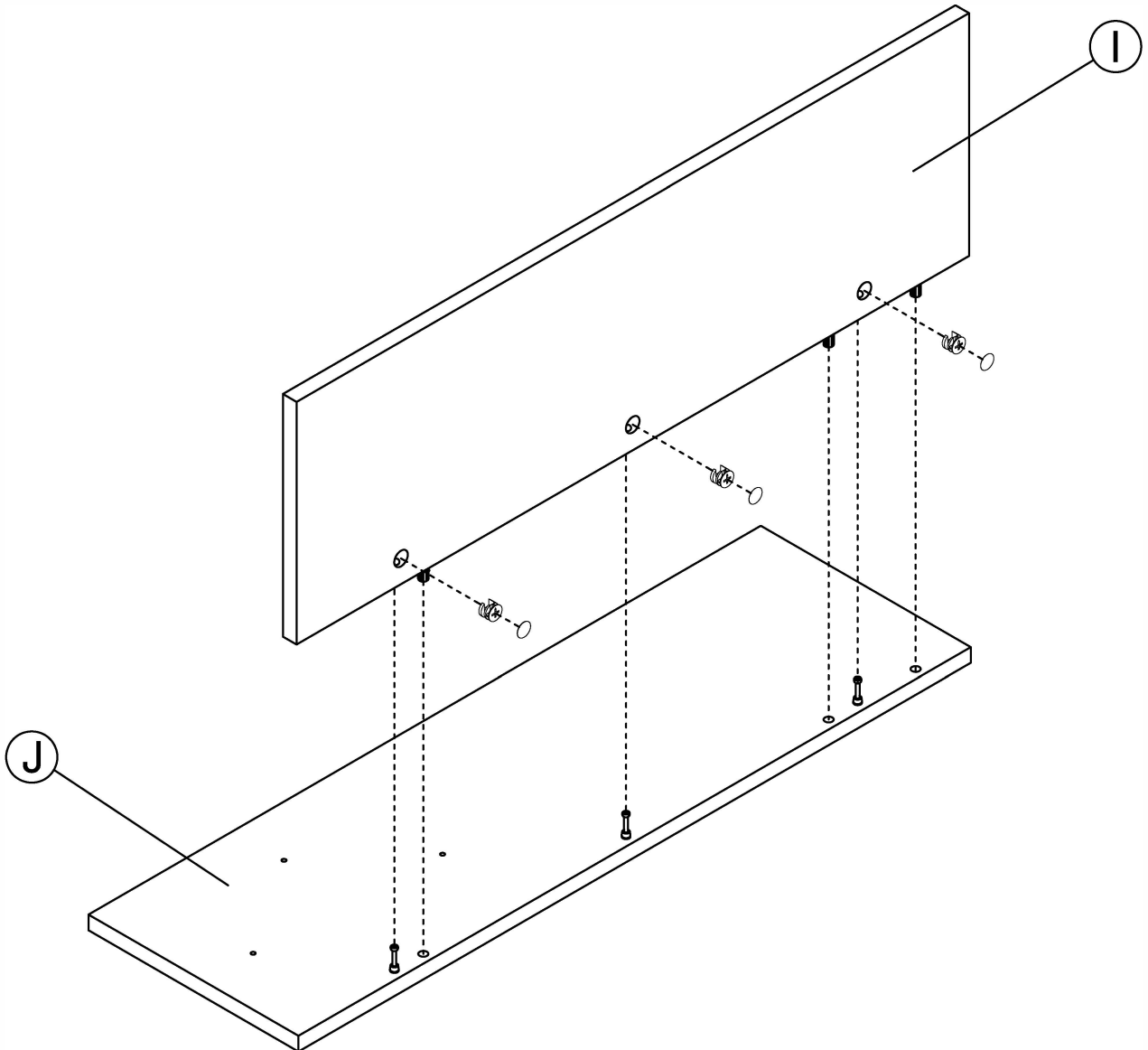

STEP 13

Scan QR Code to Watch Video on:



How to Tighten KD Cams

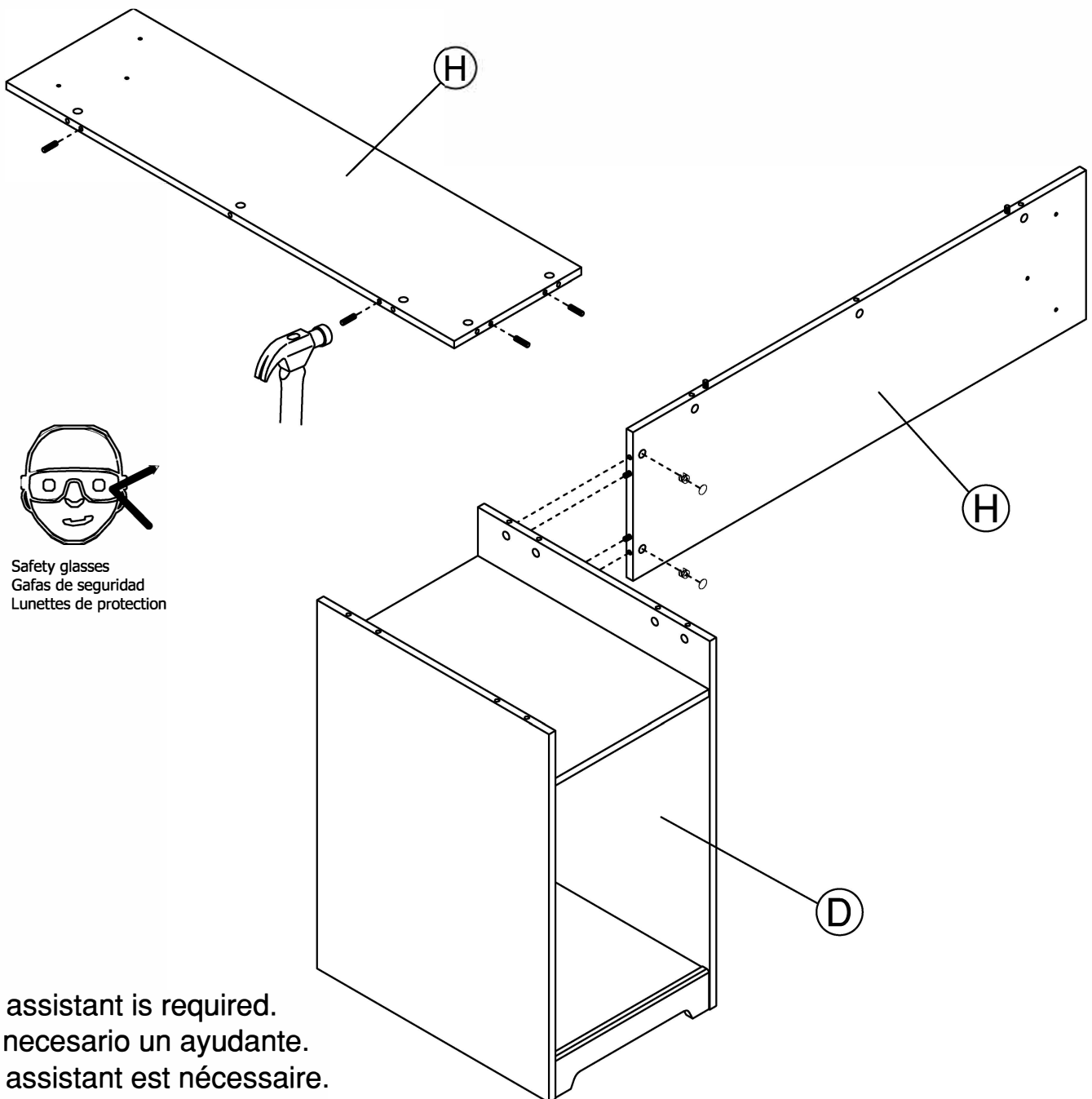
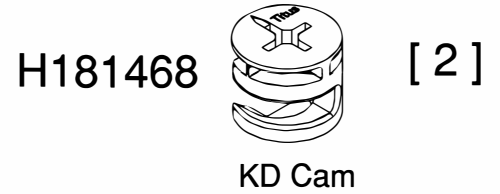
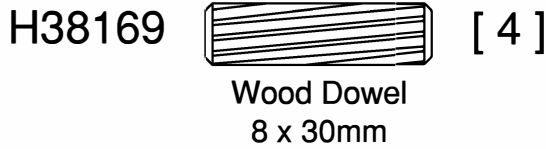
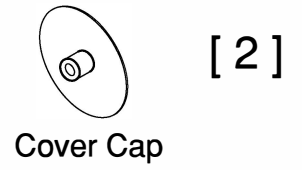
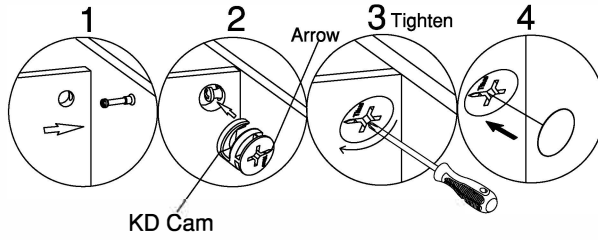

An assistant is required.
Es necesario un ayudante.
Un assistant est nécessaire.

STEP 14

H23682

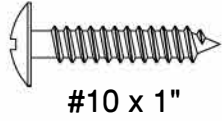

[3]

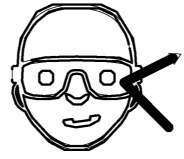

Safety glasses
Gafas de seguridad
Lunettes de protection

An assistant is required.
Es necesario un ayudante.
Un assistant est nécessaire.

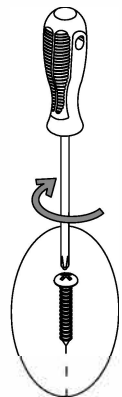
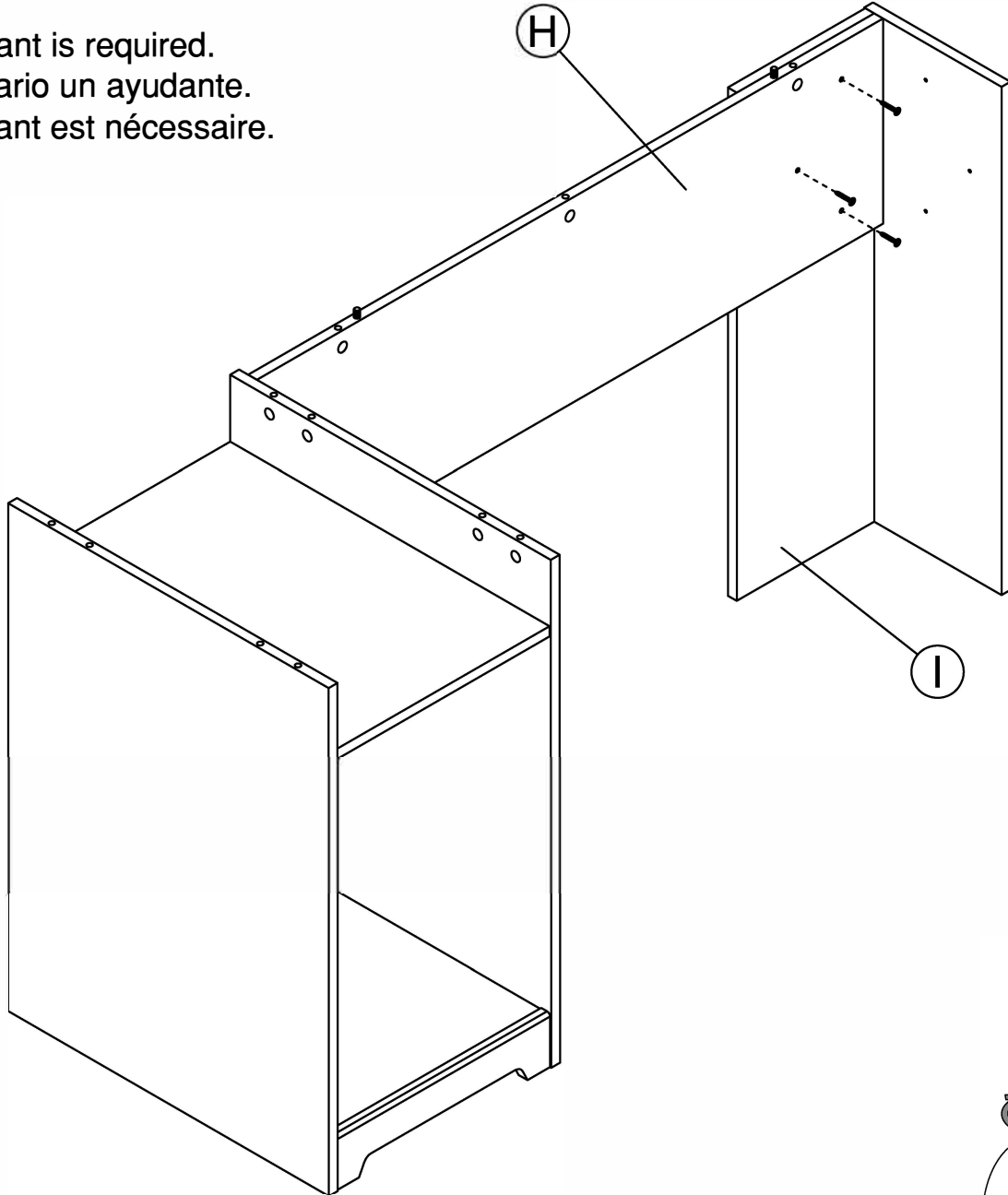

STEP 15

Scan QR Code to Watch Video on:



How to Tighten KD Cams

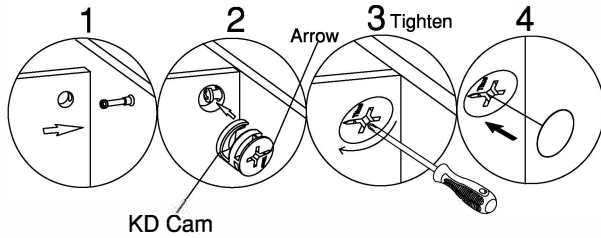

KD Cam

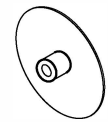

[2]

Cover Cap

H38169



[4]

Wood Dowel
8 x 30mm

H181468



[2]

KD Cam

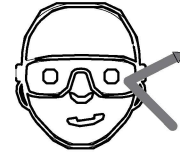
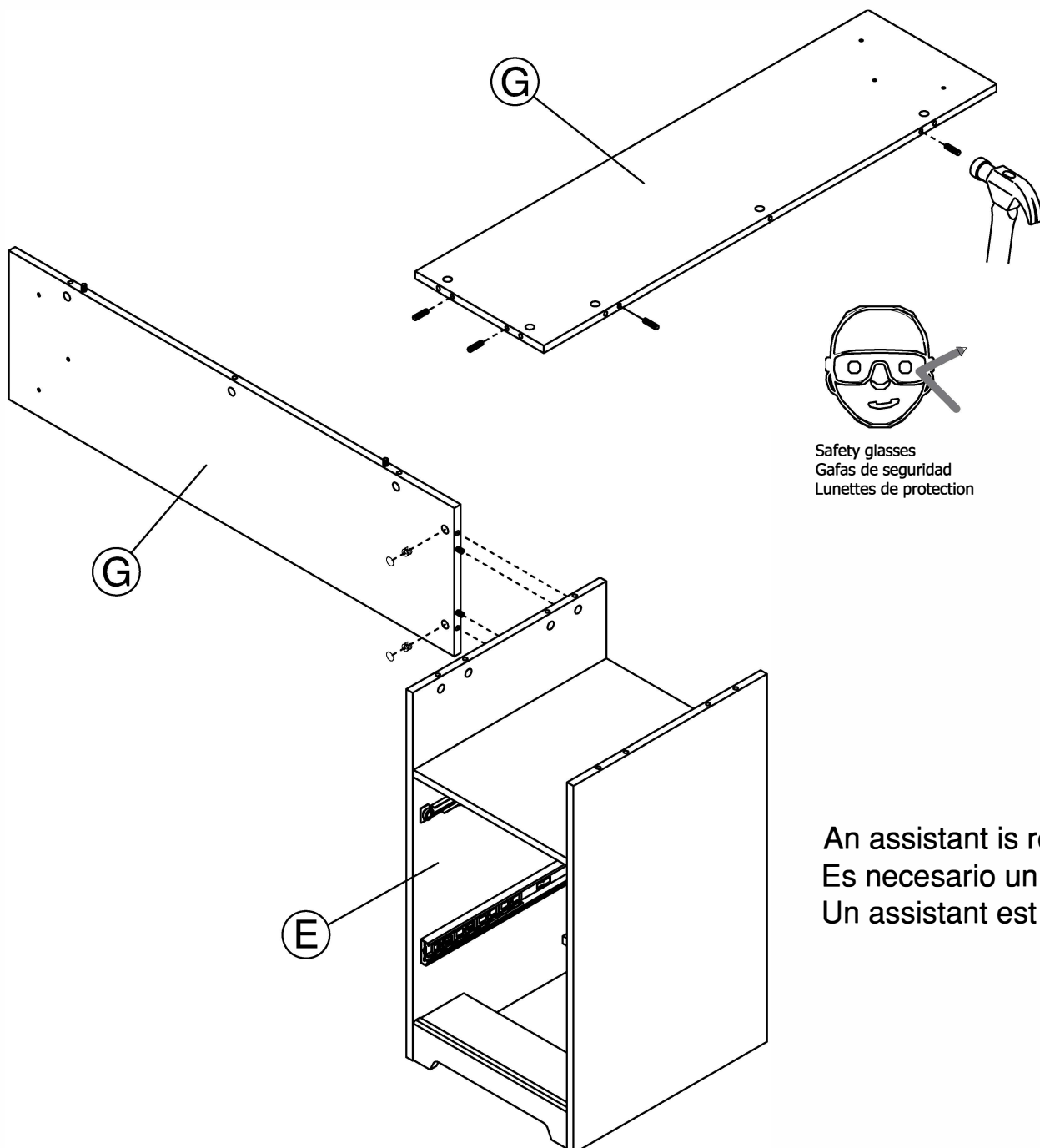

Safety glasses
Gafas de seguridad
Lunettes de protection

An assistant is required.
Es necesario un ayudante.
Un assistant est nécessaire.

STEP 16

H23682

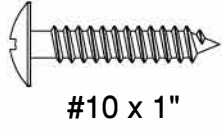

[3]

An assistant is required.
Es necesario un ayudante.
Un assistant est nécessaire.

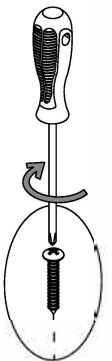
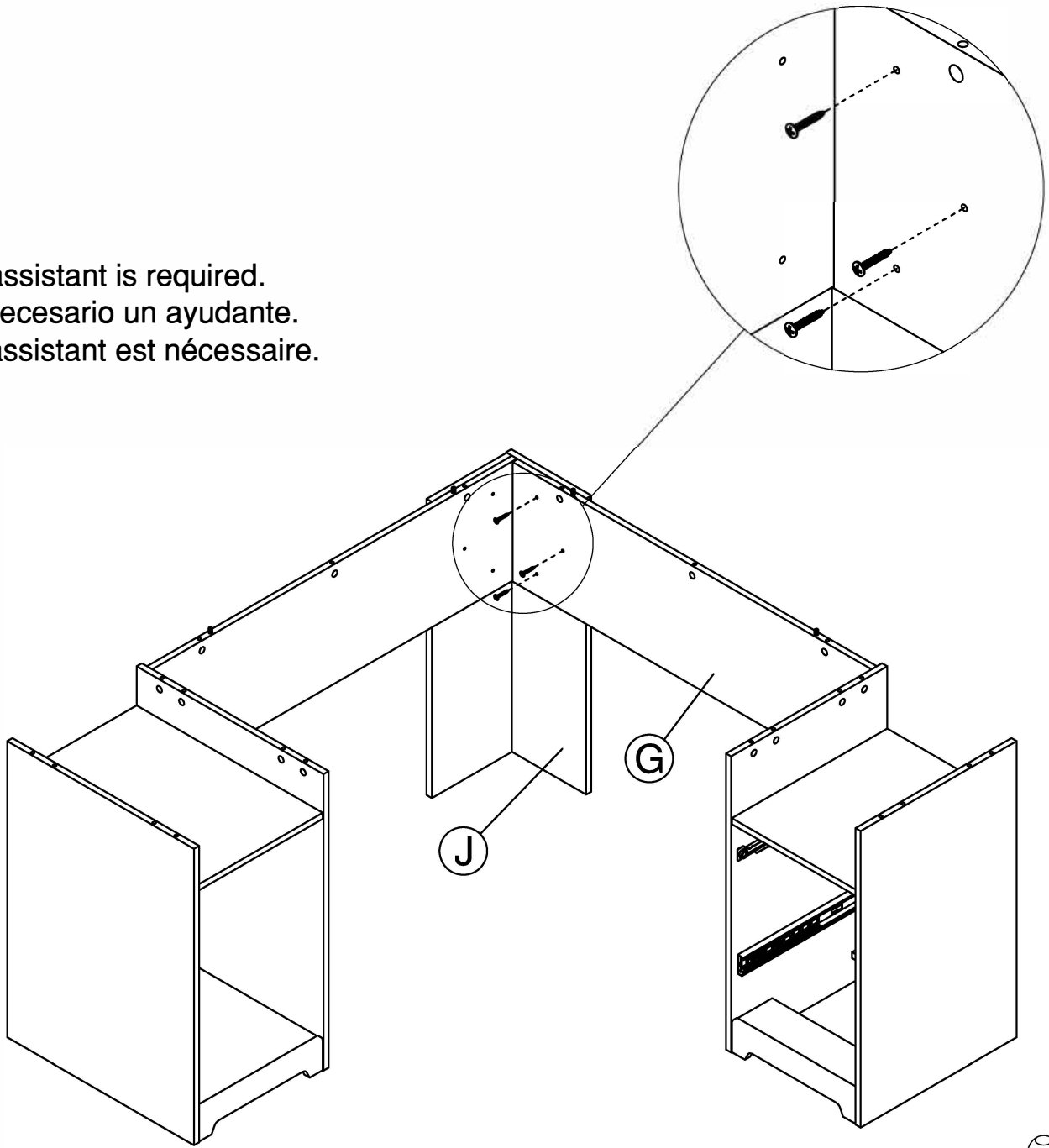

STEP 17

H180604



KD Bolt

[22]

H35251



#10 x 1/2"

[4]

H39922

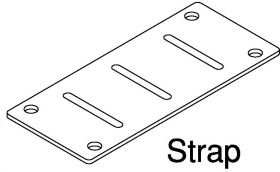

Strap

[2]

H35251

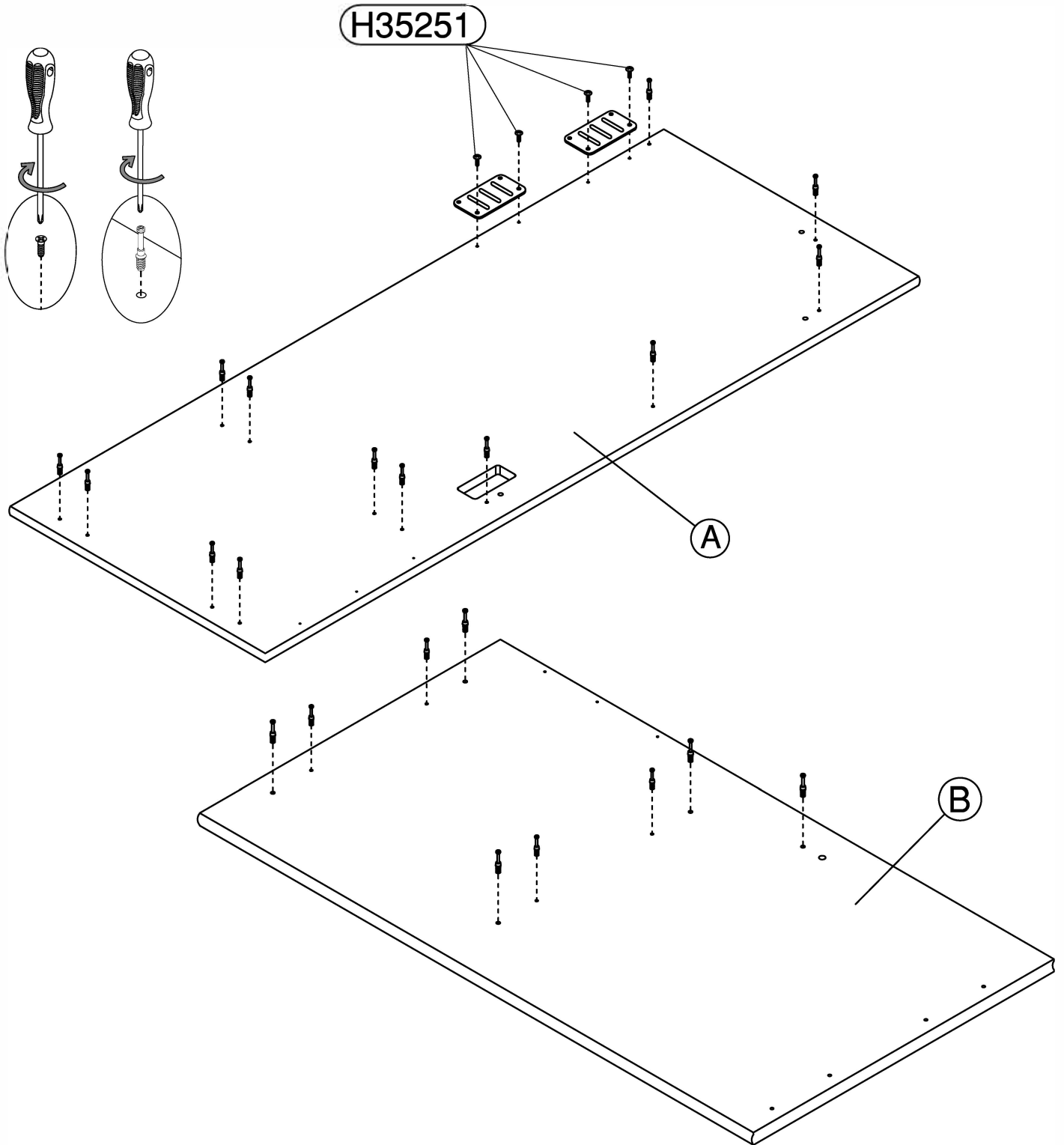

STEP 18

Scan QR Code to Watch Video on:



How to Tighten KD Cams

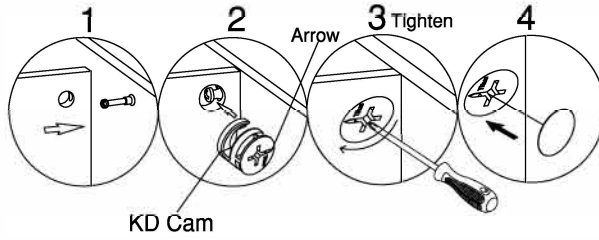

H181468

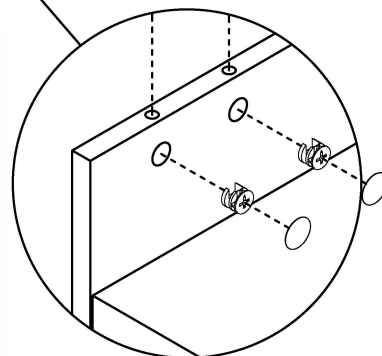
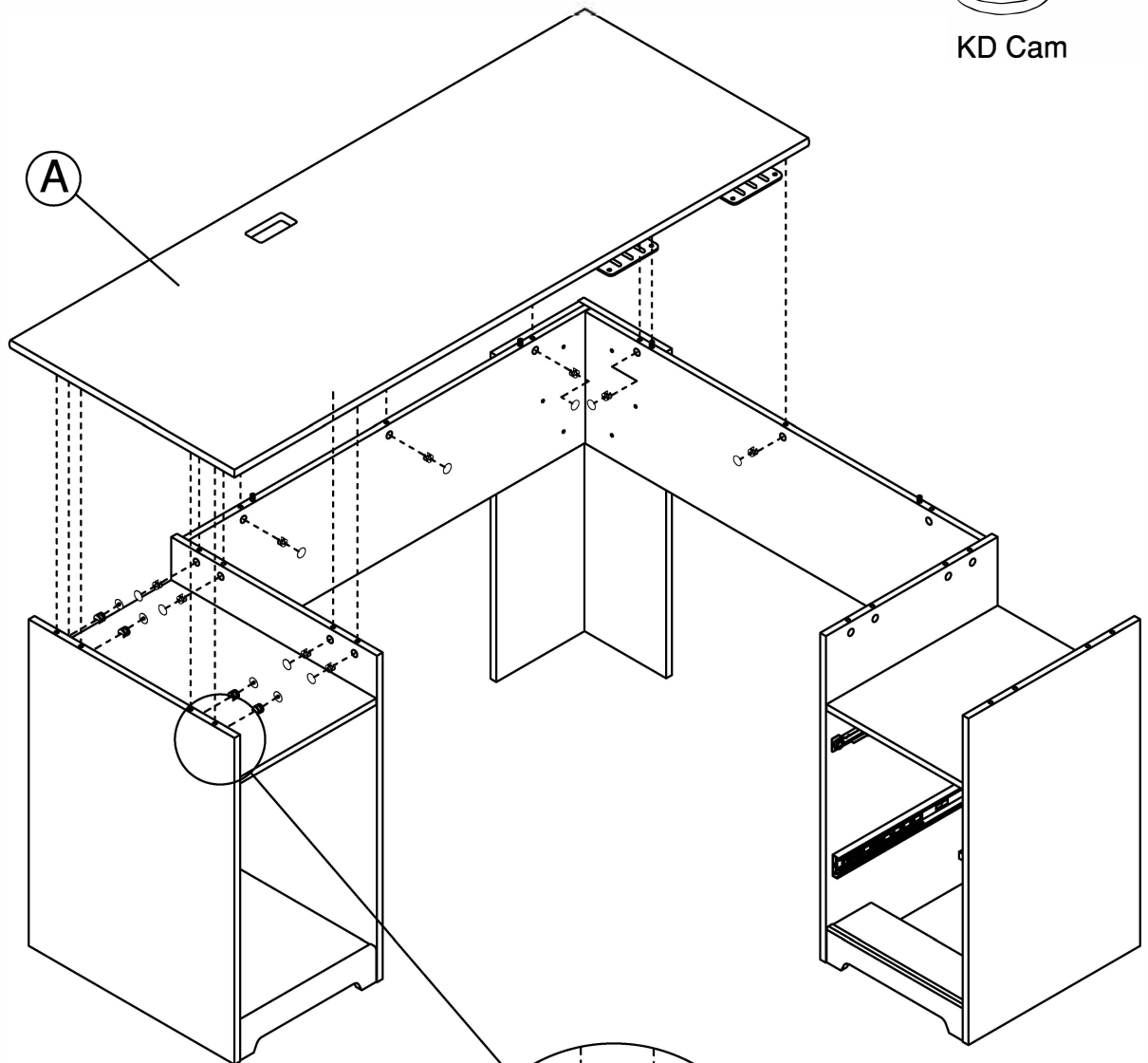
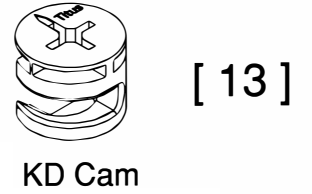

An assistant is required.
Es necesario un ayudante.
Un assistant est nécessaire.

STEP 19

Scan QR Code to Watch Video on:



How to Tighten KD Cams

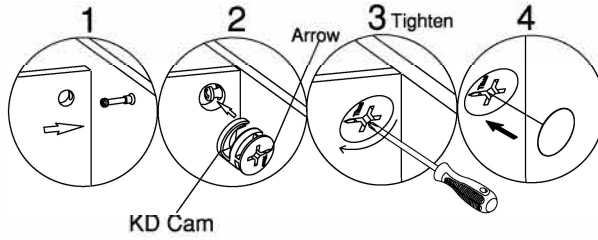

KD Cam



[9]

Cover Cap

H181468

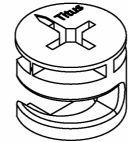

[9]

KD Cam

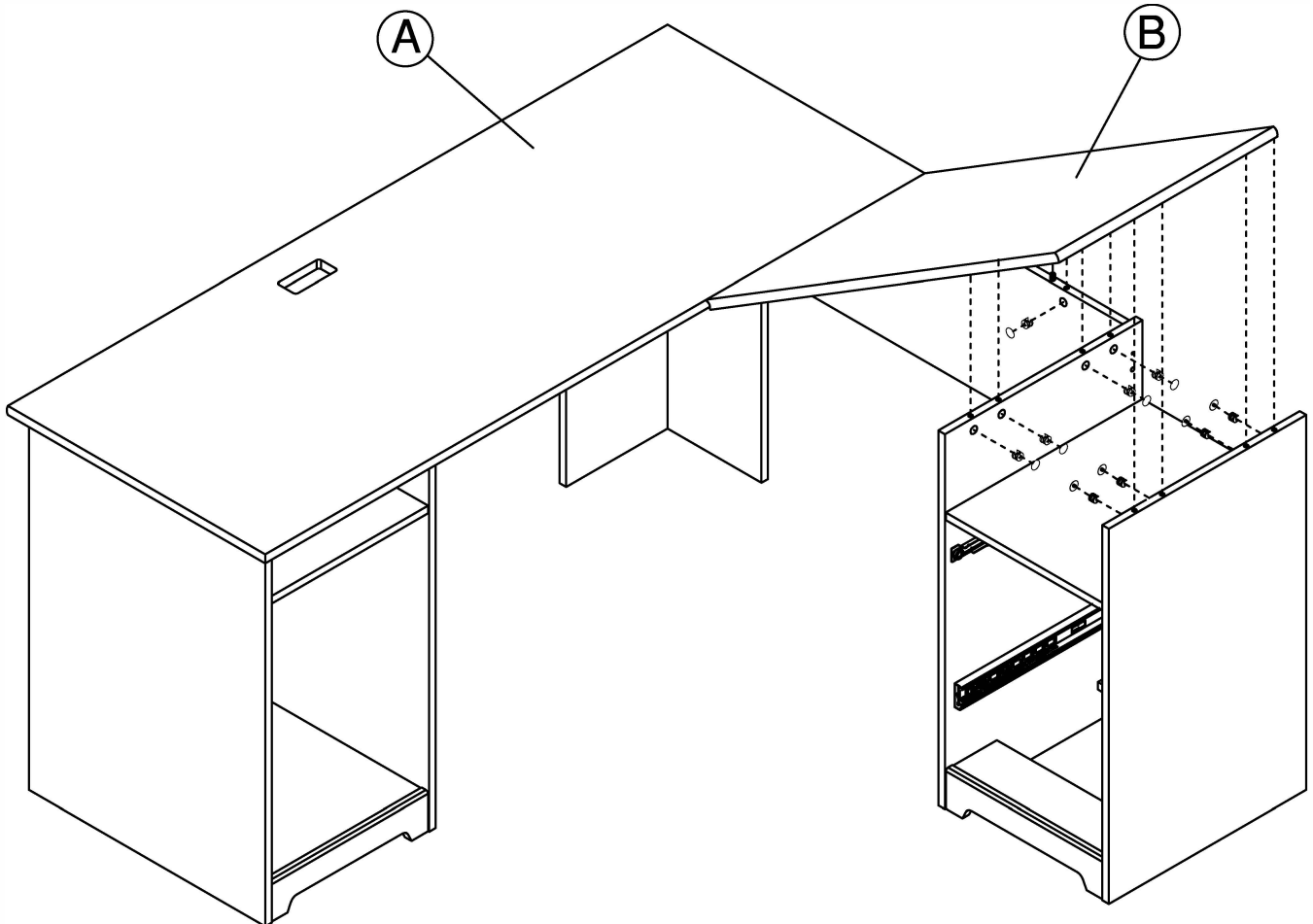

An assistant is required.
Es necesario un ayudante.
Un assistant est nécessaire.

STEP 20

H35251



[4]

#10 x 1/2"

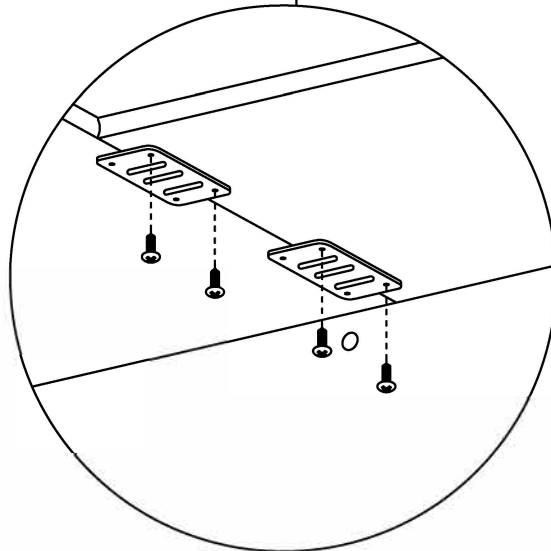
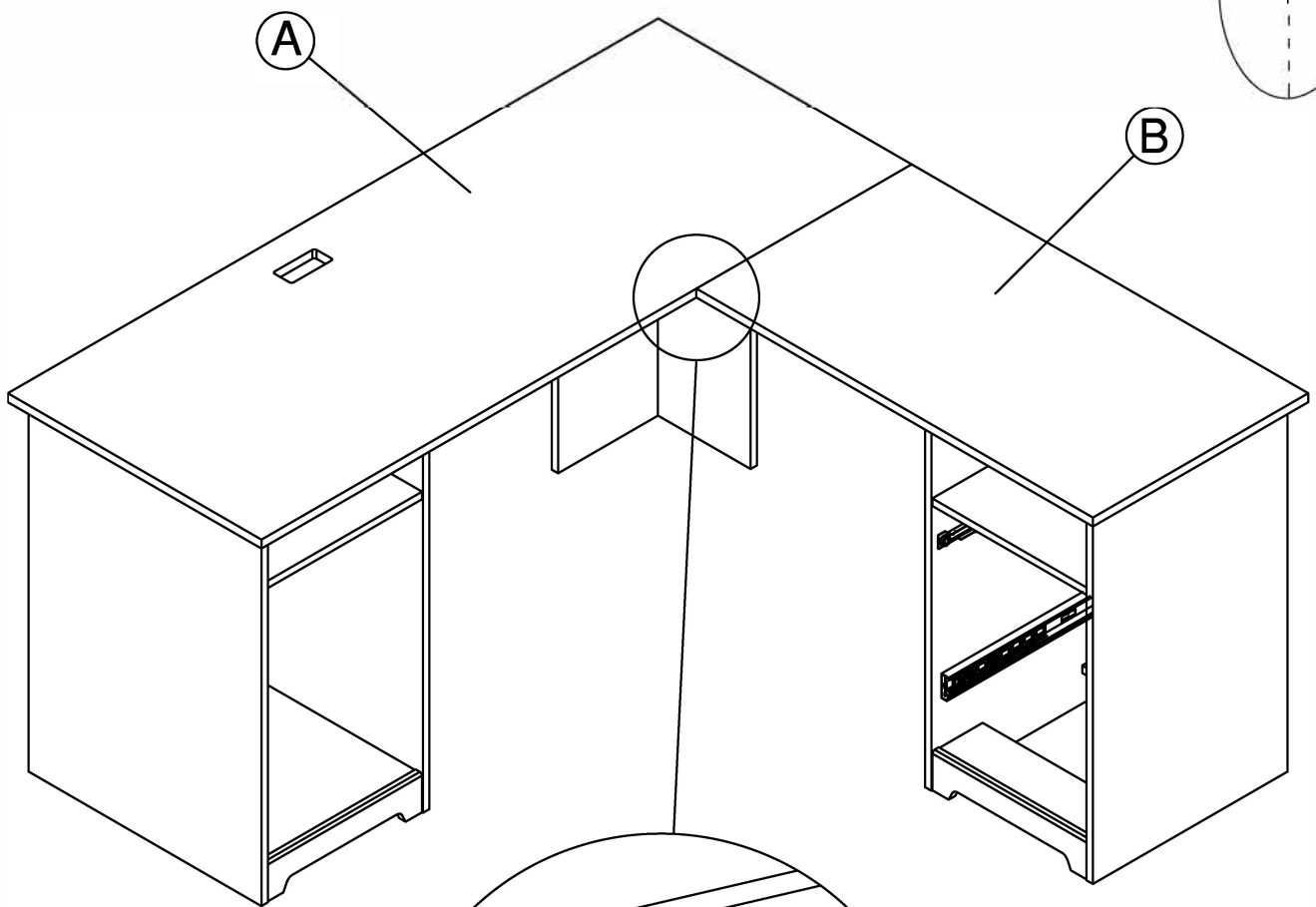
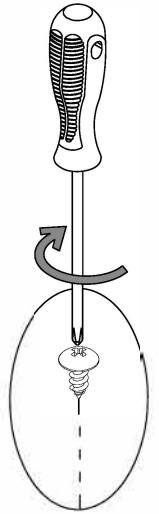

STEP 21

H100445

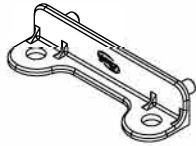

[2]

Drawer Bracket

H100446



[2]

Drawer Bracket

H35251



[8]

#10 x 1/2"

H158943

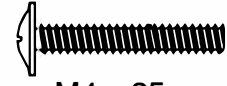

[3]

M4 x 25mm

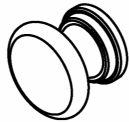

[1]

Pull

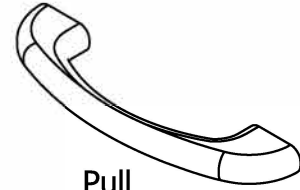

[1]

Pull

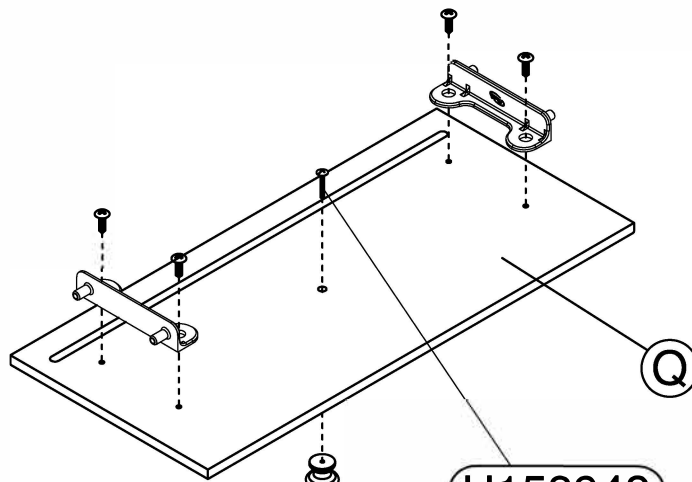

H158943

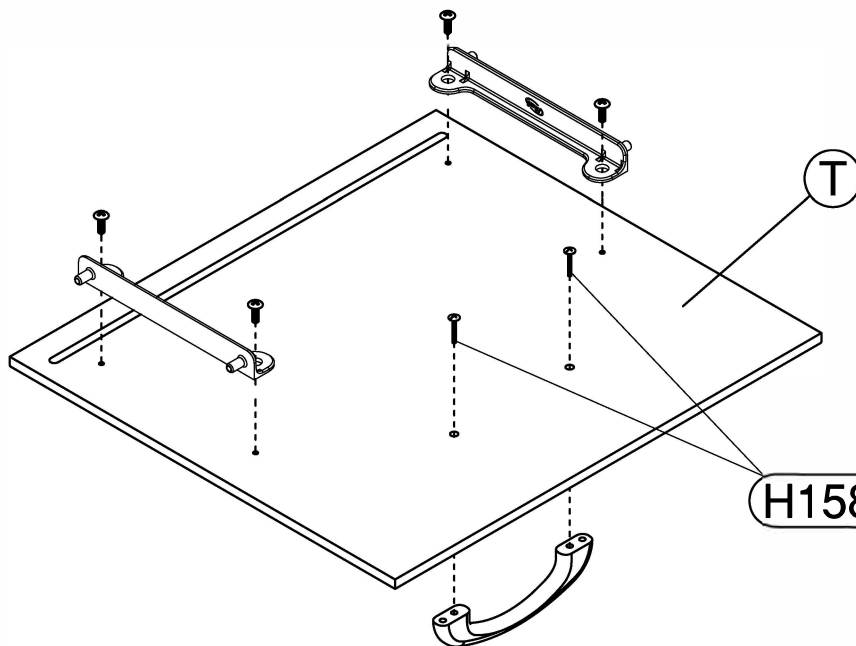
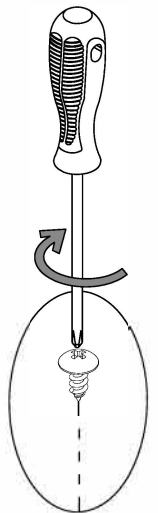

H158943

STEP 23

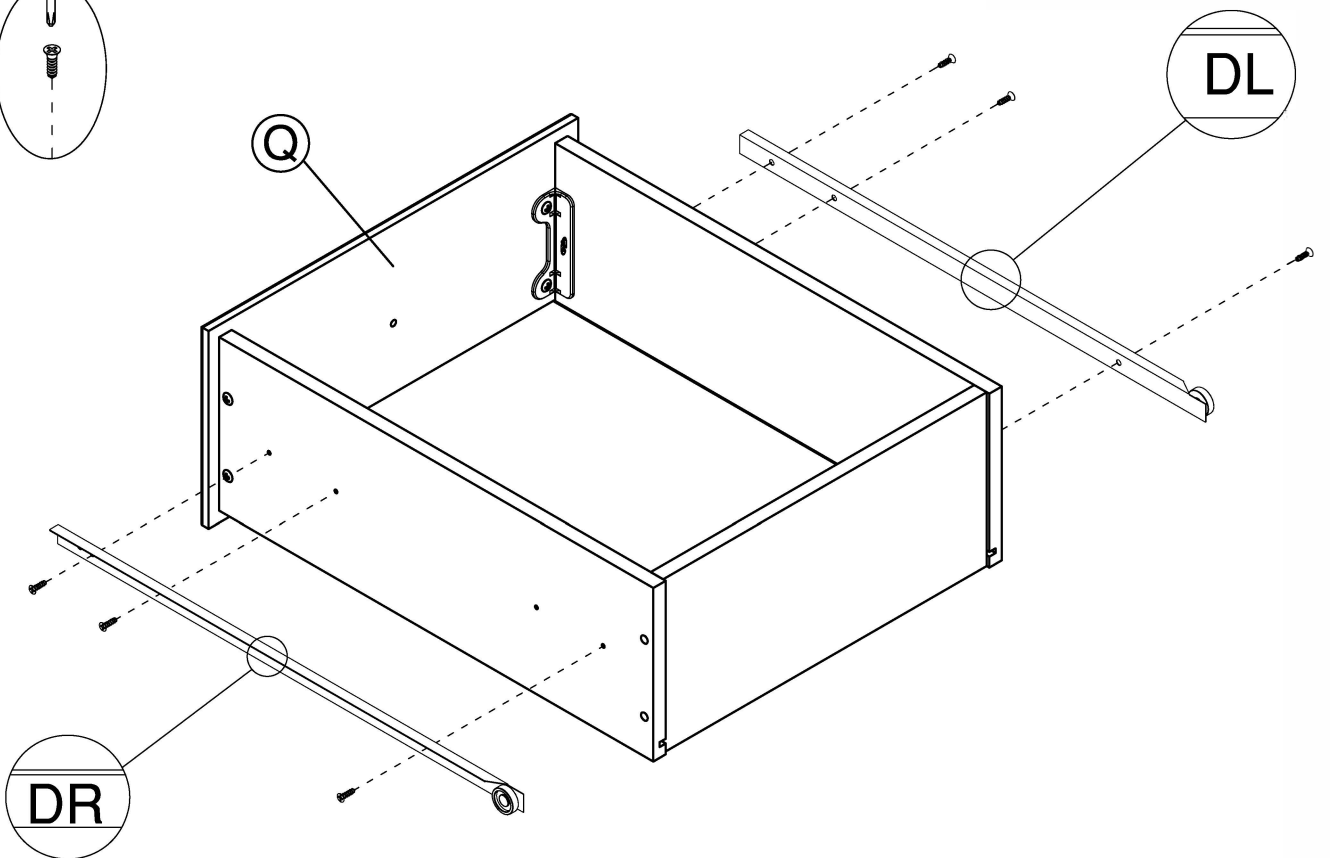
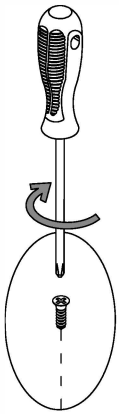
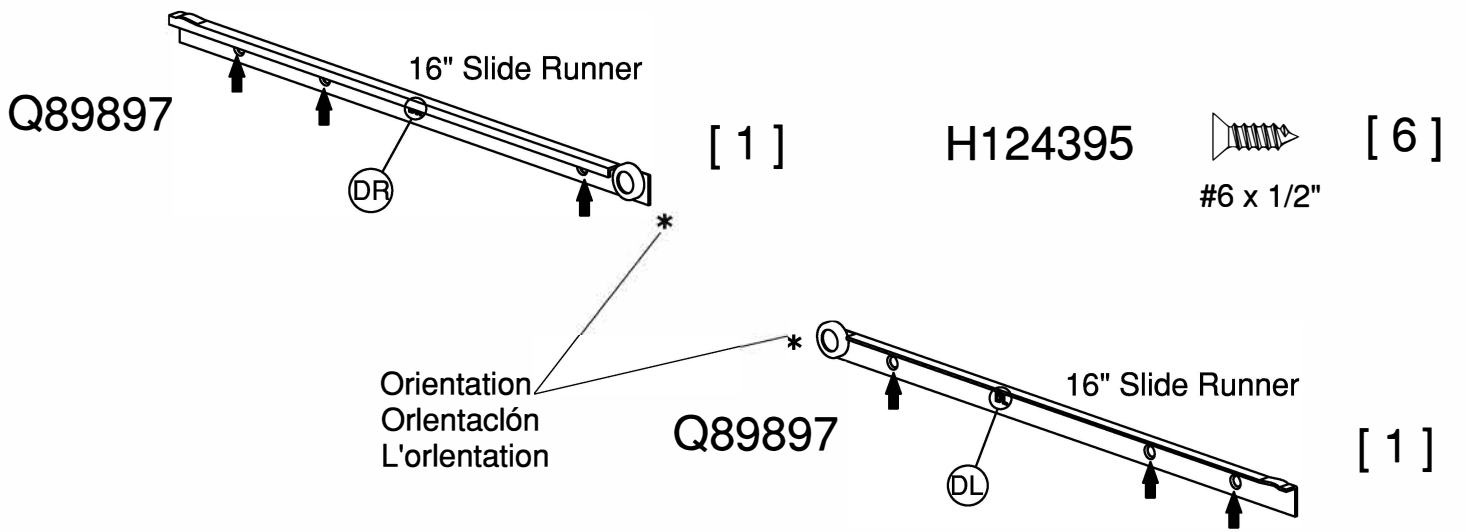

STEP 24

Scan QR Code to Watch Video on:



How to Separate and Install Drawer Slides

H167909

H101725

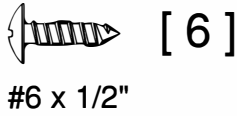
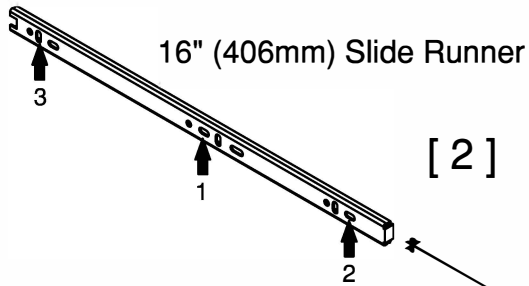

Orientation
Orientación
L'orientation

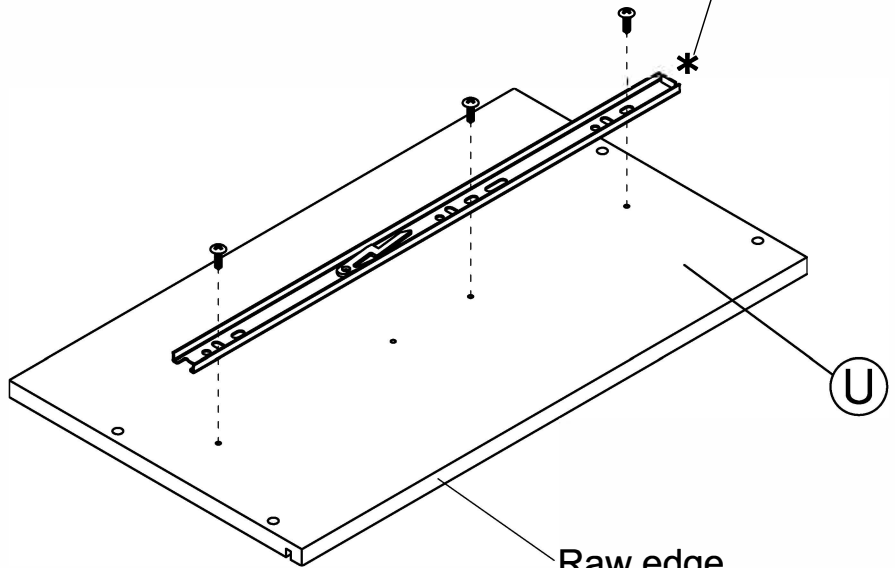

Orientation
Orientación
L'orientation

Raw edge
Orilla sin acabado
Cote brut

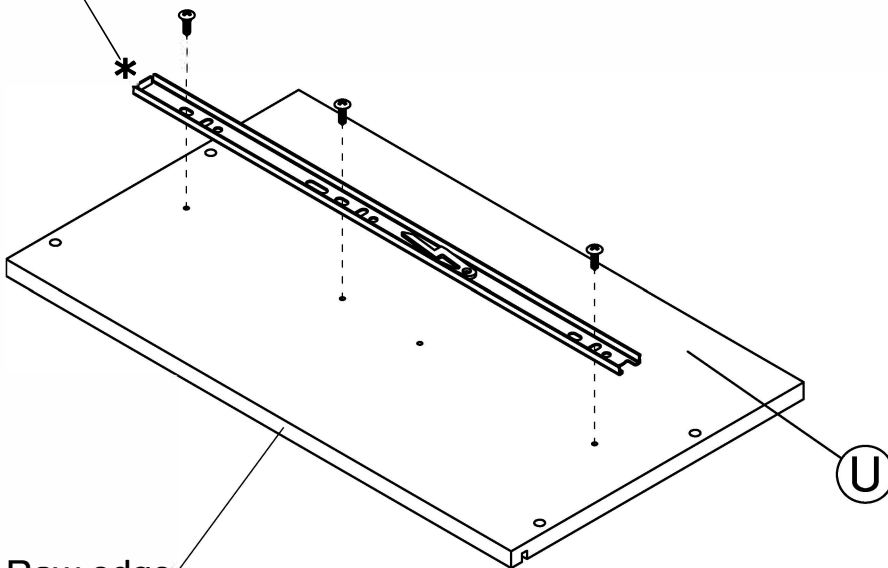

Raw edge
Orilla sin acabado
Cote brut

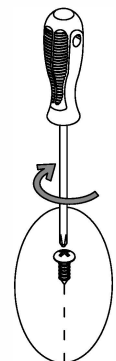

STEP 25

H101725

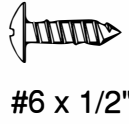

[4]

H26053

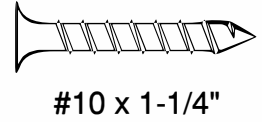

[4]

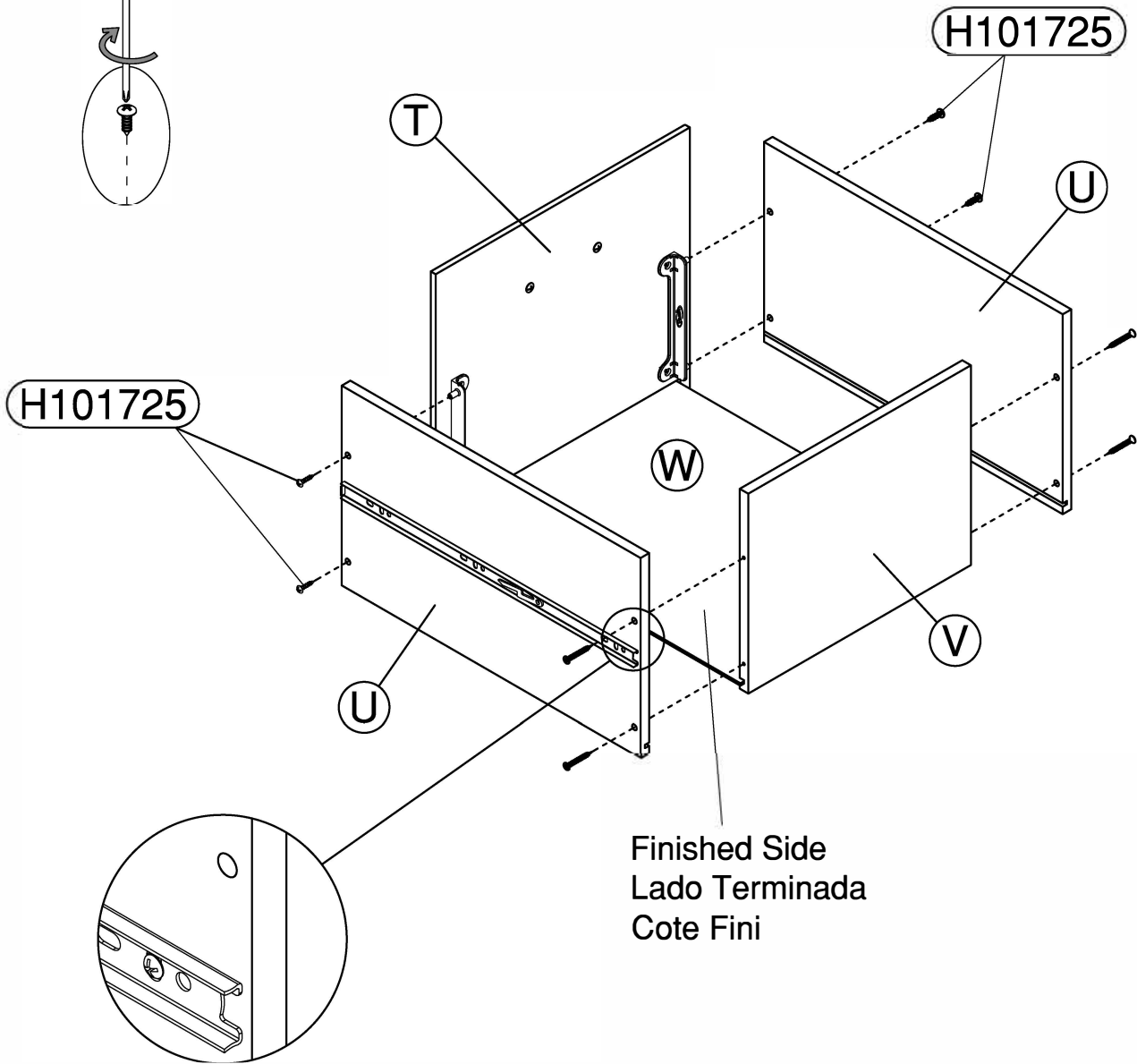
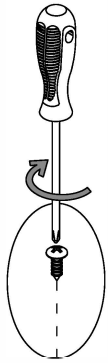

Finished Side
Lado Terminada
Cote Fini

STEP 26

H89793

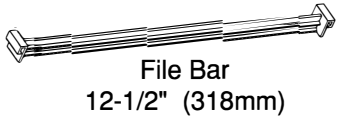

[1]

H153475

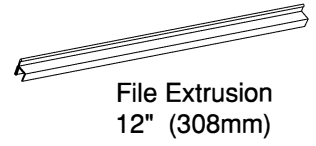

[1]

H158581

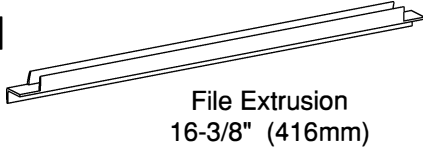

[2]

H158581

H158581

U

U

V

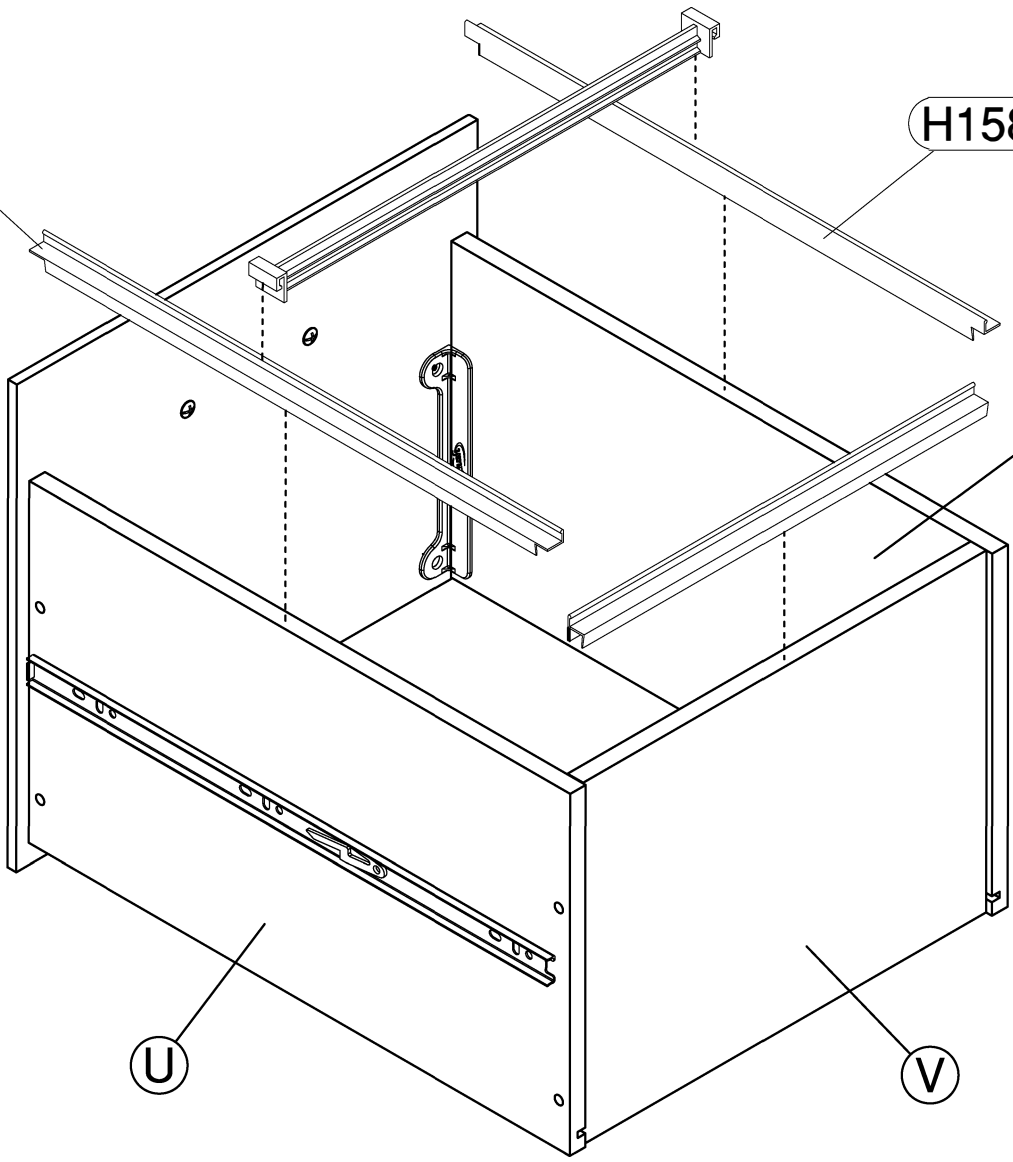

STEP 27

H153242



#8 x 5/8"

[4]

H166299



Hinge

[2]



Pull

[1]

H158943



M4 x 25mm

[1]

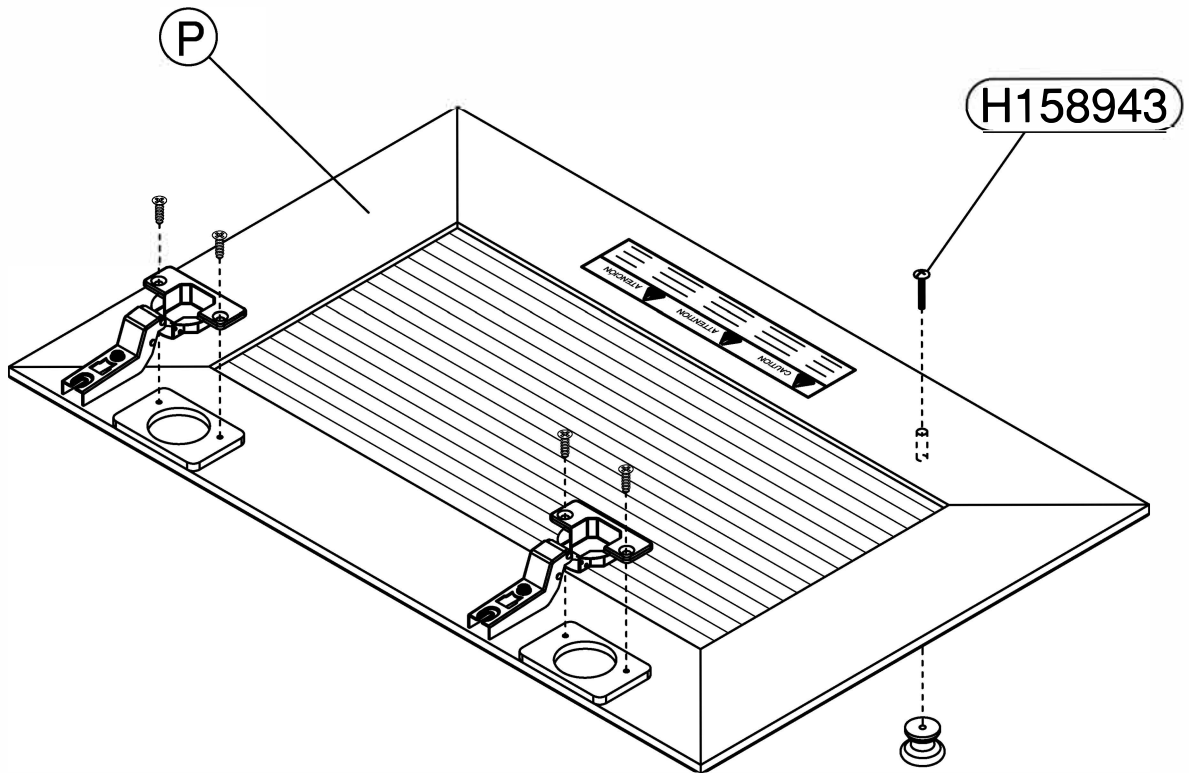
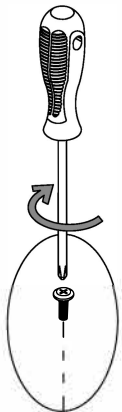

CAUTION



Risk of breaking glass. Handle glass carefully during assembly. Use eye and hand protection. Improper handling can result in cuts or lacerations.

Riesgo de romper el vidrio. Maneje el vidrio con cuidado al ensamblar esta unidad. Use protección para sus ojos y sus manos. El manejo inapropiado del vidrio puede causarle cortaduras o laceraciones.

Risque de bris de verre. Faites attention lors de la manipulation du verre pendant l'assemblage. Utilisez des protections pour les yeux et les mains. Une mauvaise manipulation peut provoquer des coupures ou des lacerations.

STEP 28

Scan QR Code to
Watch Video on:



How to Adjust
Door Hinges

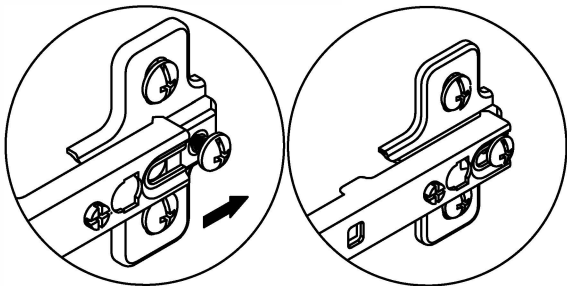
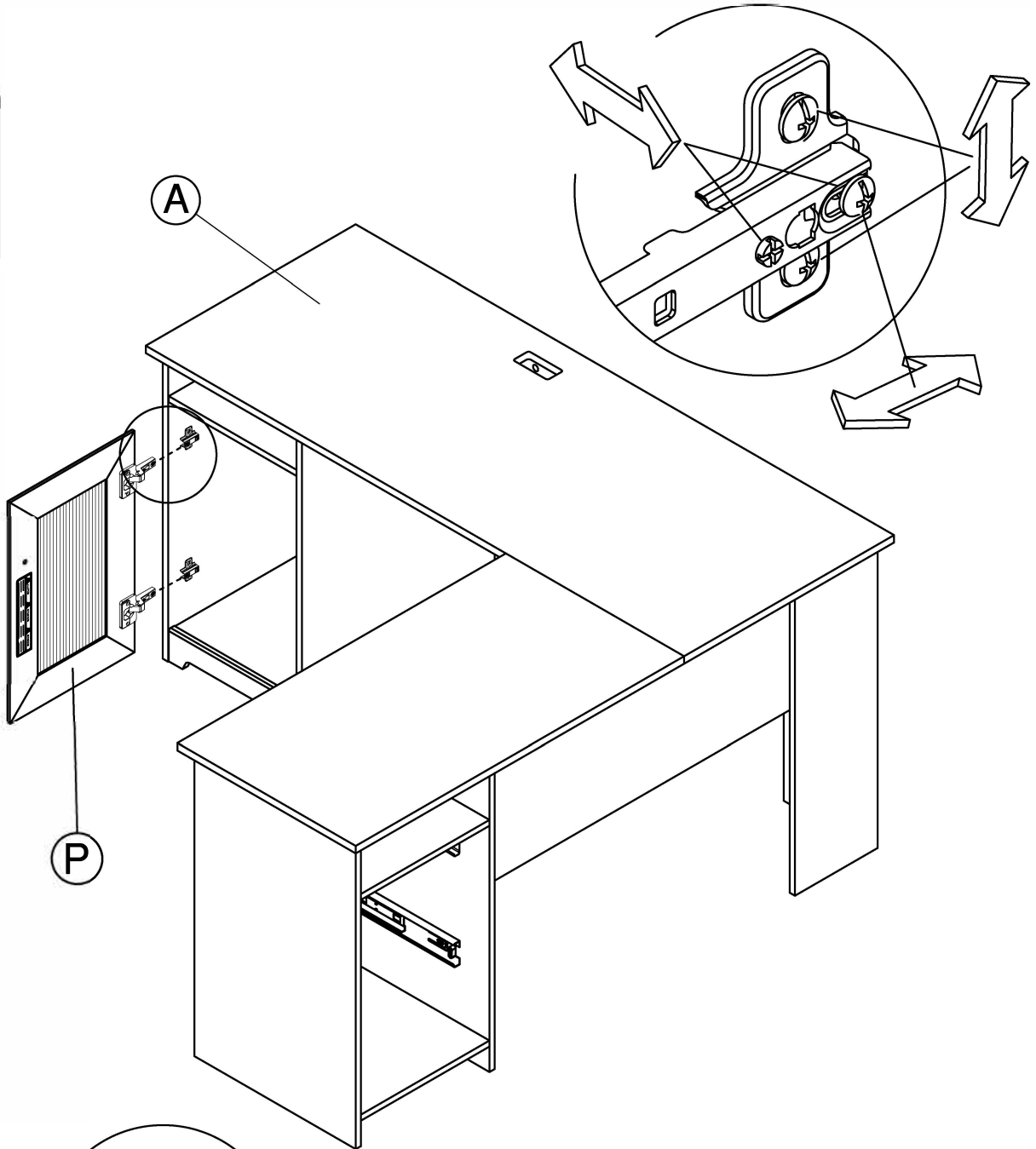

CAUTION

Electronic equipment may overheat causing damage. Do Not store electronic equipment behind doors.



ATTENTION

El equipo electrónico puede sobrecalentarse y causar daños. No almacene equipos electrónicos detrás de las puertas.



ATENCIÓN

L'équipement électronique peut surchauffer et causer des dommages. Ne stockez pas d'équipement électronique derrière des portes.

STEP 29

Scan QR Code to Watch Video on:



How to Separate and Install Drawer Slides

H157520

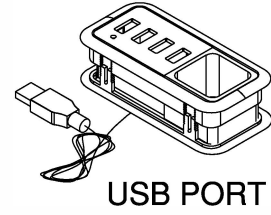

[1]

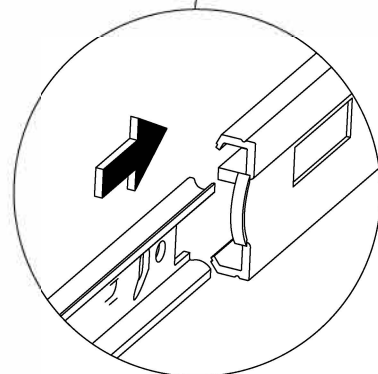
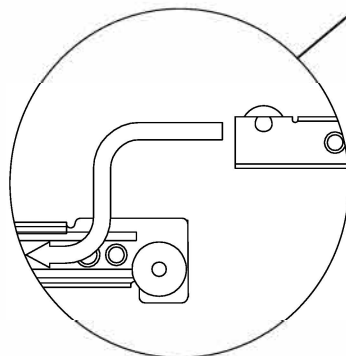
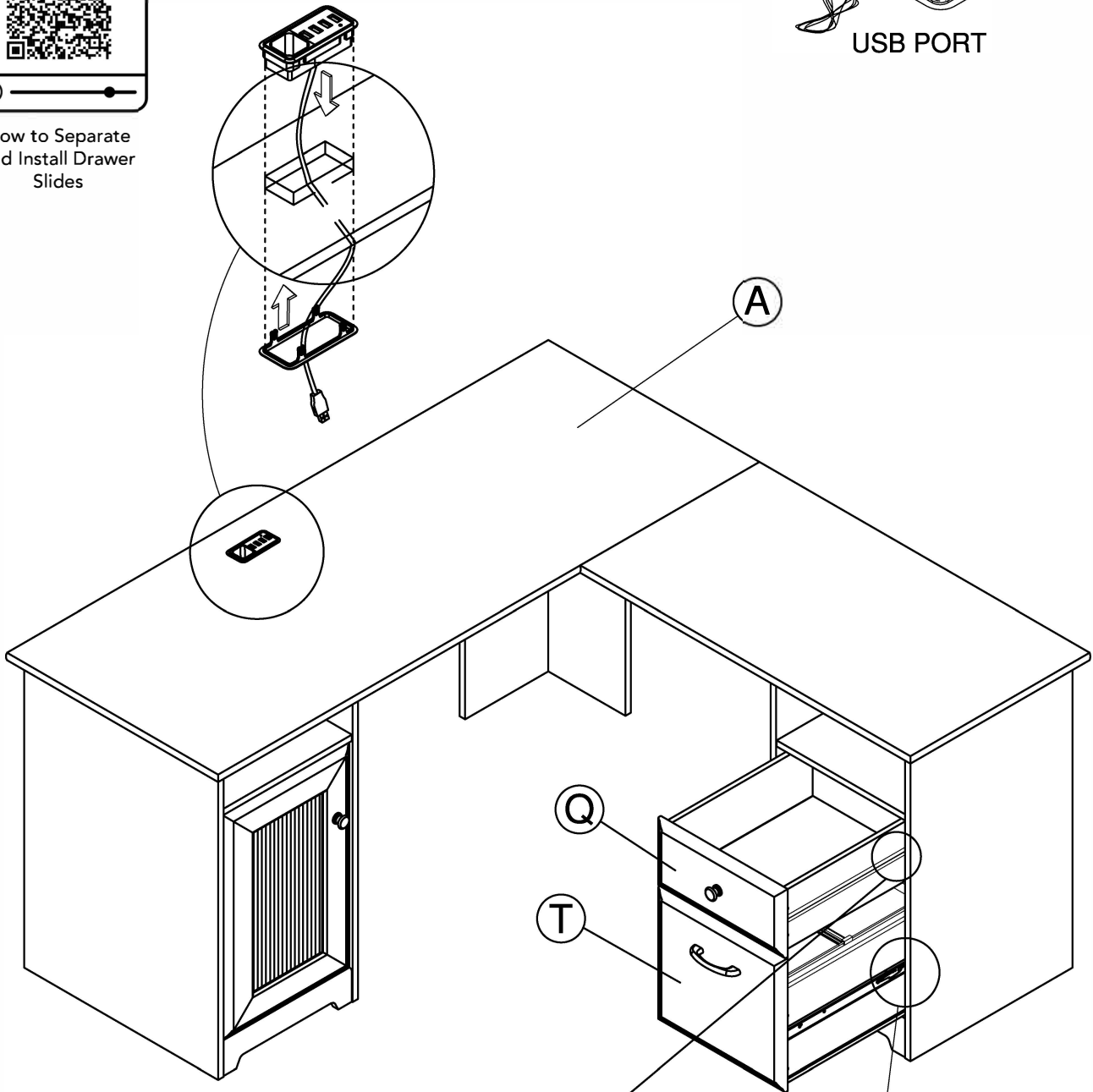

STEP 30



#3 x 3/4"

[40]

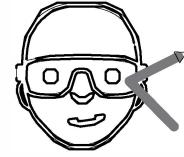

Safety glasses
Gafas de seguridad
Lunettes de protection

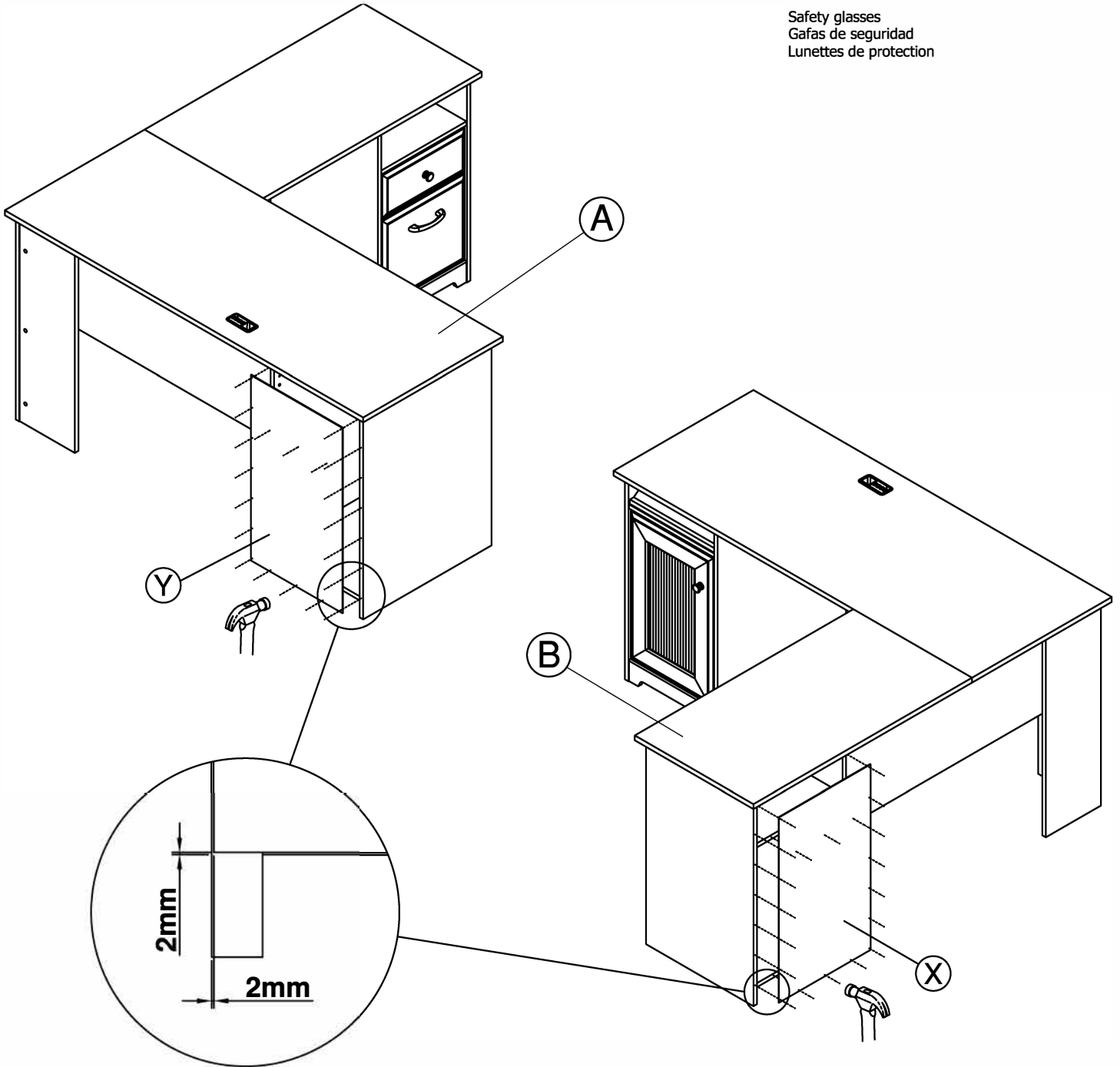

STEP 31

Scan QR Code to Watch Video on:



How to Adjust Drawer Fronts



DRAWER FRONT VIEW

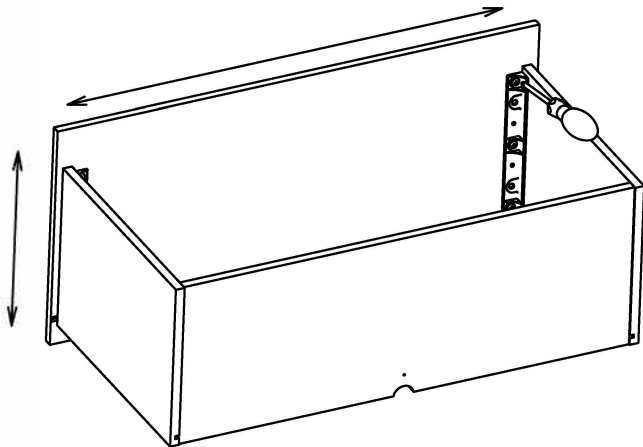
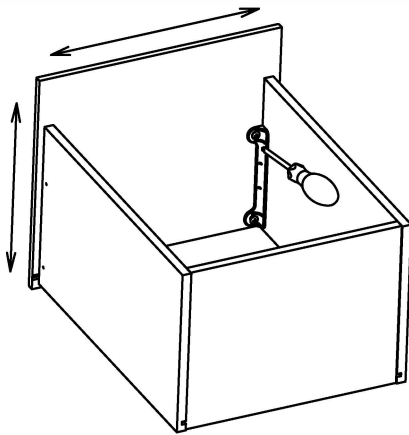
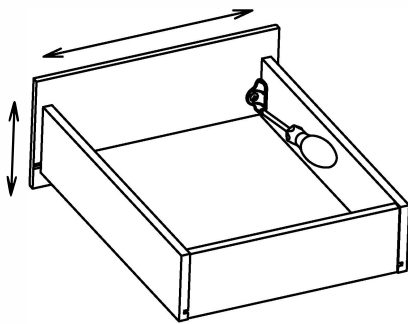
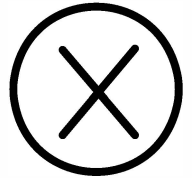
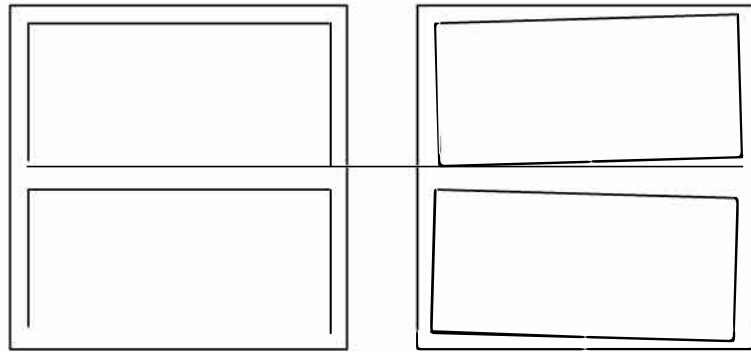

REQUIRED TOOL: PHILLIPS SCREWDRIVER

HERRAMIENTA REQUERIDA: DESTORNILLADOR PHILLIPS
OUTIL REQUIS: TOURNEVIS CRUCIFORME



1. LOOSEN SCREWS.
2. ADJUST DRAWER FRONTS.
3. TIGHTEN SCREWS.

1. Afloje los tornillos
2. Ajustar frentes de cajón
3. Apriete los tornillos

1. Desserrer les vis
2. Ajuster les façades des tiroirs
3. Serrer les vis

THIS PAGE INTENTIONALLY LEFT BLANK

THIS PAGE INTENTIONALLY LEFT BLANK

THIS PAGE INTENTIONALLY LEFT BLANK

WARRANTY INFORMATION/INFORMATIONS POUR LA GARANTIE/INFORMACIÓN DE GARANTÍA

FURNITURE'S WRITTEN WARRANTY TO YOU

In order to provide you with timely assistance, please thoroughly inspect your furniture for missing or defective parts immediately after opening the carton. To receive replacement or missing parts under this warranty, call our Consumer Service Department. Please have the Model, Part, and Lot Numbers found in the instruction manual available for your reference. You will also need your sales receipt or other proof of purchase. Replacement part(s) will be shipped to you at no charge with Industries assuming all ship-ping and handling charges.

This Furniture product is warranted to the original purchaser at the time of purchase and for a period of one year thereafter.

We warrant to you, the original purchaser, that our furniture and all its parts and components are free of defects in material or workmanship. "Defects," as used in this warranty, is defined as any imperfection which impairs the use of the furniture product.

Our warranty is expressly limited to the replacement of furniture parts and components. For one year after the date of purchase, we will replace any parts that are defective in material or workmanship.

This warranty applies under conditions of normal use. Our Furniture products are not intended for outdoor use. This warranty does not cover: 1) defects caused by improper assembly or disassembly; 2) defects occurring after purchase due to product modification, intentional damage, accident, misuse, abuse, negligence or exposure to the elements; and 3) labor or assembly costs.

IMPLIED WARRANTIES, INCLUDING THE WARRANTY OF MERCHANTABILITY, SHALL NOT EXTEND BEYOND THE DURATION OF THE WRITTEN WARRANTY STATED ABOVE, AND IN NO EVENT SHALL WE BE LIABLE FOR INCIDENTAL OR CONSEQUENTIAL DAMAGES RESULTING FROM USE OF THE PRODUCT. Some states do not allow a limitation on how long an implied warranty lasts or the exclusion or limitation of incidental or consequential damages, so the above limitation and exclusion may not apply to you.

This warranty gives you specific legal rights. You may also have other rights that may vary from state to state.

VOTRE GARANTIE FURNITURE

Afin de vous assister rapidement, veuillez inspecter votre mobilier en détail immédiatement après l'ouverture du carton en cas de pièces manquantes ou défectueuses. Pour recevoir une pièce de rechange ou manquante couverte par cette garantie, appelez notre département de service clientèle GRATUITEMENT. Veuillez tenir à disposition les numéros de modèle, de pièce et de lot qui se trouvent dans le manuel d'instruction pour votre référence. Vous aurez également besoin de votre reçu ou d'une autre preuve d'achat. La (les) pièce(s) de rechange vous sera (seront) envoyée(s) sans frais, Industries se chargeant de tous les frais d'expédition.

Tout le produit Furniture est garanti à l'acheteur original à partir de la date d'achat pour une période d'un an.

Nous vous garantissons, à vous l'acheteur original, que notre mobilier et toutes ses pièces et composants sont sans défaut de matériau ou de fabrication. Le terme "défauts" utilisé dans cette garantie, est défini comme étant toutes les imperfections qui compromettent l'utilisation du meuble.

Notre garantie est expressément limitée au remplacement des pièces et des composants du mobilier. Pendant un an après la date d'achat, nous remplacerons toute pièce défectueuse dans le matériau ou sa fabrication.

Cette garantie d'applique sous des conditions d'utilisation normale. Nos produits ne sont pas destinés à être utilisés en plein air. Cette garantie ne couvre pas: 1) les défauts causés par un mauvais assemblage ou démontage, 2) les défauts ayant lieu après l'achat et dus à la modification du produit, des dommages intentionnels, des accidents, une mauvaise utilisation, un mauvais traitement, la négligence ou l'exposition aux éléments, et 3) les frais de main d'œuvre ou d'assemblage.

LES GARANTIES TACITES, Y COMPRIS LA GARANTIE DE QUALITE MARCHANDE, NE S'ETENDRONT PAS AU-DELA DE LA DUREE ECRITE CITEE CI-DESSUS, ET NE SERA EN AUCUN CAS RESPONSABLE DES DOMMAGES ACCESSOIRES OU INDIRECTS RESULTANT DE L'UTILISATION DU PRODUIT. Certains états ne permettent pas d'appliquer une limite à la durée de la garantie tacite, ni une exclusion ou limitation des dommages accessoires ou indirects; dans ce cas les limitations ou exclusion ci-dessus peuvent ne pas s'appliquer à vous.

Cette garantie vous donne des droits légaux spécifiques. Il se peut que vous ayez également d'autres droits qui peuvent varier d'un état à l'autre.

GARANTIA ESCRITA DE FURNITURE PARA USTED

Para brindarle asistencia oportuna, por favor, verifique detalladamente que a su mueble no le falte o tenga piezas defectuosas inmediatamente después de abrir la caja. Para recibir un reemplazo o la parte faltante bajo esta garantía, llame a nuestro Departamento de Servicio al Consumidor GRATIS. Sírvase traer los números de modelo, parte y lote que se encuentran en el manual de instrucciones disponible para su referencia. Además, necesitará el recibo de su compra u otra prueba de compra. La(s) pieza(s) de reemplazo le será(n) enviada(s) sin recargo por Industries asumiendo los gastos de envío y manipuleo.

Todo mueble de Furniture es garantizado al comprador original al momento de la compra y por un periodo de uno año en adelante.

Le garantizamos a usted, el comprador original, que nuestros muebles sus partes y componentes están libres de defectos en materiales o trabajo. "Defectos", según se usa en esta garantía, se define como una imperfección que perjudica el uso del producto mobiliario.

Nuestra garantía se limita expresamente al reemplazo de partes y componentes mobiliarios. Durante uno año después de la fecha de compra, reemplazará cualquier parte defectuosa en material o trabajo.

Esta garantía se aplica bajo condiciones de uso normal. Nuestros productos de Furniture no son para uso en exteriores. Esta garantía no cubre: 1) defectos causados por un ensamblaje o desensamblaje inadecuado; 2) defectos que ocurran después de la compra debido a modificación del producto, daño intencional, accidente, mal uso, abuso, negligencia o exposición a los elementos; y 3) costos de trabajo o ensamblaje.

LAS GARANTÍAS IMPLICADAS, INCLUYENDO LA GARANTÍA DE COMERCIABILIDAD, NO SE EXTENDERÁN MÁS ALLÁ DE LA DURACIÓN DE LA GARANTÍA ESCRITA MENCIONADA, Y EN NINGÚN CASO SERÁ RESPONSABLE POR DAÑOS INCIDENTALES O CONSIGUIENTES COMO RESULTADO DEL USO DEL PRODUCTO. Algunos estados no permiten una limitación sobre el tiempo de duración de la garantía implicada o la exclusión o limitación de daños incidentales o consiguientes, de manera que la limitación y exclusión mencionadas pueden no aplicarse para usted.

Esta garantía le otorga derechos legales específicos. Puede también tener otros derechos que pueden variar según los estados.

1-Year
Manufacturer's
Warranty