

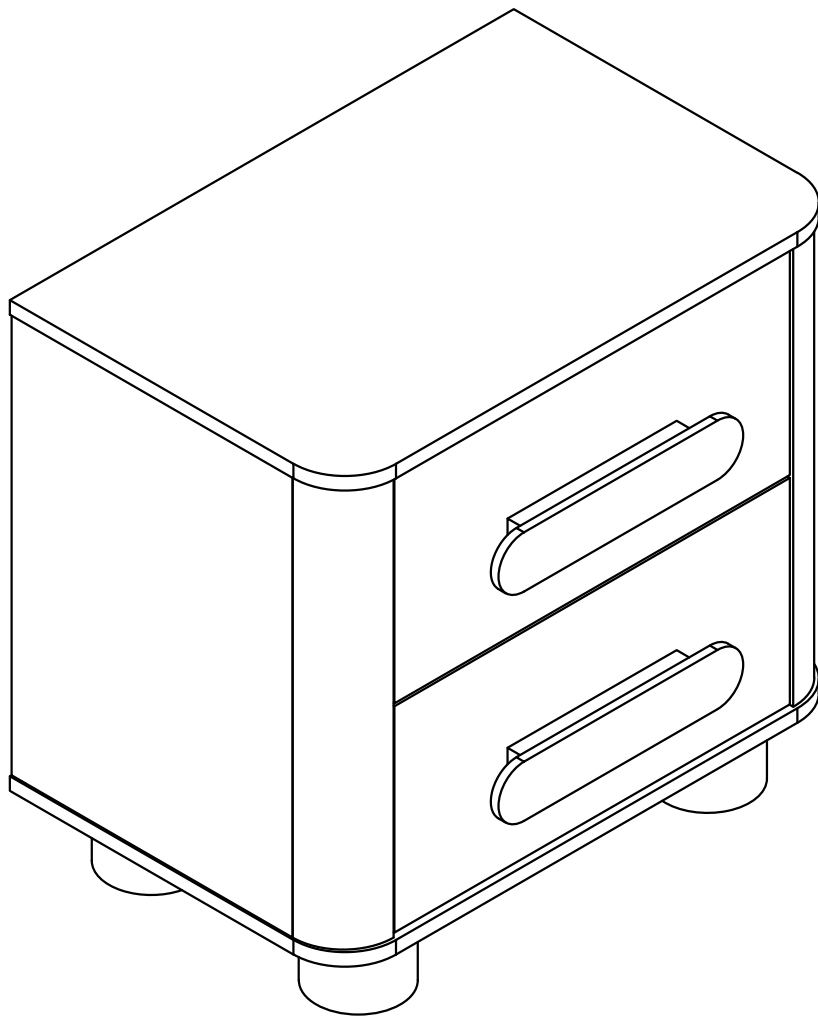

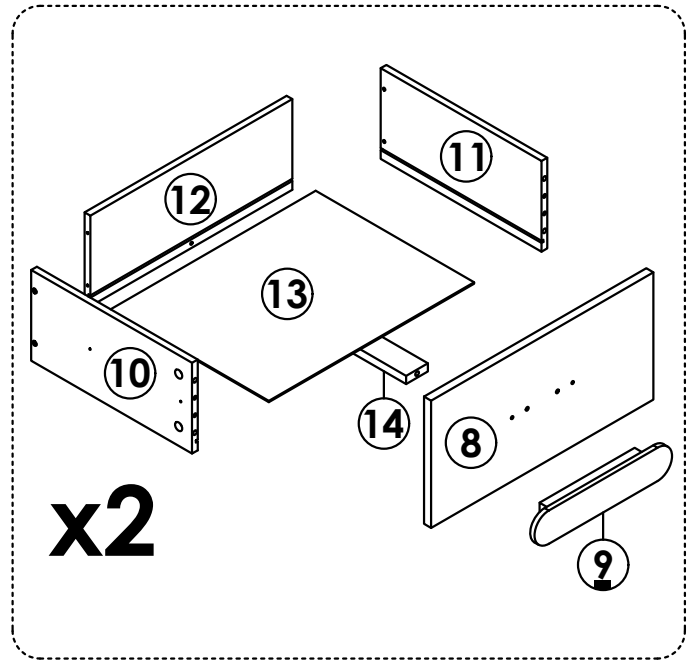

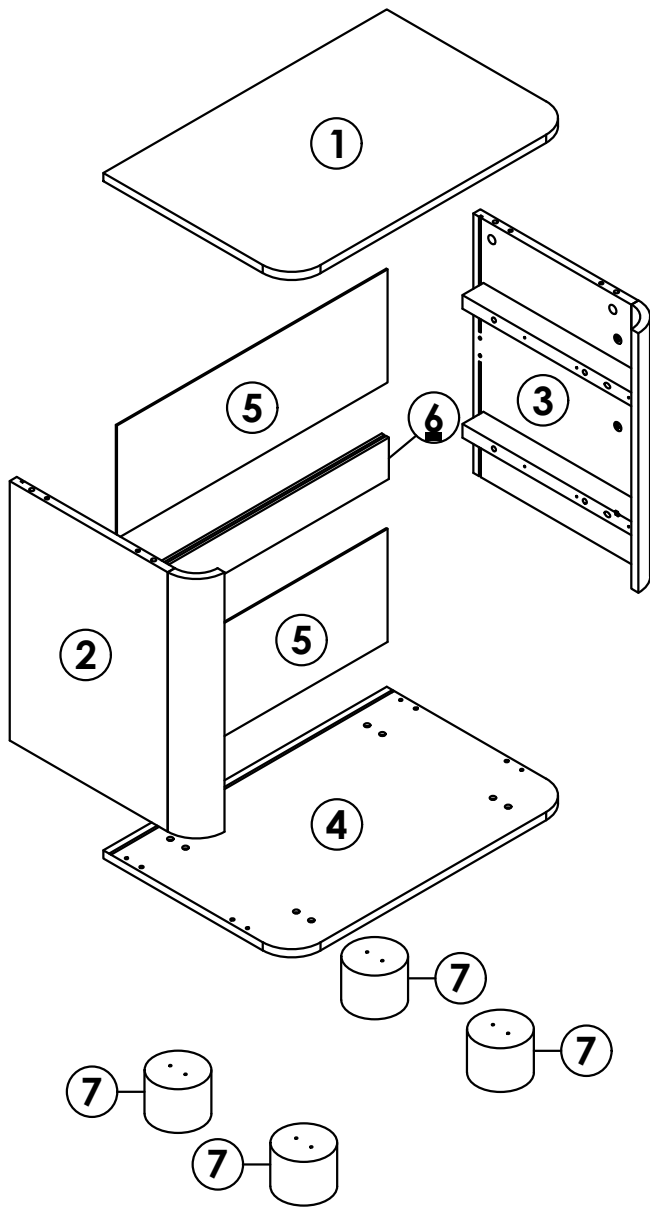



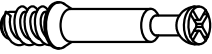

ASSEMBLY INSTRUCTION

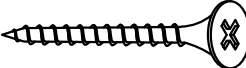
If there are any questions during the assembly process.

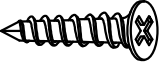
A video and description about the step you were stucked will help us to understand the problem quickly.

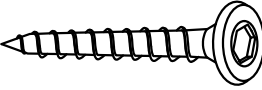

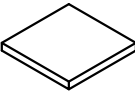
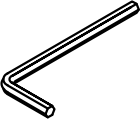
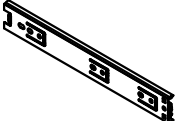

Ax18	Bx18	Cx18	Dx20
 6x35mm	 15x9mm	 4x40mm	 6x30mm
Ex8	Fx20	Gx8	Hx8
 3x14mm	 3x12mm	 5x45mm	
Ix4	Jx1	Kx4	Lx4
 45x45x5mm	 M4mm	 250mm	 247mm

1

1. Unfold the small part "L" of the large part "K", all the way to the end and in the direction shown.

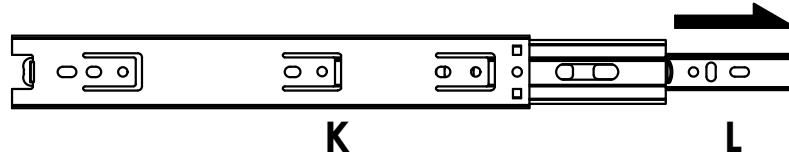

2. Press the lever of part "L", in the direction indicated, at the same time as you separate part "K" from part "L".

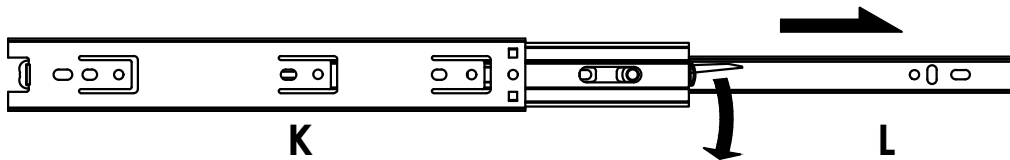

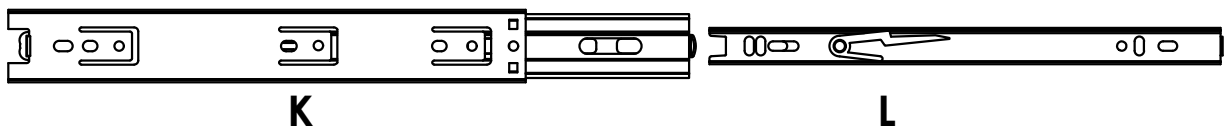

3. You should get two Sliders as shown below.

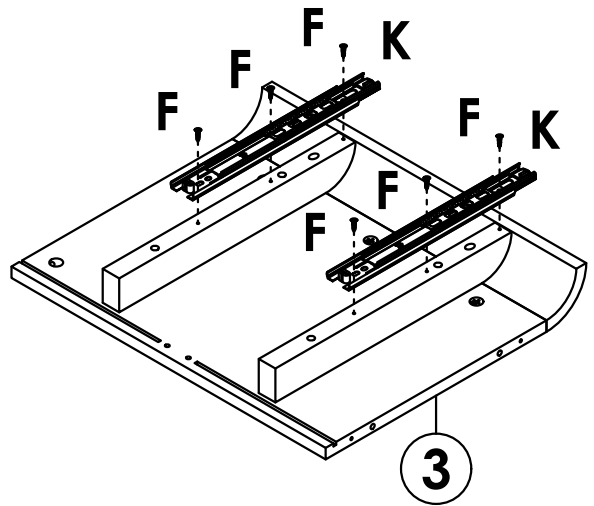
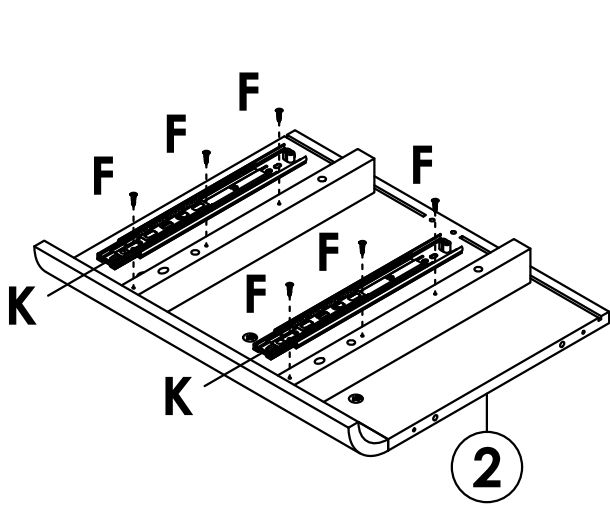
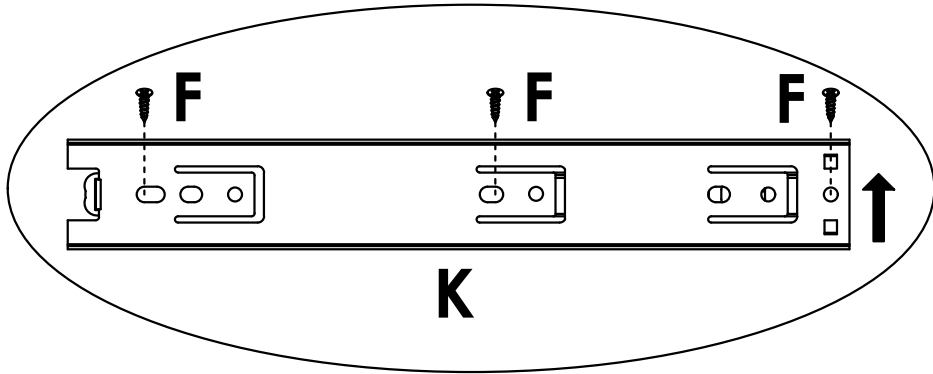

2



Fx12	Kx4
	

3

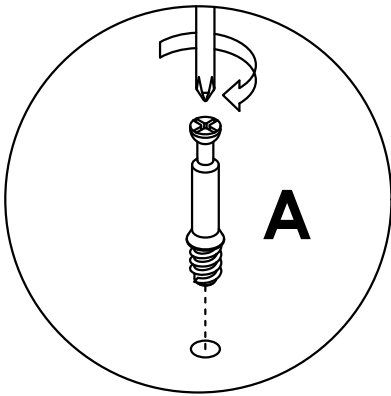
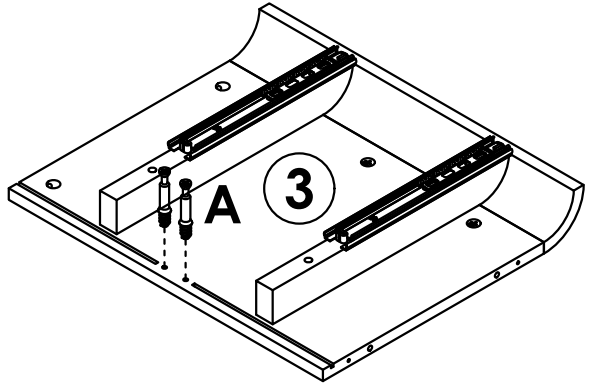
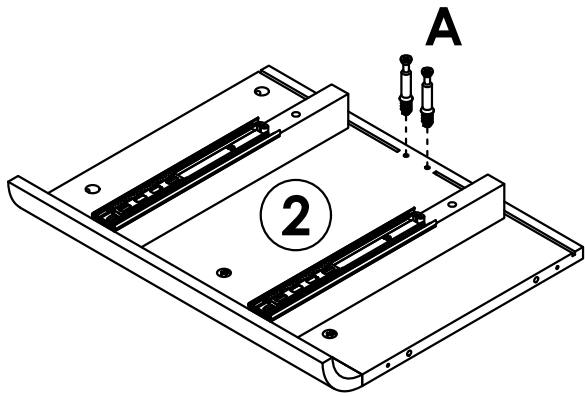

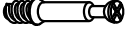
Ax4

4

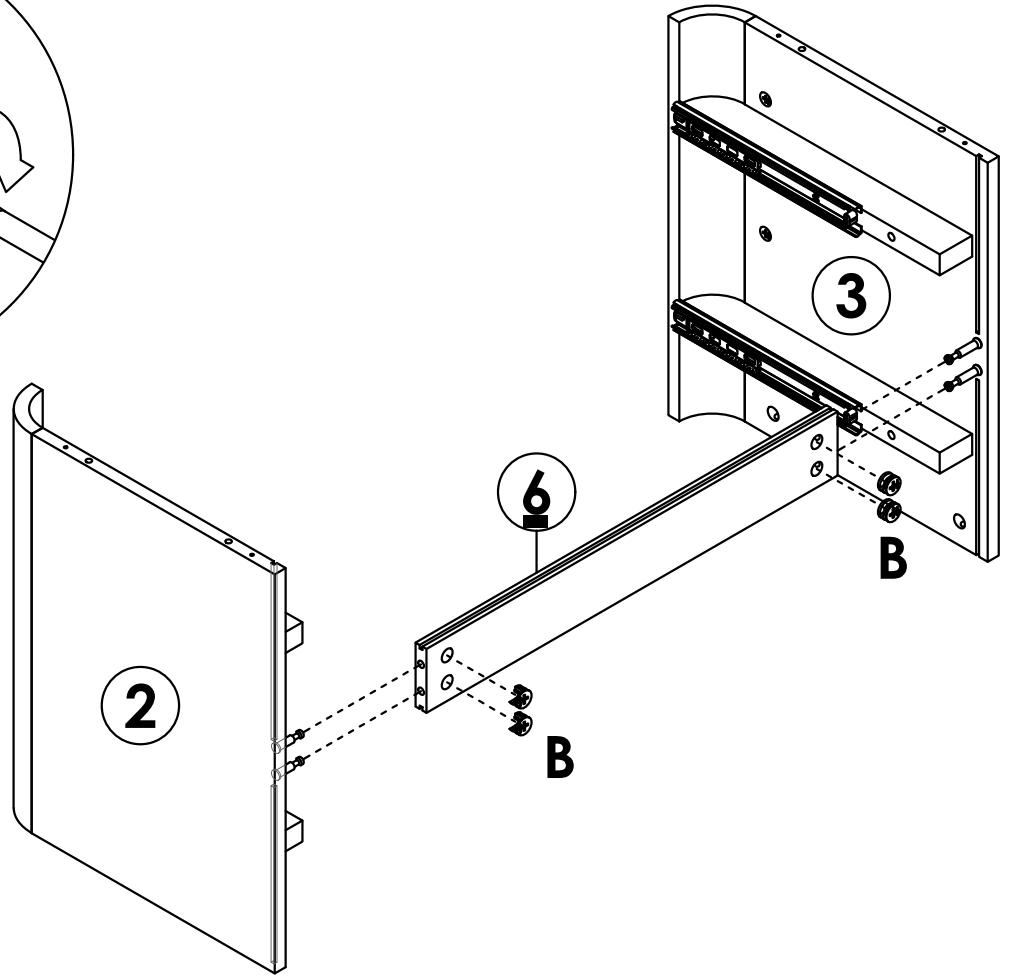
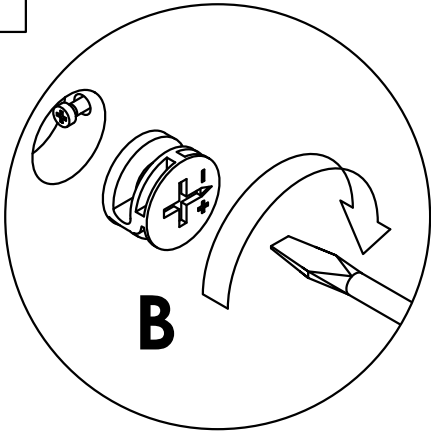

Bx4



5

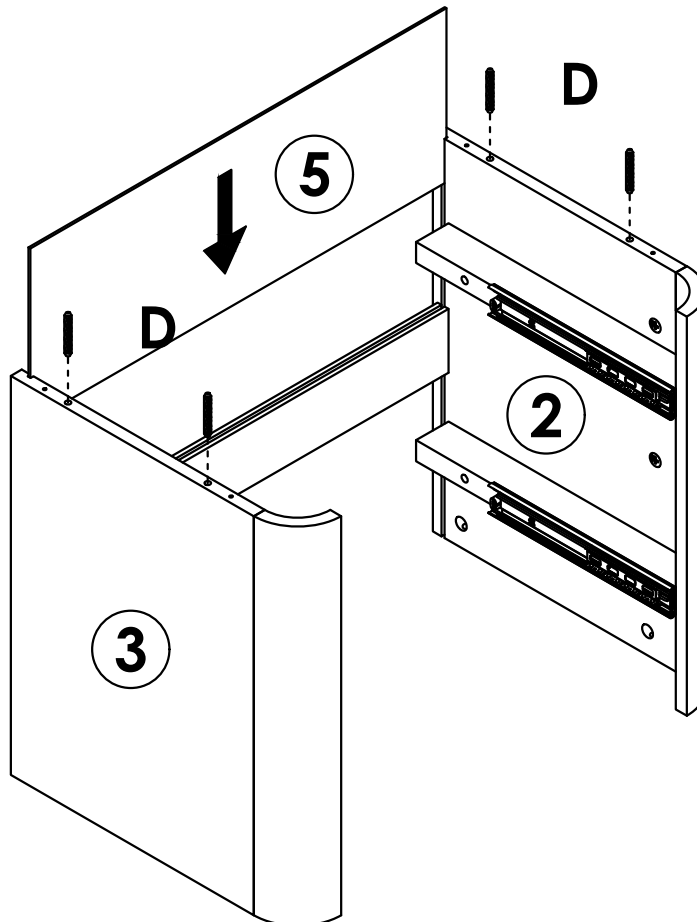

Dx4



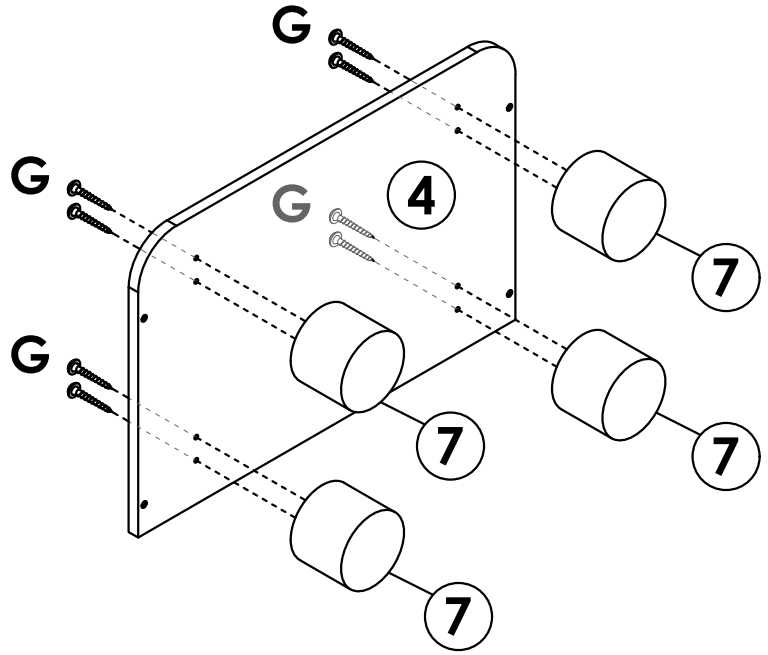
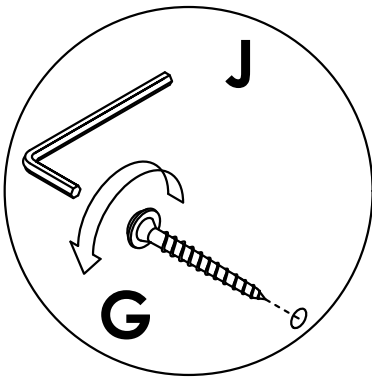

6

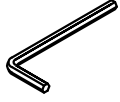

Gx8	Jx1
	

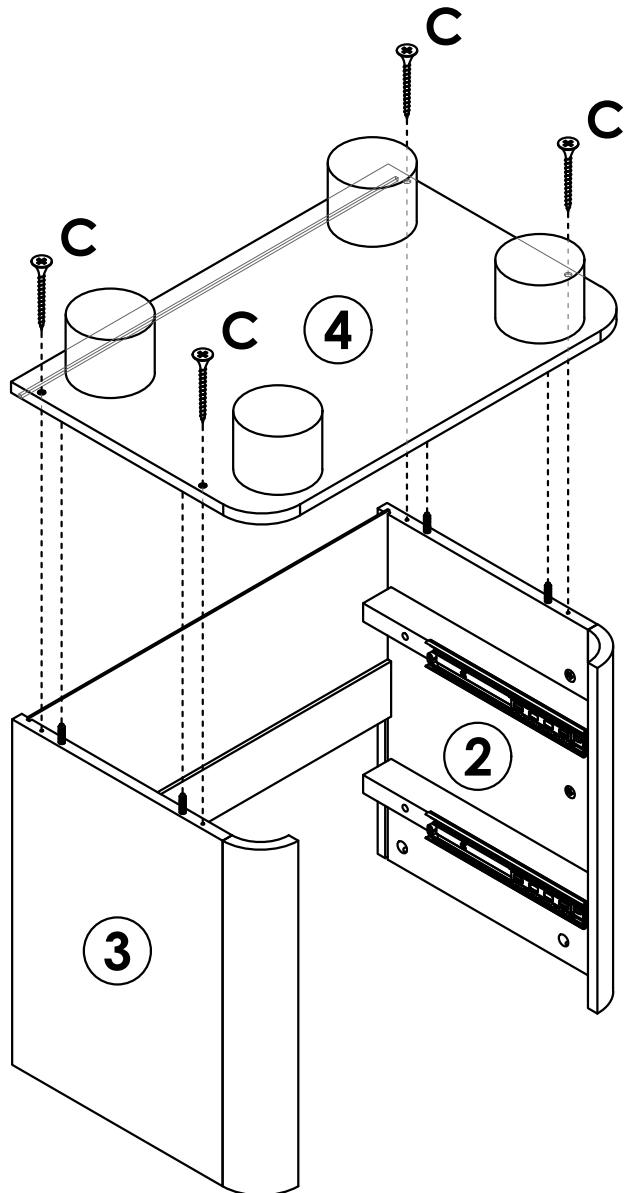
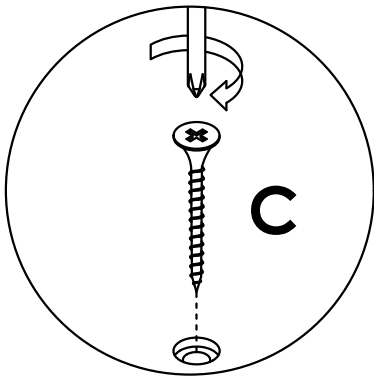
7



Cx4

8

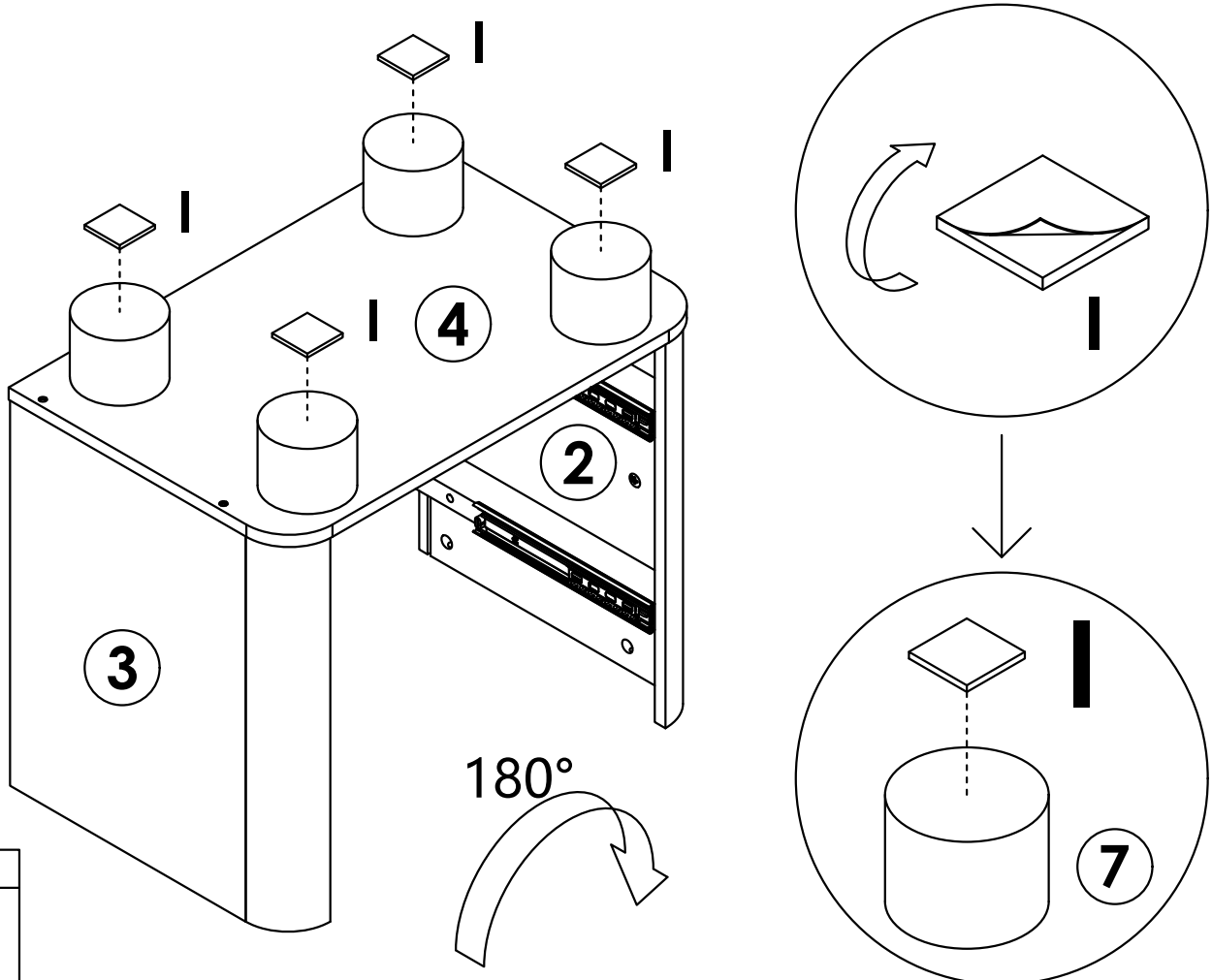

lx4

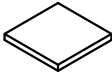

9

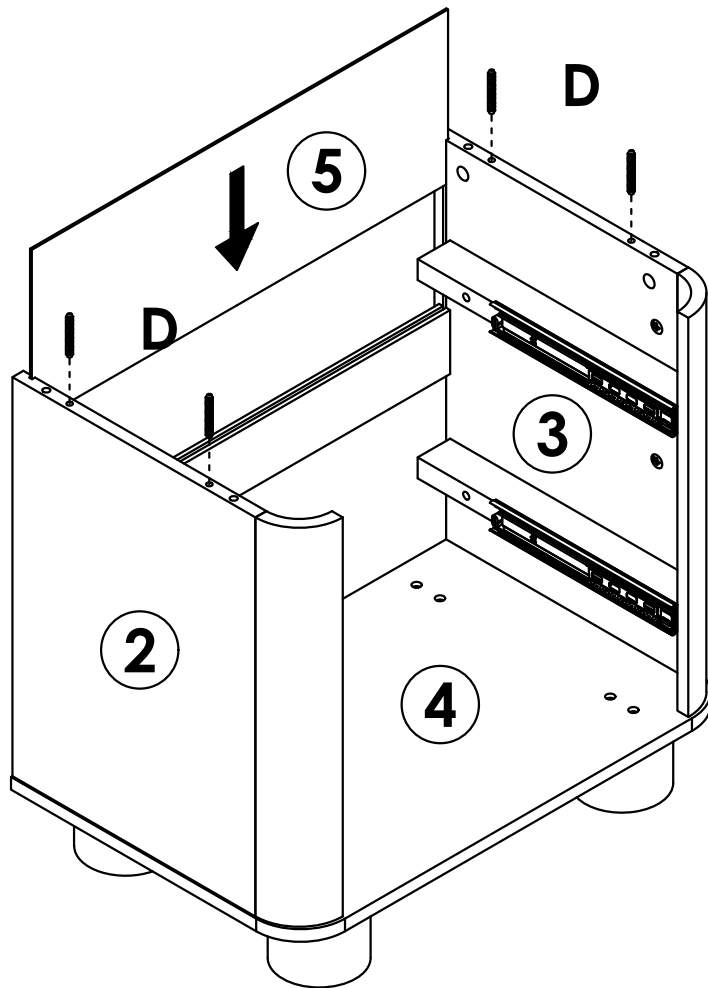

Dx4



10

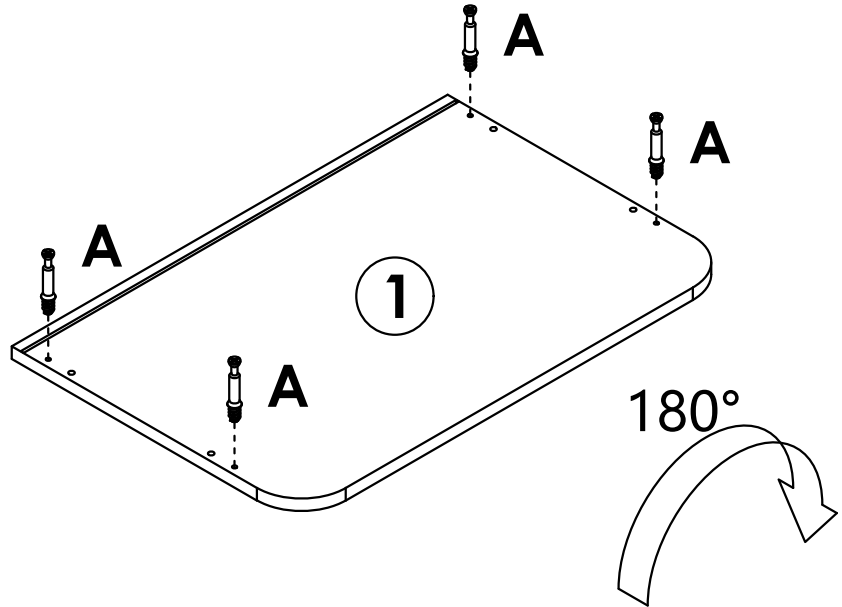
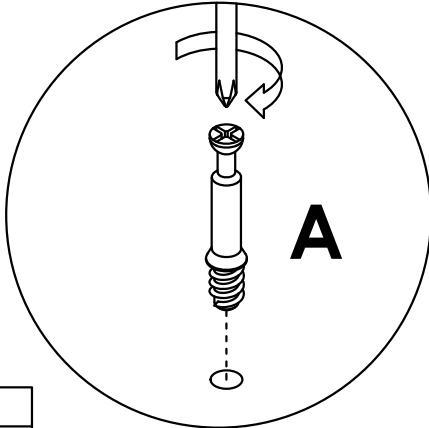

Ax4

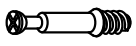

11

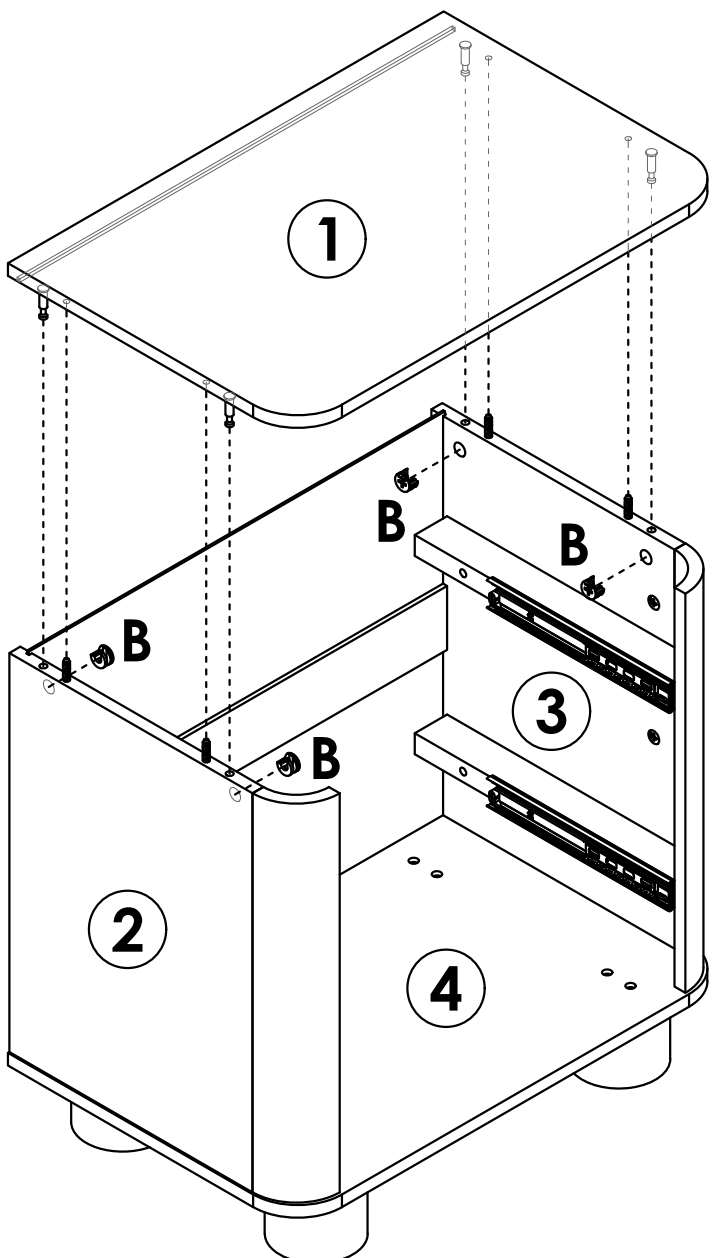
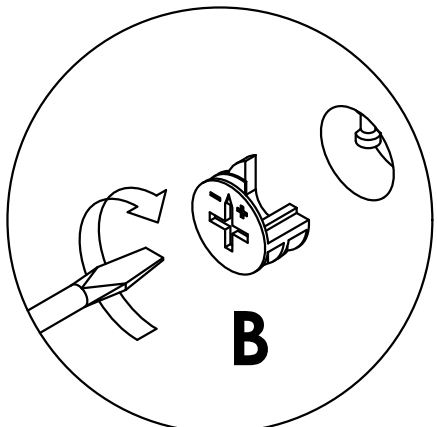

Bx4



12

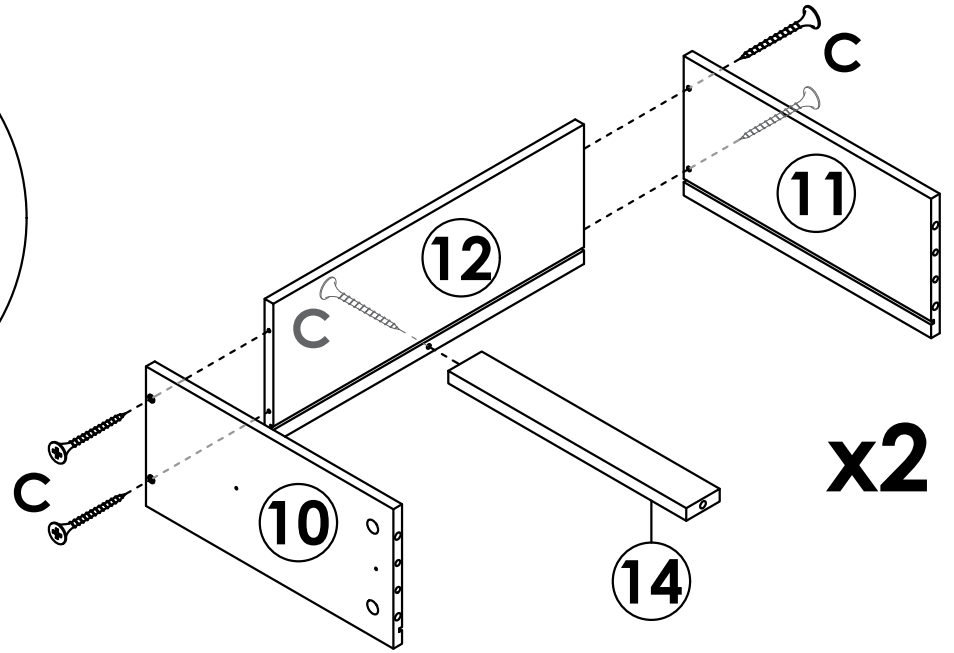
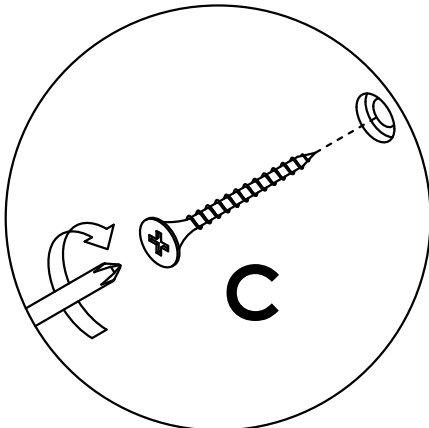

Cx10

13

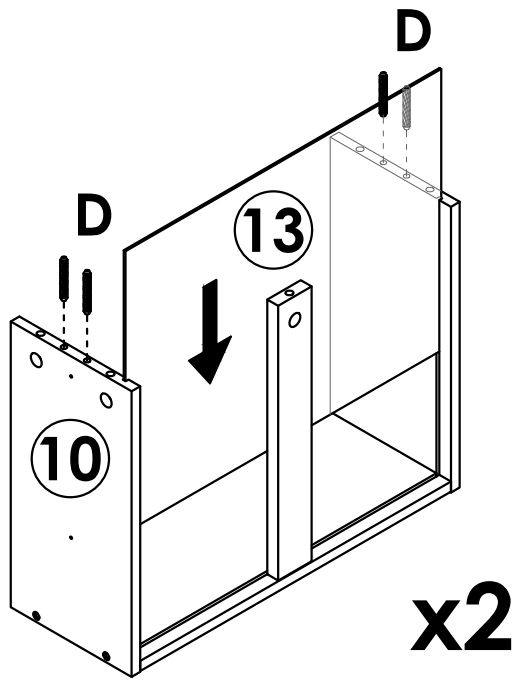

Dx8

14

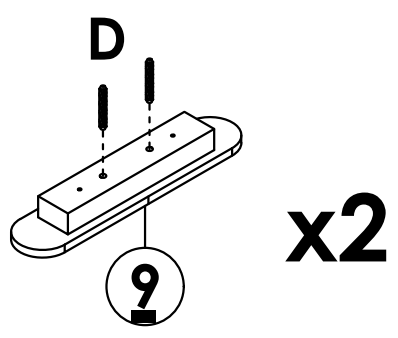

Dx4

15

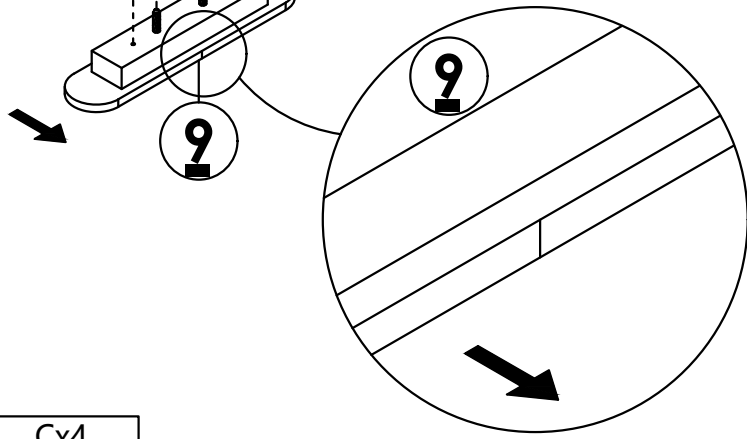
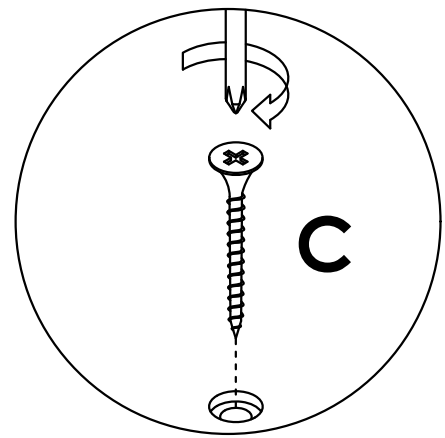
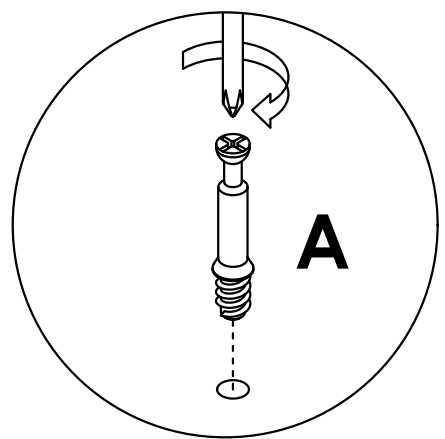
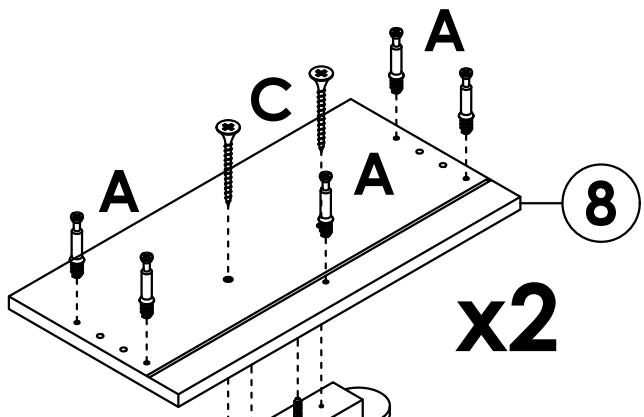

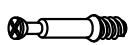
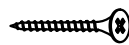

Ax10	Cx4
	

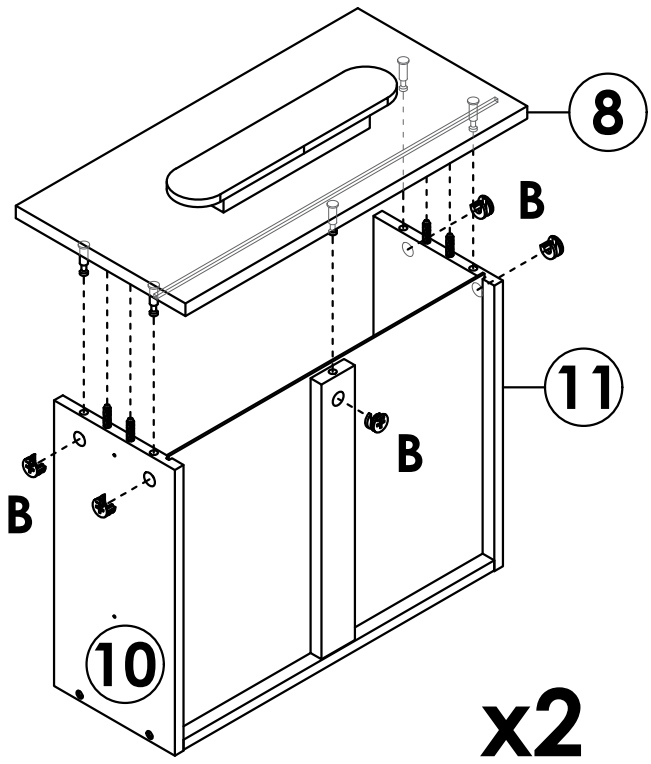
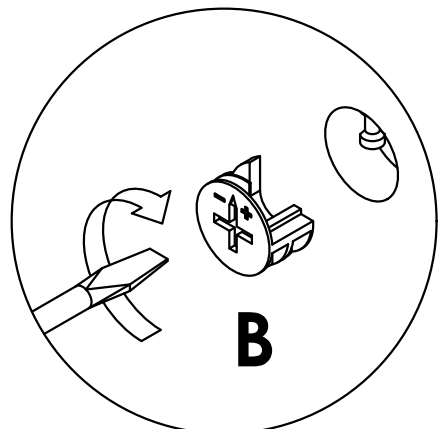
16



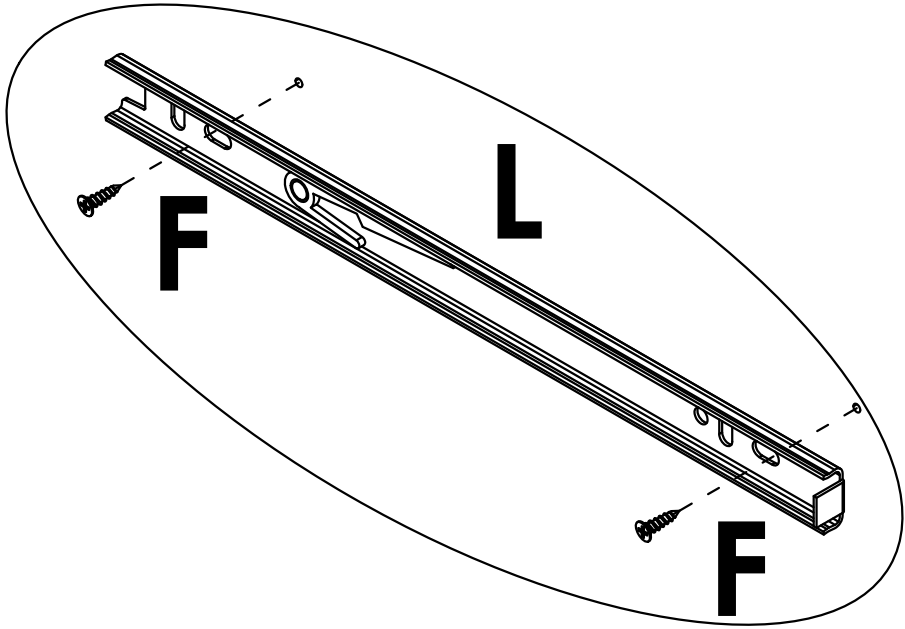
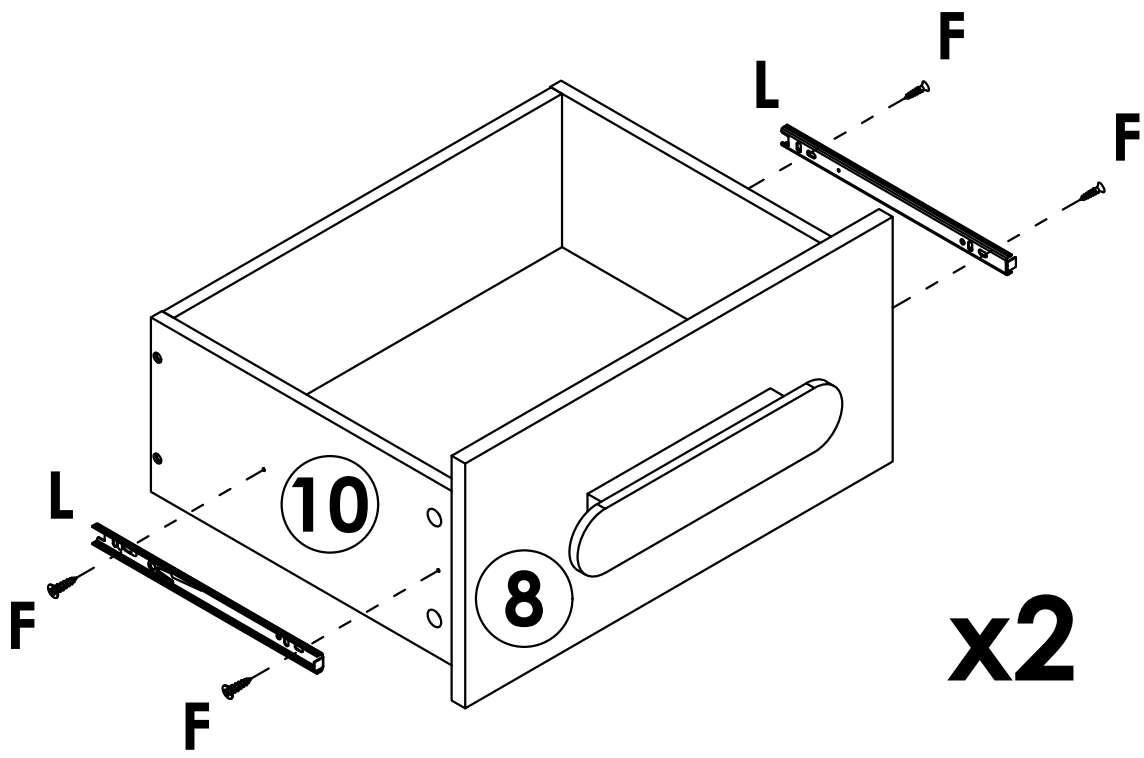

Bx10

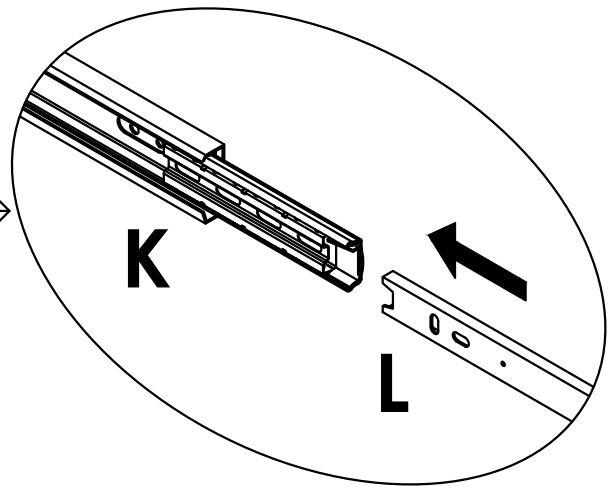
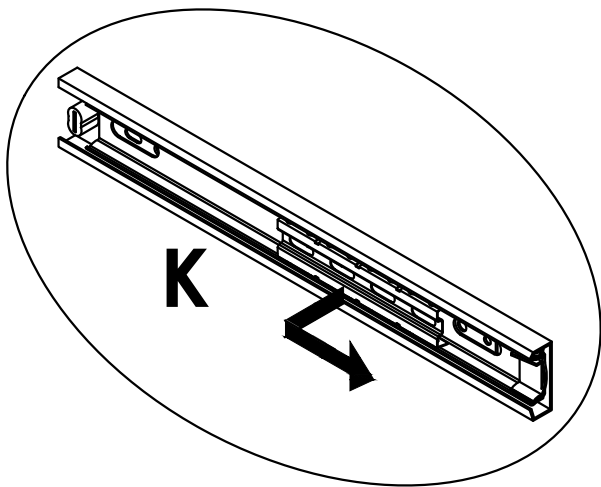
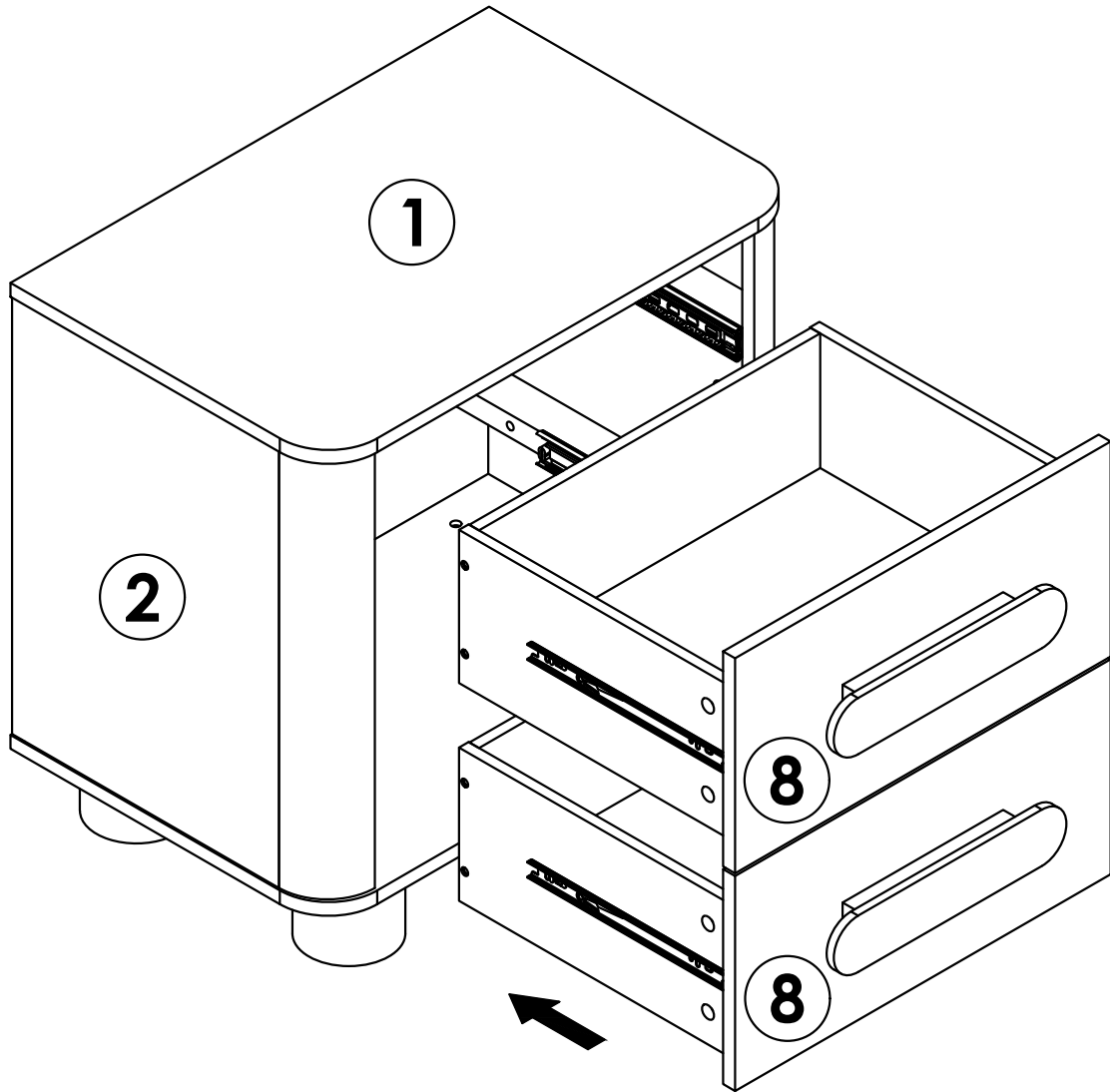

Fx8	Lx4
	

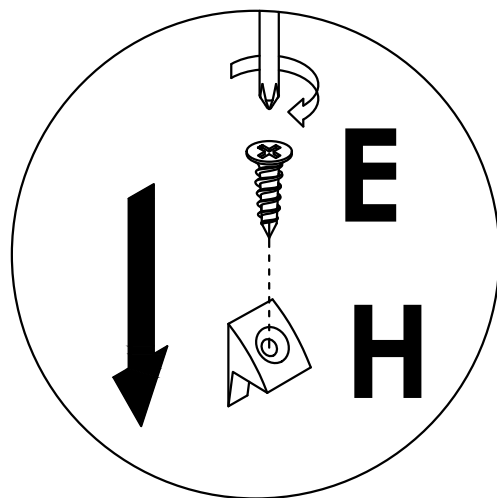
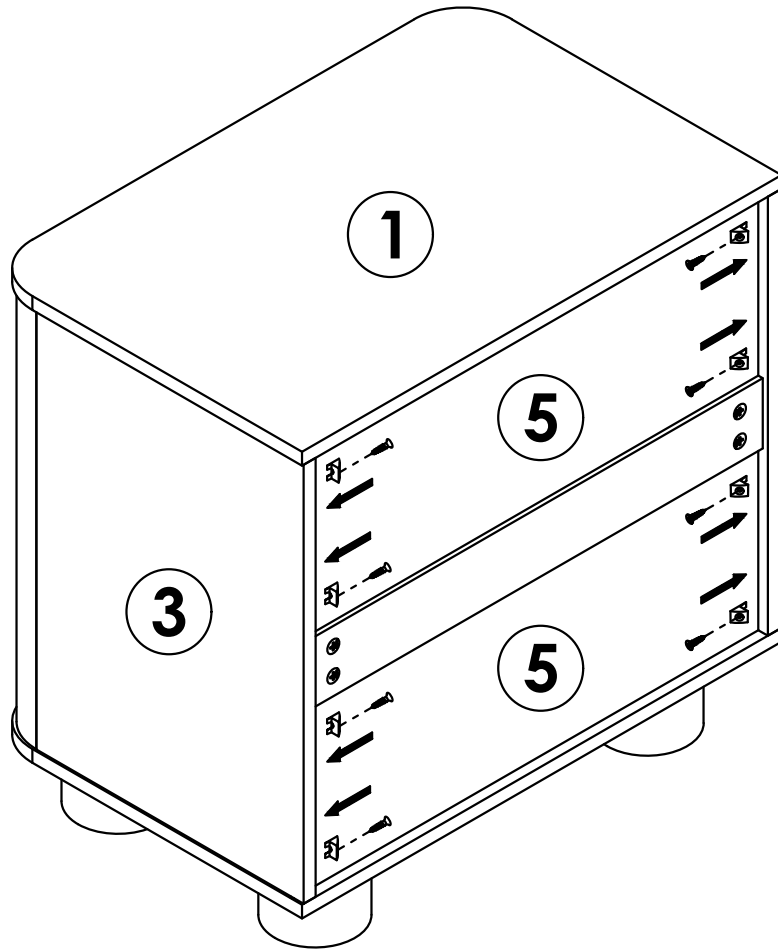



Ex8	Hx8
	

20

WALL

