

EN:

CAUTION:

- * Before using the chair, check to ensure that all bolts are fully tightened.
- * Tighten all bolts every 6 months or whenever needed.

To deodorize the chair, leave it in a shaded and well-ventilated outdoor area for 1-2 days.

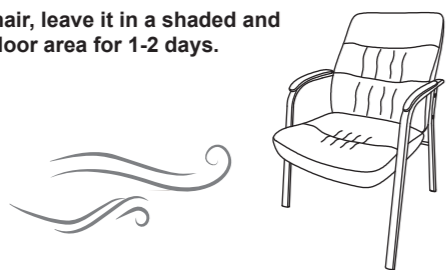

For long-term use, periodically retighten all bolts with the provided Allen Key. Note: Do not use an electric screwdriver, as it may damage the chair. Always tighten the bolts manually.

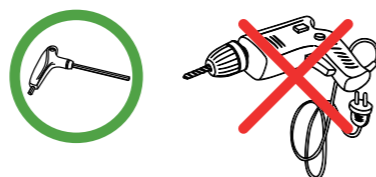

ES:

PRECAUCIÓN:

- * Antes de usar la silla, compruebe que todos los tornillos estén completamente apretados.
- * Apriete todos los tornillos cada 6 meses o cuando sea necesario.

Para desodorizar la silla, déjela al aire libre, en un lugar sombreado y bien ventilado, durante 1-2 días.



Para un uso prolongado, apriete periódicamente todos los tornillos con la llave Allen suministrada. Nota: No utilice un destornillador eléctrico, ya que podría dañar la silla. Apriete siempre los tornillos manualmente.

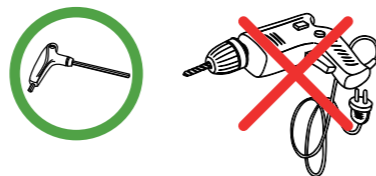

FR:

ATTENTION :

- * Avant d'utiliser la chaise, vérifiez que tous les boulons sont bien serrés.
- * Serrez tous les boulons tous les 6 mois ou chaque fois que nécessaire.

Pour désodoriser la chaise, laissez-la à l'extérieur dans un endroit frais et bien ventilé pendant 1-2 jours.



Pour une utilisation à long terme, resserrez régulièrement tous les boulons en utilisant la clé Allen. Remarque : N'utilisez pas de tournevis électrique, car cela pourrait endommager la chaise. Serrez toujours les boulons manuellement.

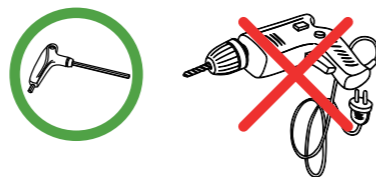

Safety Information / Información de seguridad / Informations Relatives à la Sécurité



**INSTRUCTION MANUAL
MANUAL DE INSTRUCCIONES
MANUEL D'INSTRUCTIONS**

FL-HKY5101

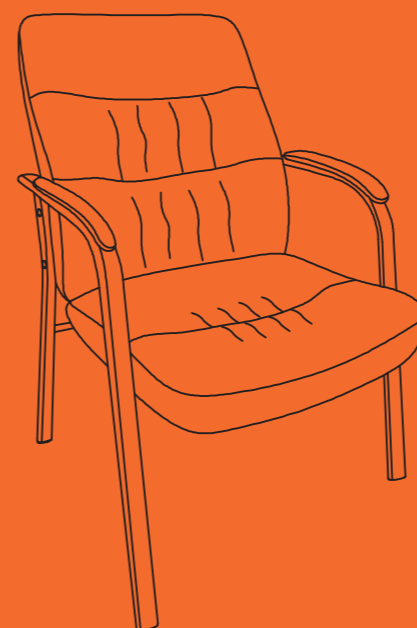

- ✉ HJ-Customer-Service@outlook.com
☎ (909)637-7665 | (909)637-7593
EST 9:00AM--17:00PM
- ✉ HJ-Customer-Service@outlook.com
☎ (909)637-7665 | (909)637-7593
9:00-17:00 (EST)
- ✉ HJ-Customer-Service@outlook.com
☎ (909)637-7665 | (909)637-7593
9h00--17h00 HNE

A ×1



EN: Left / Izquierda / Gauche

B ×1



EN: Right / Derecha / Droit

C ×1



D ×1



E ×4

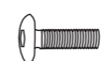

M6x35mm

F ×4

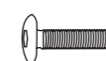

M6x40mm

G ×4



H ×1



EN: 70%: Partially tighten the bolts.

EN: 100%: Fully tighten the bolts.

ES: 70 %: Apriete parcialmente los tornillos.

ES: 100 %: Apriete completamente los tornillos.

FR: 70 %: Serrez partiellement les boulons.

FR: 100 % : Serrez complètement les boulons.

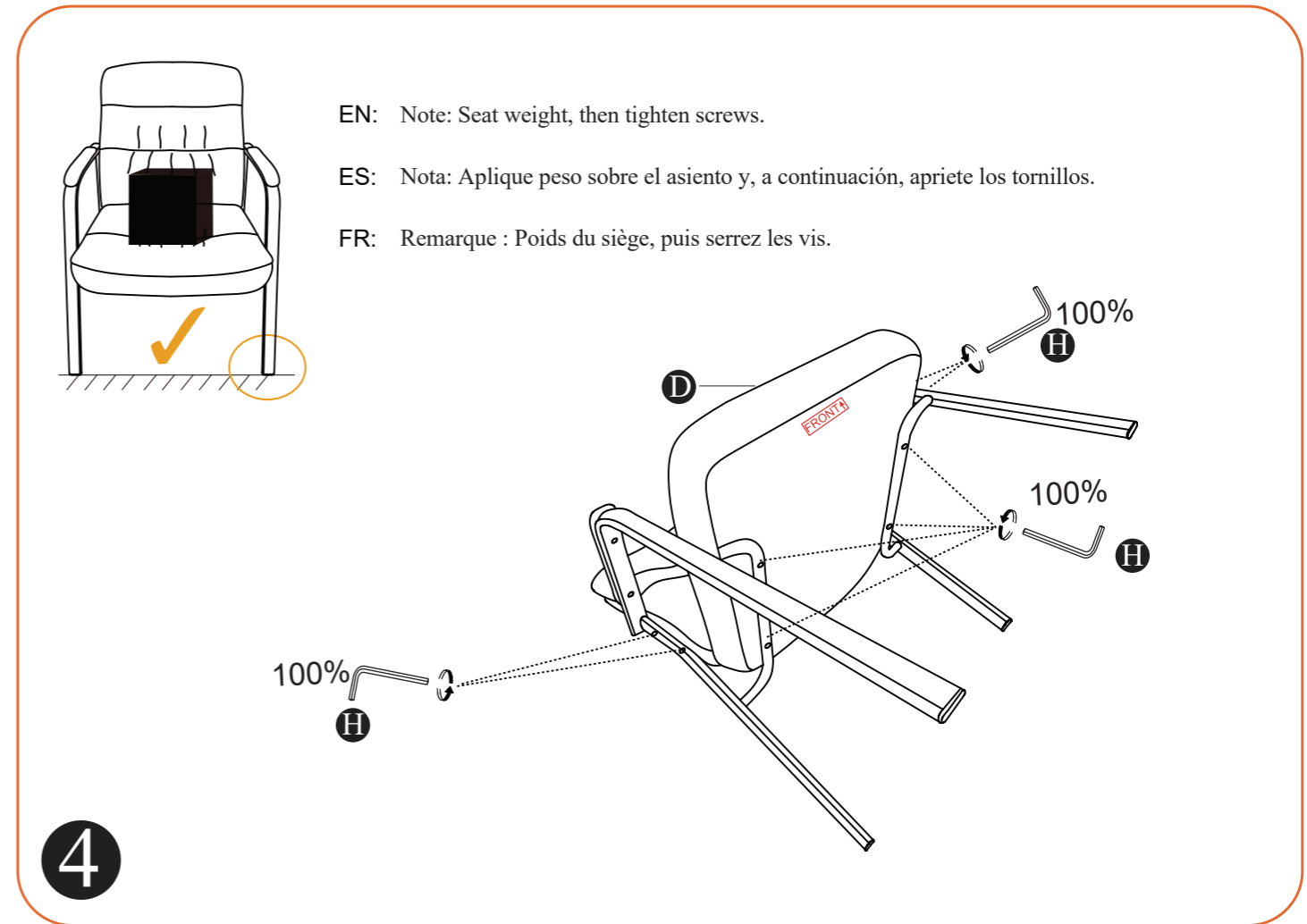
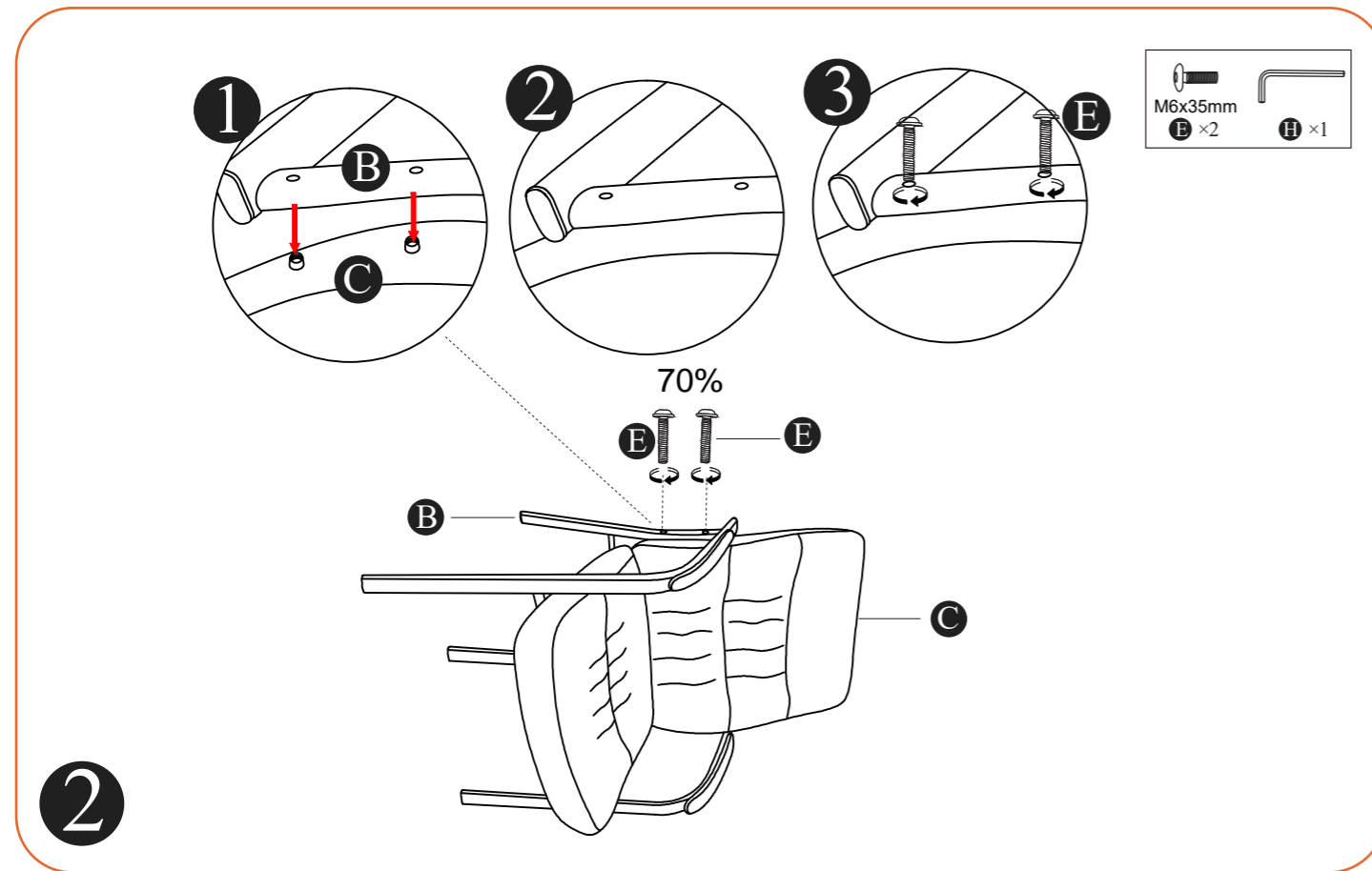
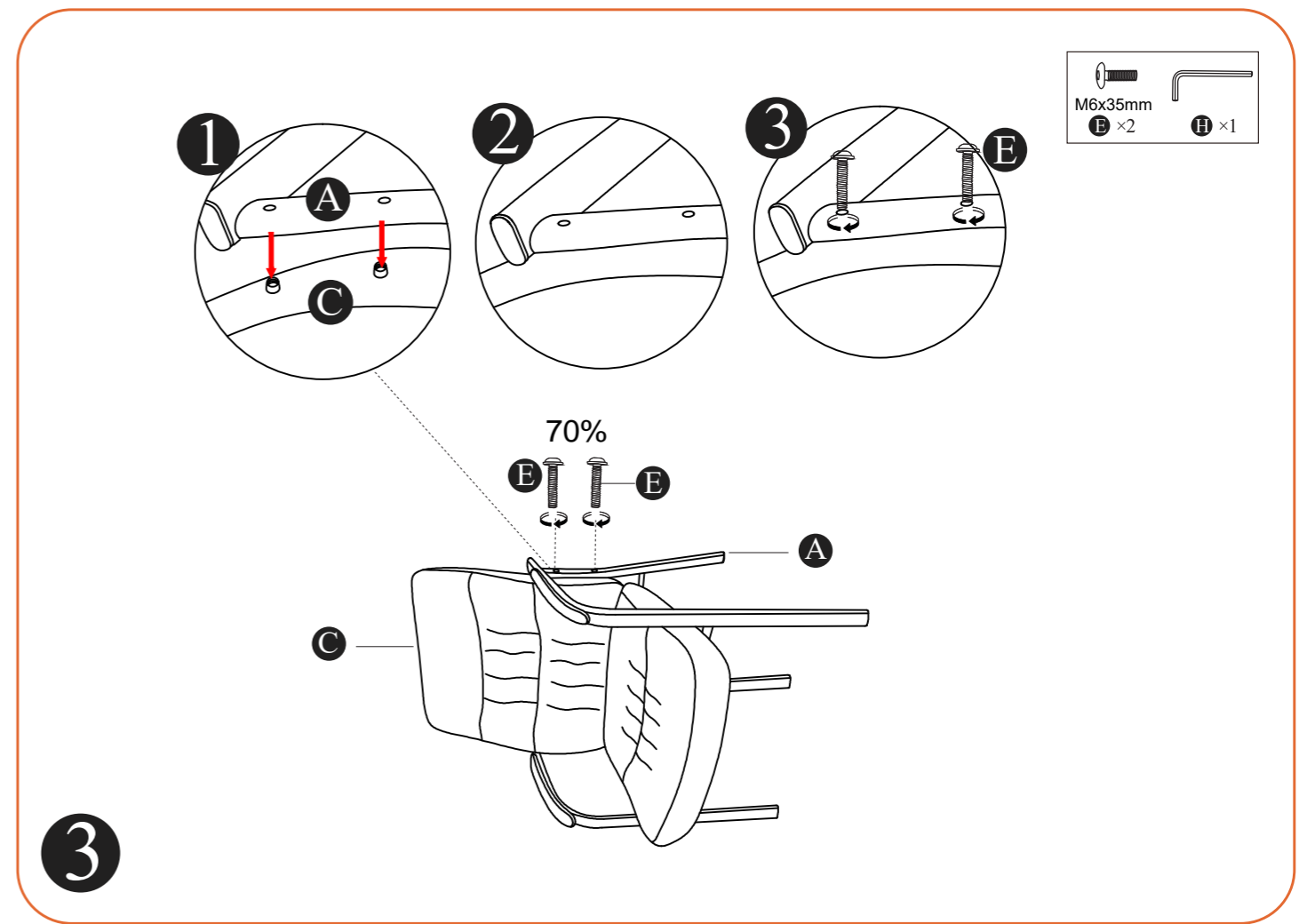
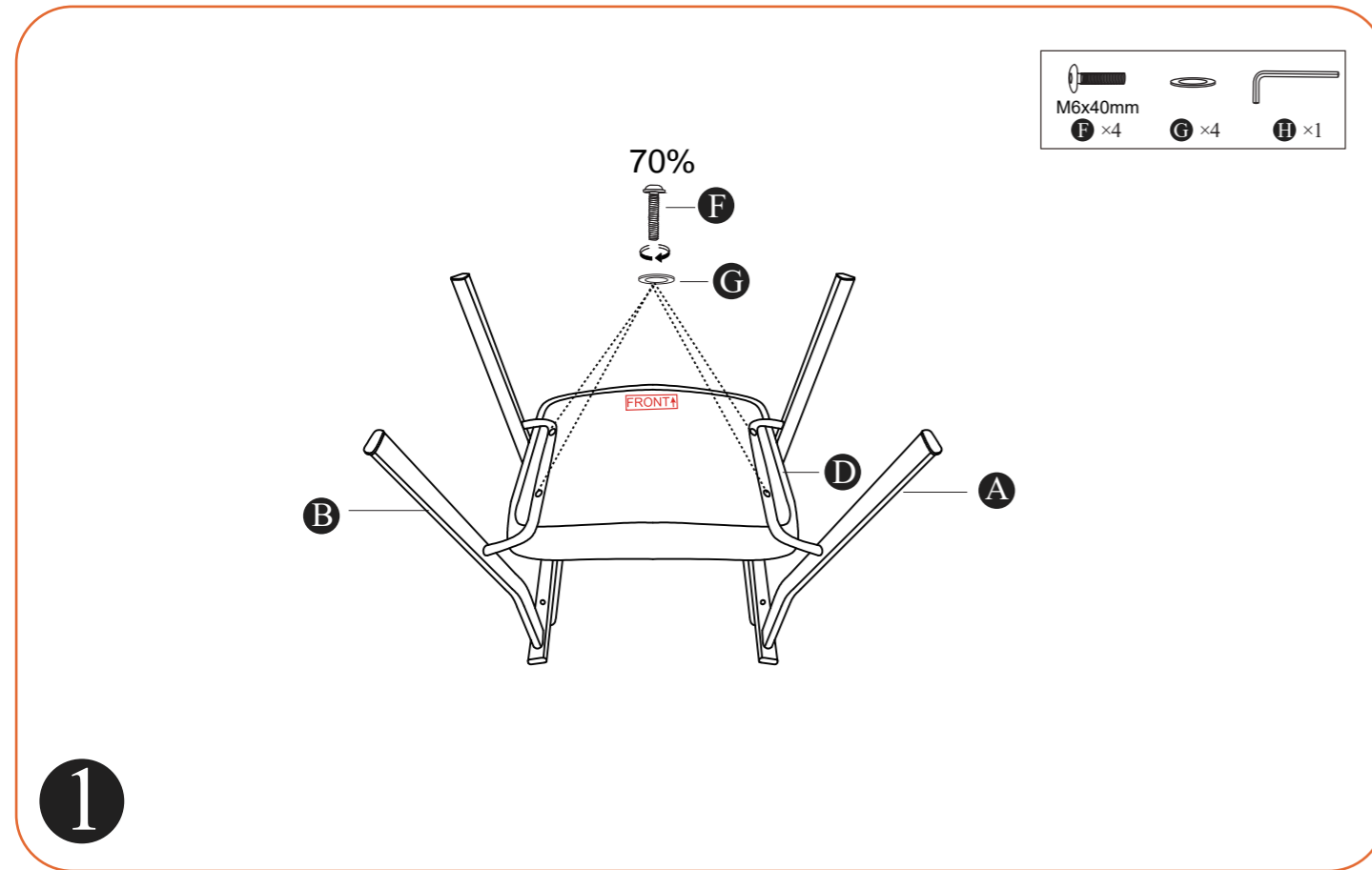

EN: Note: Seat weight, then tighten screws.

ES: Nota: Aplique peso sobre el asiento y, a continuación, apriete los tornillos.

FR: Remarque : Poids du siège, puis serrez les vis.