

DJYC2403 / 2403B

ASSEMBLY INTRODUCTION

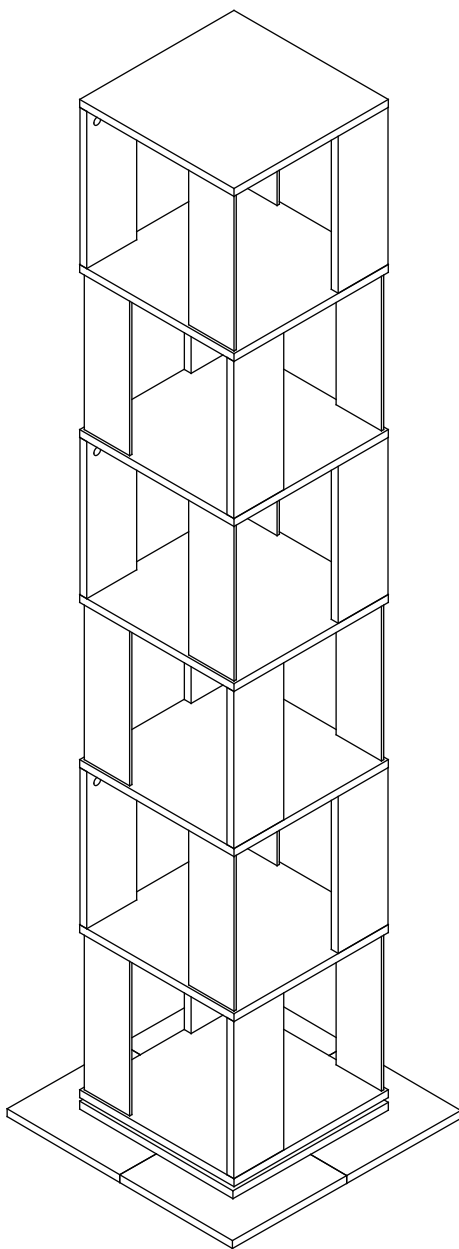

Plate

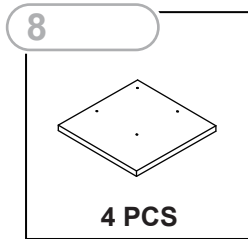
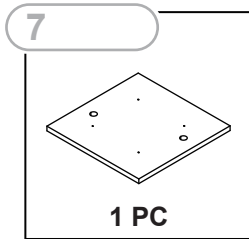
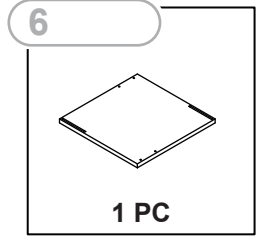
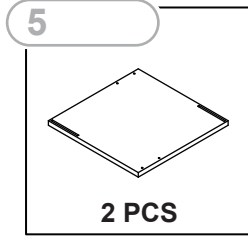
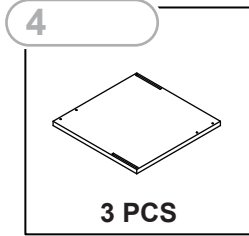
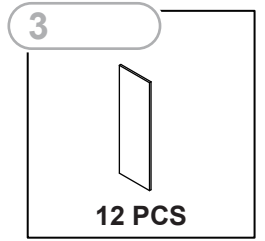
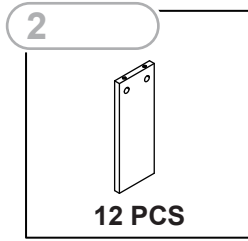
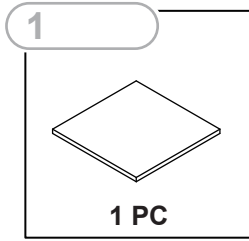
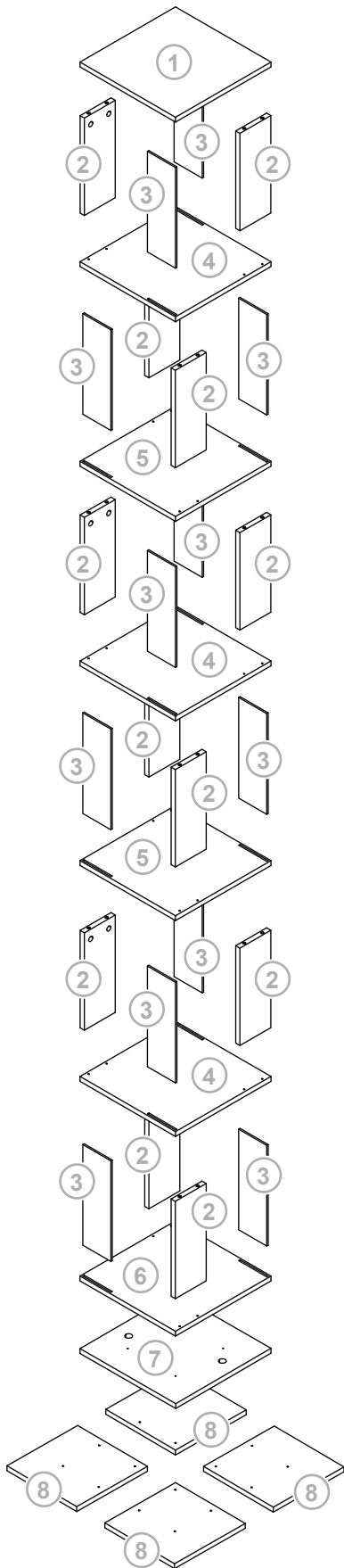

Fitting

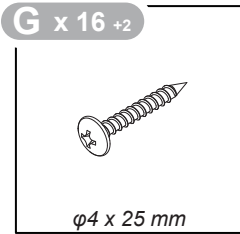
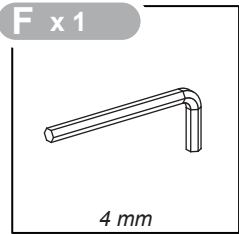
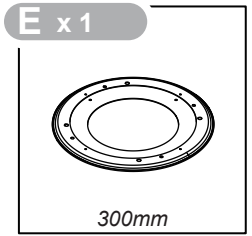
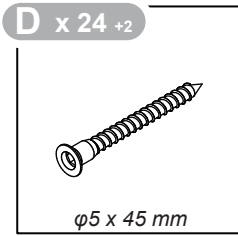
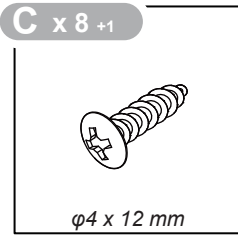
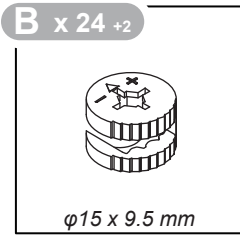
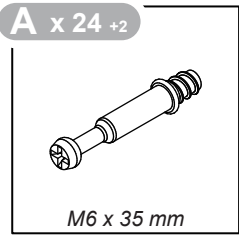

1

A x 24

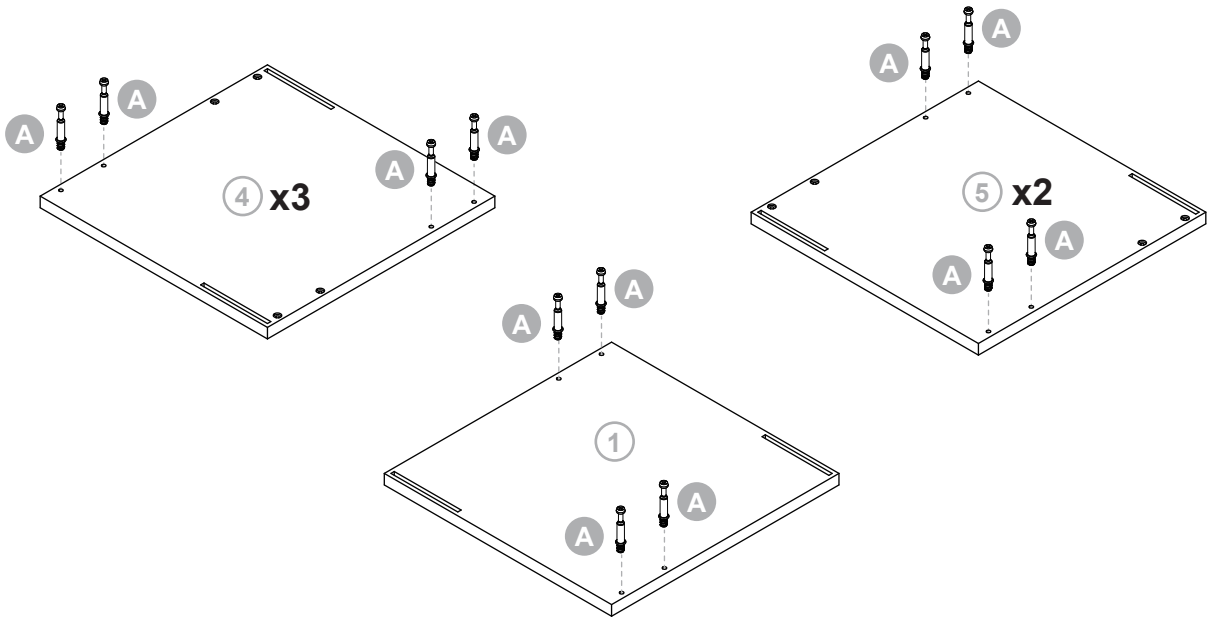
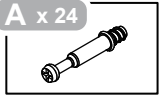

2

Remove the protective film of the acrylic sheet.

B x 4

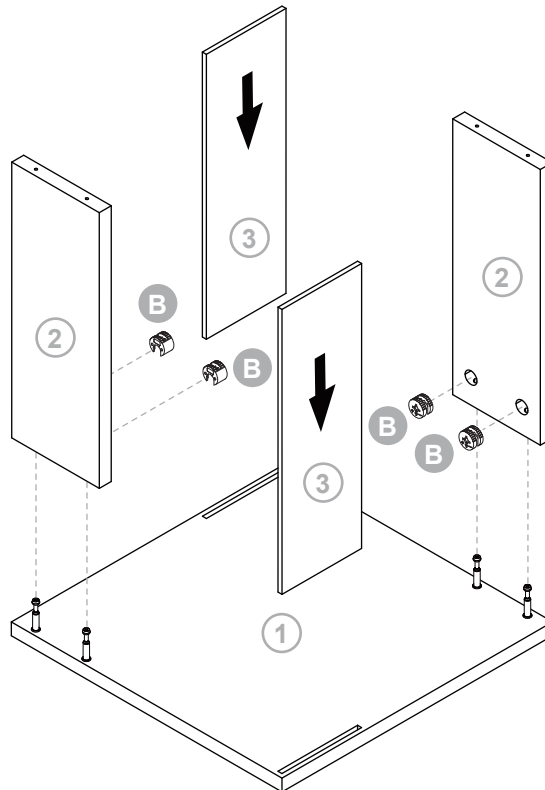

3

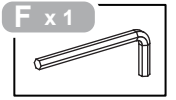
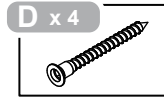
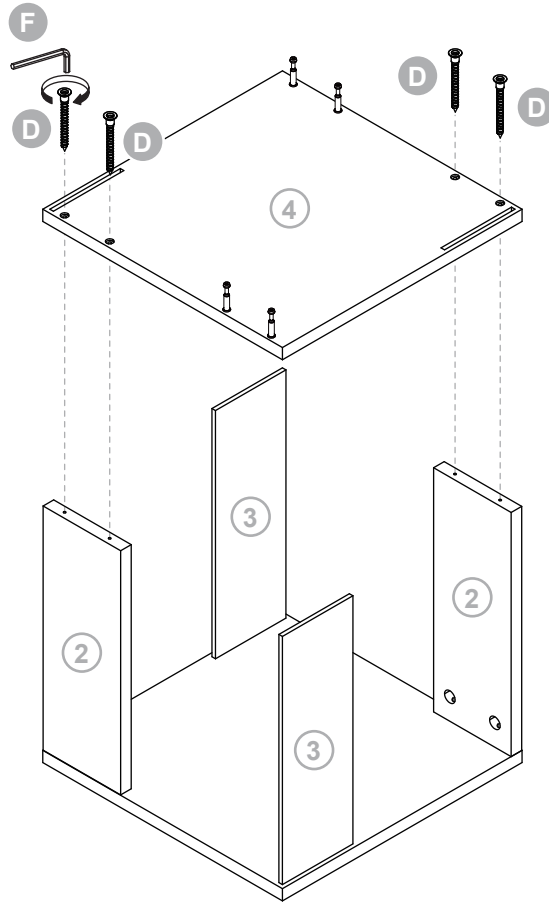

4

Remove the protective film of the acrylic sheet.

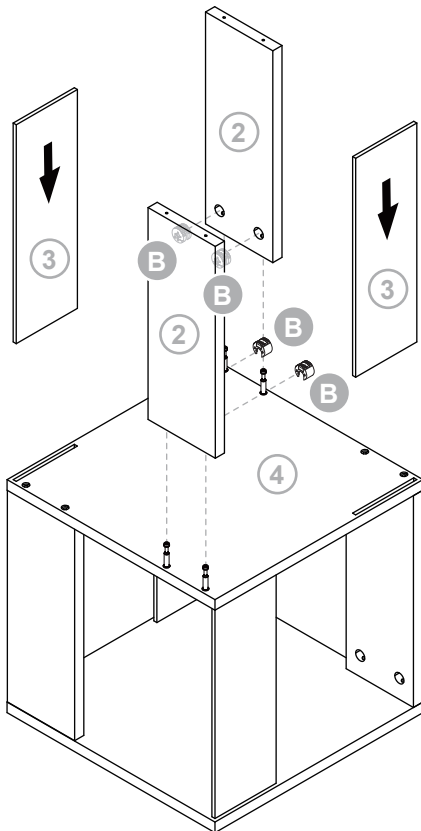
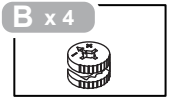

5

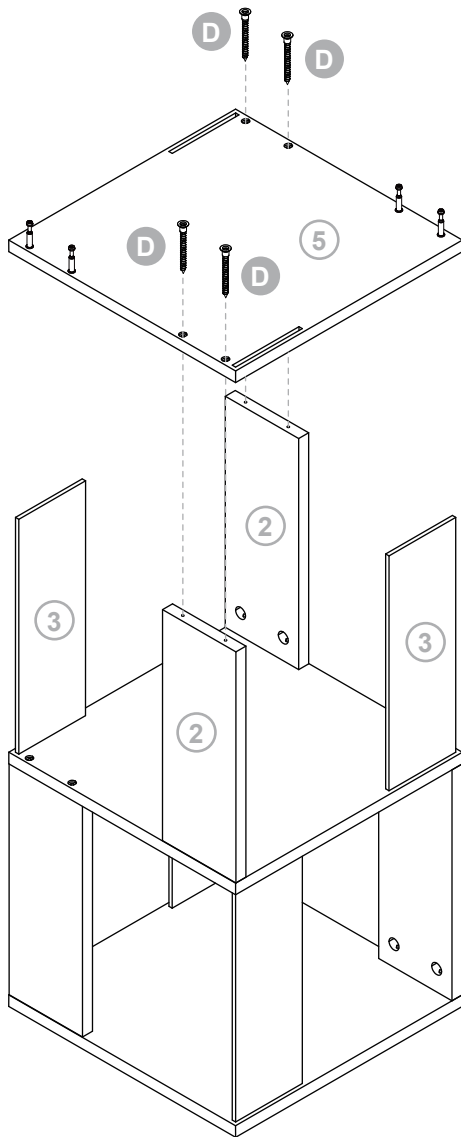
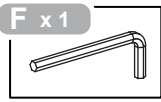
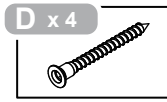

6

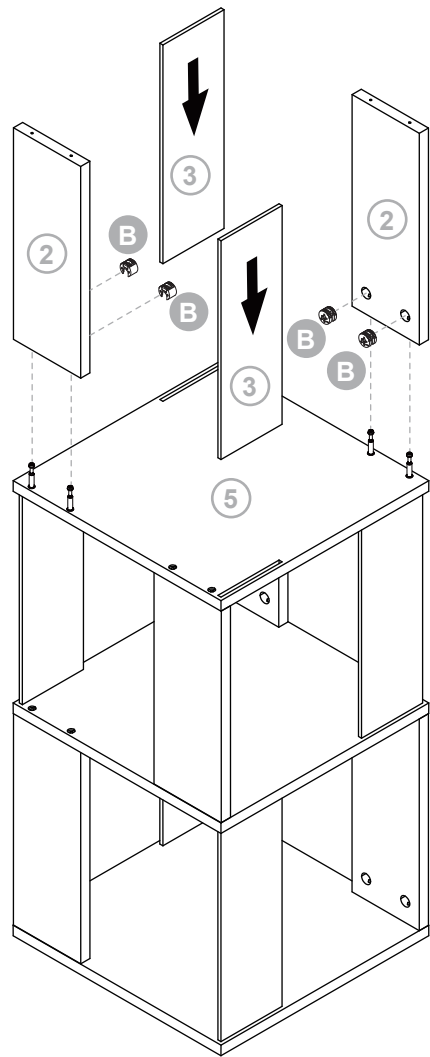
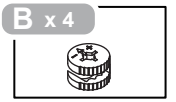

Remove the protective film of the acrylic sheet.

7

D x 4

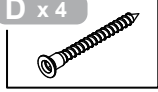

F x 1

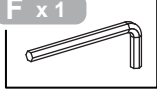

8

B x 4

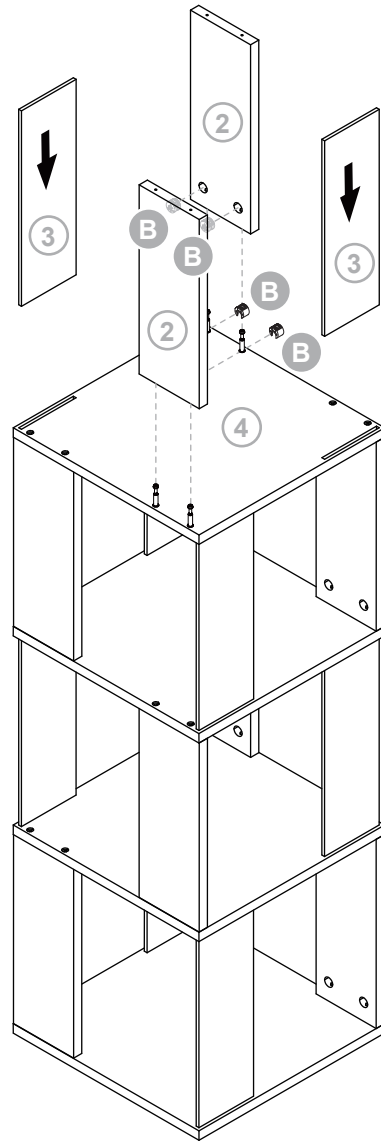
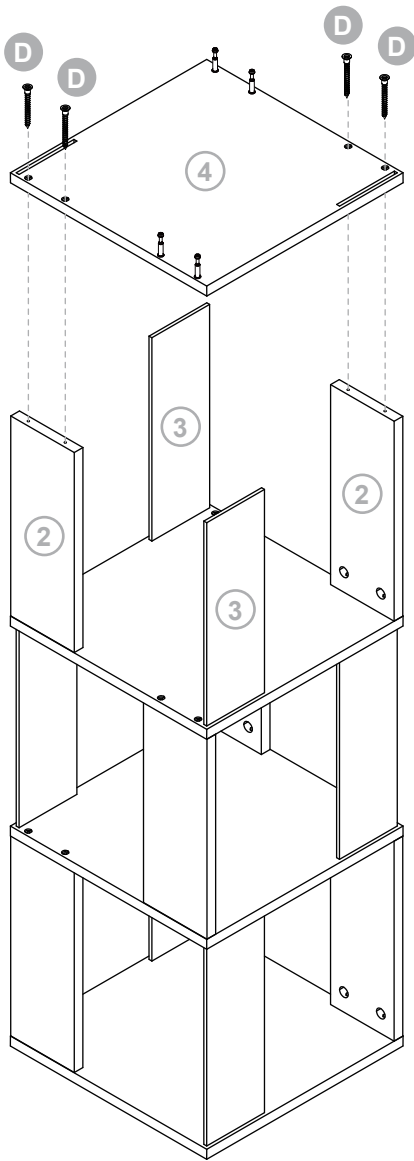

Remove the protective film of the acrylic sheet.

9

B x 4



10

D x 4

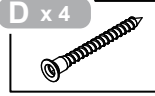

F x 1

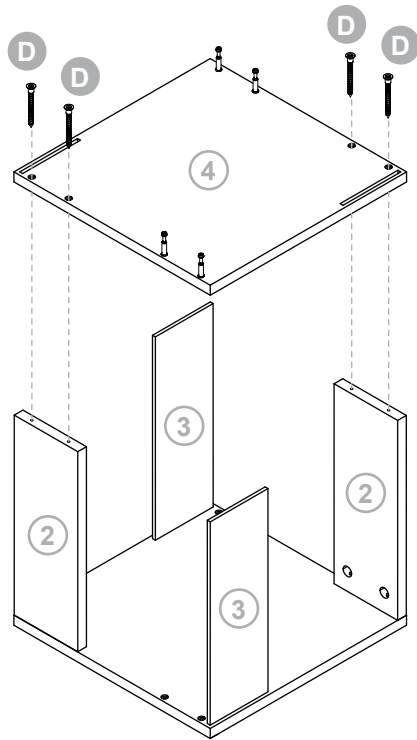
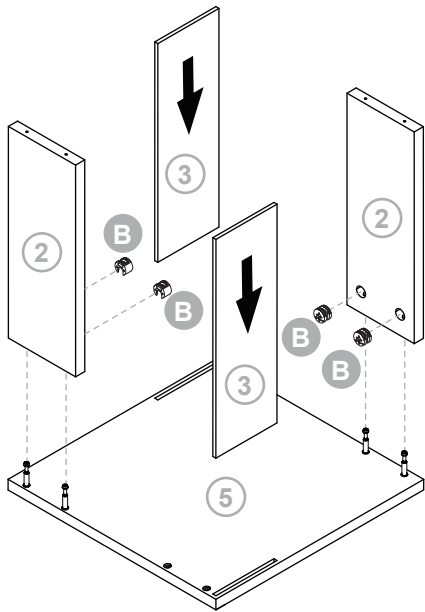
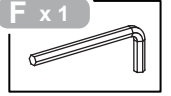

Remove the protective film of the acrylic sheet.

11

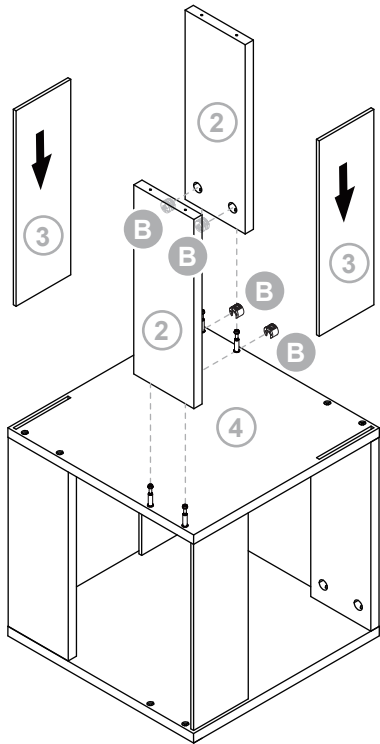
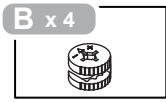

12

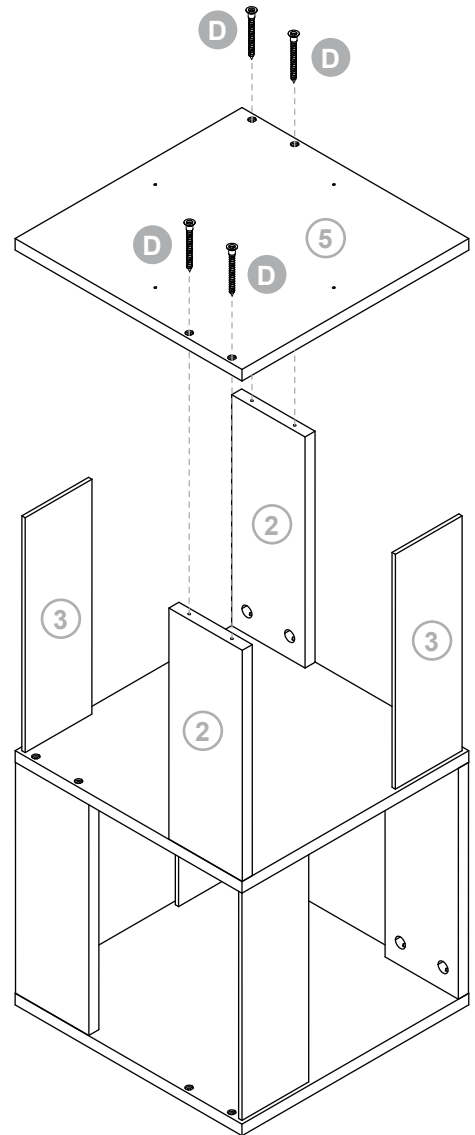
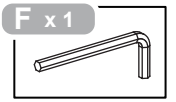
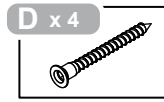

Remove the protective film of the acrylic sheet.

13

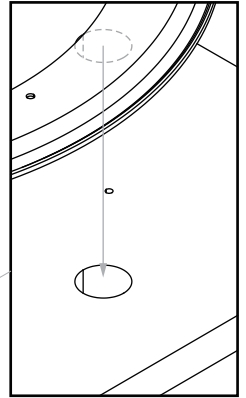
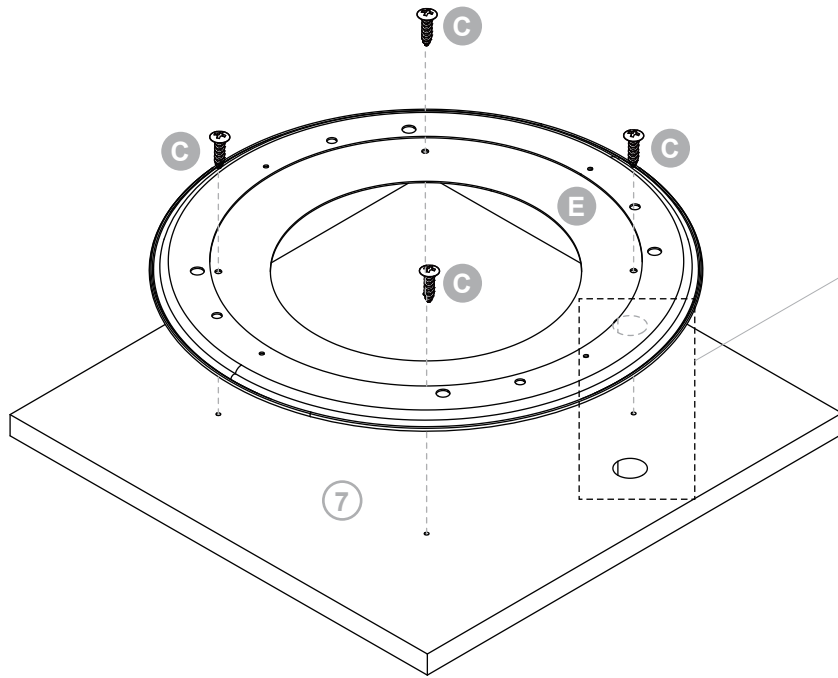
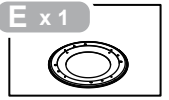
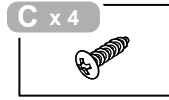

14

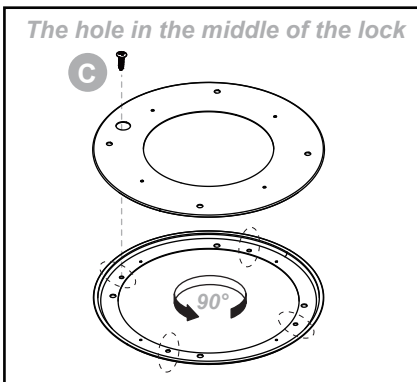
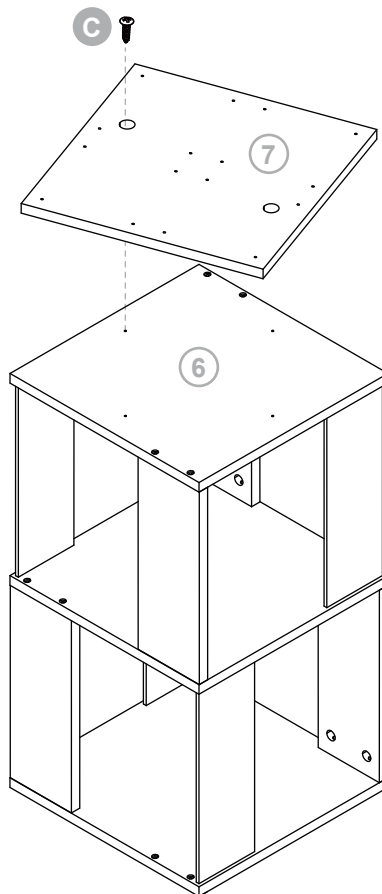
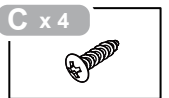

15

G x 16

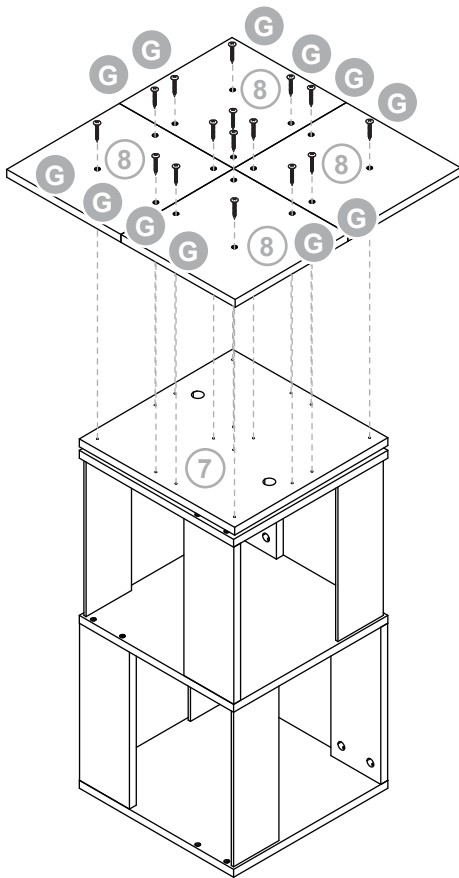
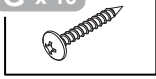

16

D x 4



F x 1

