









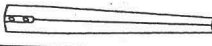

# ASSEMBLY INSTRUCTIONS

## TABLE

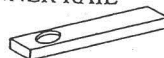
- \* PLACE ALL WOODEN PARTS ON A CLEAN AND SMOOTH SURFACE SUCH AS A RUG OR CARPET TO AVOID THE PARTS FROM BEING SCRATCHED.
- \* BEFORE YOU BEGIN, KINDLY FOLLOW THE ASSEMBLY INSTRUCTIONS STEP BY STEP.
- \* DO NOT TIGHTEN ALL SCREWS UNTIL THE PRODUCT IS FULLY SET-UP.

PARTS LIST			HARDWARE LIST		
NO	DESCRIPTION	QTY	NO	DESCRIPTION	QTY
1	TABLE TOP 	1PC	A	JCBC BOLT M6 X 60MM 	8PCS
2	LEAF TOP 	1PC	B	FLAT WASHER 	8PCS
3	TABLE LEG 	4PCS	C	SPRING WASHER 	8PCS
4	RUNNER RAIL 	2PCS	D	M4 ALLEN KEY 	1PC
			E	M3.5 X 16mm CHIPBOARD SCREW 	16PCS
			F	HINGE 	3PCS
			G	PLATE STOPPER 	2PCS

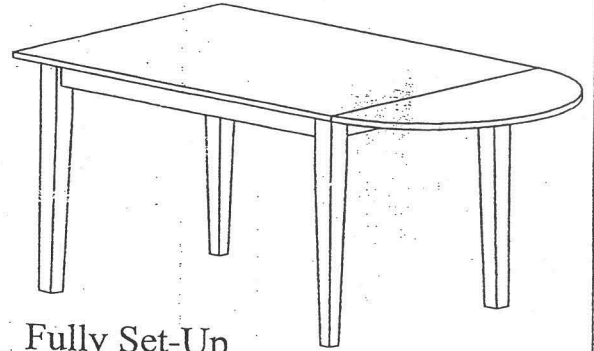

Fully Set-Up

### STEP 1

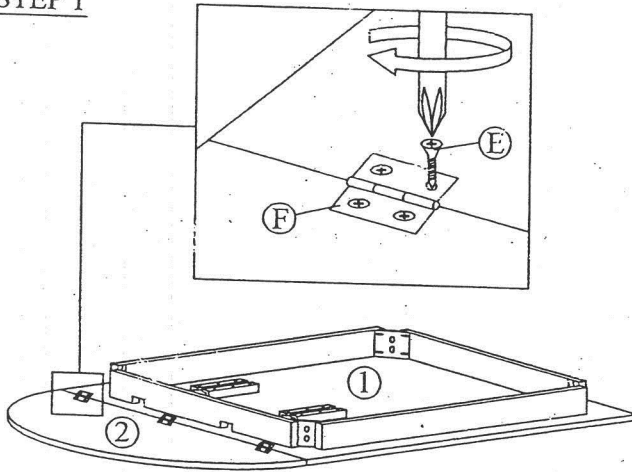

### STEP 2

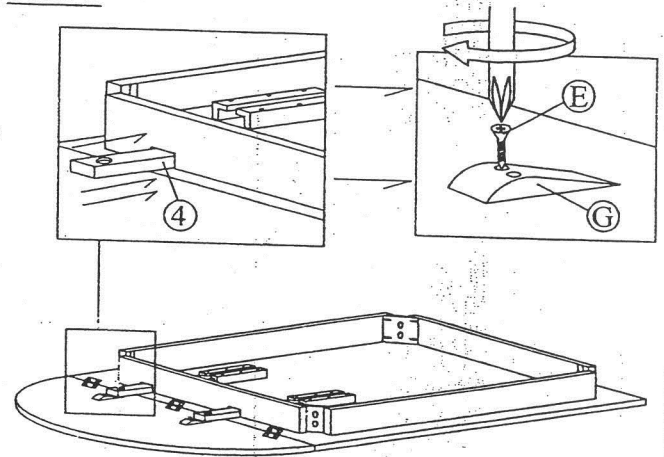

### STEP 3

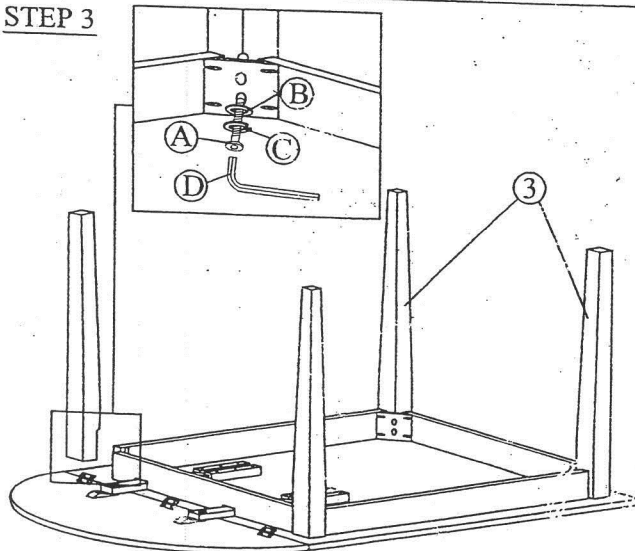

### STEP 4

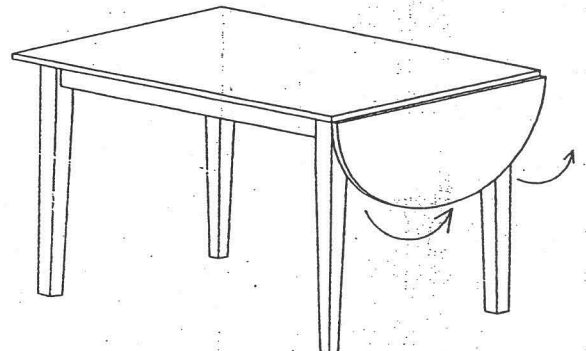





# ASSEMBLY INSTRUCTIONS



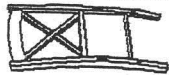

Read instruction carefully . Be sure you have all parts before you start assembling (see PART LIST & HARDWARE LIST) . To avoid scratching , lay the parts on a clean soft area such as carpet or rugs . Do not tighten all screws unless is instructed .

## BACK CHAIR

### PARTS LIST

NO	DESCRIPTION	QTY	NO	DESCRIPTION	QTY
1	CHAIR BACK 	1 PC	4	SIDE APRON 	2 PCS
2	CHAIR FRONT LEG 	1 PC	5	STRECHER 	2 PCS
3	CHAIR SEAT 	1 PC			

### HARDWARE LIST

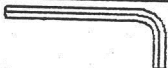
NO	DESCRIPTION	QTY	NO	DESCRIPTION	QTY
A	JCBC SCREW 50MM 	4 PCS	D	SCREW 38MM 	4 PCS
B	SPRING WASHER 	4 PCS	E	SCREW 32MM 	3 PCS
C	FLAT WASHER 	4 PCS	F	ALLEN KEY 	1 PC

## FULLY SET UP

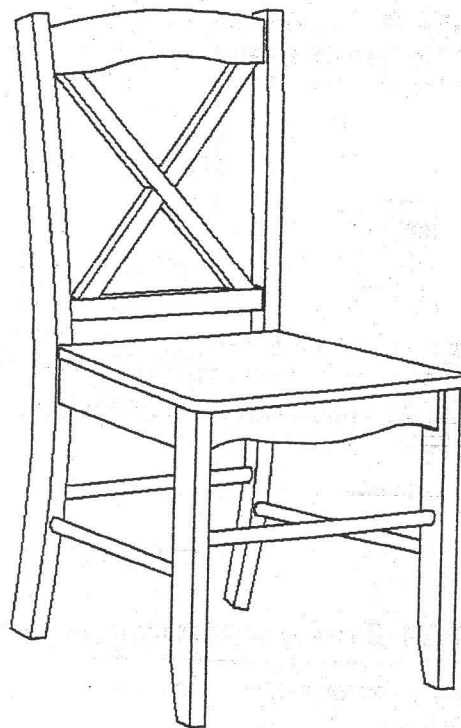

# ASSEMBLY INSTRUCTIONS

## STEP 1

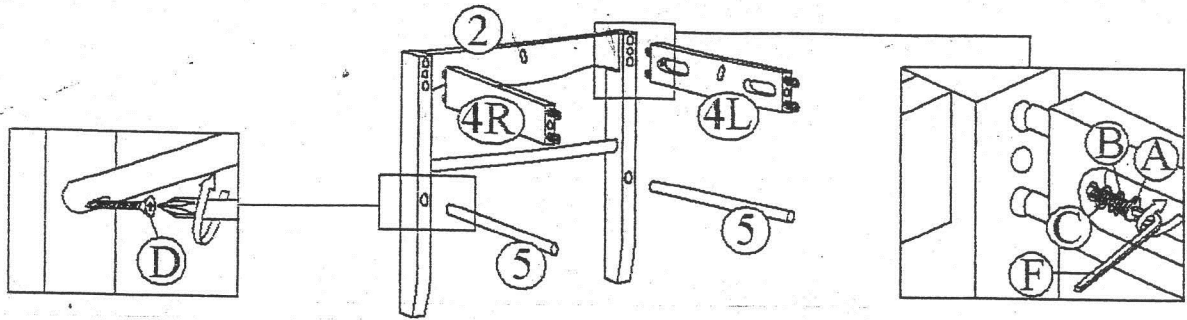

Use allen key (F) , JCBC screw 50MM (A) , spring washer (B) and flat washer (C) to assemble left and right side apron (#4L & 4R) to chair front leg (#2) .

Use philips screw driver and screw 38MM (D) to assemble both stretchers (#5) to chair front leg (#2) .  
Do not tighten screws .

## STEP 2

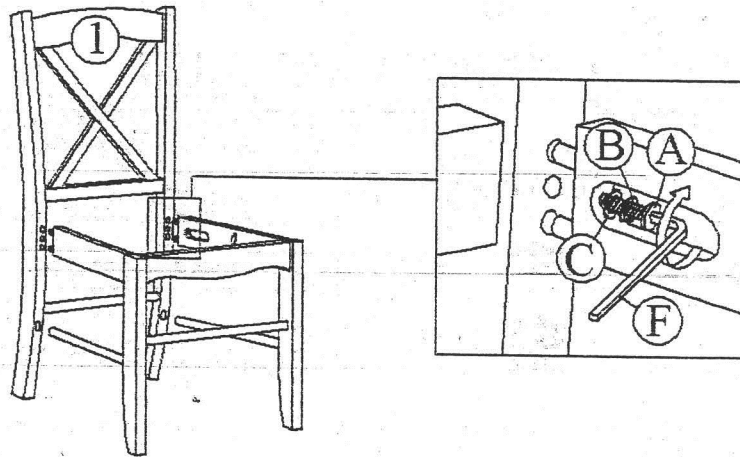

Use allen key (F) , JCBC screw 50MM (A) , spring washer (B) and flat washer (C) to assemble left and right side apron to chair back (#1) . Tighten all screws .

## STEP 3

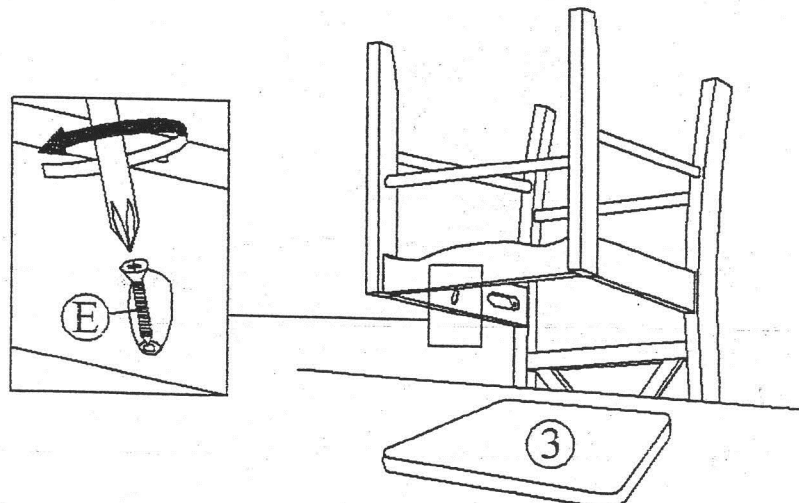

Use philips screw driver , screw 32MM (E) to assemble chair seat (#3) to seat . Tighten the screw .

After few days of initial assembly , the product may have acclimated to new environment , please retighten all hardware again .