

IMPORTANT, RETAIN FOR FUTURE REFERENCE: READ CAREFULLY

ASSEMBLY & INSTRUCTION MANUAL

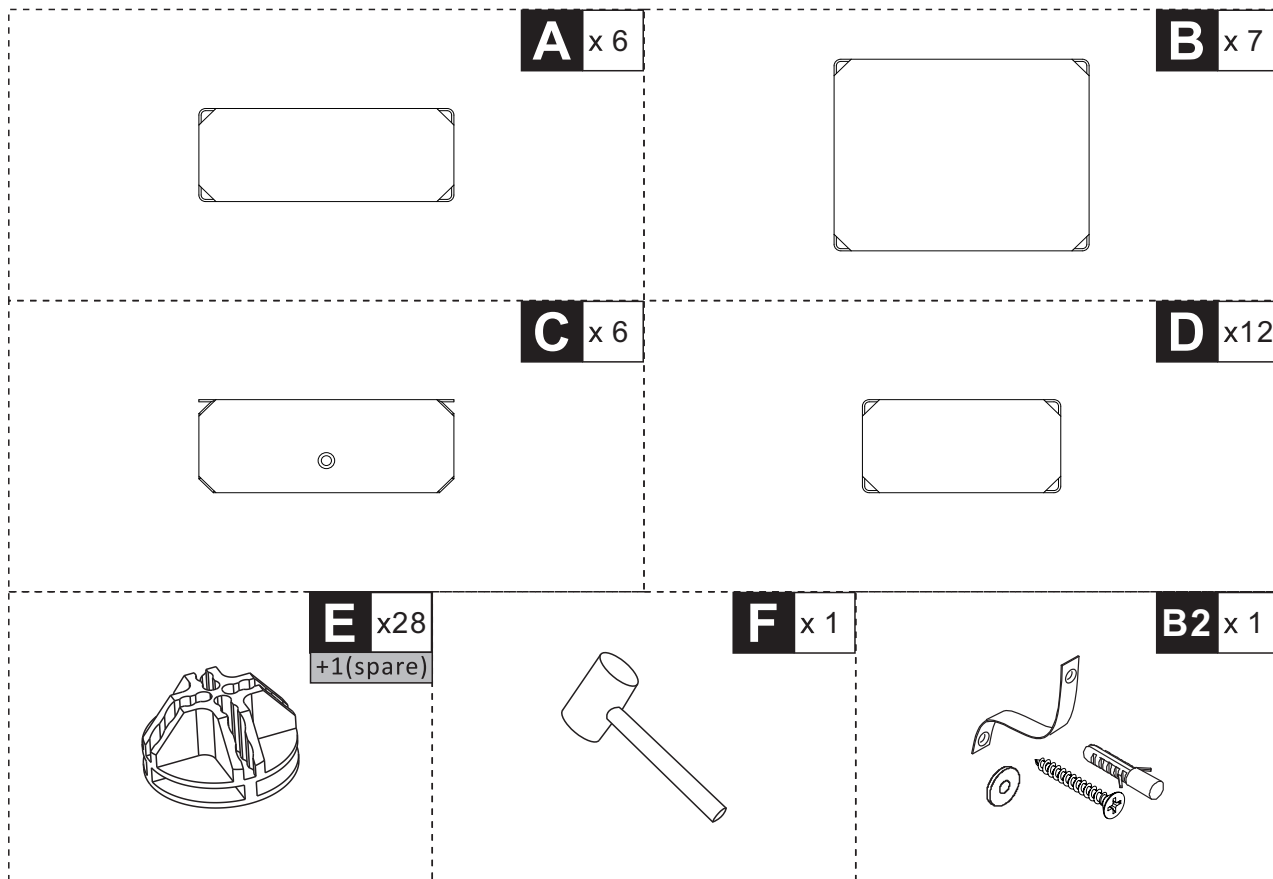

DE_ Bei der Montage achten Sie bitte darauf, die Vorderseite und Unterseite der Platte zu unterscheiden.

EN_ During assembly, please distinguish well the front and back of the plastic plate.

FR_ Durant le montage, veuillez faire la distinction entre les rectos et les versos des plaques.

IT_ Durante il montaggio, si prega di prestare attenzione a distinguere le parti anteriori dei pannelli dalle posteriori.

ES_ Durante el montaje, por favor, distinga bien la frente y el revés de la placa plástica.

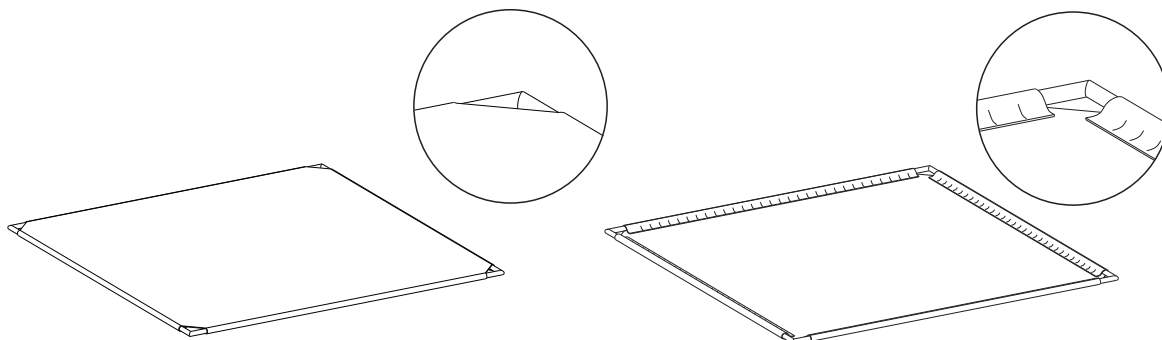

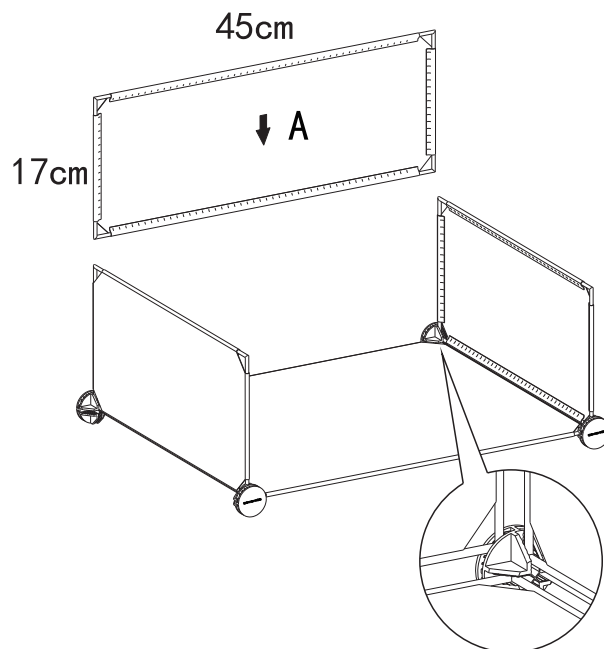
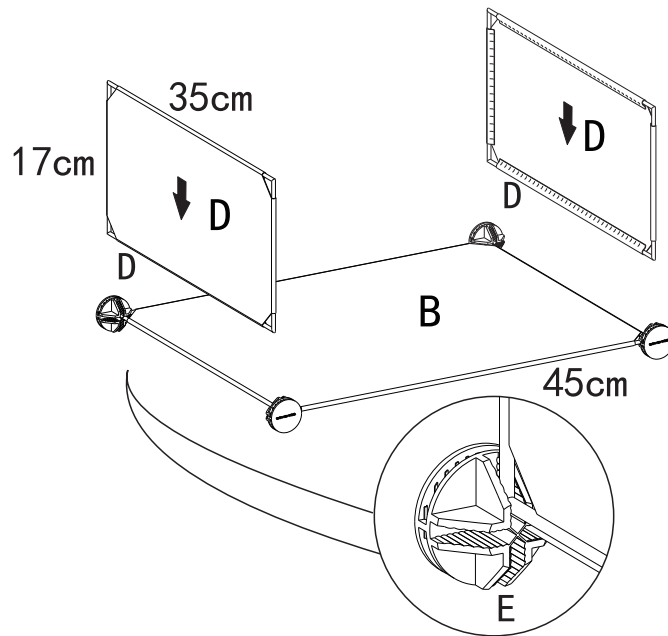
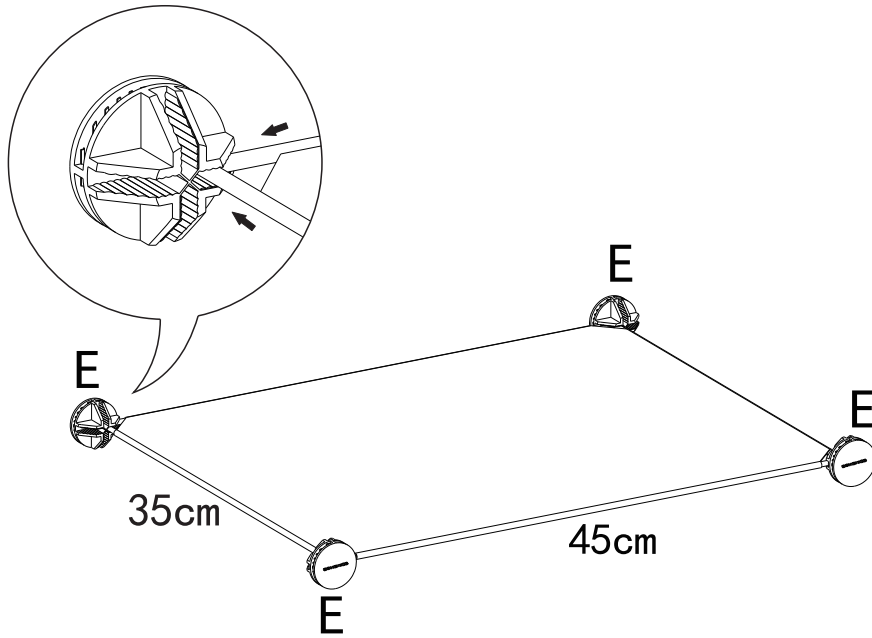

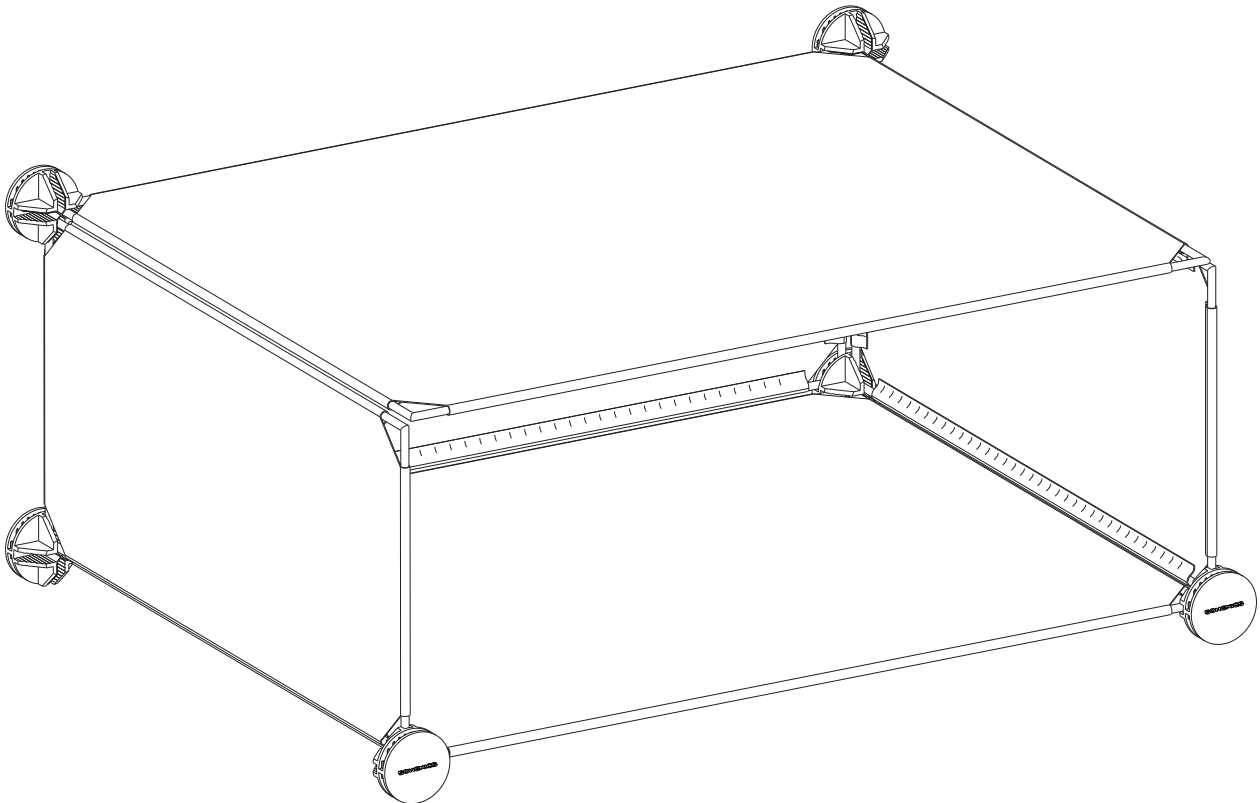
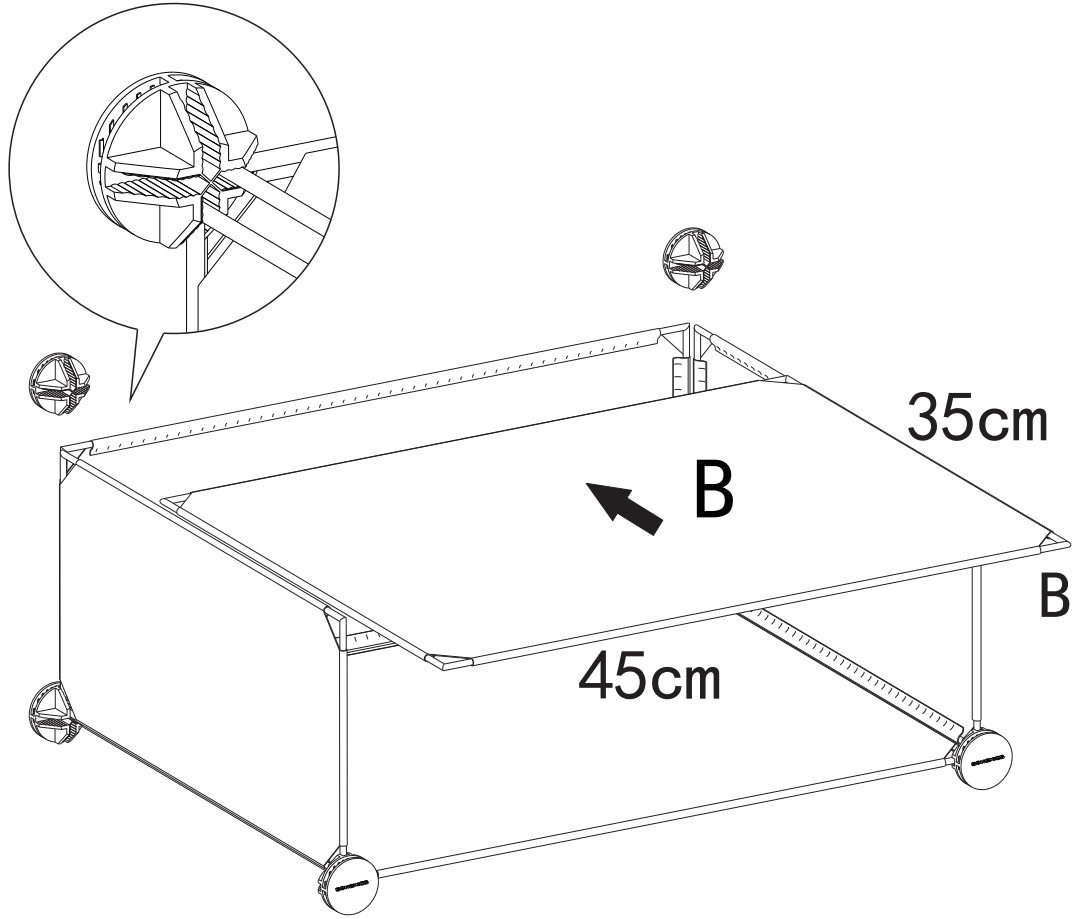

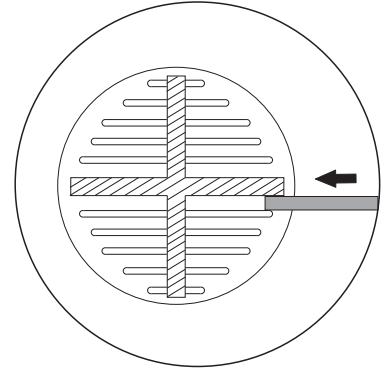
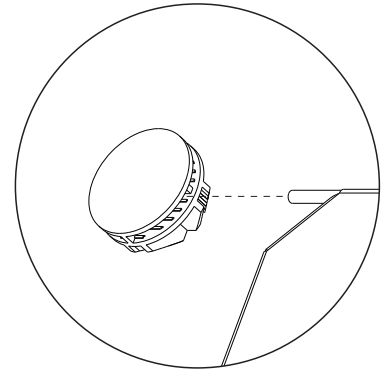
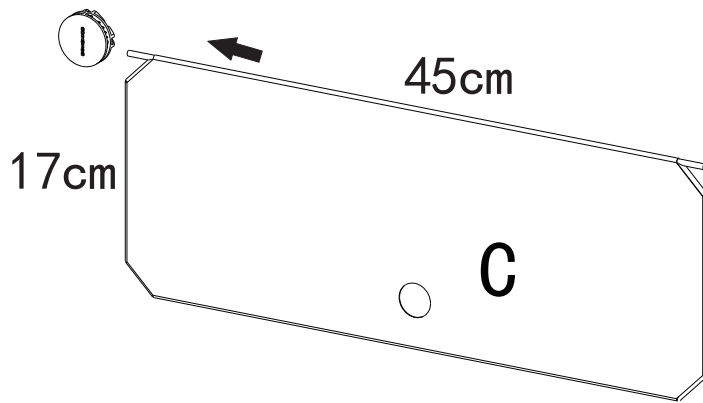

DE_ Beim Anbringen der Tür setzen Sie den Eisendraht an der Ecke entlang der inneren Riffel des Sektors eines Verbindungsstücks ein und der Eisendraht sollte "ganz unten" im Steckschlitz sitzen.

EN_ Please insert the wire of door panel into connectors totally during assembly. The door panels should be inserted into the inner slot which is in the middle of connectors.

FR_ Pour le montage de la porte, veuillez insérer profondément le fil en fer sortant de la porte dans la rainure centrale de la pièce de fixation.

IT_ Per installare le porte, si deve inserire albero di porta di filo in ferro nei fondi dei giunti e alla scanalatura centrale.

ES_ Para instalar la puerta, hay que insertar el alambre de hierro en el fondo de la ranura del conector a lo largo de la estría más interior. Por favor, monte las puertas después de completar los cubos del mismo nivel.

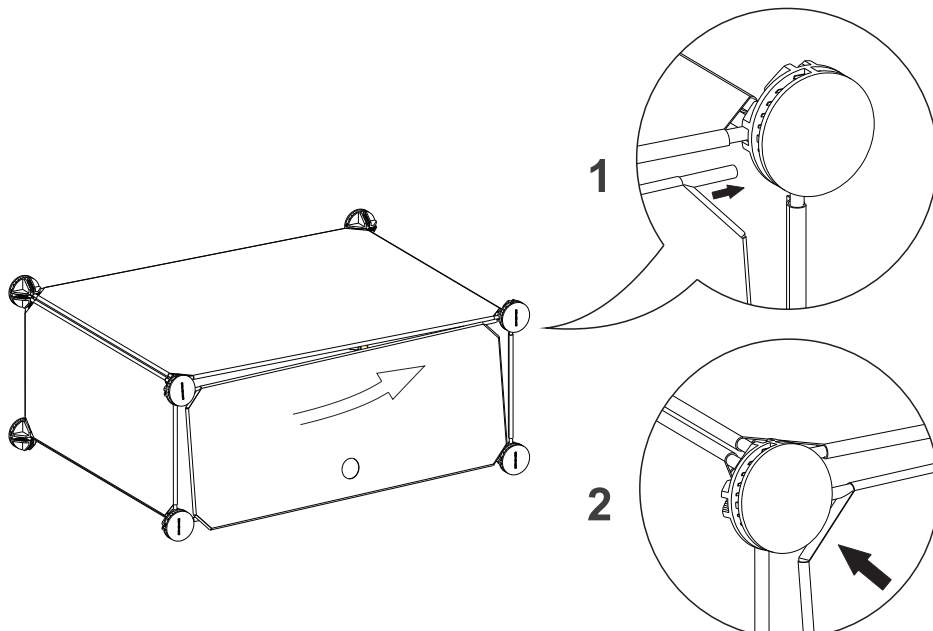

09

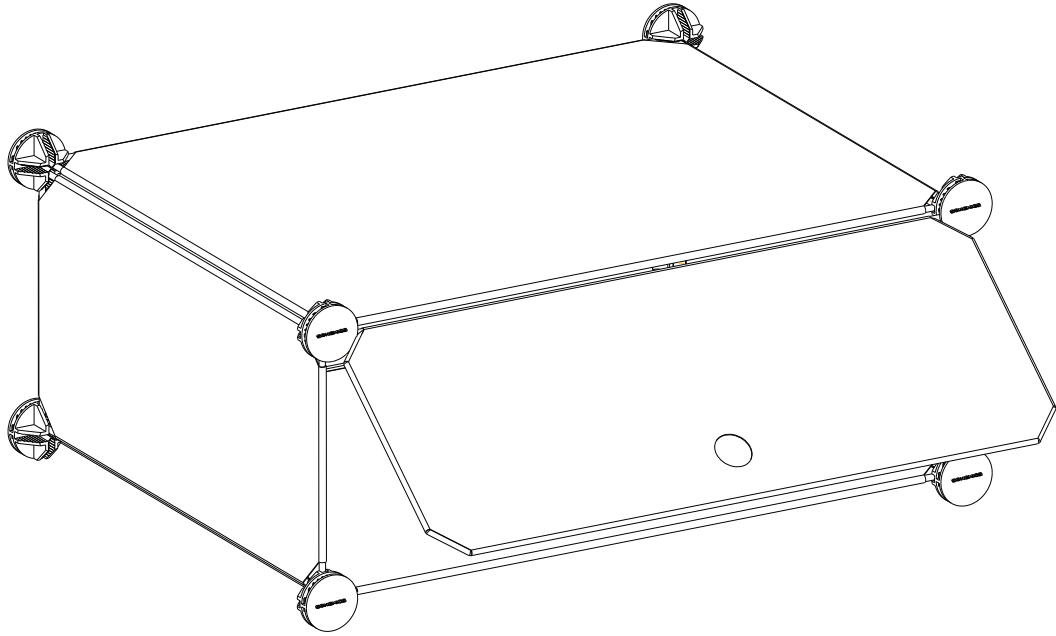

10

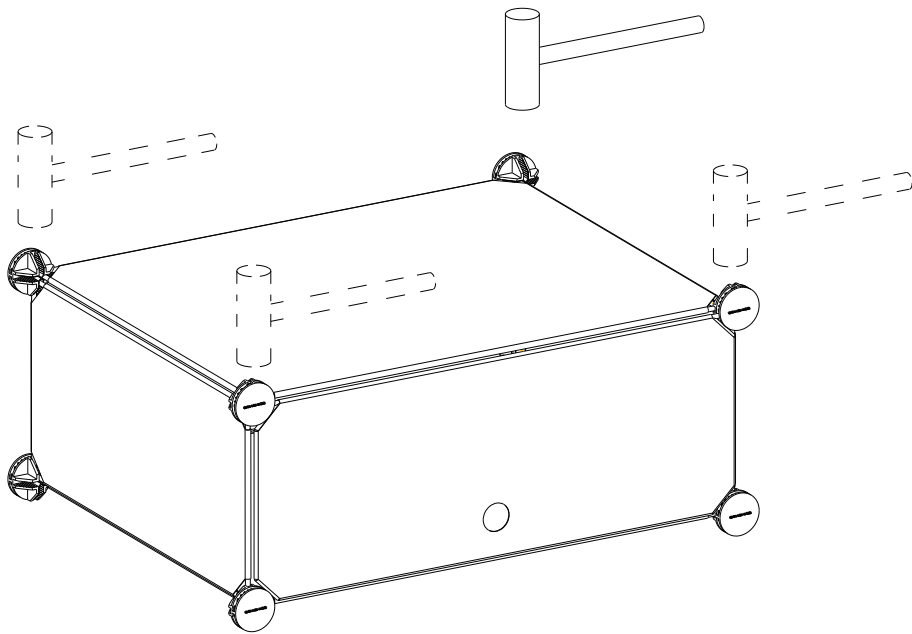

11

