











Assembly Instructions

Caution : You must read this before you proceed

Care & Maintenance

- ⊘  ● Not for commercial use. For residential use only.
- ✓  ● Furniture may scratch floors. We recommend using furniture pads to protect your floors.
- ⊘  ● Do not put hot items directly on furniture surface.
- ⊘  ● Do not clean furniture with harsh cleansers or polish.
- ⊘  ● Do not place furniture under direct sunlight.
- ⊘  ● Do not place furniture near heating or cooling vents.
- ⊘  ● Do not write on furniture without a padded barrier to protect the surface.
- ⊘  ● Do not place furniture outside . For indoor use only.
- ⊘  ● Stains may be removed with mild soap solution and damp cloth.
- ⊘  ● Children should not climb or jump on the furniture.
- ✓  ● Dust and pick-up spills using a clean, non-colored, lint-free cloth.



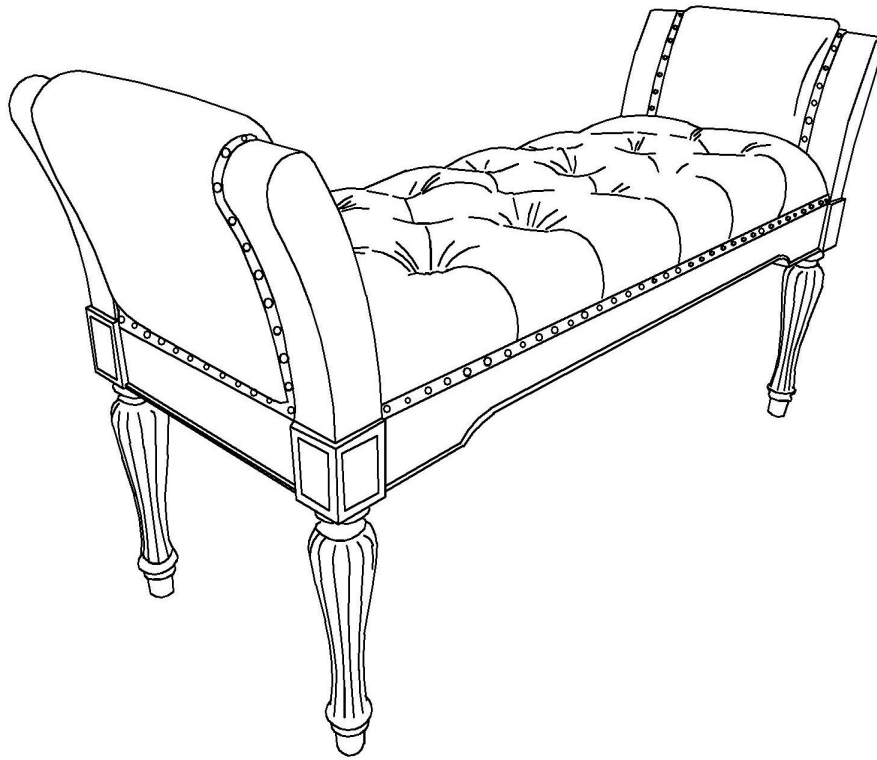

BENCH









Parts List



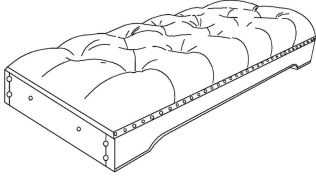
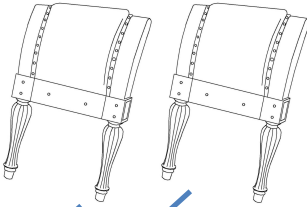

Label	Picture	Description	QTY
A		Bench	1
B		Leg	2

Hardware

Label	Picture	Description	QTY
①		Allen Wrench 5mm	1
②		Bolt (M8*89mm)	9
③		Spring Washer (M8)	9
④		Flat Washer (M8)	9
⑤		Wood Tenon (Φ10x30mm)	5

Assembly Preparation

<p>Before Beginning Assembly:</p>	 <p>A</p>  <p>B</p>	<p>① </p> <p>②  X9</p> <p>③  X9</p> <p>④  X9</p> <p>⑤  X5</p>
-----------------------------------	--------------------------------------------------------------------------------------------------------------------------------------------------------------------------------------------	--------------------------------------------------------------------------------------------------------------------------------------------------------------------------------------------------------------------------------------------------------------------------------------------------------------------------------------------------------------------------------------------------------------------------------------------------------------------------------------------------------

-  • Read instructions, cover to cover-
-  • Have 2 adults on hand for assembly-
-  • Do not assemble on flooring or carpet-
-  • Assemble on a clean non-marring surface (packing foam)-
-  • Save all packaging until finished-

Assembly Steps

Overview

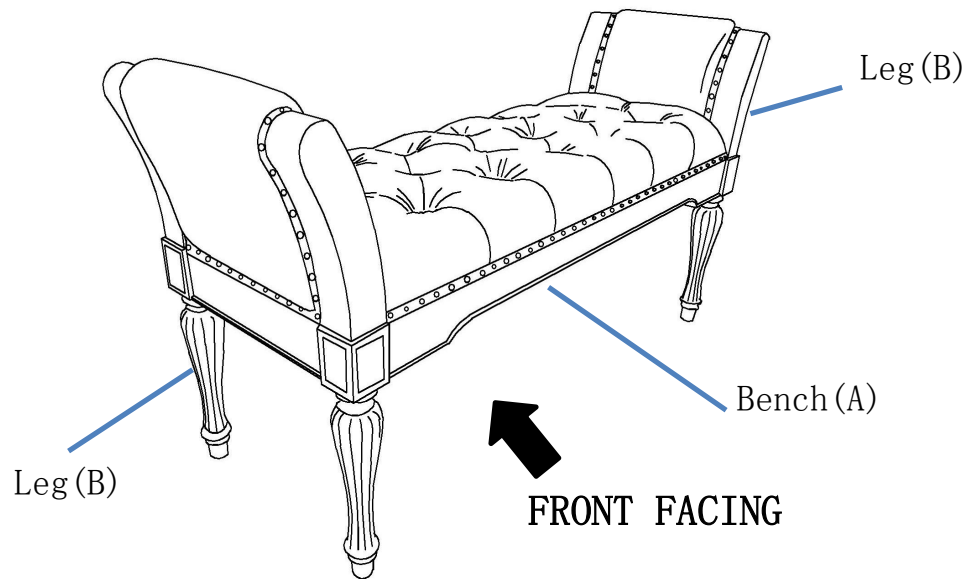

This Bench has multiple parts and may require up to 30 minutes to assemble. To give you an overview of the Bench parts, the above picture is to help you put the various parts into perspective. Please read through the instructions below to familiarise yourself with the parts and steps before assembly

Step 1

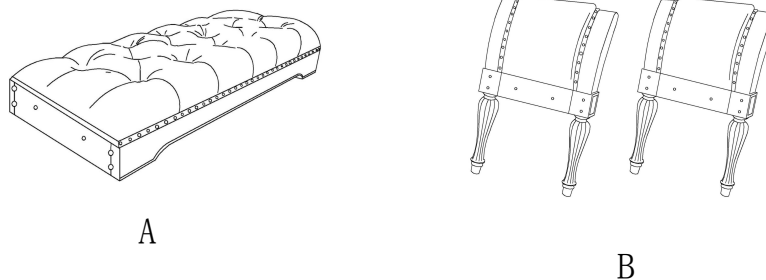

Take out the Bench(A) and legs(B).

Step 2

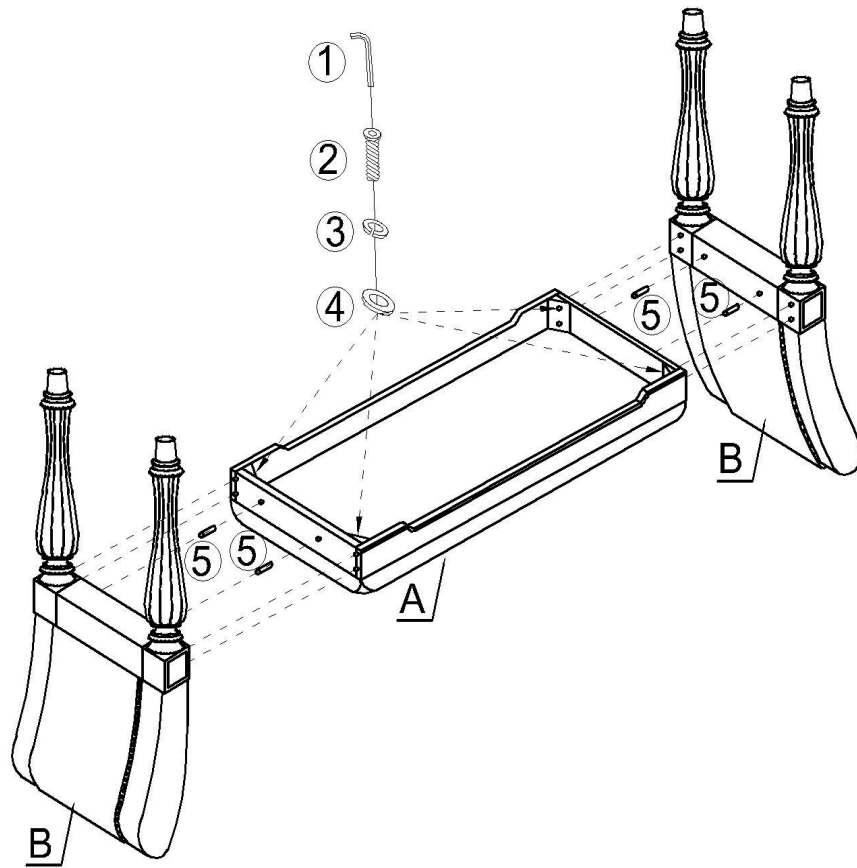

You will now have the Bench(A) and the Legs(B) facing upwards. Insert the Legs(B) completely vertical into the seat frame corner then attach them using Bolts (②)+ Spring Washers(③)+Flat Washers(④)and the Allen Wrench(①)+Wood Tenon(⑤).

At this point in the assembly.DO NOT fully tighten the connections.

Step 3

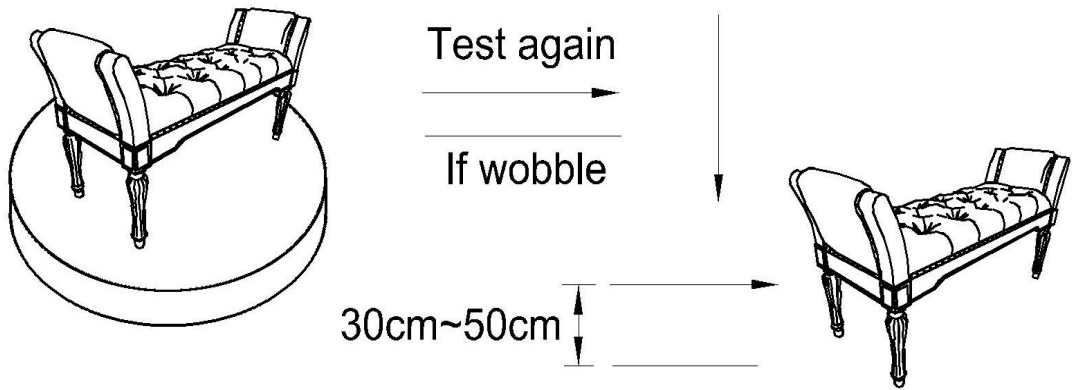

Place the Bench on a level Surface to check for wobbles.

If it wobbles, lift the Bench some 30cm to 50cm high from the ground.

Keep your feet and toes well away from the drop zone.

Drop Bench freely and vertically, with all Bottom hitting the ground at the same time.

This Drop Test will help to ensure that all Bolts and gaps reach full alignment status.

Test again for evenness on a Level Surface.

If no wobbles are found, proceed to tighten all the Bolts.

When tightening the Bolts, tighten sequentially.

DO NOT tighten any Bolts fully and then towards the next one. This may cause the frame to warp.

If there is still wobbles, loosen the Bolts and execute this same drop test.

Step 4

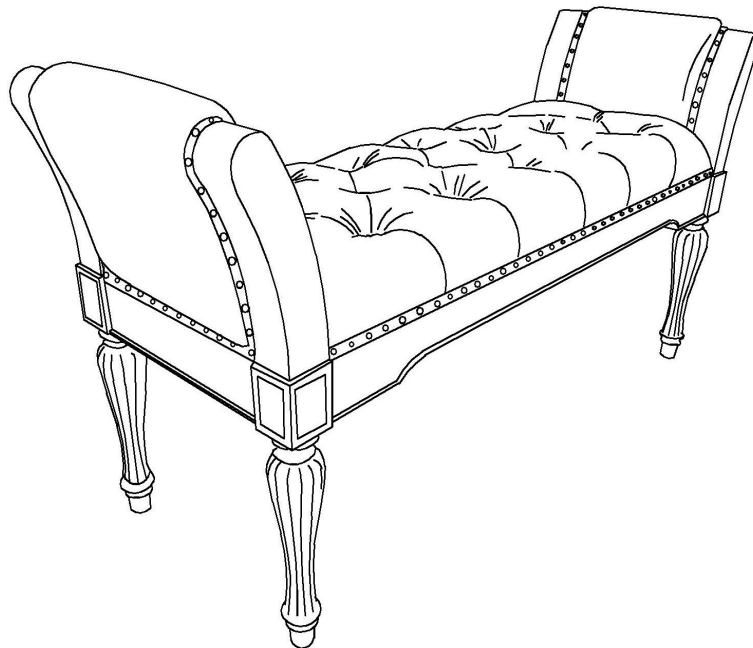

Your Bench is ready for use.

This Bench can only be used on a flat, level surface.