

# Office Chair Instruction Manual



English	-----	01-06
Deutsch	-----	07-12
Français	-----	13-18
Español	-----	19-24
Italiano	-----	25-31
日本語	-----	32-38

**Thank you for choosing our product! We strive to provide you with the best quality products and services in the industry.**

# Features

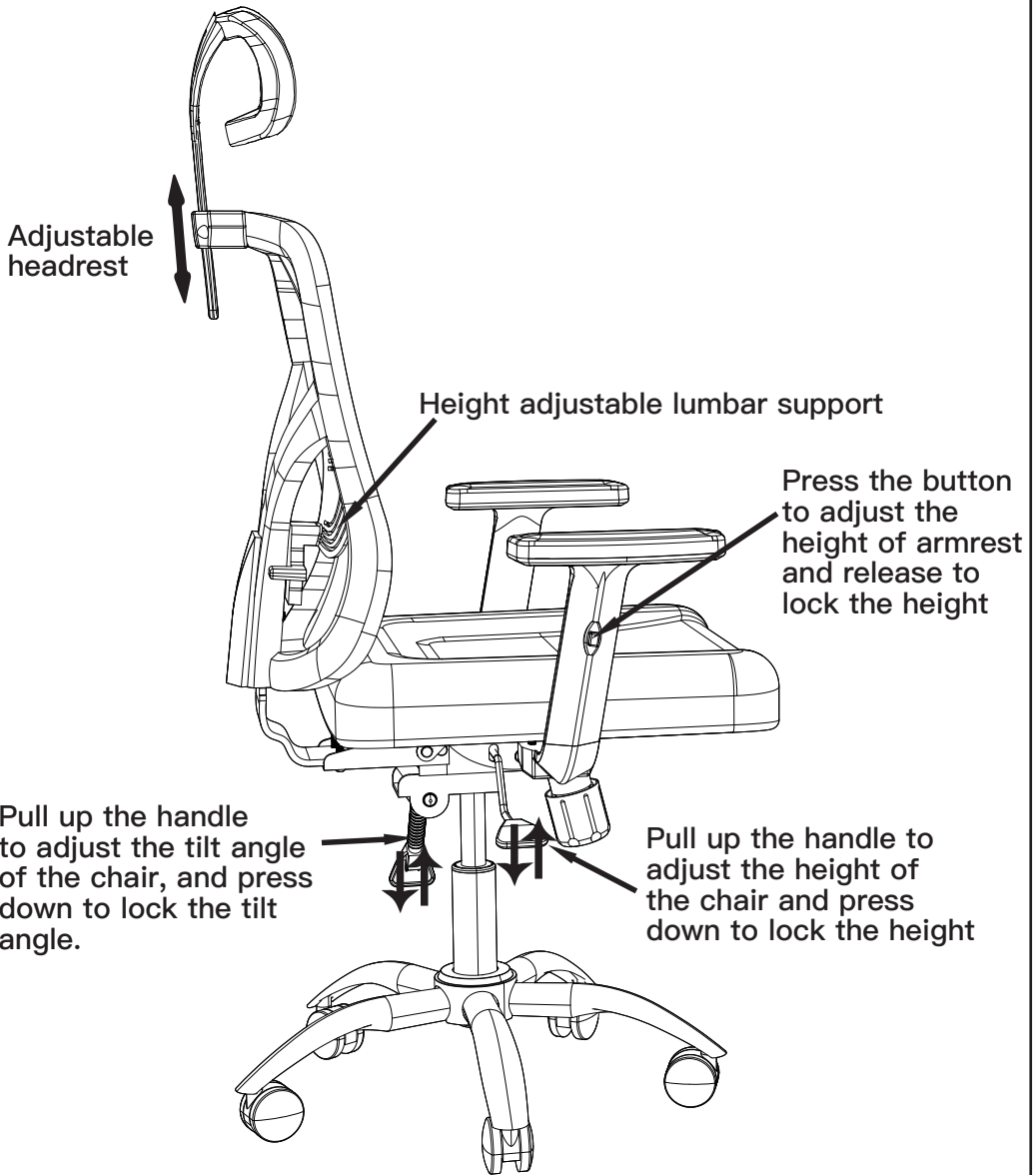

## IMPORTANT SAFETY INFORMATION

- Check package contents against supplied parts and hardware list to assure that all components were received undamaged. Do not use damaged or defective parts.
- Carefully read all instructions before attempting installation.
- One chair is confined to one person.
- Please put the chair on a flat place when using.
- Please do not let the children under 5 years old to sit the chair alone.
- Please do not sit on the armrest, which would cause damage to the chair and lead to damage.
- Don't stand on the chair or use it as a ladder or stair.
- Do not put heavy objects on the chair, or use it as trolley.
- Keep your hands away from the seat base mechanism besides the knob to avoid unwanted injuries.
- Do not use items with sharp or hook to scratch the chair.
- Keep the chair away from the fire.
- Please do not sit on the front of the seat to avoid dumping. Please sit at the end of the chair completely. When standing up from the sitting position, please clench the armrests of the chair.
- Please do not lift your legs up while tilting the backrest backwards to avoid dumping.

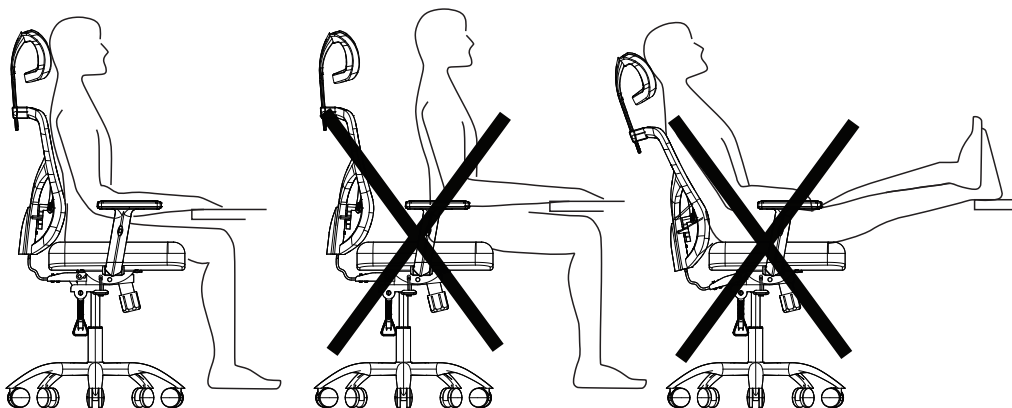

## Supplied Parts and Hardware List

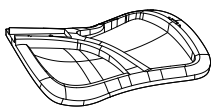

Back

A x1

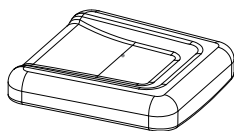

Seat

B x1



Leg

C x1



Leg Cover

D x1

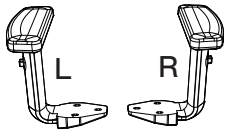

Armrest  
E x1



Castor  
F x5

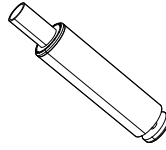

Gas Lift Cylinder  
G x1



Mechanism  
H x1

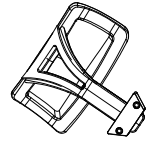

Headrest  
I x1

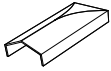

Plastic Cover  
J x1



Back Stay  
K x1



Short Bolt  
a x4

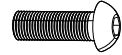

Medium Bolt  
b x10

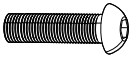

Long Bolt  
c x2

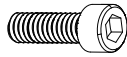

Big Bolt  
d x3

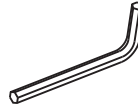

Small Allen Key  
x1

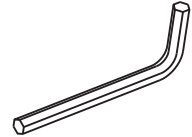

Large Allen Key  
x1

## Installation Steps

1

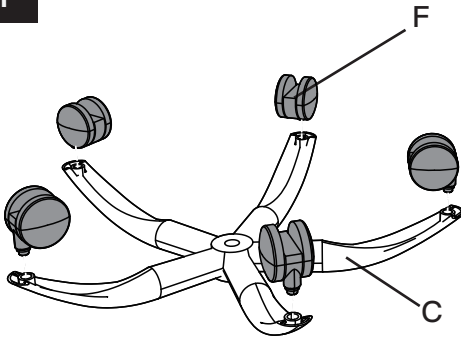

Rotate and press the 5pcs castors hard into the 5 holes on the leg.

2

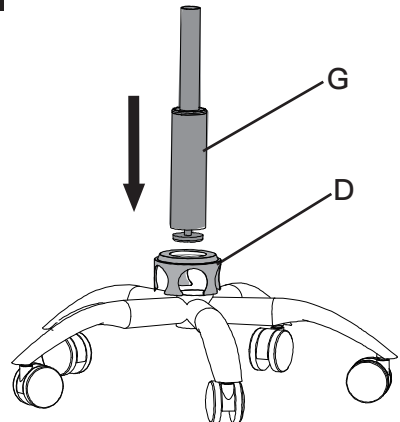

Press the leg cover and gas lift cylinder into the leg.

3

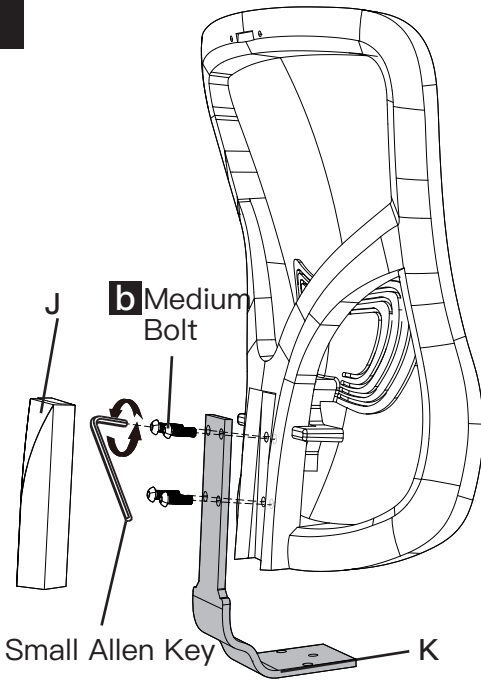

Secure the back stay to the back with 4pcs medium bolts [b], then attach the plastic.

4

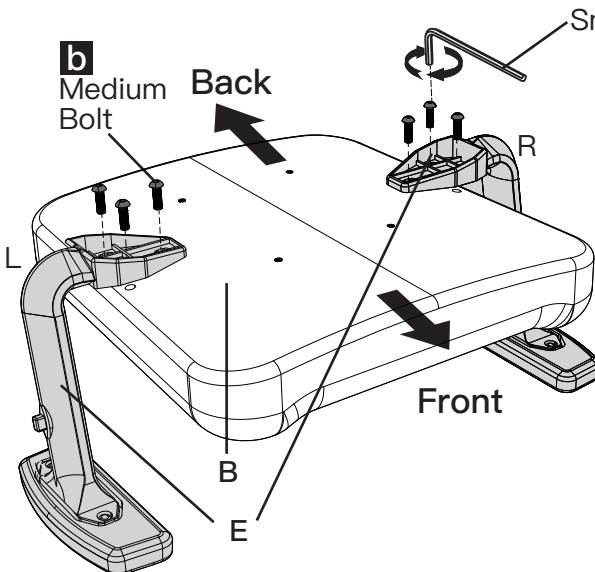

Connect armrests to the seat with 6 pcs medium bolts [b] and small Allen key.

5

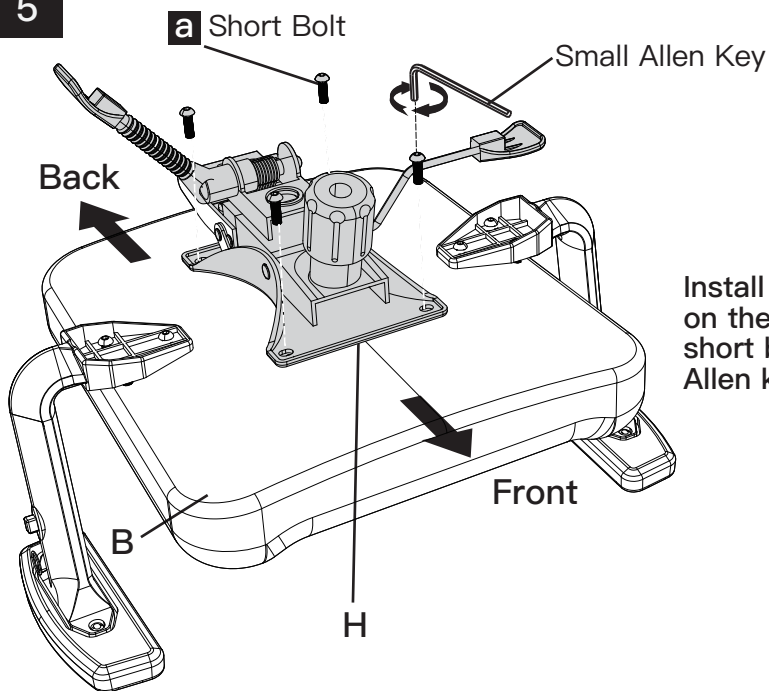

Install the mechanism on the seat with 4 pcs short bolts [a] and small Allen key.

6 6-1. Choose proper position when you attach the back [A] to the mechanism

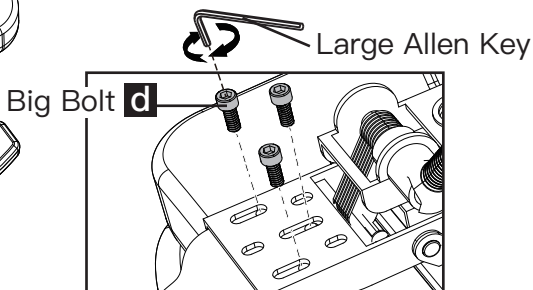
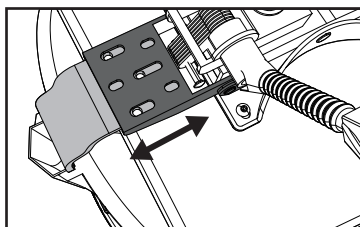
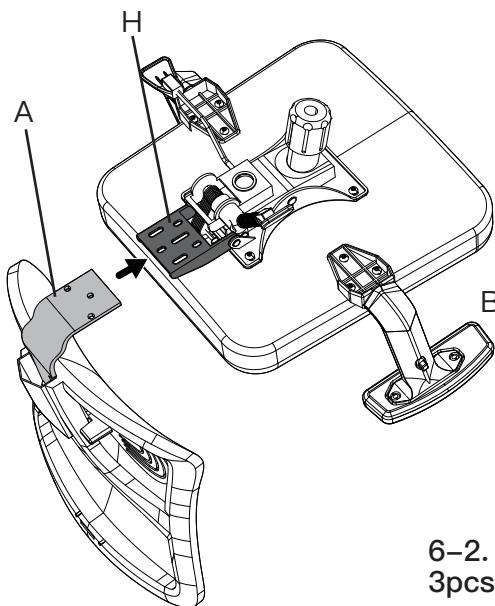

6-2. Secure the back [A] to the seat with 3pcs big bolts [d] and Allen key.

7

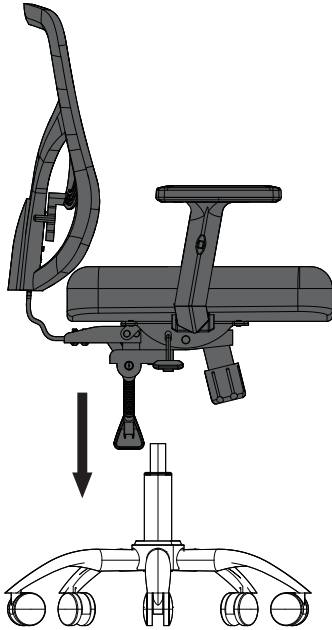

Align the hole on mechanism with gas lift cylinder, then press the mechanism down to secure it to gas lift cylinder.

8 Connet the headrest to back with 2 pcs long bolts.

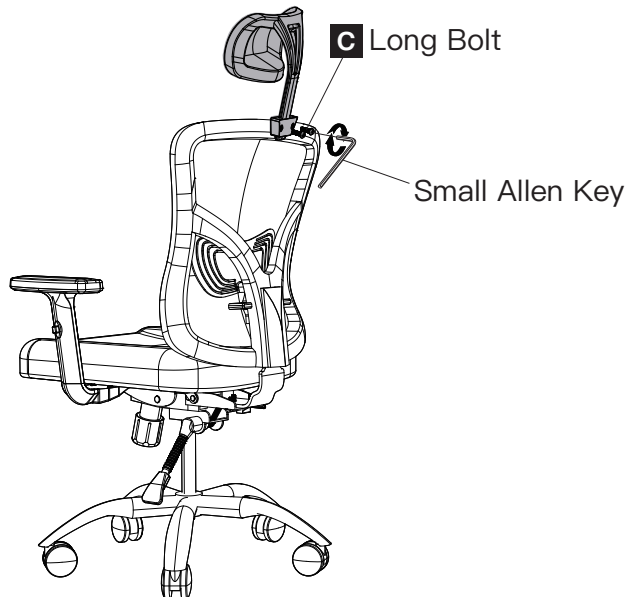

# Eigenschaften

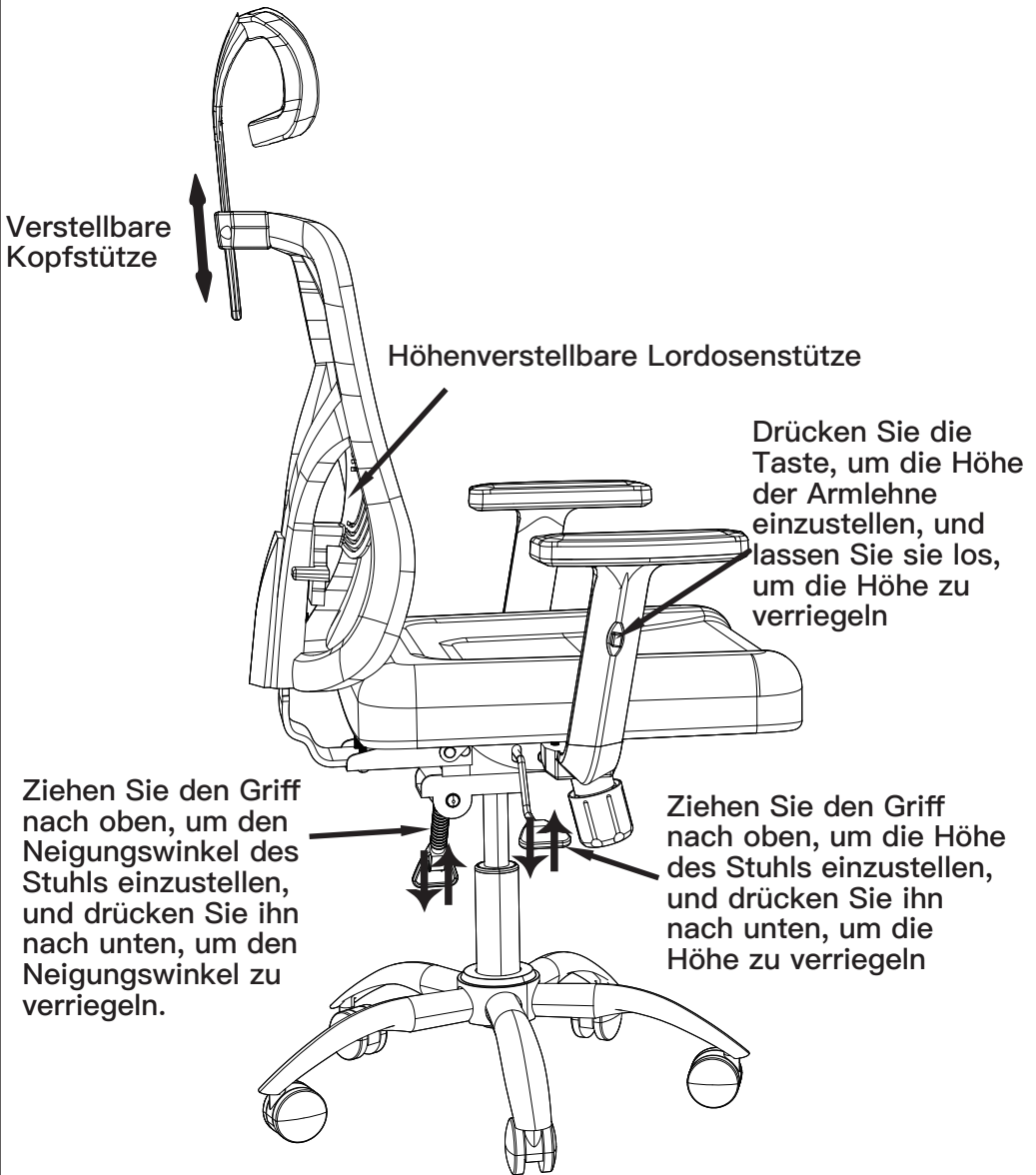

## WICHTIGE SICHERHEITSHINWEISE

- Überprüfen Sie den Inhalt des Pakets anhand der bereitgestellten Teile- und Hardwareliste, um sicherzustellen, dass alle Komponenten intakt sind. Verwenden Sie keine beschädigten oder defekten Teile.
- Bitte lesen Sie alle Anweisungen sorgfältig durch, bevor Sie versuchen, sie zu installieren.
- Ein Stuhl kann nur von einer Person benutzt werden.
- Bitte stellen Sie den Stuhl auf einen flachen Platz, wenn Sie ihn benutzen.
- Bitte lassen Sie Kinder unter 5 Jahren nicht alleine auf einem Stuhl sitzen.
- Bitte setzen Sie sich nicht auf die Armlehnen, da dies den Stuhl beschädigen und Schäden verursachen kann.
- Stellen Sie sich nicht auf einen Stuhl und benutzen Sie ihn als Leiter oder Treppe.
- Stellen Sie keine schweren Gegenstände auf den Stuhl und verwenden Sie ihn nicht als Wagen.
- Halten Sie Ihre Hände neben dem Knopf vom Sitzfußmechanismus fern, um unerwünschte Verletzungen zu vermeiden.
- Verwenden Sie keine scharfen Gegenstände oder Haken, um den Stuhl zu zerkratzen
- Halten Sie den Stuhl vom Feuer fern.
- Bitte setzen Sie sich nicht auf die Vorderseite des Sitzes, um ein Abladen zu vermeiden, und setzen Sie sich vollständig an das Ende des Stuhls. Wenn Sie aus der Sitzposition aufstehen, drücken Sie bitte die Armlehnen des Stuhls zusammen.
- Bitte heben Sie Ihre Beine nicht an, während Sie die Rückenlehne nach hinten kippen, um ein Entleeren zu vermeiden.

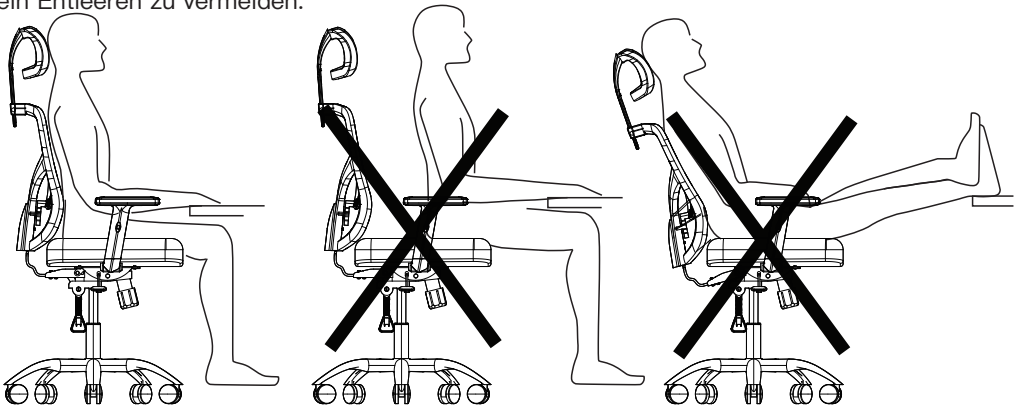

## Mitgelieferte Teile

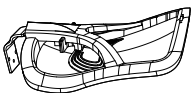

Rücken

A x1



Sitz

B x1

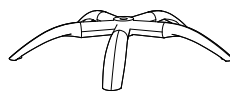

Bein

C x1



Beinabdeckung

D x1

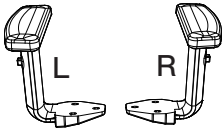

Armlehne  
E x1



Rolle  
F x5

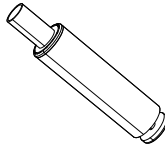

Gasliftflasche  
G x1

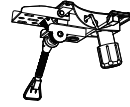

Mechanismus  
H x1

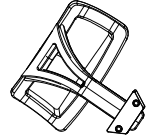

Kopfstütze  
I x1

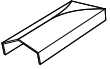

Plastikhülle  
J x1

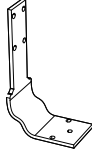

Rückenstütze  
K x1



Kurzer Bolzen  
a x4

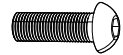

Mittlerer Bolzen  
b x10

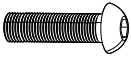

Langer Bolzen  
c x2

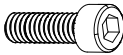

Großer Bolzen  
d x3

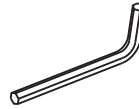

Kleiner  
Inbusschlüssel  
x1



Großer  
Inbusschlüssel  
x1

## Installationsschritte

1

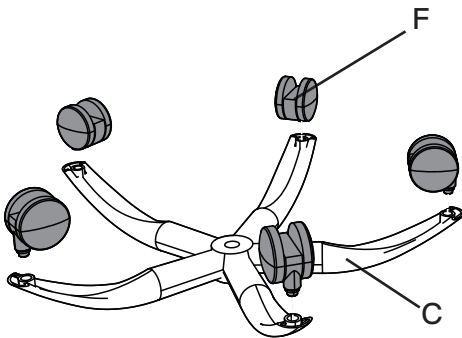

Drehen Sie die 5 Rollen und drücken Sie sie fest in die 5 Löcher des Beins.

2

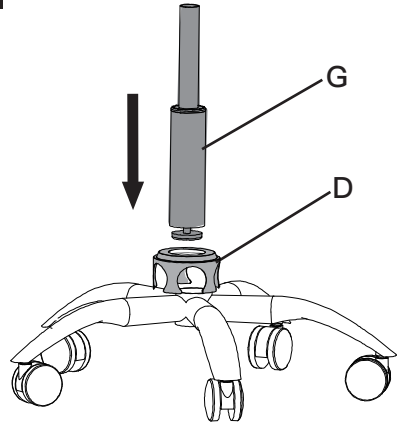

Drücken Sie die Beinabdeckung und den Gasliftzylinder in das Bein.

3

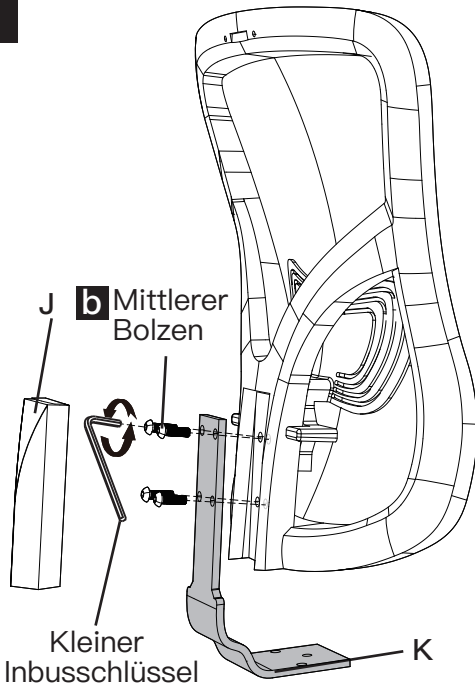

Befestigen Sie die Rückenstütze mit 4 Stück Mittelbolzen [b] an der Rückseite und befestigen Sie dann den Kunststoff.

4

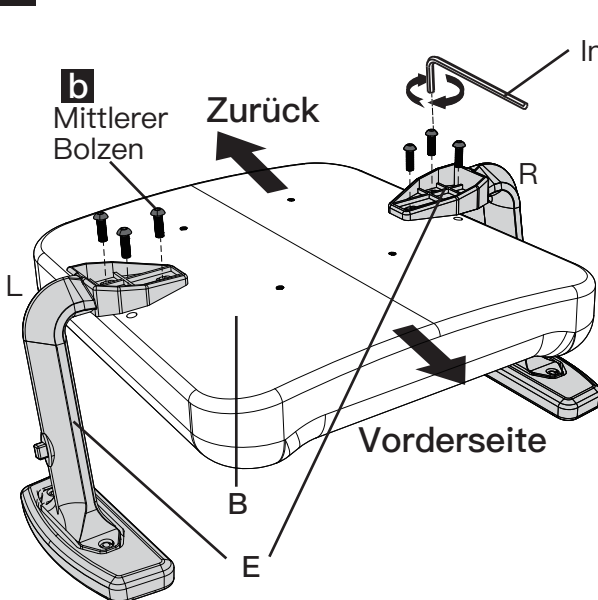

Verbinden Sie die Armlehnen mit 6-teiligen Mittelschrauben [b] und einem kleinen Inbusschlüssel mit dem Sitz.

5

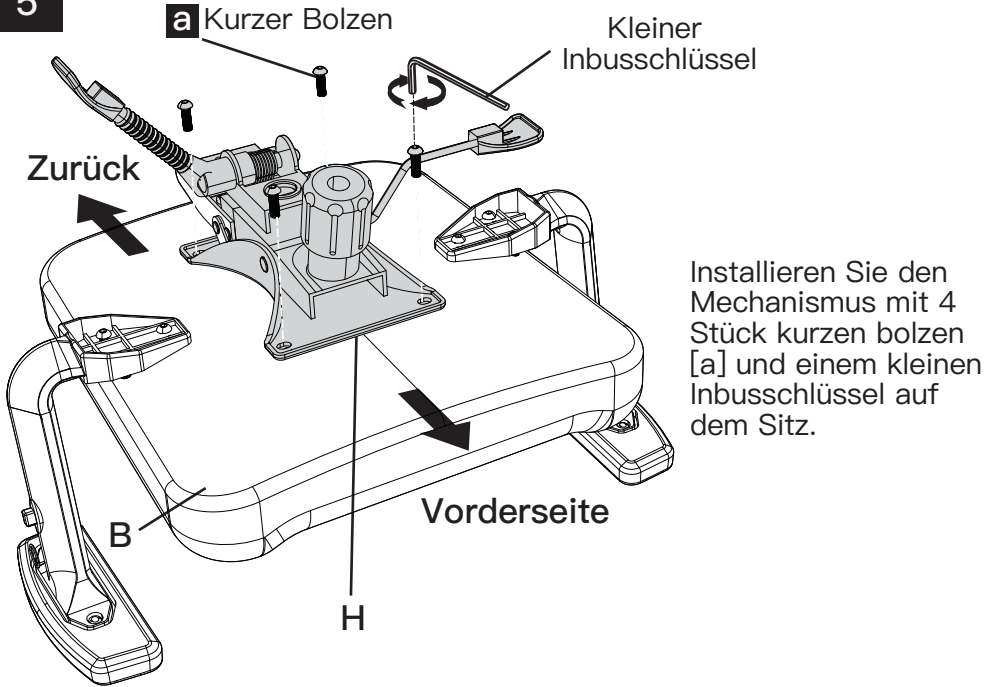

6

6-1. Wählen Sie die richtige Position, wenn Sie den Rücken [A] am Mechanismus befestigen

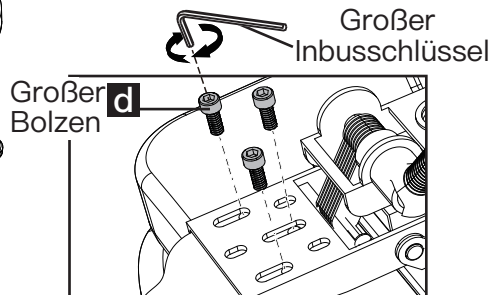
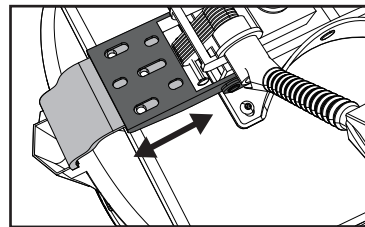
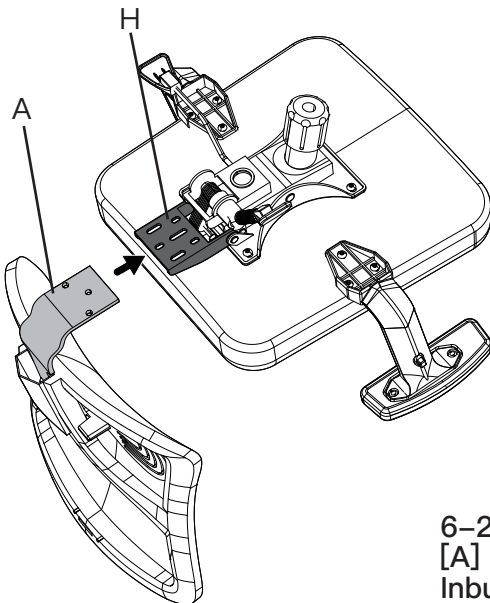

6-2. Befestigen Sie die Rückenlehne [A] mit 3-teiligen großen bolzen [d] und Inbusschlüssel am Sitz.

7

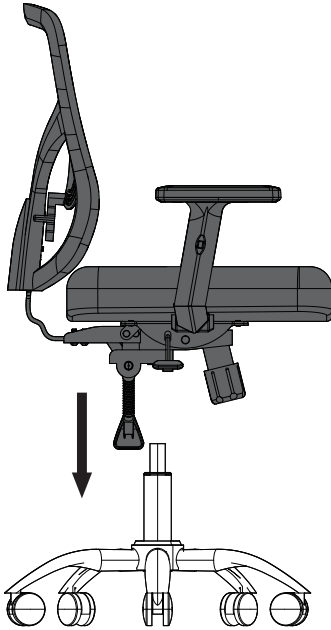

Richten Sie das Loch am Mechanismus an der Gasliftflasche aus und drücken Sie den Mechanismus nach unten, um ihn an der Gasliftflasche zu befestigen.

8 Verbinden Sie die Kopfstütze mit 2 Stück langen bolzen mit dem Rücken.

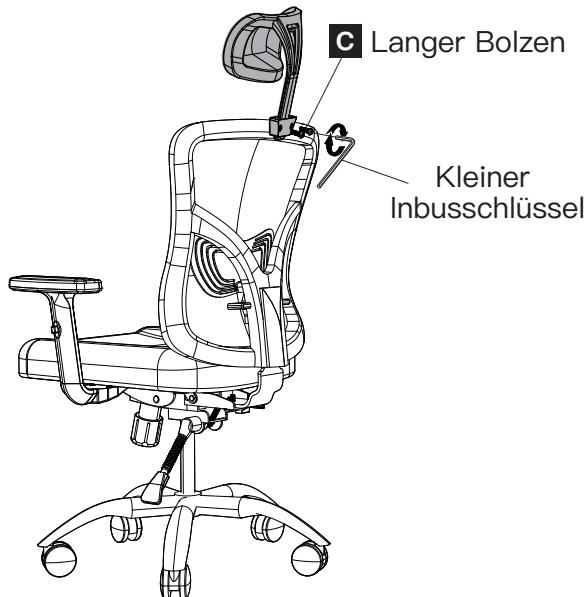

# Caractéristiques

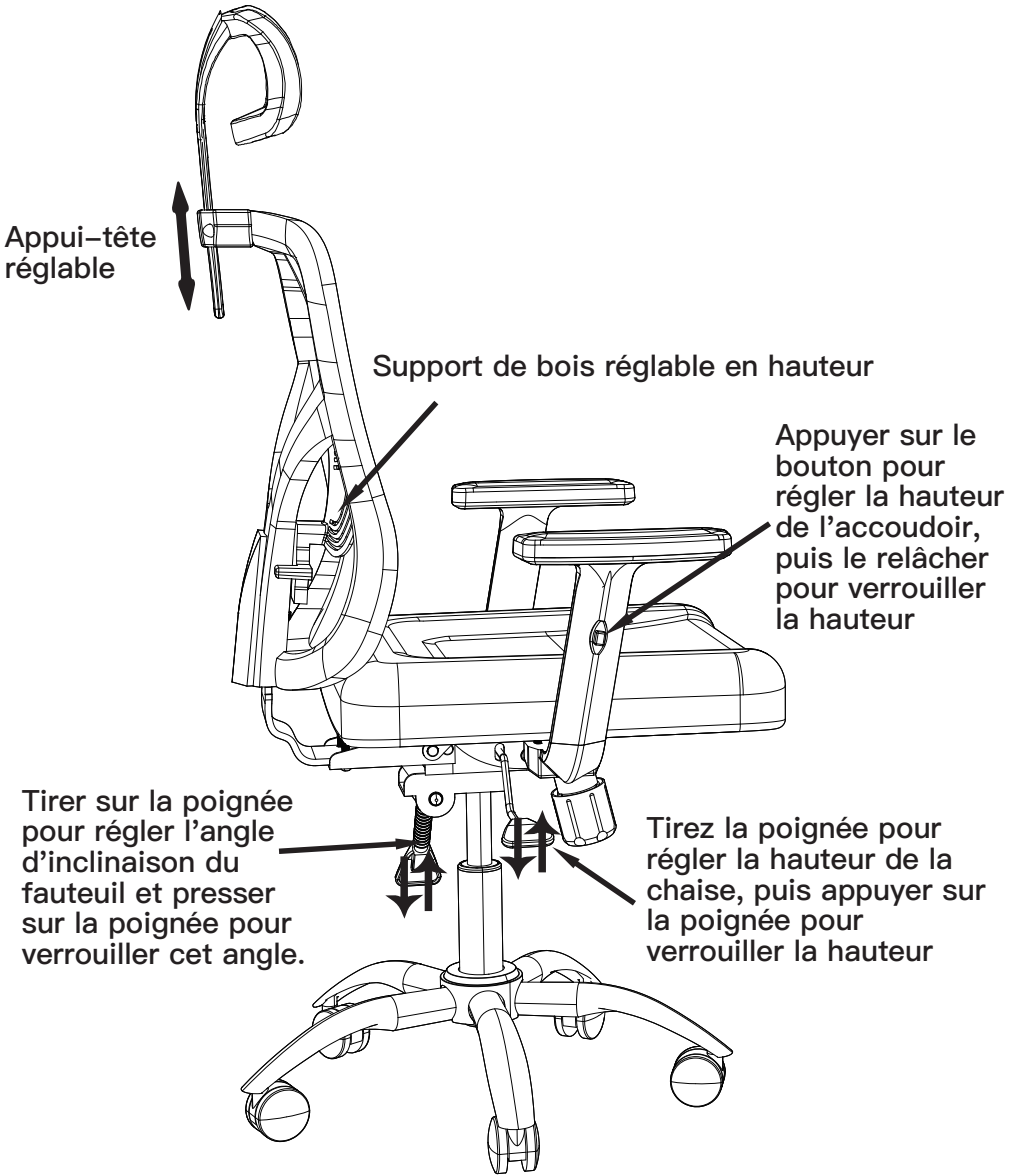

## INFORMATIONS DE SÉCURITÉ IMPORTANTES

- Vérifier l'emballage par rapport aux pièces fournies et à la liste des matériels, pour assurer que tous les composants ont été reçus en bon état. Ne pas utiliser de pièces endommagées ou défectueuses.
- Lire attentivement toutes les instructions avant l'installation.
- Une chaise est seulement réservée à une personne.
- Mettre la chaise à un endroit plat lors de l'utilisation.
- Ne pas laisser les enfants de moins de 5 ans s'asseoir seuls sur la chaise.
- Ne pas vous asseoir sur l'accoudoir, car cela peut endommager la chaise et causer d'autres dommages.
- Ne pas vous tenir debout sur la chaise ; ne pas utiliser la chaise comme échelle ou escalier.
- Ne pas placer des objets lourds sur la chaise ; ne pas utiliser la chaise comme chariot.
- Garder les mains éloignées du mécanisme de base du siège en plus du bouton, pour éviter toute blessure indésirable.
- Ne pas utiliser d'objets pointus ou crochets pour rayer la chaise
- Éloigner la chaise du feu.
- Veuillez vous asseoir complètement au bout de la chaise, au lieu de l'avant du siège, pour éviter tout renversement. Lorsque vous vous levez de la position assise, veuillez tenir les bras de la chaise.
- Ne pas soulever vos jambes en inclinant le dossier vers l'arrière, pour éviter de tomber.

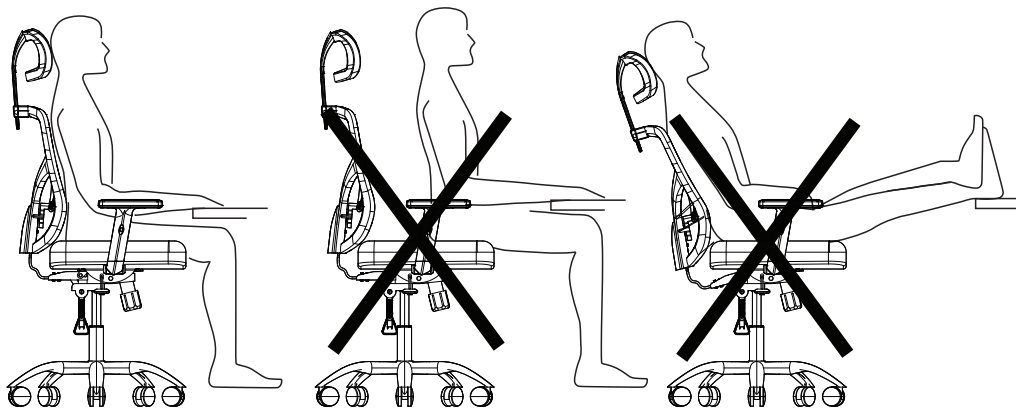

## Pièces fournies

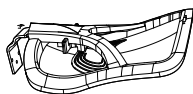

Arrière

A x1



Siège

B x1



Jambe

C x1



Couvre-jambe

D x1

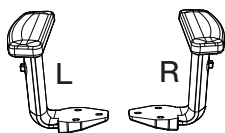

Accoudoir  
E x1



Roulette  
F x5

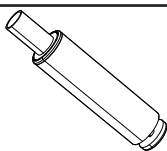

Cylindre de levage  
pneumatique  
G x1



Mécanisme  
H x1

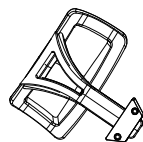

Appui-tête  
I x1

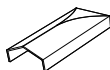

Couverture  
plastique  
J x1

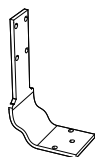

Support  
arrière  
K x1



Boulon court  
a x4

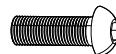

Boulon moyen  
b x10

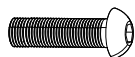

Long boulon  
c x2

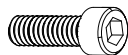

Gros boulon  
d x3

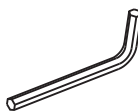

Petite clé Allen  
x1



Grande clé Allen  
x1

## Etapes d'installation

1

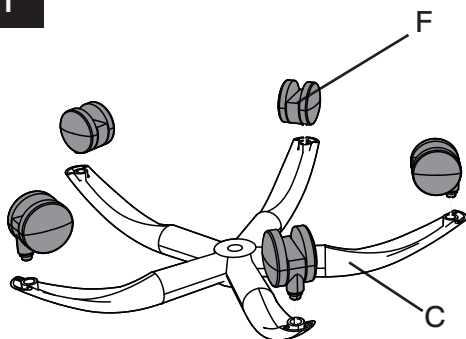

Faire pivoter et enfoncer fermement les 5 roulettes dans les 5 trous de la jambe.

2

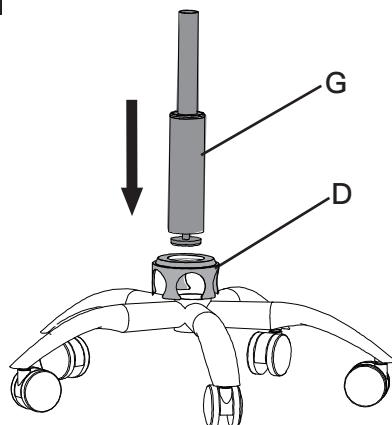

Enfoncer dans la jambe le couvre-jambe et le cylindre de levage pneumatique.

3

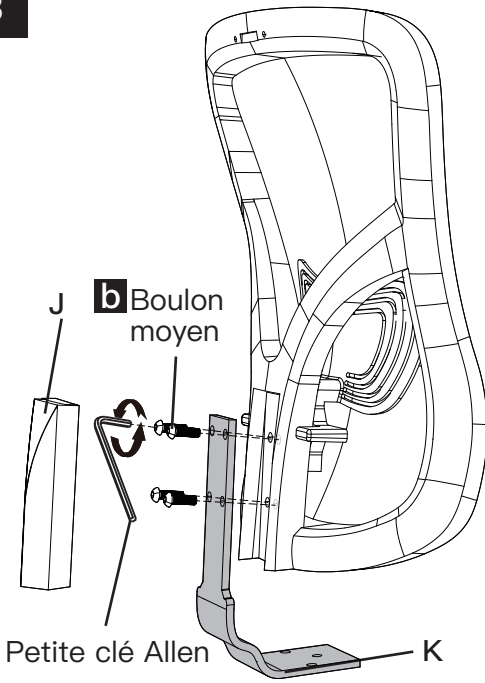

Fixer le support arrière au dossier avec 4 boulons [b], puis fixer les pièces en plastique.

4

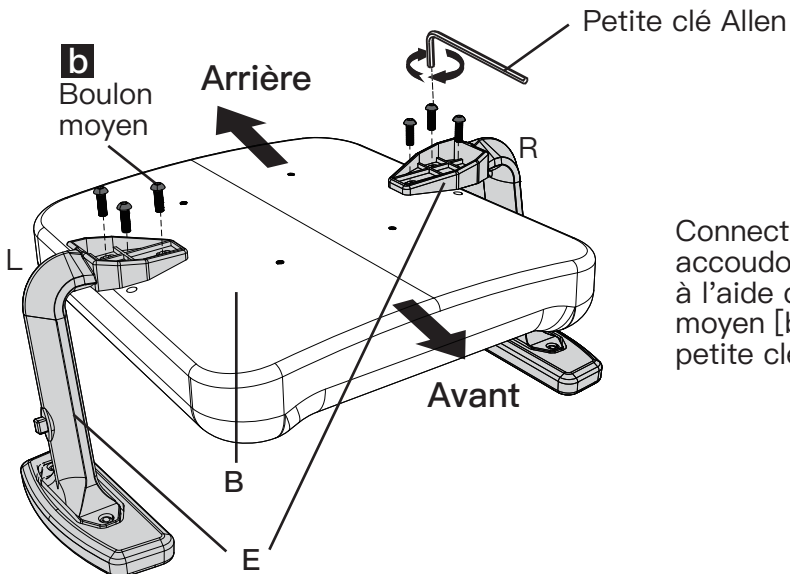

Connecter les accoudoirs au siège, à l'aide des 6 boulons moyen [b] et d'une petite clé Allen.

5

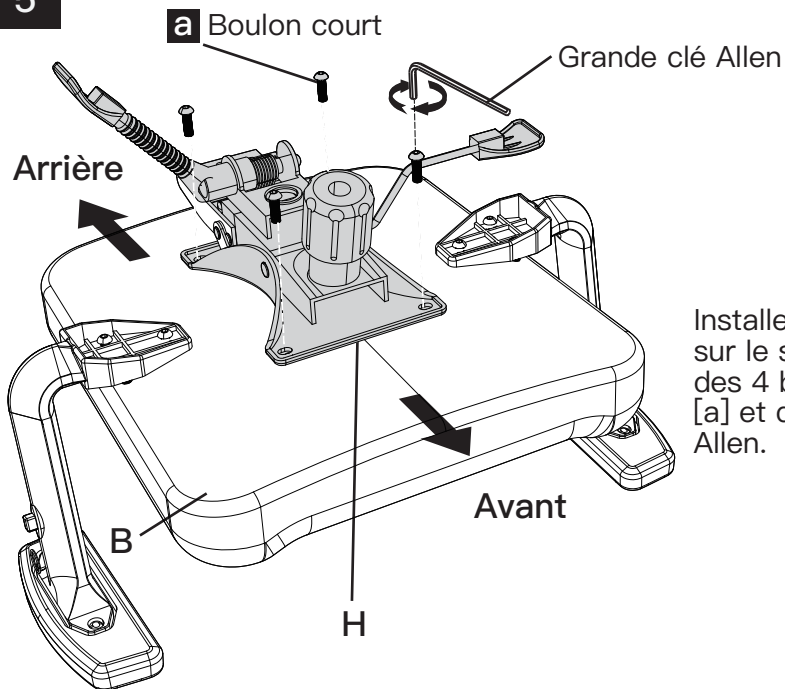

Installer le mécanisme sur le siège, à l'aide des 4 boulons courts [a] et d'une petite clé Allen.

6 6-1. Choisir une bonne position lors de la fixation du dossier [A] au mécanisme

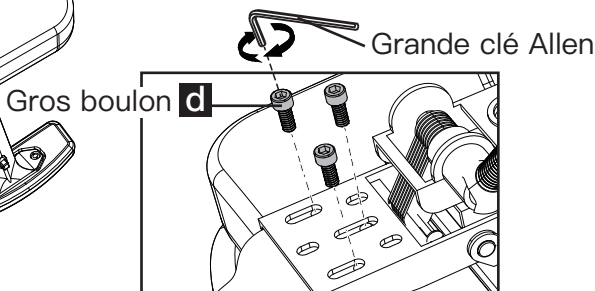
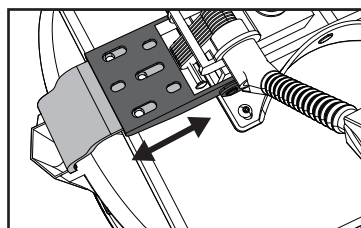
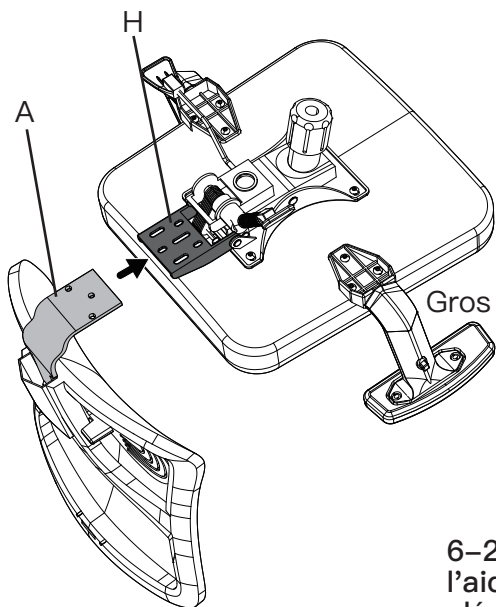

6-2. Fixer le dossier [A] au siège, à l'aide, de 3 gros boulons [d] et d'une clé Allen.

7

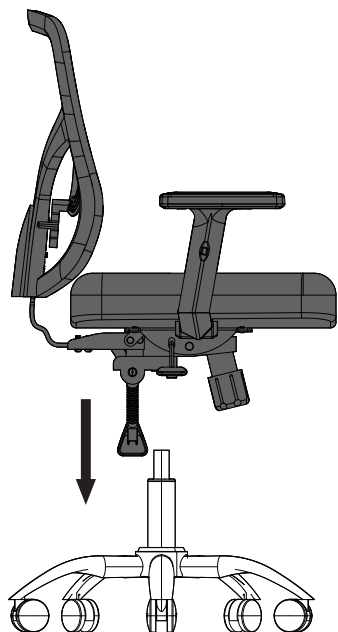

Aligner le trou du mécanisme sur le cylindre de levage pneumatique, puis appuyer sur le mécanisme pour le fixer audit cylindre.

8 Connecter l'appui-tête au dos, à l'aide des 2 boulons longs.

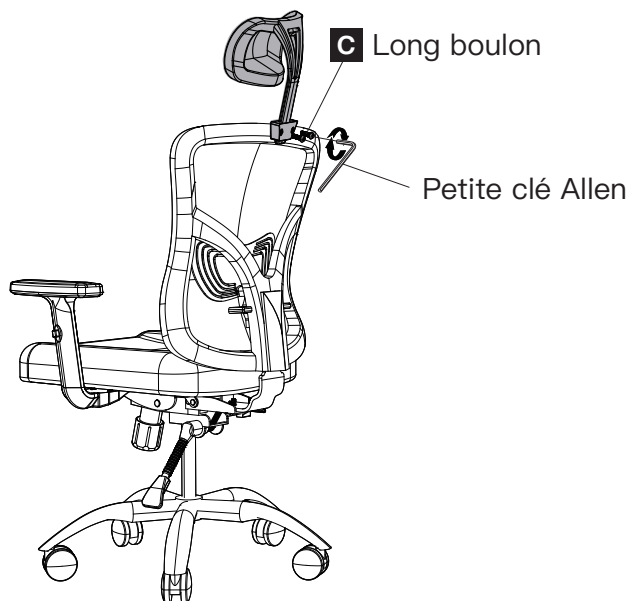

# Características

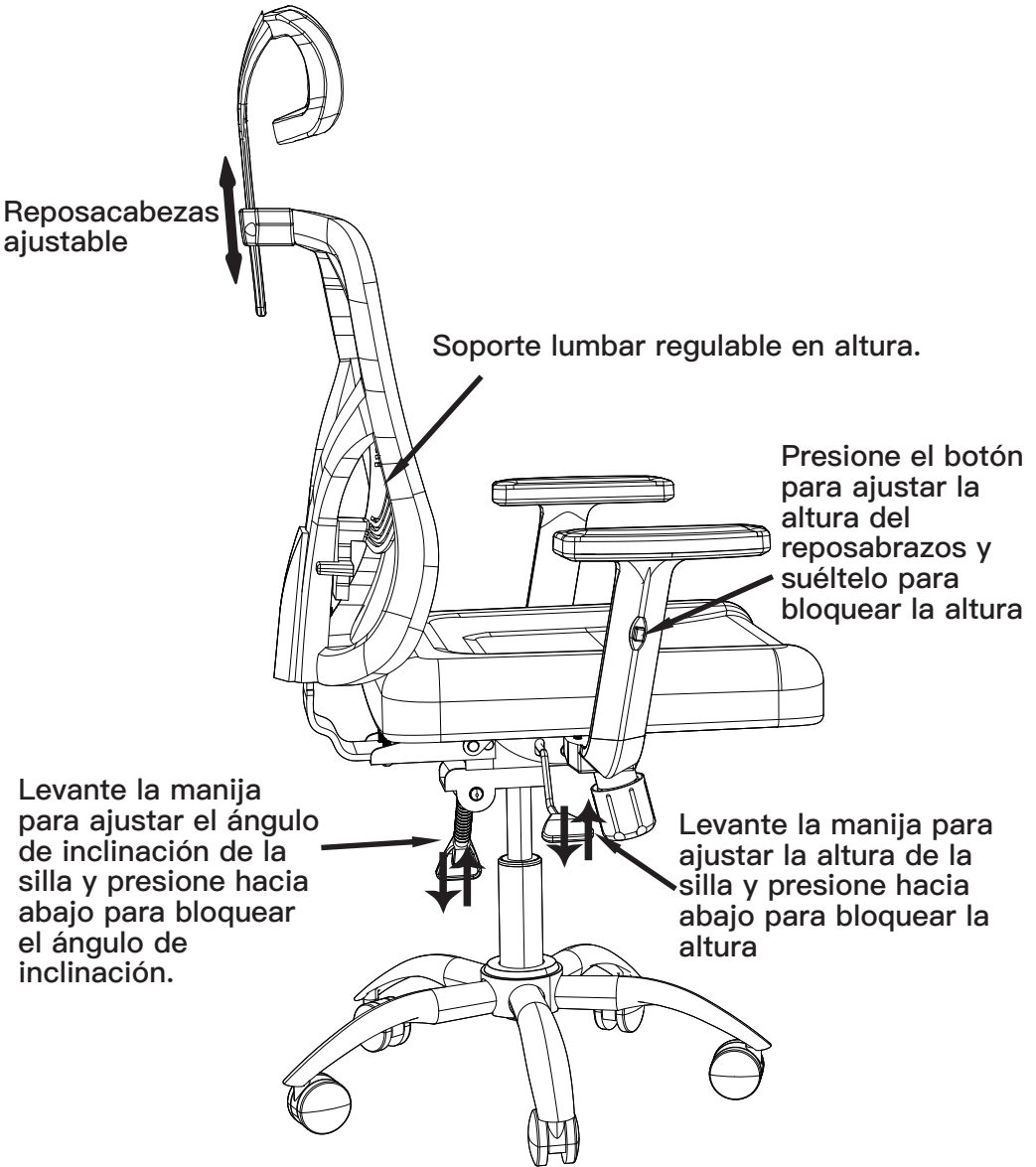

## INFORMACION DE SEGURIDAD IMPORTANTE

- Verifique el contenido del paquete con las piezas suministradas y la lista de hardware para asegurarse de que todos los componentes se hayan recibido sin daños. No use piezas dañadas o defectuosas.
- Lea atentamente todas las instrucciones antes de intentar la instalación.
- Una silla se limita a una persona.
- Coloque la silla sobre una superficie plana cuando la use.
- No permita que los niños menores de 5 años se sienten solos en la silla.
- No se siente en el reposabrazos, ya que podría dañar la silla y provocar daños.
- No se pare en la silla y la use como escalera o escalera.
- No coloque objetos pesados sobre la silla ni la use como carrito.
- Mantenga sus manos alejadas del mecanismo de la base del asiento además de la perilla para evitar lesiones no deseadas.
- No utilice artículos con filo o gancho para rayar la silla.
- Mantenga la silla alejada del fuego.
- No se coloque en la parte delantera del asiento para evitar que se caiga y siéntese completamente al final de la silla. Al pararse de la posición sentada, apriete los brazos de la silla.
- No levante las piernas mientras inclina el respaldo hacia atrás para evitar que se caiga.

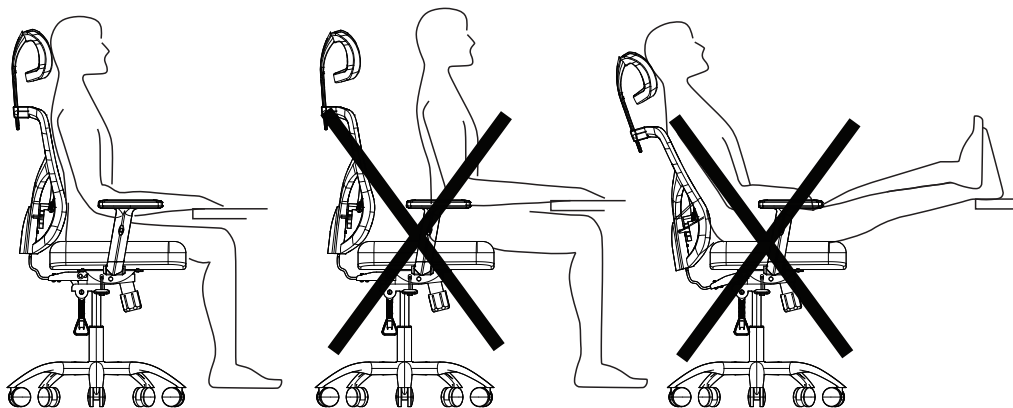

## Piezas suministradas

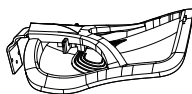

Espalda

A x1



Asiento

B x1

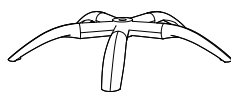

Pierna

C x1



Cubierta de la pierna

D x1



## Pasos de instalación

1

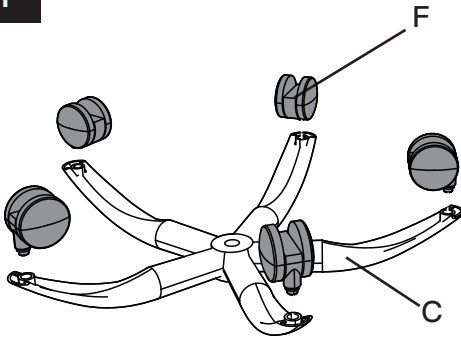

Gire y presione las 5 ruedas con fuerza en los 5 orificios de la pata.

2

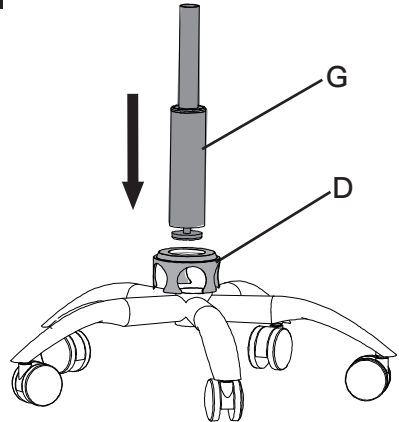

Presione la cubierta de la pierna y el cilindro de elevación de gas en la pierna.

3

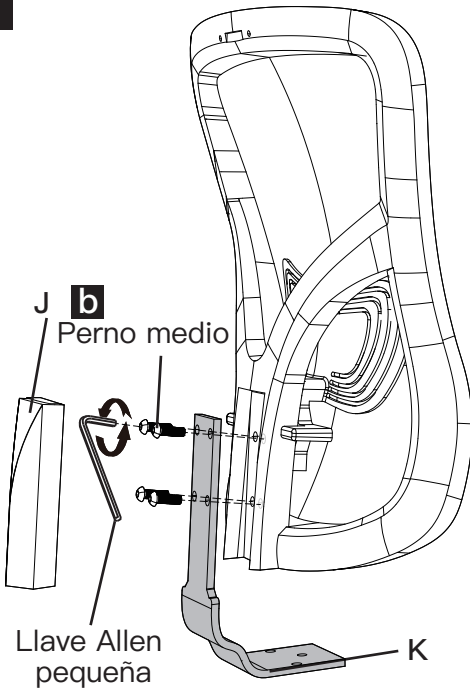

Asegure el soporte trasero a la parte posterior con 4 pernos centrales [b], luego coloque el plástico.

4

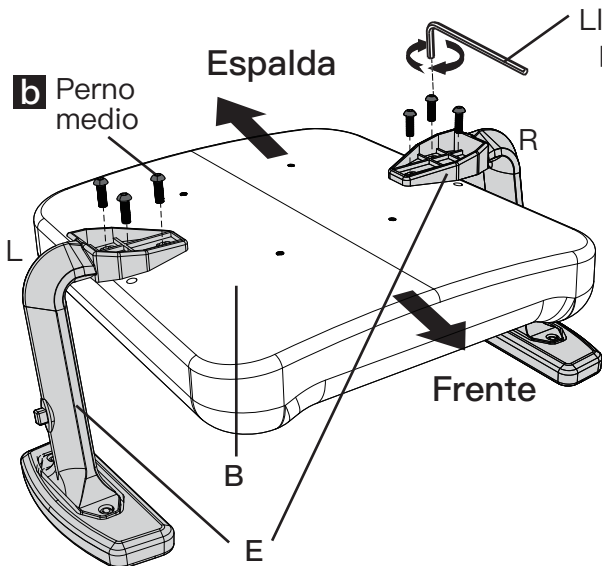

Conecte los reposabrazos al asiento con 6 tornillos intermedios [b] y una llave Allen pequeña.

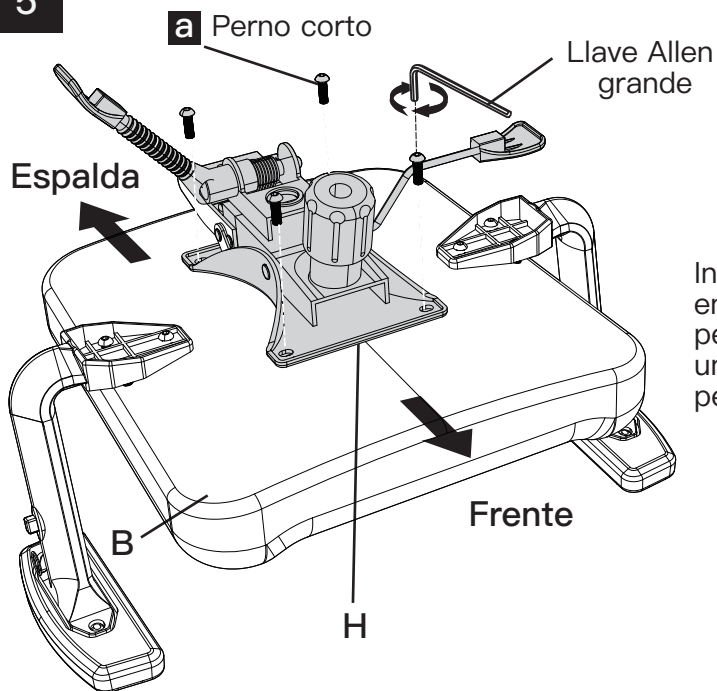
**5**

Instale el mecanismo en el asiento con 4 pernos cortos [a] y una llave Allen pequeña.

**6** 6-1. Elija la posición adecuada cuando coloque la parte posterior [A] en el mecanismo

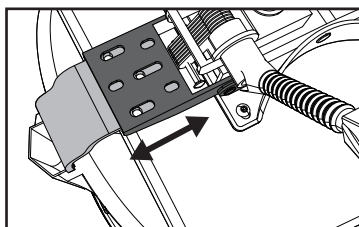
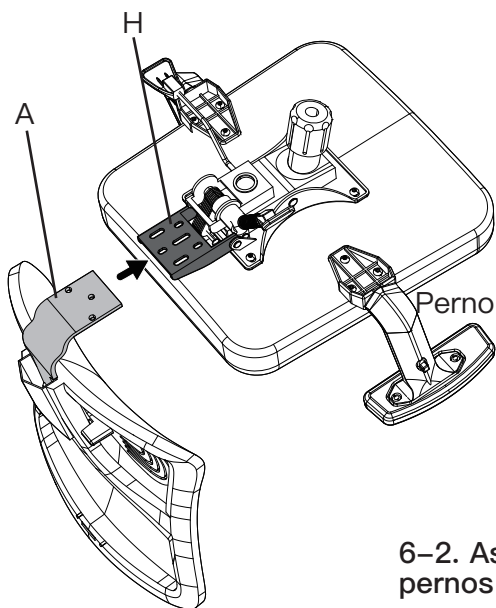

Llave Allen grande

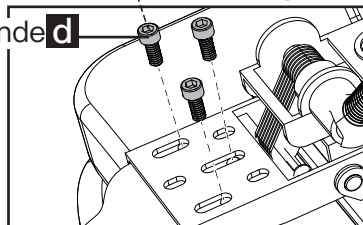

6-2. Asegure el respaldo [A] con 3 pernos grandes [d] y llave Allen.

7

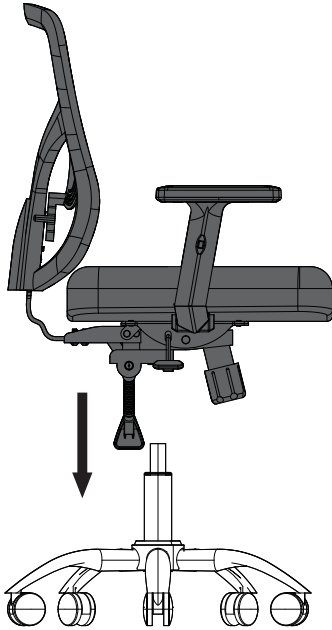

Alinee el orificio del mecanismo con el cilindro de elevación de gas, luego presione el mecanismo hacia abajo para asegurarlo al cilindro de elevación de gas.

8 Conecte el reposacabezas a la espalda con 2 pernos largos.



## Caratteristiche

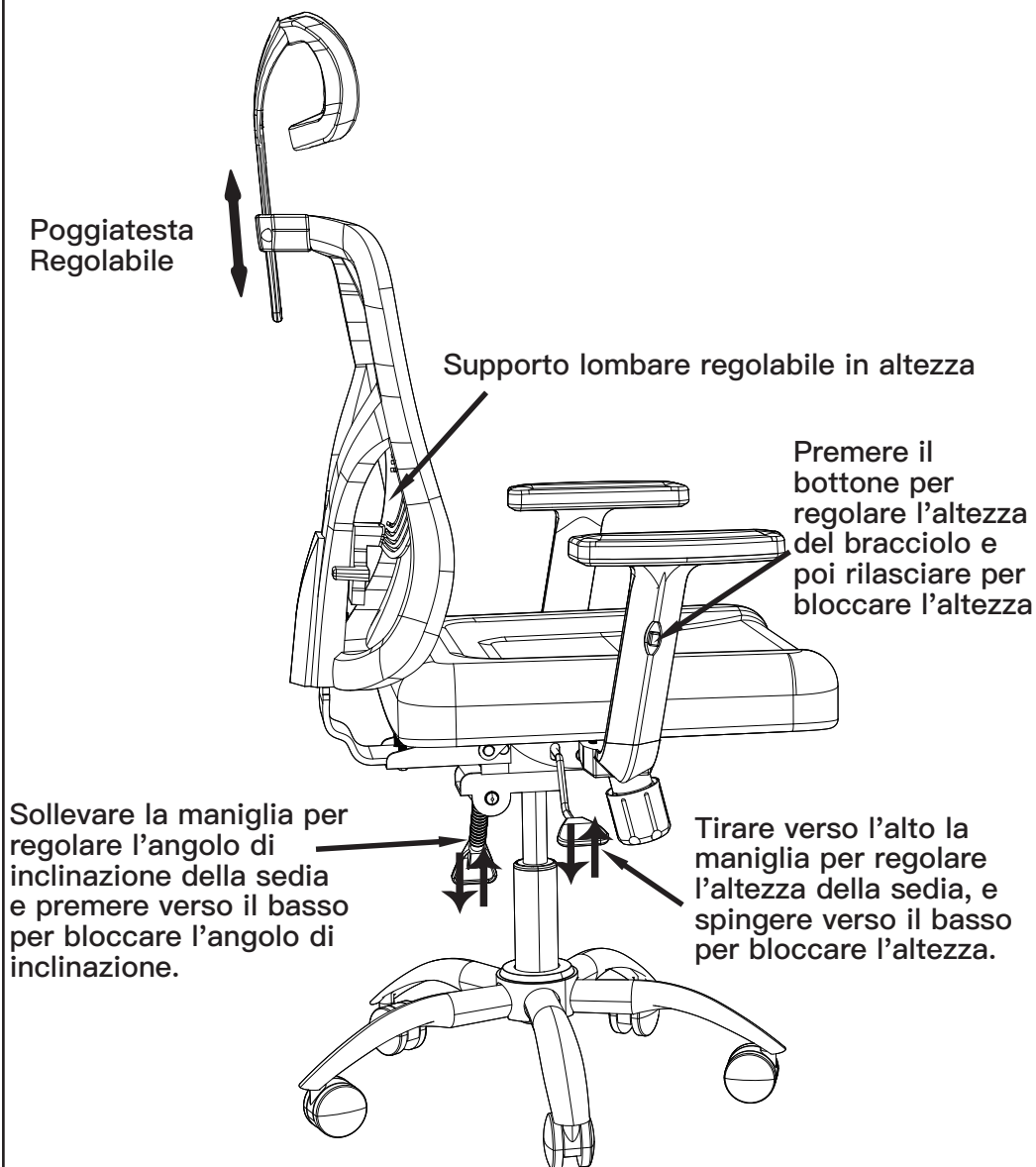

## IMPORTANTI INFORMAZIONI SULLA SICUREZZA

- Controllare il contenuto del pacchetto contro l'elenco delle parti e hardware forniti per assicurarsi che tutti i componenti sono stati ricevuti integri. Non utilizzare parti danneggiate o difettose.
- Leggere attentamente tutte le istruzioni prima di tentare l'installazione.
- Una sedia è limitata a una persona.
- Si prega di posizionare la sedia su una superficie piana durante l'utilizzo.
- Si prega di non lasciare i bambini di età inferiore a 5 anni sedersi da soli sulla sedia.
- Si prega di non sedersi sul bracciolo, che potrebbe causare danni alla sedia e causare pericolo.
- Non salire sulla sedia e usarla come una scala.
- Non appoggiare oggetti pesanti sulla sedia o utilizzarla come carrello.
- Tenere le mani lontane dal meccanismo della base del sedile oltre alla manopola per evitare lesioni indesiderate.
- Non usare oggetti taglienti o con uncini per graffiare la sedia
- Tenere la sedia lontana dal fuoco.
- Si prega di non sedersi sulla parte anteriore del sedile per evitare di scivolare o cadere, ma sedersi completamente sul sedile dalla parte anteriore. Quando si alza dalla sedia, si appoggia le mani sui braccioli della sedia come sostegno.
- Si prega di non sollevarsi le gambe mentre si inclina lo schienale all'indietro per evitare il ribaltare.

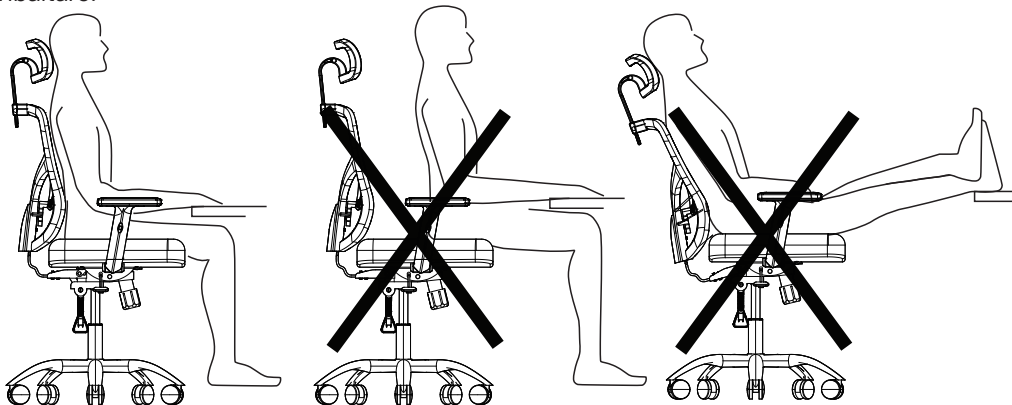

## Parti Fornite

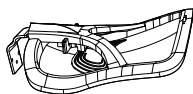

Schienale

A x1

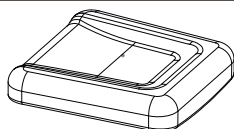

Sedile

B x1

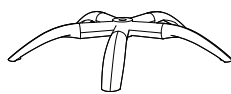

Gamba

C x1



Coprigamba

D x1

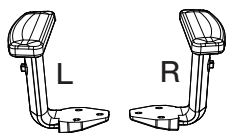

Bracciolo  
E x1



Ruota  
F x5

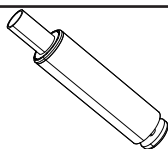

Pistone a gas  
G x1

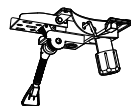

Meccanismo  
H x1

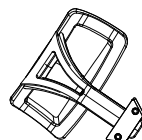

Poggiatesta  
I x1

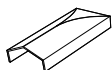

Coperchio di plastica  
J x1

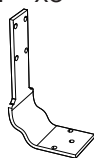

Paterazzo  
K x1



Bullone Corto  
a x4

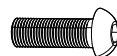

Bullone Medium  
b x10

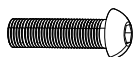

Bullone Lungo  
c x2



Bullone Grande  
d x3



Chiave a  
Brugola Piccola  
x1

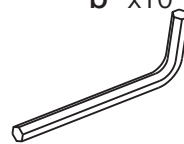

Chiave a  
Brugola Grande  
x1

## Passaggi di Installazione

1

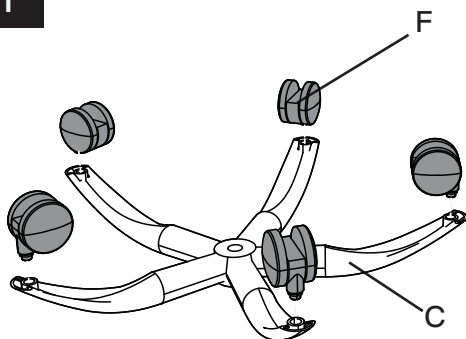

Ruotare e premere con forza le 5 ruote nei 5 fori sulla gamba.

2

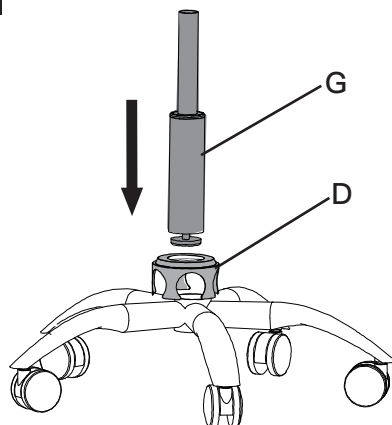

Spingere il coprigamba e il pistone a gas nella gamba.

3

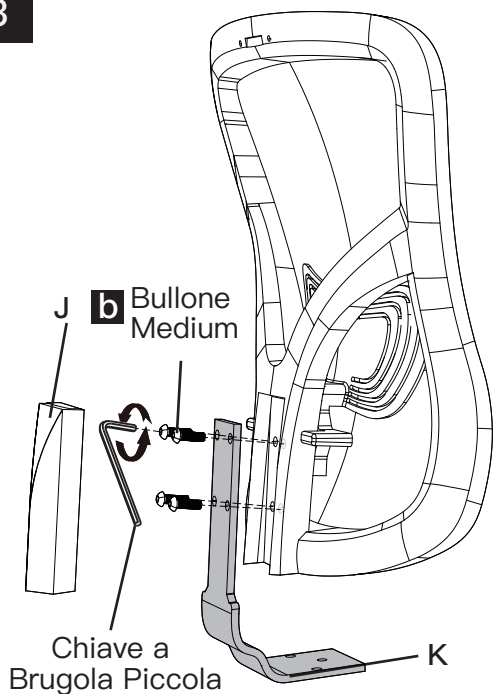

Fissare il supporto dello schienale allo schienale con 4 bulloni medium [b], quindi attaccare il pezzo di plastica.

4

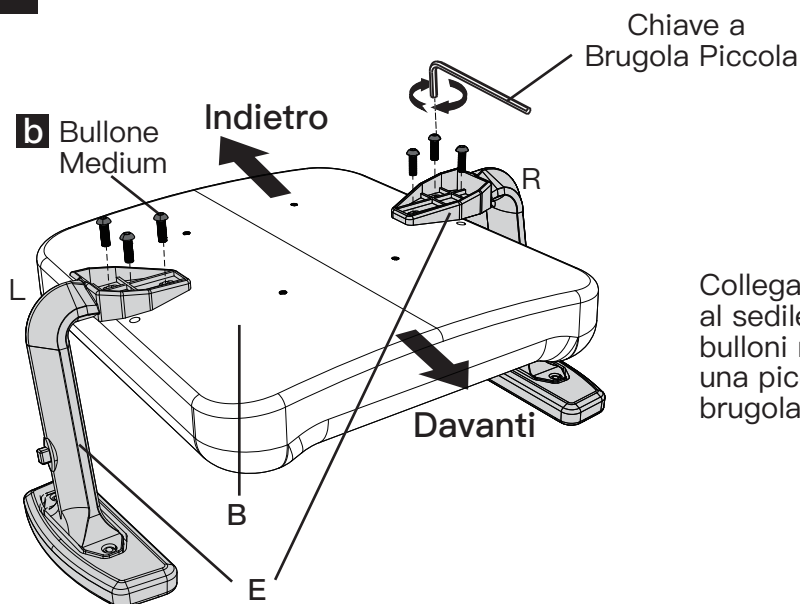

Collegare i braccioli al sedile con 6 bulloni medium [b] e una piccola chiave a brugola.

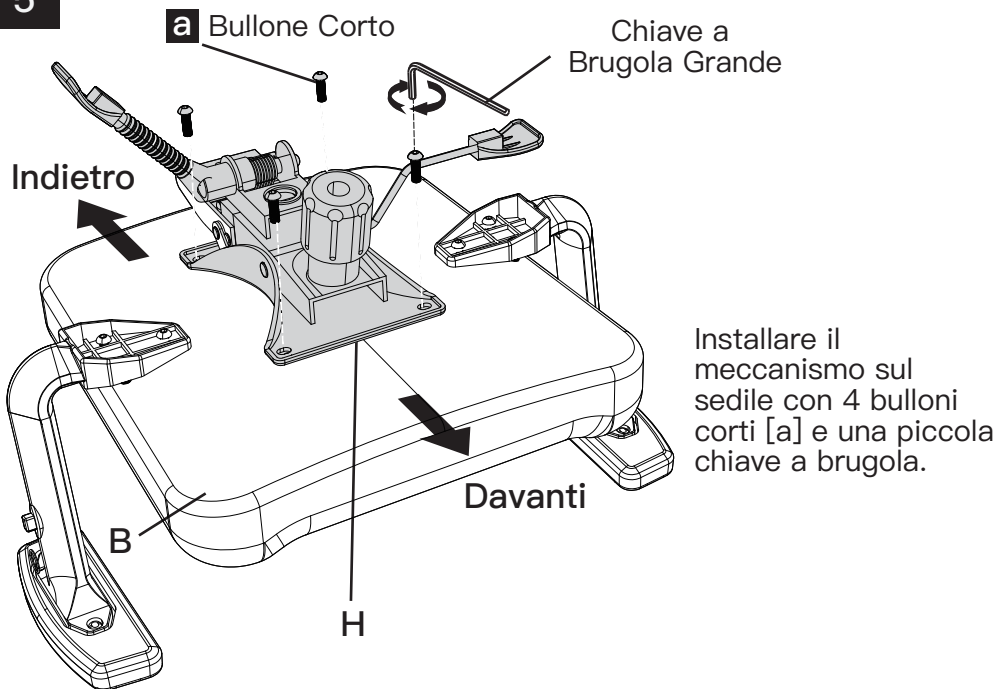
**5**

**6** 6-1. Scegliere la posizione corretta quando si fissa lo schienale [A] al meccanismo

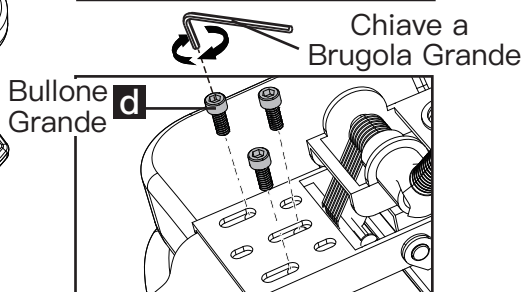
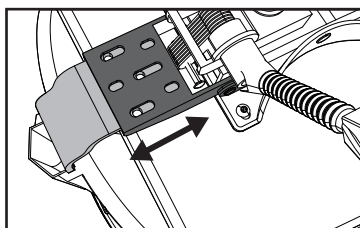
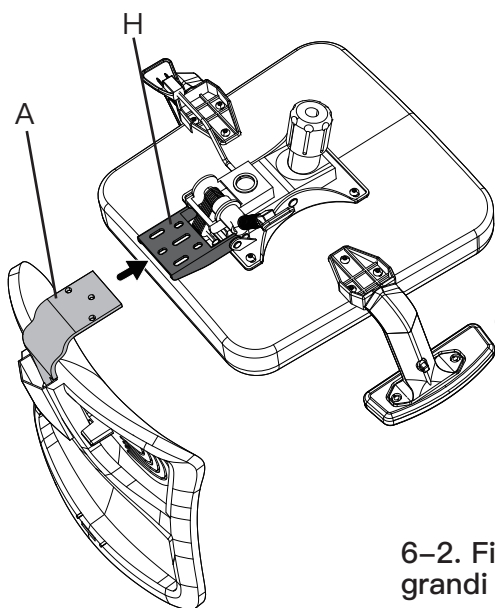

6-2. Fissare lo schienale [A] con 3 bulloni grandi [d] e una chiave a brugola.

7

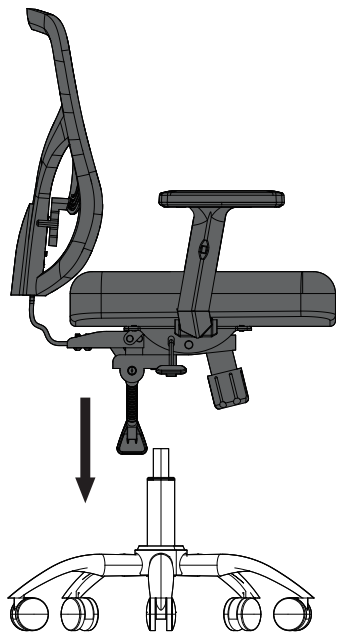

Allineare il foro sul meccanismo con il pistone a gas, quindi spingere il meccanismo verso il basso per fissarlo al pistone a gas.

8 Fissare il poggiatesta allo schienale con 2 bulloni lunghi.



# Thank you for choosing us!

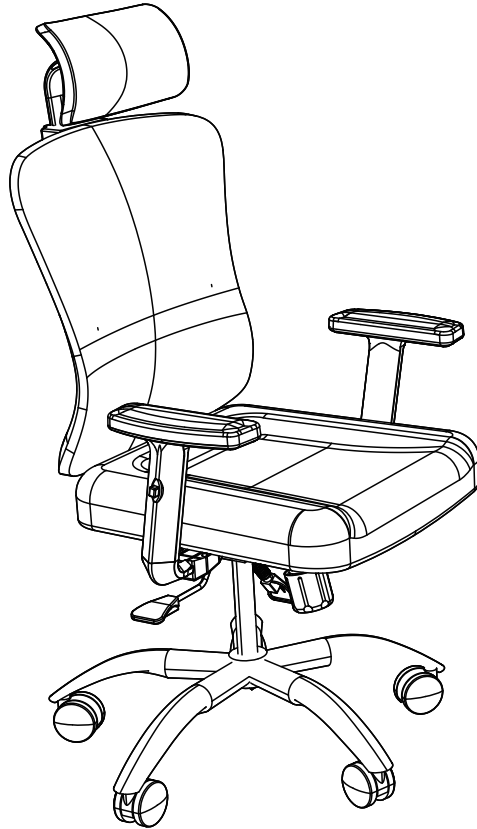

We do appreciate your product purchase. We hope that you are as happy with your product as we are designing and manufacturing it for you. We strive to provide you with the best quality products and services in the industry.