

# ASSEMBLY INSTRUCTIONS

## INSTRUCTIONS DE MONTAGE

### DINING TABLE

#### TABLE À MANGER

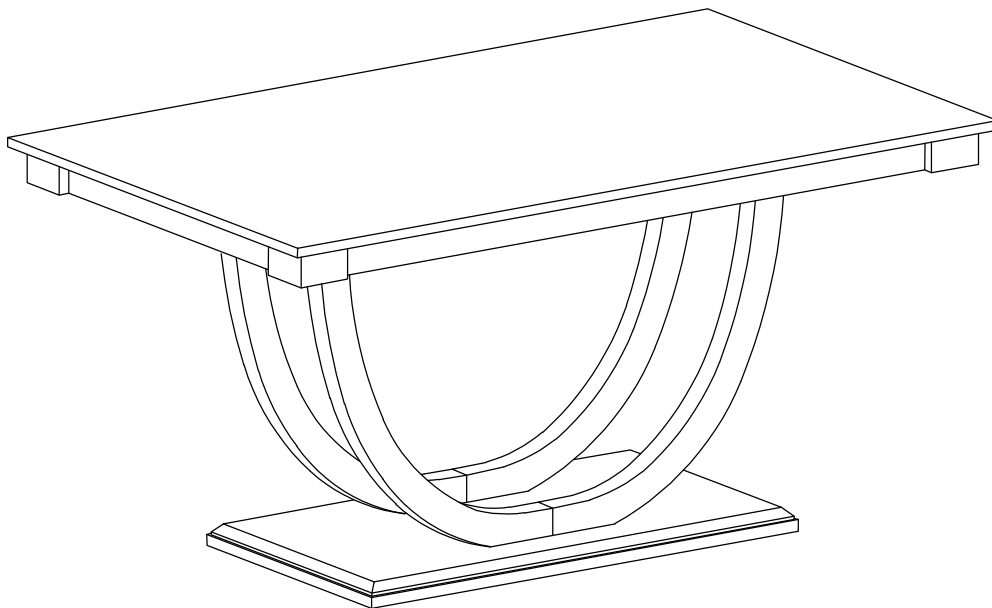

#### **IMPORTANT NOTE:**

#### **NOTE IMPORTANTE:**

- **PLACE ALL PARTS ON A CLEAN AND SMOOTH SURFACE SUCH AS A RUG OR CARPET TO AVOID THE PARTS FROM BEING SCRATCHED**  
PLACER TOUTES LES PIÈCES SUR UNE SURFACE PROPRE ET LISSE COMME UN TAPIS OU UNE MOQUETTE POUR ÉVITER QUE LES PIÈCES NE SOIENT RAYÉES.
- **BEFORE YOU BEGIN, KINDLY FOLLOW THE ASSEMBLY INSTRUCTIONS STEP BY STEP.**  
AVANT DE COMMENCER, VEUILLEZ SUIVRE LES INSTRUCTIONS D'ASSEMBLAGE ÉTAPE PAR ÉTAPE.
- **DO NOT TIGHTEN ALL SCREWS AND BOLTS UNTIL THE TABLE IS FULLY SET-UP.**  
NE SERREZ PAS TOUS LES VIS ET BOULONS TANT QUE LA TABLE N'EST PAS COMPLÈTEMENT INSTALLÉ.

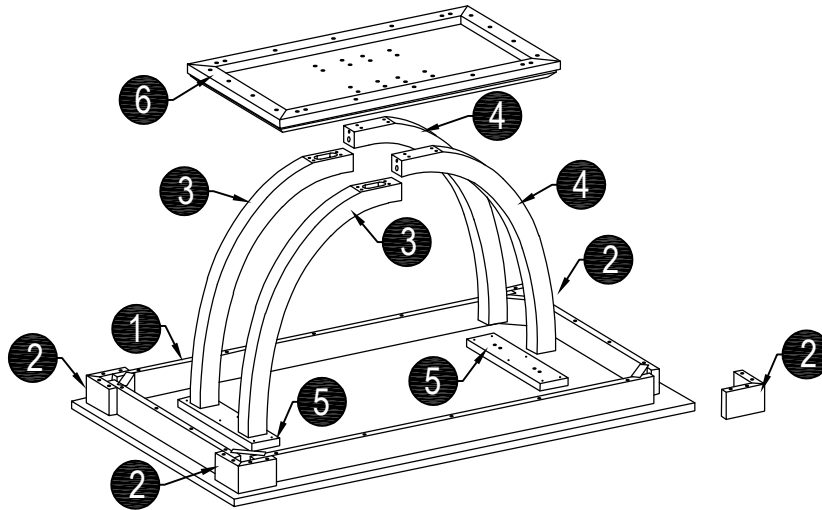

**CARTON CONTENT :**  
**CONENU DU CARTON**

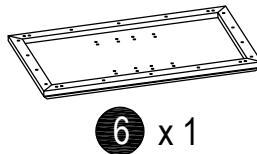
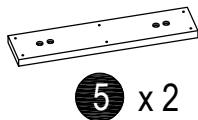
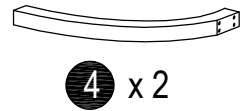
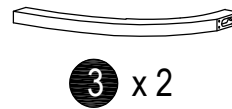
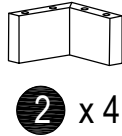
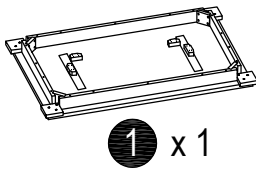

**TABLE PART LISTS**

LISTES DE PIÈCES DU TABLEAU

NO. NO.	DESCRIPTION	SKETCH DESSIN	QTY QTÉ
1	TABLE TOP DESSUS DE TABLE		1 PC
2	APRON DECO TABLIER DÉCO		4 PCS
3	TABLE LEG (L) PIED DE TABLE L		2 PCS
4	TABLE LEG (R) PIED DE TABLE R		2 PCS
5	LEG SUPPORT APPUI AUX JAMBES		2 PCS
6	LEG BOTTOM BAS DE JAMBE		1 PC

**TABLE HARDWARE LISTS**

LISTES DE MATÉRIEL DE TABLE

A	JCBC BOLT JCBC BOULON M6 x 45mm		24 PCS
B	JCBC BOLT JCBC BOULON M6 x 70mm		2 PCS
C	SPRING WASHER RONDELLE RESSORT 1/4"		26 PCS
D	FLAT WASHER RONDELLE PLATE 1/4"		26 PCS
E	WOOD DOWEL CHEVILLE EN BOIS M10 x 30mm		2 PCS
F	ALLEN KEY CLÉ ALLEN M4		1 PC
G	C/B SCREW VIS C/B M4 x 30mm		28 PCS
H	ADJUSTER AJUSTEUR M6 x 23mm		4 PCS

**ASSEMBLY INSTRUCTIONS**  
INSTRUCTIONS DE MONTAGE



# ASSEMBLY INSTRUCTIONS

## INSTRUCTIONS DE MONTAGE

### DINING CHAIR

#### CHAISES DE SALLE À MANGER

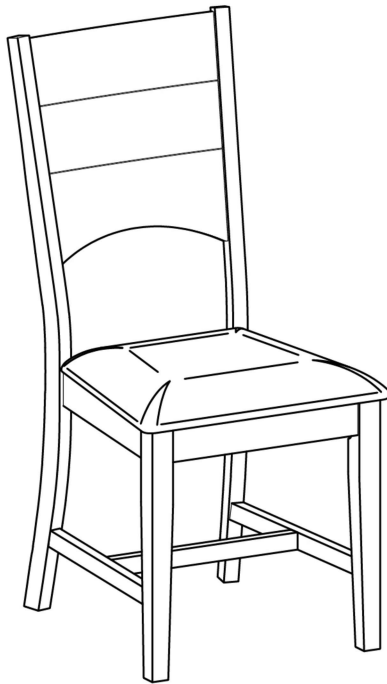

#### **IMPORTANT NOTE:**

#### **NOTE IMPORTANTE:**

- **PLACE ALL PARTS ON A CLEAN AND SMOOTH SURFACE SUCH AS A RUG OR CARPET TO AVOID THE PARTS FROM BEING SCRATCHED**  
PLACEZ TOUTES LES PIÈCES SUR UNE SURFACE PROPRE ET LISSE COMME UN TAPIS OU UNE MOQUETTE POUR ÉVITER QUE LES PIÈCES NE SOIENT RAYÉES.
- **BEFORE YOU BEGIN, KINDLY FOLLOW THE ASSEMBLY INSTRUCTIONS STEP BY STEP.**  
AVANT DE COMMENCER, VEUILLEZ SUIVRE LES INSTRUCTIONS D'ASSEMBLAGE ÉTAPE PAR ÉTAPE.
- **DO NOT TIGHTEN ALL SCREWS AND BOLTS UNTIL THE CHAIR IS FULLY SET-UP.**  
NE SERREZ PAS TOUS LES VIS ET BOULONS TANT QUE LA CHAISE N'EST PAS COMPLÈTEMENT INSTALLÉ.

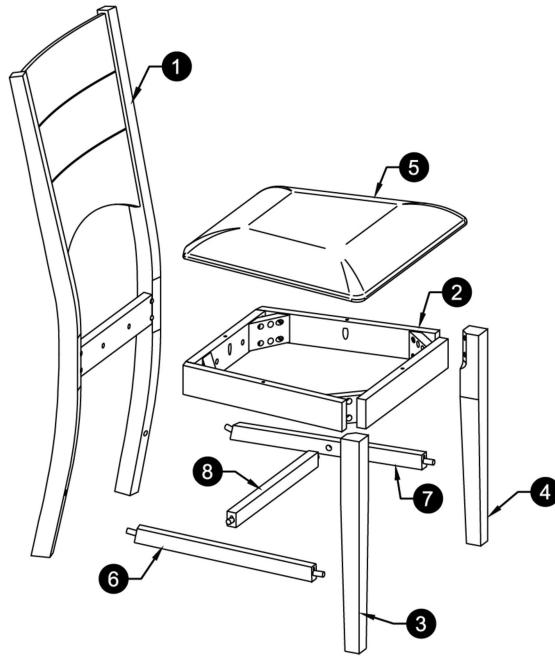

**CARTON CONTENT :**  
CONTENU DU CARTON

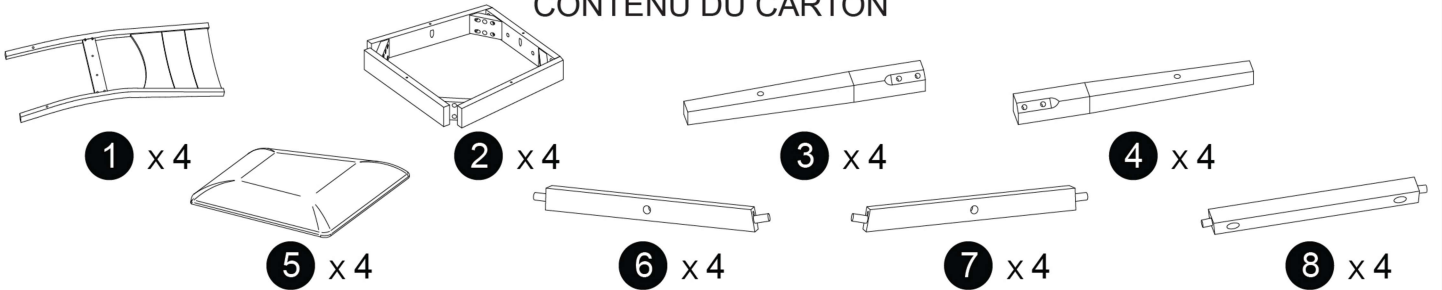

**CHAIR PART LISTS**

LISTES DE PIÈCES DE CHAISE

NO. NO.	DESCRIPTION DESCRIPTION	SKETCH DESSIN	QTY QTÉ
1	<b>BACK LEG</b> JAMBE ARRIÈRE		4 PCS
2	<b>BOX SEAT</b> SIÈGE BOÎTE		4 PCS
3	<b>FRONT LEG (L)</b> JAMBE AVANT (L)		4 PCS
4	<b>FRONT LEG (R)</b> JAMBE AVANT (R)		4 PCS
5	<b>SEAT</b> SIÈGE		4 PCS
6	<b>STRETCHER (L)</b> TENDEUR (L)		4 PCS
7	<b>STRETCHER (R)</b> TENDEUR (R)		4 PCS
8	<b>STRETCHER (M)</b> TENDEUR (M)		4 PCS

**CHAIR HARDWARE LISTS**

LISTES DE MATÉRIEL DE CHAISE

<b>A</b>	<b>JBCB BOLT</b> JCBC BOULON M6 x 35mm		8 PCS
<b>B</b>	<b>JBCB BOLT</b> JCBC BOULON M6 x 60mm		16 PCS
<b>C</b>	<b>JBCB BOLT</b> JCBC BOULON M6 x 80mm		16 PCS
<b>D</b>	<b>SPRING WASHER</b> RONDELLE RESSORT 1/4"		40 PCS
<b>E</b>	<b>FLAT WASHER</b> RONDELLE PLATE 1/4"		40 PCS
<b>F</b>	<b>ALLEN KEY</b> CLÉ ALLEN M4		1 PCS
<b>G</b>	<b>C/B SCREW</b> VIS C/B M4 x 30mm		24 PCS
<b>H</b>	<b>C/B SCREW</b> VIS C/B M4 x 45mm		16 PCS

**STEP 1**  
ETAPE 1

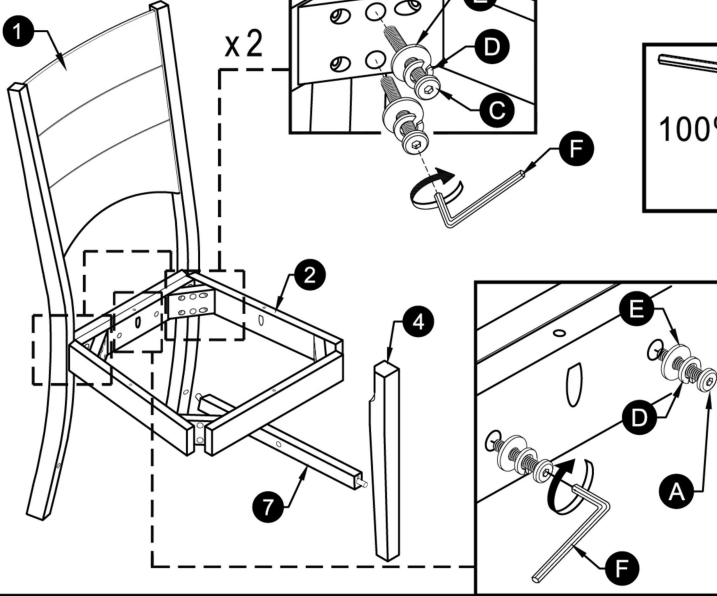

**STEP 2**  
ETAPE 2

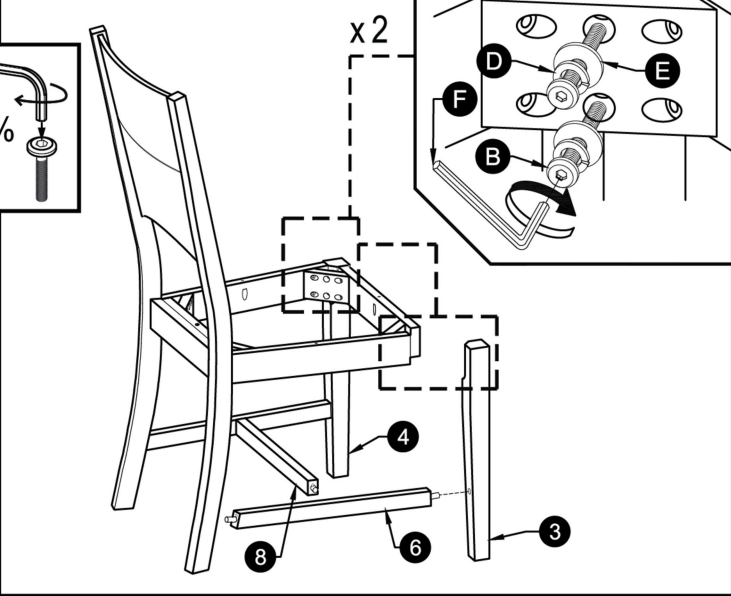

**STEP 3**  
ETAPE 3

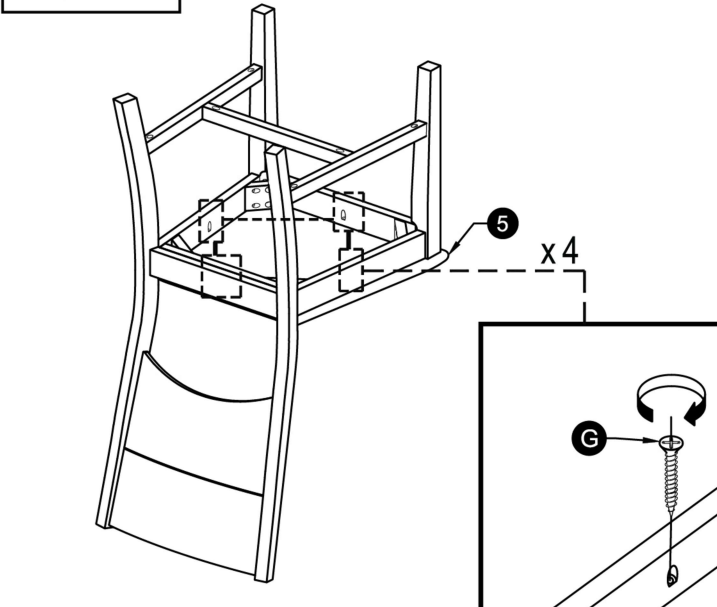

**STEP 4**  
ETAPE 4

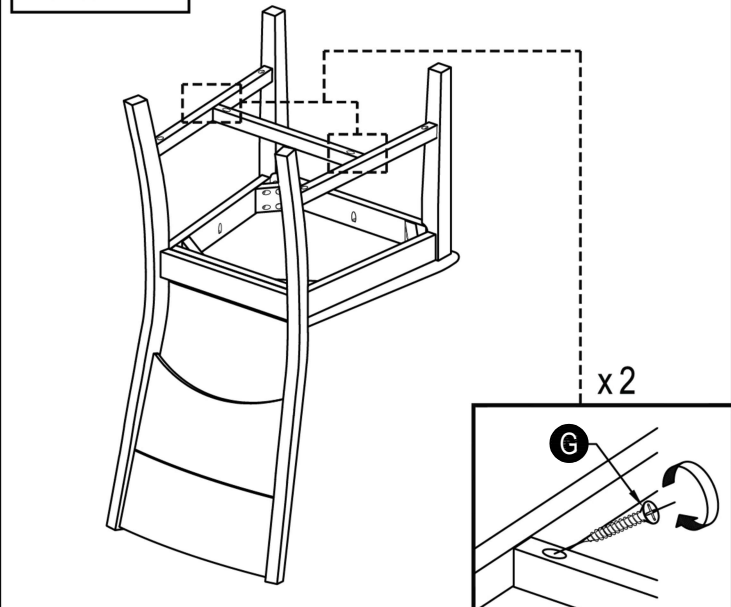

**STEP 5**  
ETAPE 5

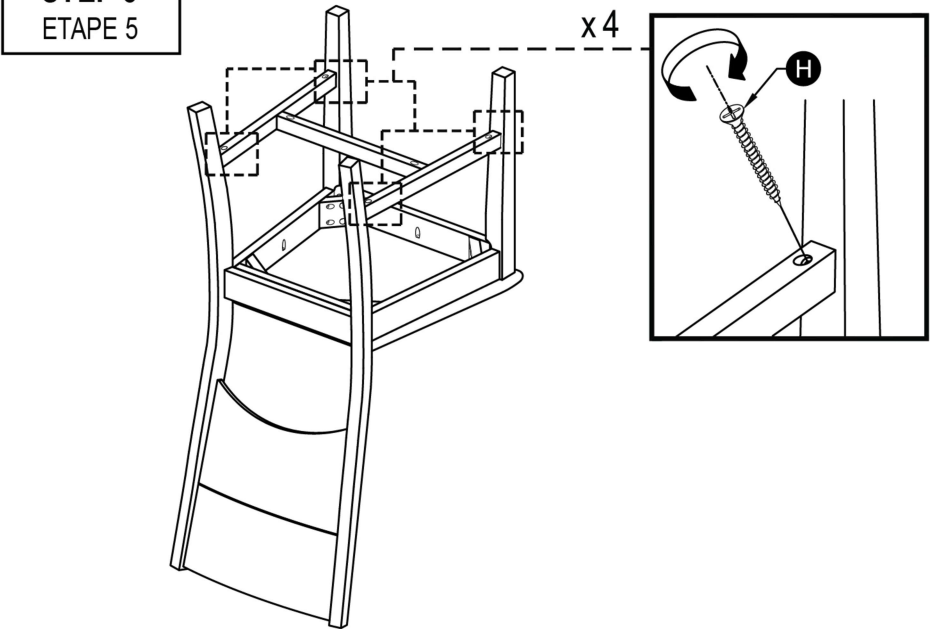

**ASSEMBLY  
COMPLETE !  
ASSEMBLAGE  
COMPLÉTÉ !**

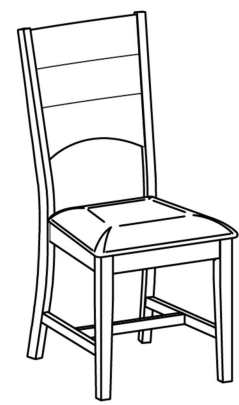

# ASSEMBLY INSTRUCTIONS

## INSTRUCTIONS DE MONTAGE

### DINING BENCH

#### BANC DE SMLLE À MANGER

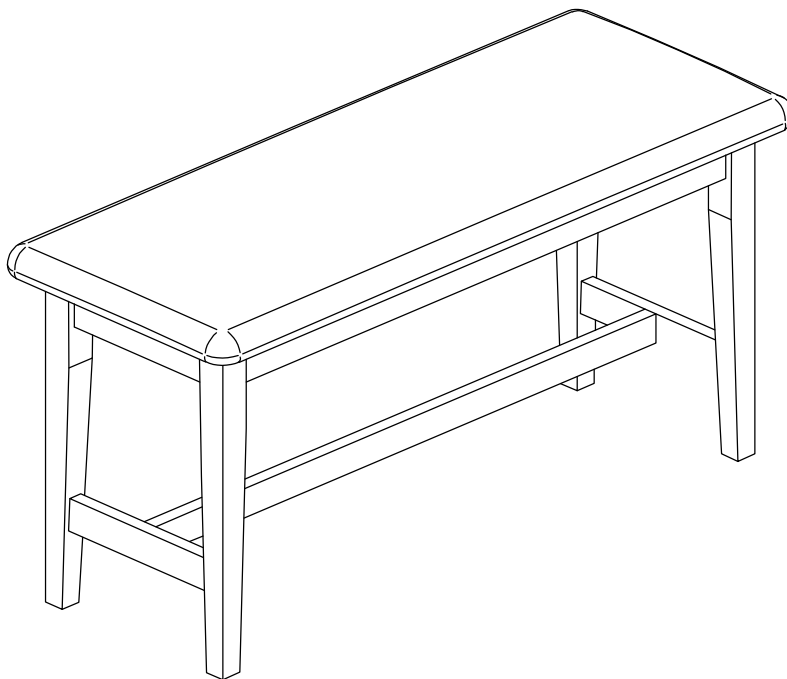

#### **IMPORTANT NOTE:**

#### **NOTE IMPORTANTE:**

- **PLACE ALL PARTS ON A CLEAN AND SMOOTH SURFACE SUCH AS A RUG OR CARPET TO AVOID THE PARTS FROM BEING SCRATCHED**  
PLACER TOUTES LES PIÈCES SUR UNE SURFACE PROPRE ET LISSE COMME UN TAPIS OU UNE MOQUETTE POUR ÉVITER QUE LES PIÈCES NE SOIENT RAYÉES.
- **BEFORE YOU BENSON, KINDLY FOLLOW THE ASSEMBLY INSTRUCTIONS STEP BY STEP.**  
AVANT DE COMMENCER, VEUILLEZ SUIVRE LES INSTRUCTIONS D'ASSEMBLAGE ÉTAPE PAR ÉTAPE.
- **DO NOT TIGHTEN ALL SCREWS AND BOLTS UNTIL THE BENCH IS FULLY SET-UP.**  
NE SERREZ PAS TOUS LES VIS ET BOULONS TANT QUE LA BANC N'EST PAS COMPLÈTEMENT INSTALLÉ.

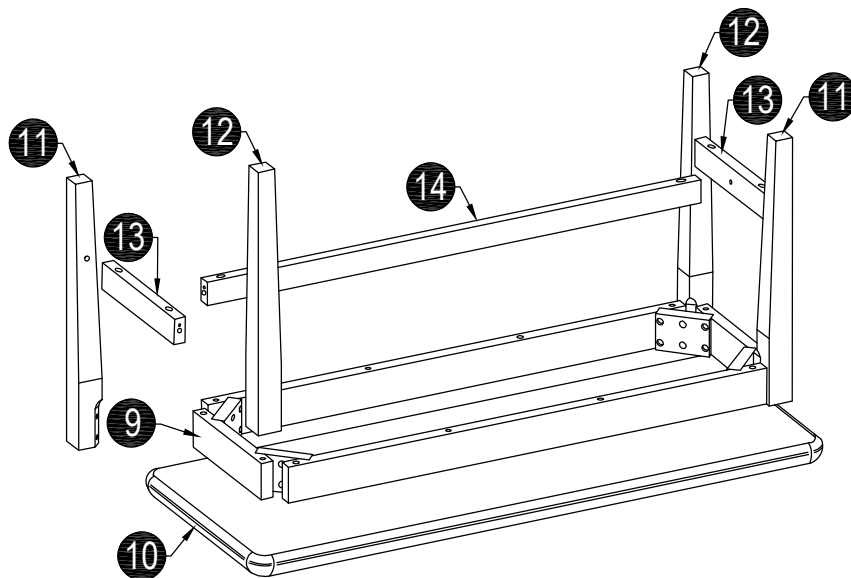

**CARTON CONTENT :**  
**CONENU DU CARTON**

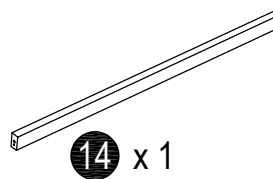
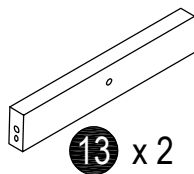
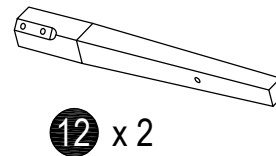
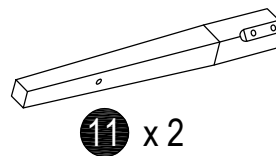
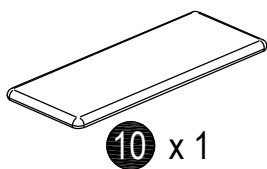
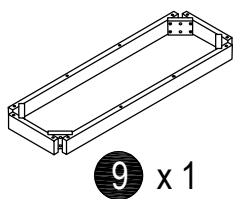

**BENCH PART LISTS**  
**LISTE DES PIECES DE BANC**

NO. NO.	DESCRIPTION DESCRIPTION	SKETCH DESSIN	QTY QTÉ
9	<b>BOX SEAT</b> SIÈGE BOÎTE		<b>1 PC</b>
10	<b>SEAT</b> SIÈGE		<b>1 PC</b>
11	<b>LEG (L)</b> JAMBE (L)		<b>2 PCS</b>
12	<b>LEG (R)</b> JAMBE (R)		<b>2 PCS</b>
13	<b>STRETCHER (S)</b> TENDEUR (S)		<b>2 PCS</b>
14	<b>STRETCHER (L)</b> TENDEUR (L)		<b>1 PC</b>

**BENCH HARDWARE LISTS**  
**LISTE DES MATERIEL DE BANC**

<b>I</b>	C/B SCREW VIS C/B M4 x 45mm		<b>4 PCS</b>
<b>J</b>	JCBC BOLT JCBC BOULON M6 x 70mm		<b>8 PCS</b>
<b>K</b>	SPRING WASHER RONDELLE RESSORT 1/4"		<b>8 PCS</b>
<b>L</b>	FLAT WASHER RONDELLE PLATE 1/4"		<b>8 PCS</b>
<b>M</b>	ALLEN KEY CLÉ ALLEN M4		<b>1 PC</b>
<b>N</b>	C/B SCREW VIS C/B M4 x 30mm		<b>14 PCS</b>
<b>O</b>	WOOD DOWEL CHEVILLE EN BOIS M8 x 30mm		<b>6 PCS</b>

**STEP 1**  
ETAPE 1

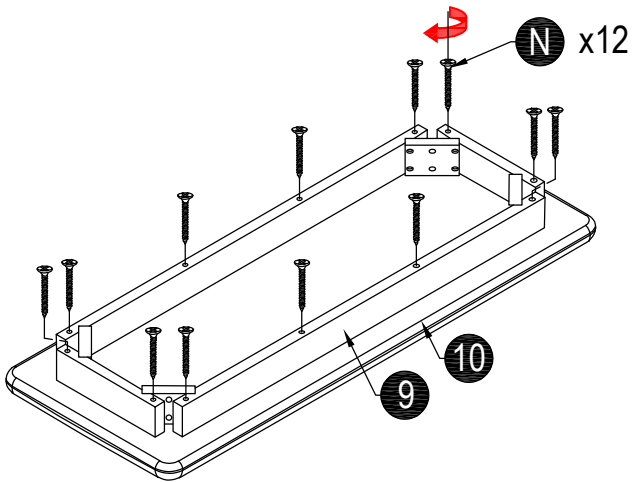

**STEP 2**  
ETAPE 2

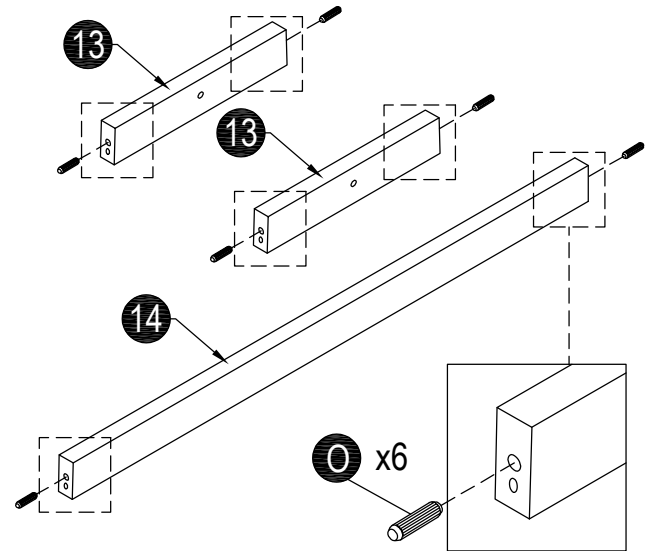

**STEP 3**  
ETAPE 3

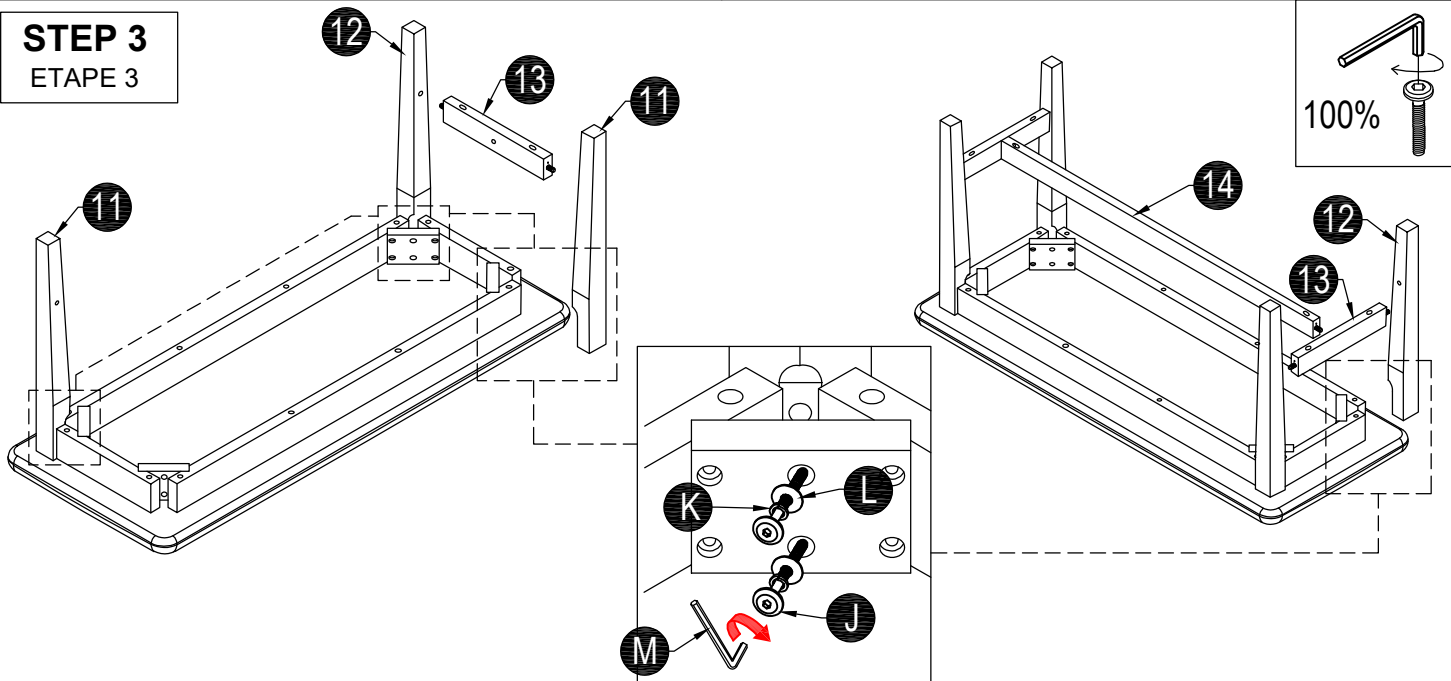

**STEP 4**  
ETAPE 4

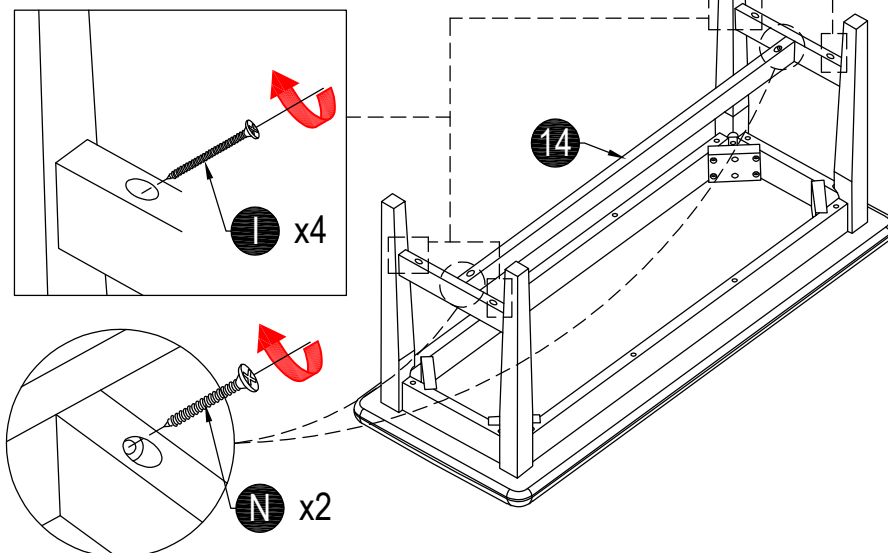

**ASSEMBLY  
COMPLETE !  
ASSEMBLAGE  
COMPLÉTÉ !**

