

Assembly Instructions

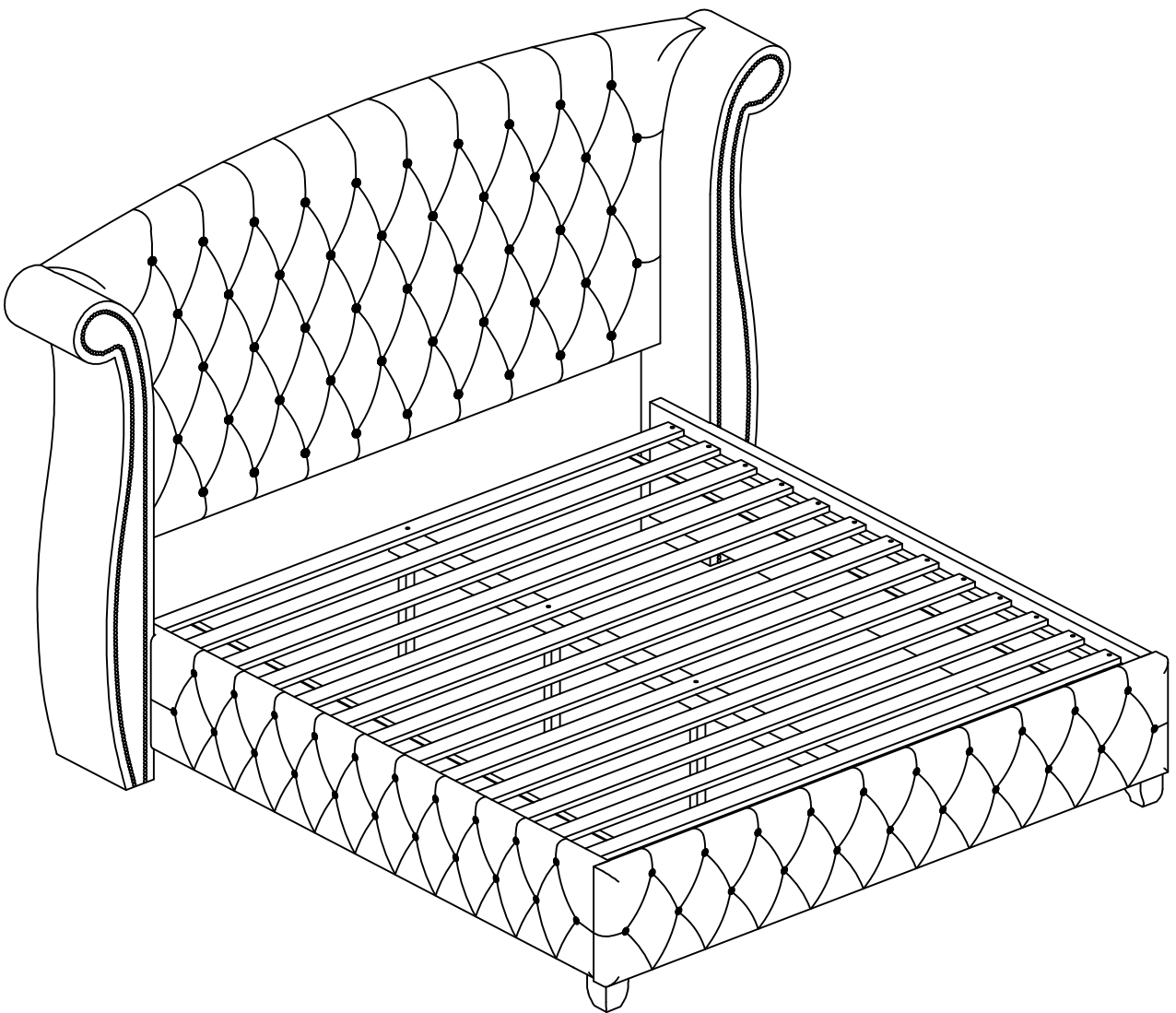





ITEM: F1979 KING BED



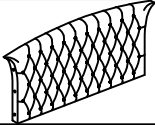

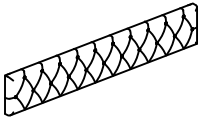
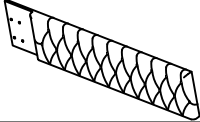

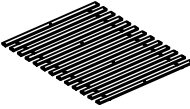
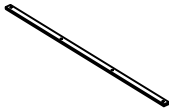









Assembly Instructions

ITEM: F1979 KING BED

PARTS LIST

NO	DECS	PHOTO	Q'TY
A	Upholstery headboard panel		1 pc
B	Upholstery headboard legs(L/R)		2 pcs
C	Upholstery footboard		1 pc
D	Upholstery side rail (L/R)		2 pcs
E	Footboard legs		2 pcs
F	Slat		1 set
G	Support rail		1 pc
H	Center support leg		4 pcs

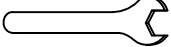
HARDWARE LIST

NO	DECS	PHOTO	Q'TY
1	Long Bolts Ø5/16" x 70mm		8 pcs
2	Long Bolts Ø5/16" x 60mm		6 pcs
3	Bolts Ø1/4" x 60mm		4 pcs
4	Bolts Ø5/16" x 100		2 pcs
5	Threaded Stud Ø5/16" x 90		4 pcs
6	Hex Nut Ø5/16"		4 pcs
7	Spring washer Ø5/16"		16 pcs
8	Flats washer Ø5/16"		16 pcs
9	Spring washer Ø1/4"		4 pcs
10	Flats washer Ø1/4"		4 pcs
11	Haft round Ø5/16"		4 pcs
12	Allen key 4mm		1 pc
13	Allen Wrench Ø12mm		1 pc
14	Screw Ø4 x 30mm		26 pcs

Assembly Instructions

ITEM: F1979 KING BED

Step 1

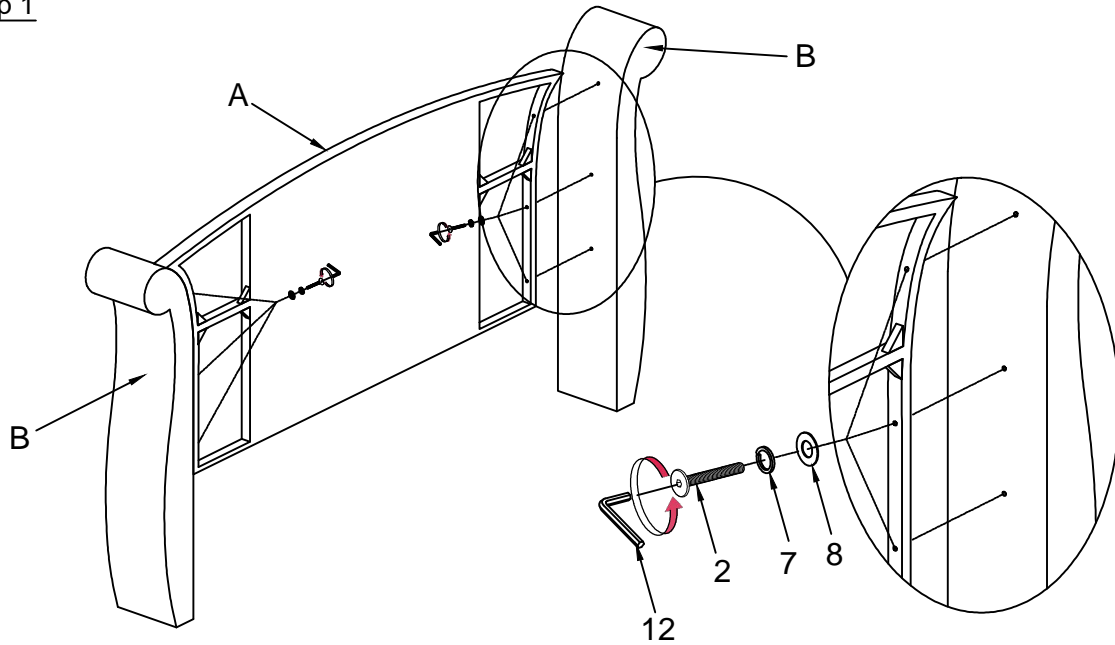

Step 2

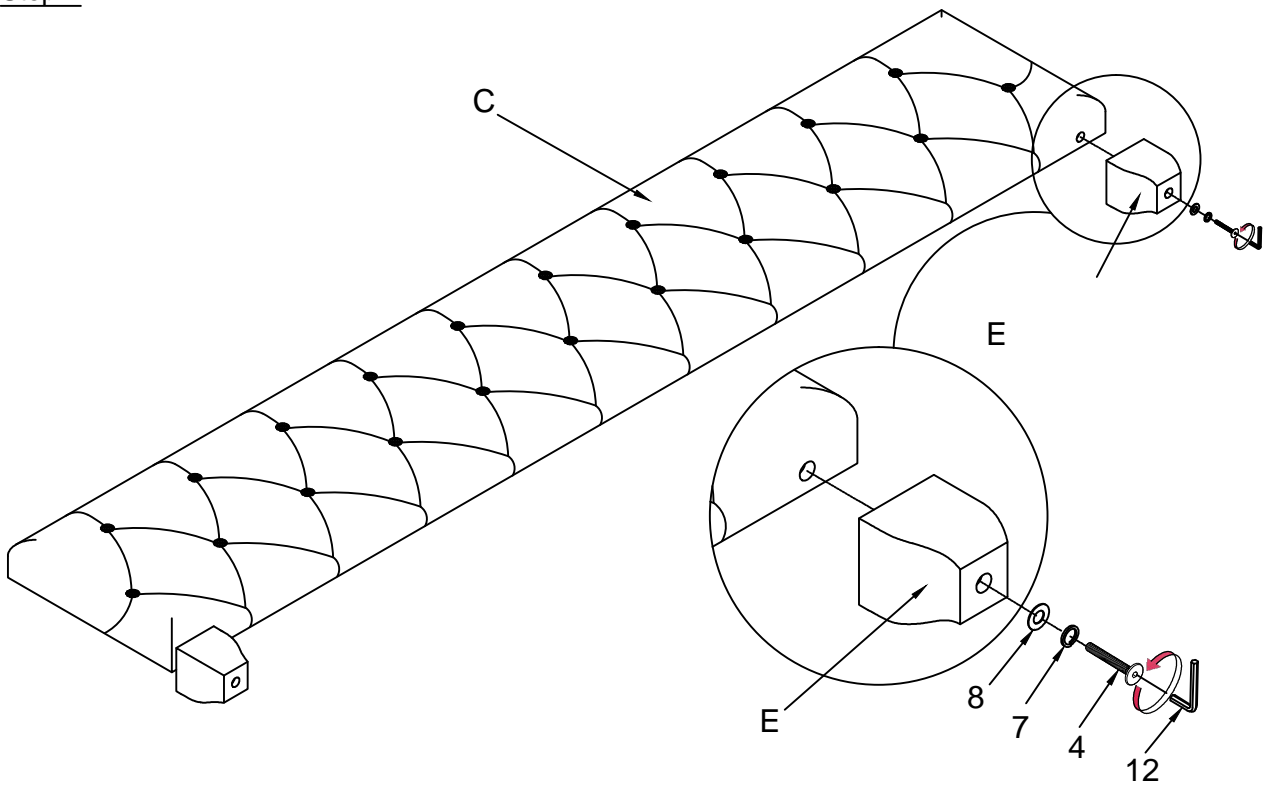

Assembly Instructions

ITEM: F1979 KING BED

Step 3

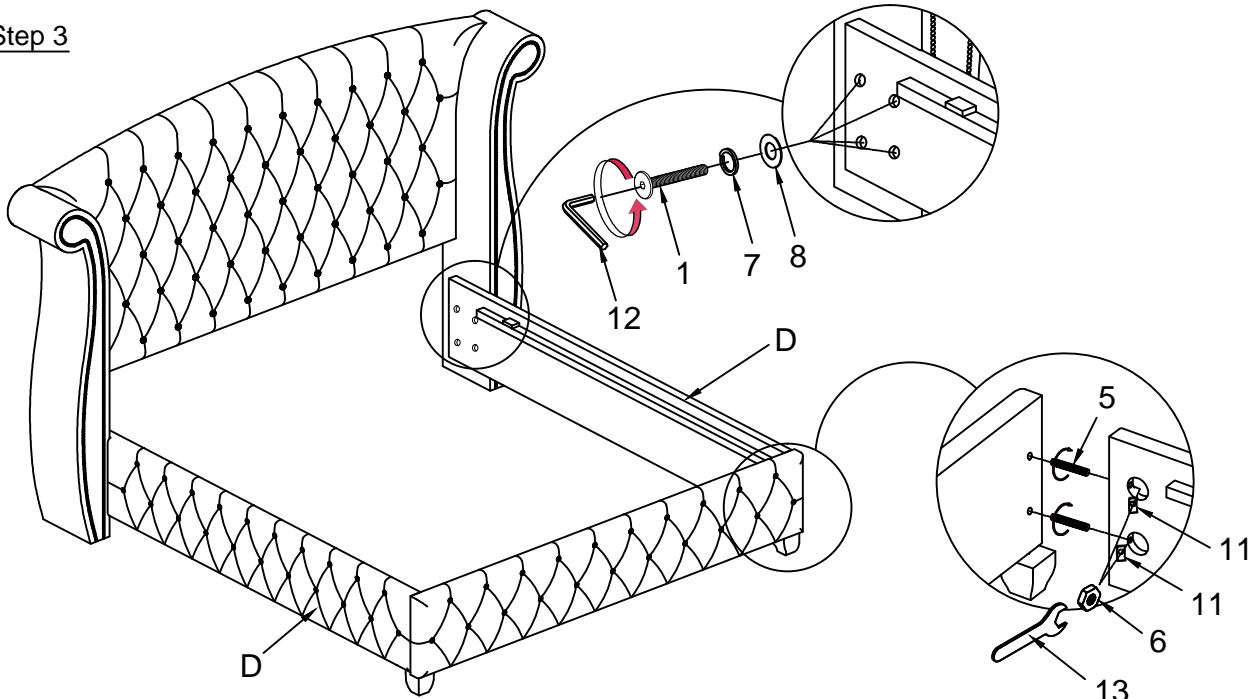

Step 4

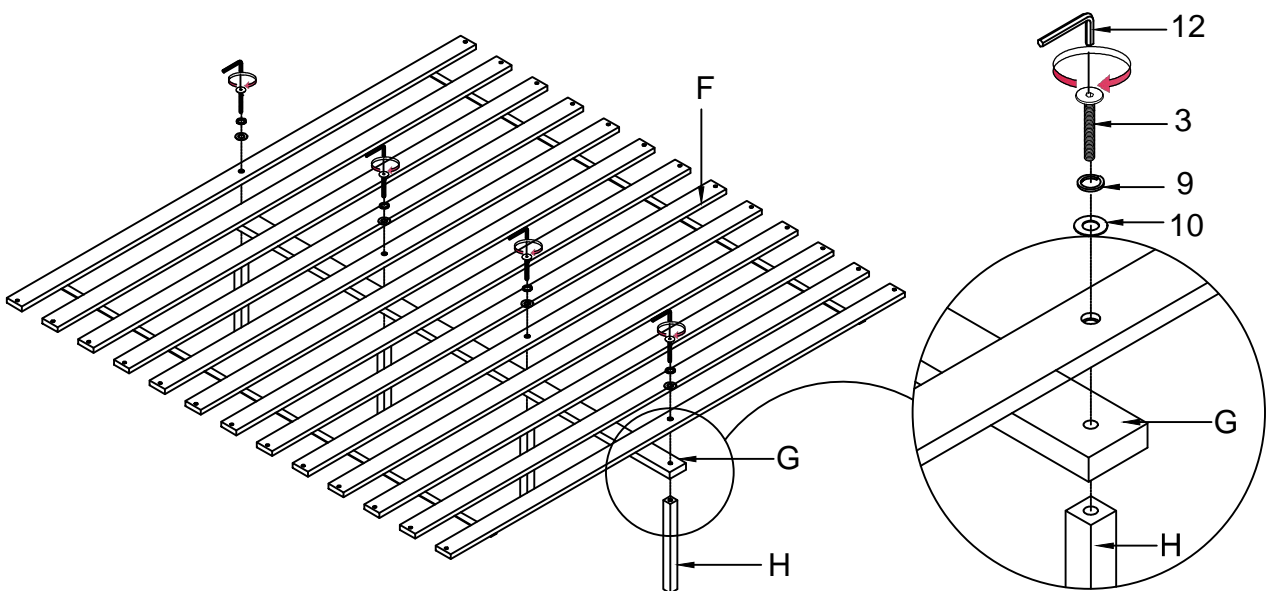

Assembly Instructions

ITEM: F1979 KING BED

Step 5

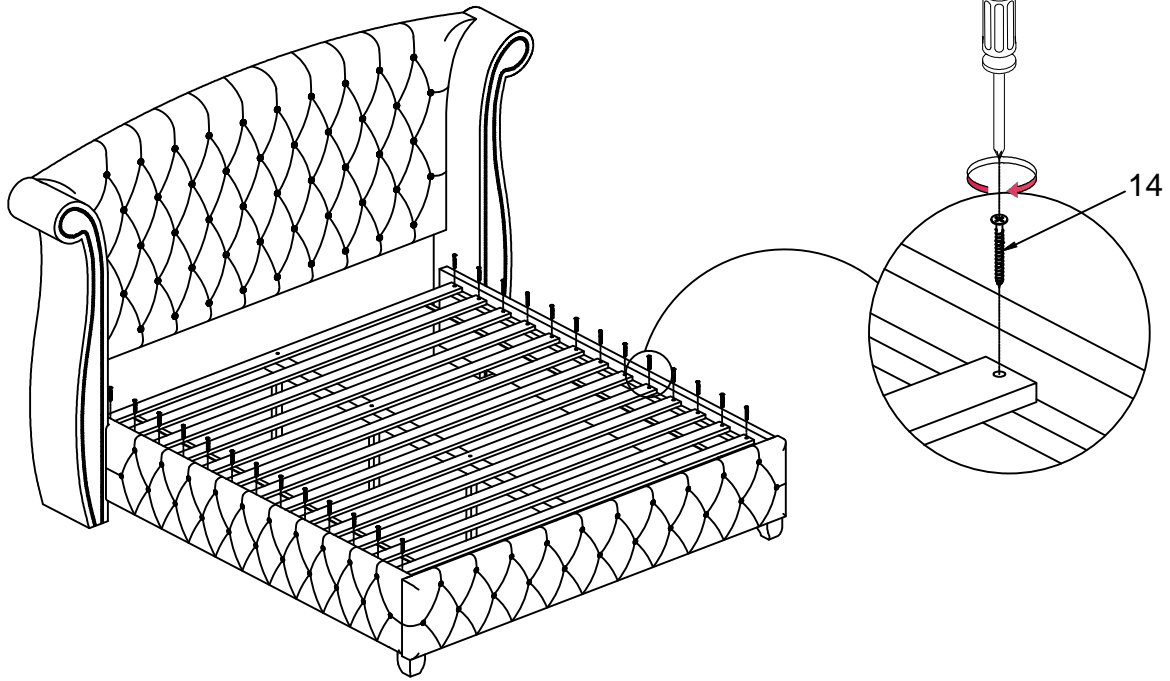

Completed

