

Required Tools : Screwdriver & Hammer

# MODEL : NEWTON (NIGHT STAND)

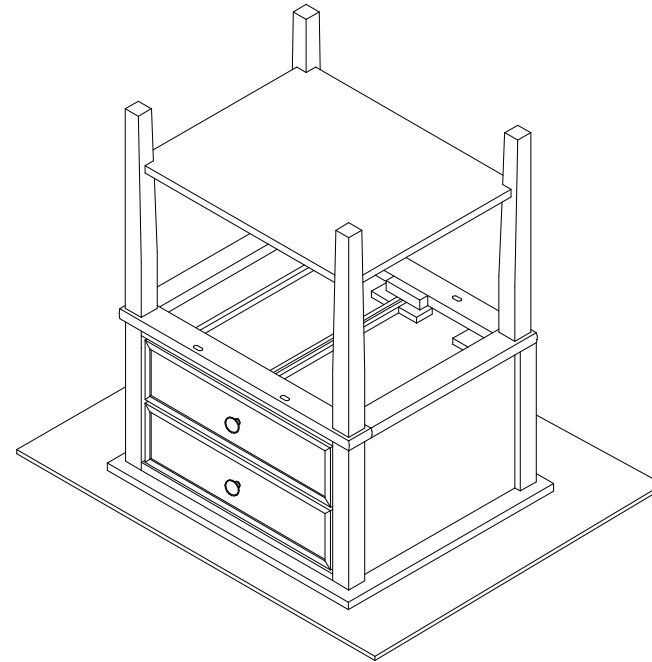

Please place on the carton while installing to prevent damage or scratches.

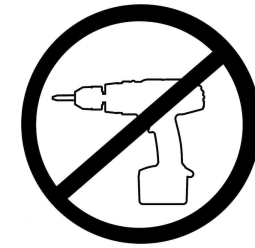
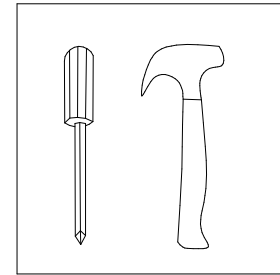
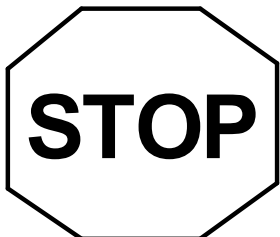

For missing parts/assembly questions call 201-565-6327

# ASSEMBLY INSTRUCTION ( PART & HARDWARE LIST )

## MODEL : NEWTON (NIGHT STAND)

1.

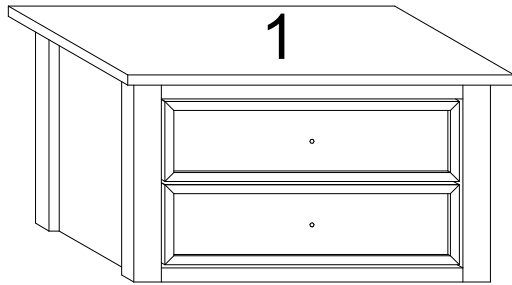

TOP NIGHT STAND

2.

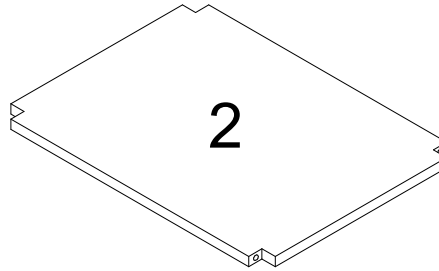

BOTTOM

3.

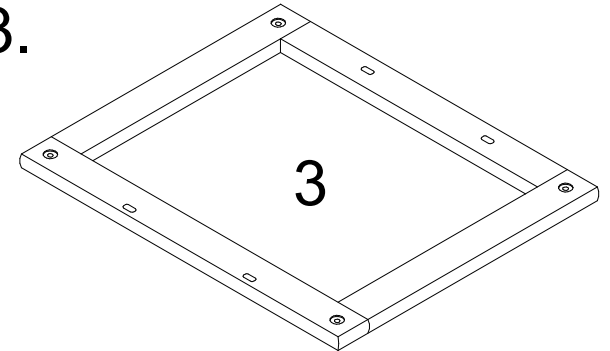

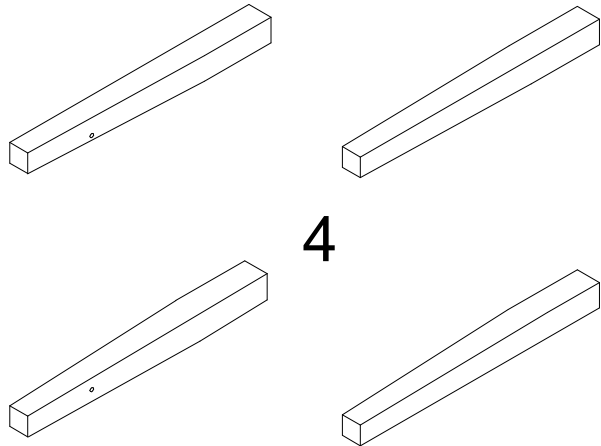

FRAME

4.



LEG (4PCS)

NO	HARDWARE DESCRIPTION	QTY
A.	Steel Handle 	2
B.	Handle Screw 	2
C.	JCBC Bolt M6 x 35mm 	4
D.	JCBC Bolt M6 x 50mm 	4
E.	Spring Washer 	8
F.	Flat Washer 	8
G.	Allen Key 	1
H.	Cam Screw 	4
I.	Cam Lock 	4

\*Screw Driver and Hammer Not Provided

# MODEL : NEWTON (NIGHT STAND)

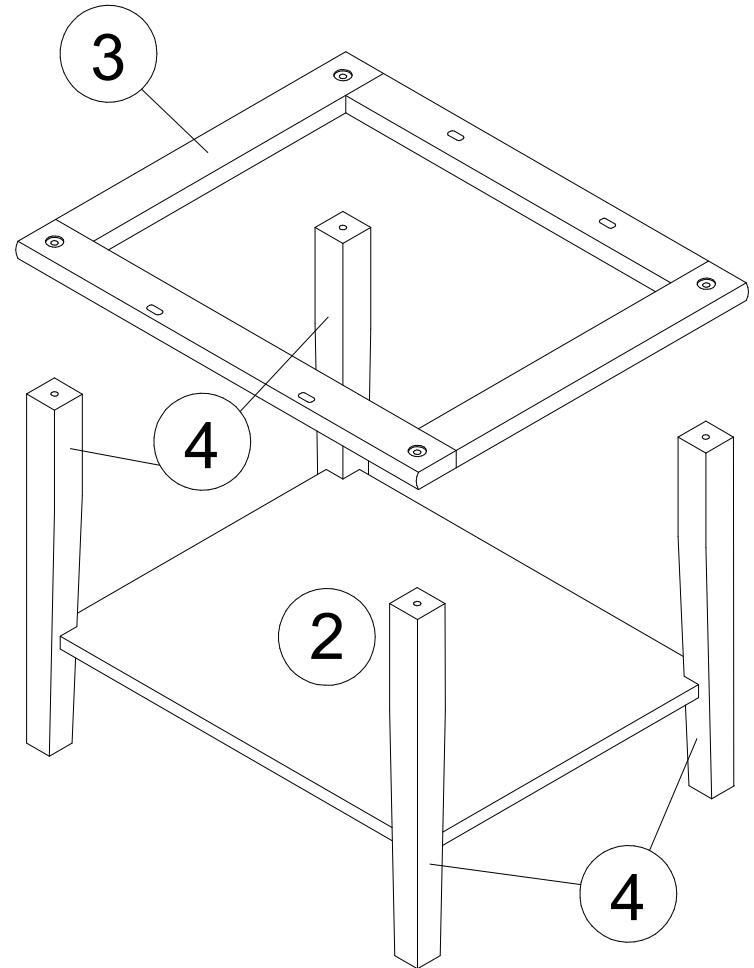
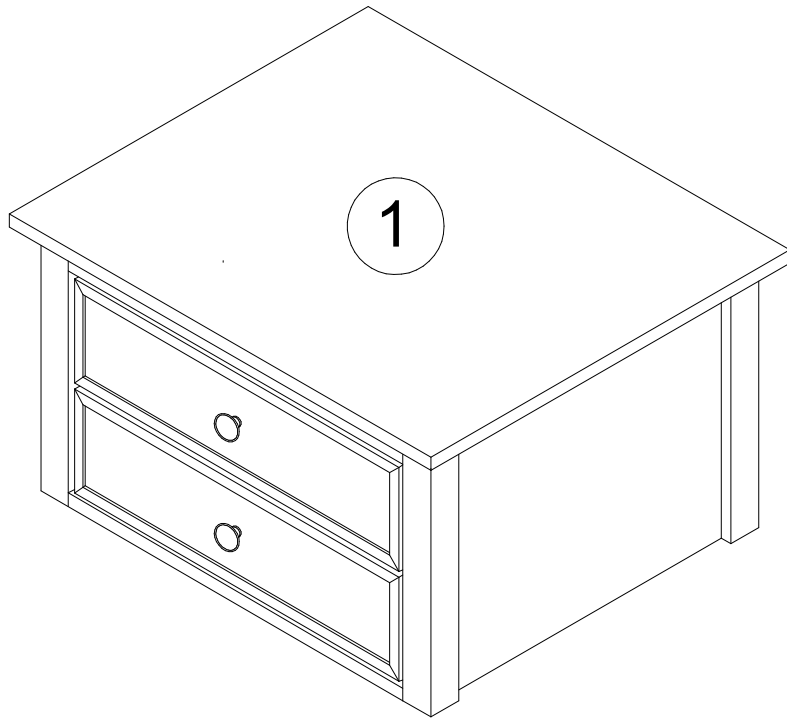

# ASSEMBLY INSTRUCTION

## MODEL : NEWTON (NIGHT STAND)

### STEP 1.

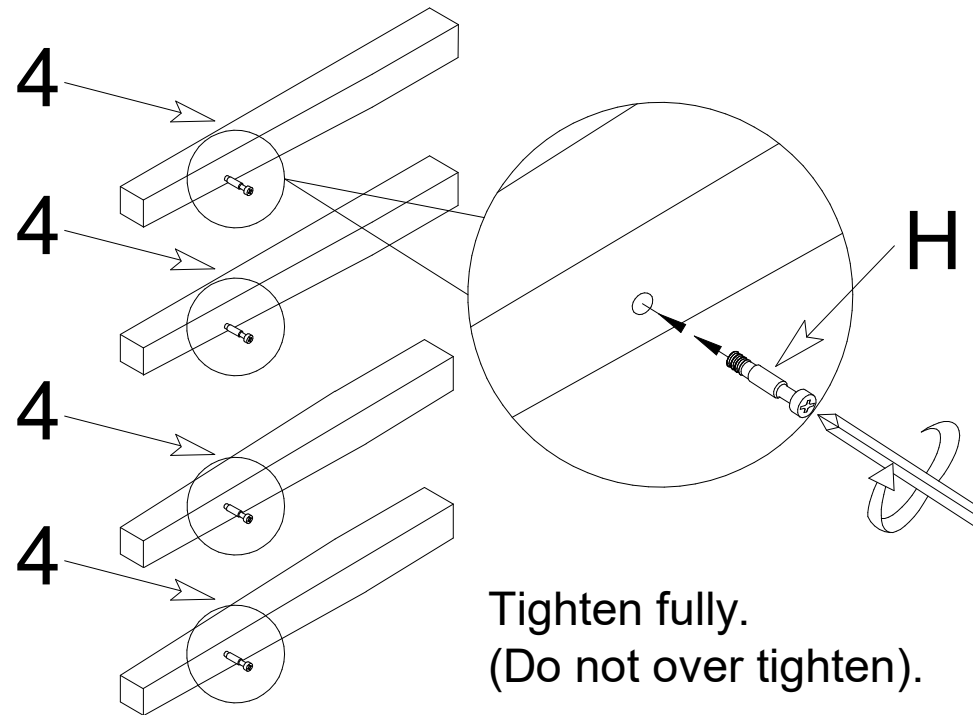

Tighten fully.  
(Do not over tighten).

### STEP 2.

Proper orientation  
of Cam Lock (I).  
1/2 turn to fully  
lock.

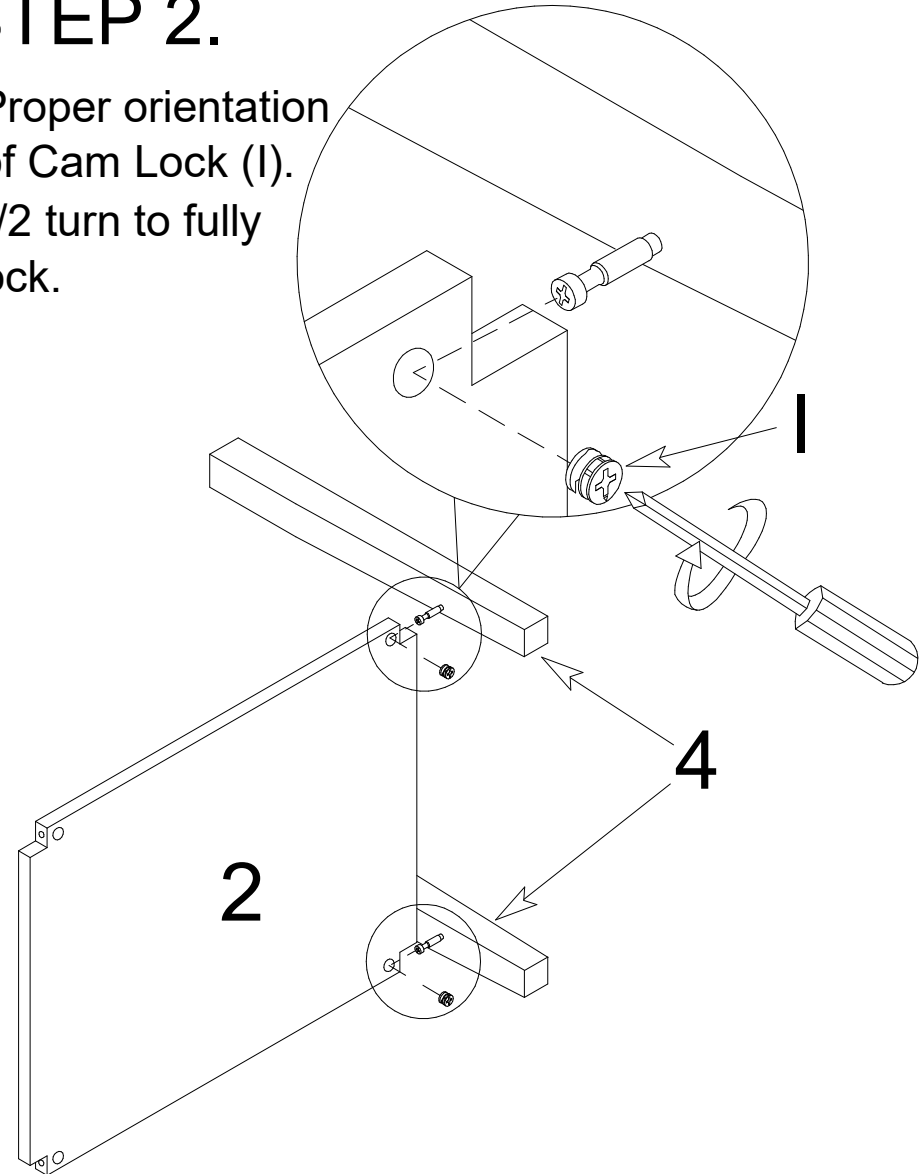

# ASSEMBLY INSTRUCTION

## MODEL : NEWTON (NIGHT STAND)

### STEP 3.

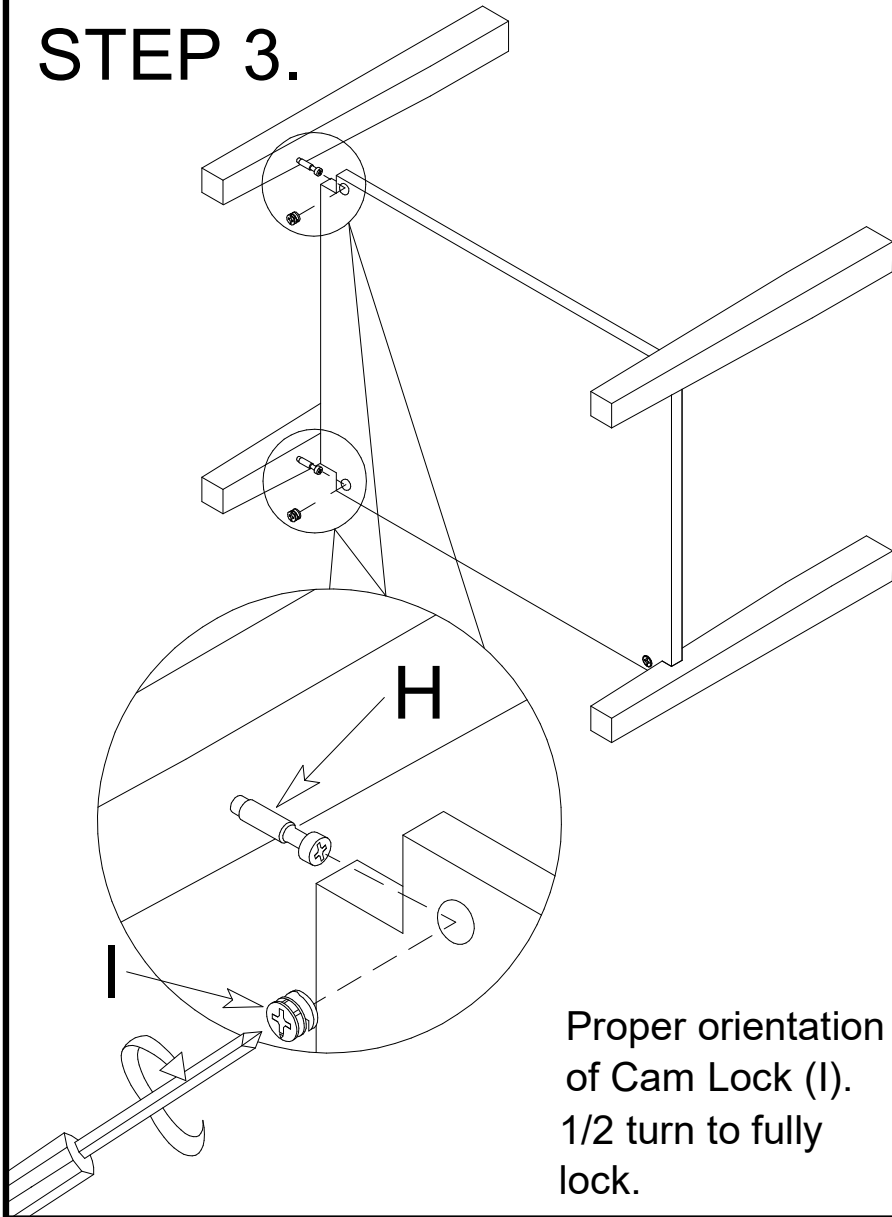

### STEP 4.

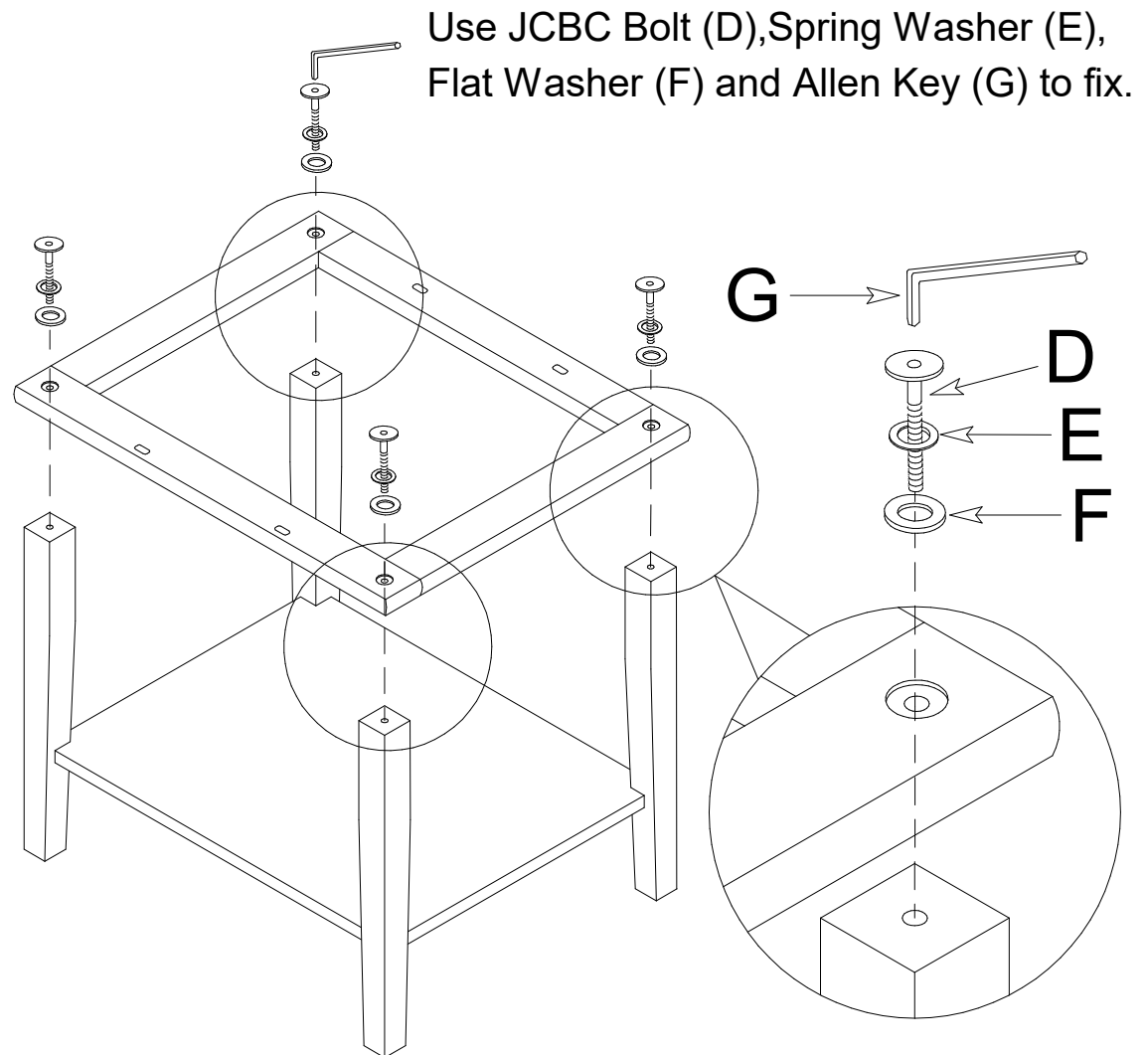

# ASSEMBLY INSTRUCTION

## MODEL : NEWTON (NIGHT STAND)

### STEP 5.

Use JCBC Bolt (C), Spring Washer (E), Flat Washer (F) and Allen Key (G) to fix.

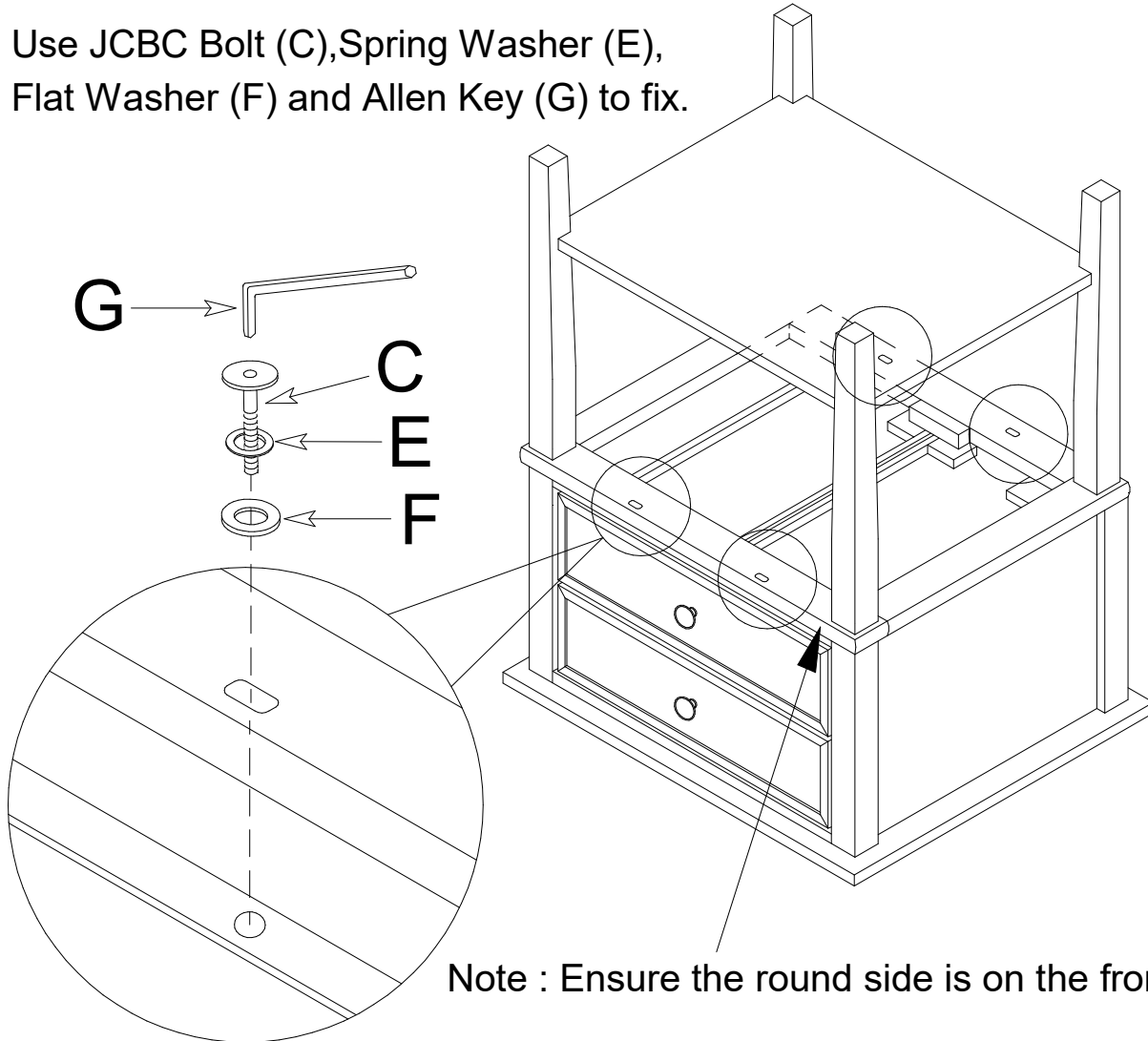

### STEP 6.

Attach handle using handle screw (B).

