

# ASSEMBLY INSTRUCTIONS

## CABINET

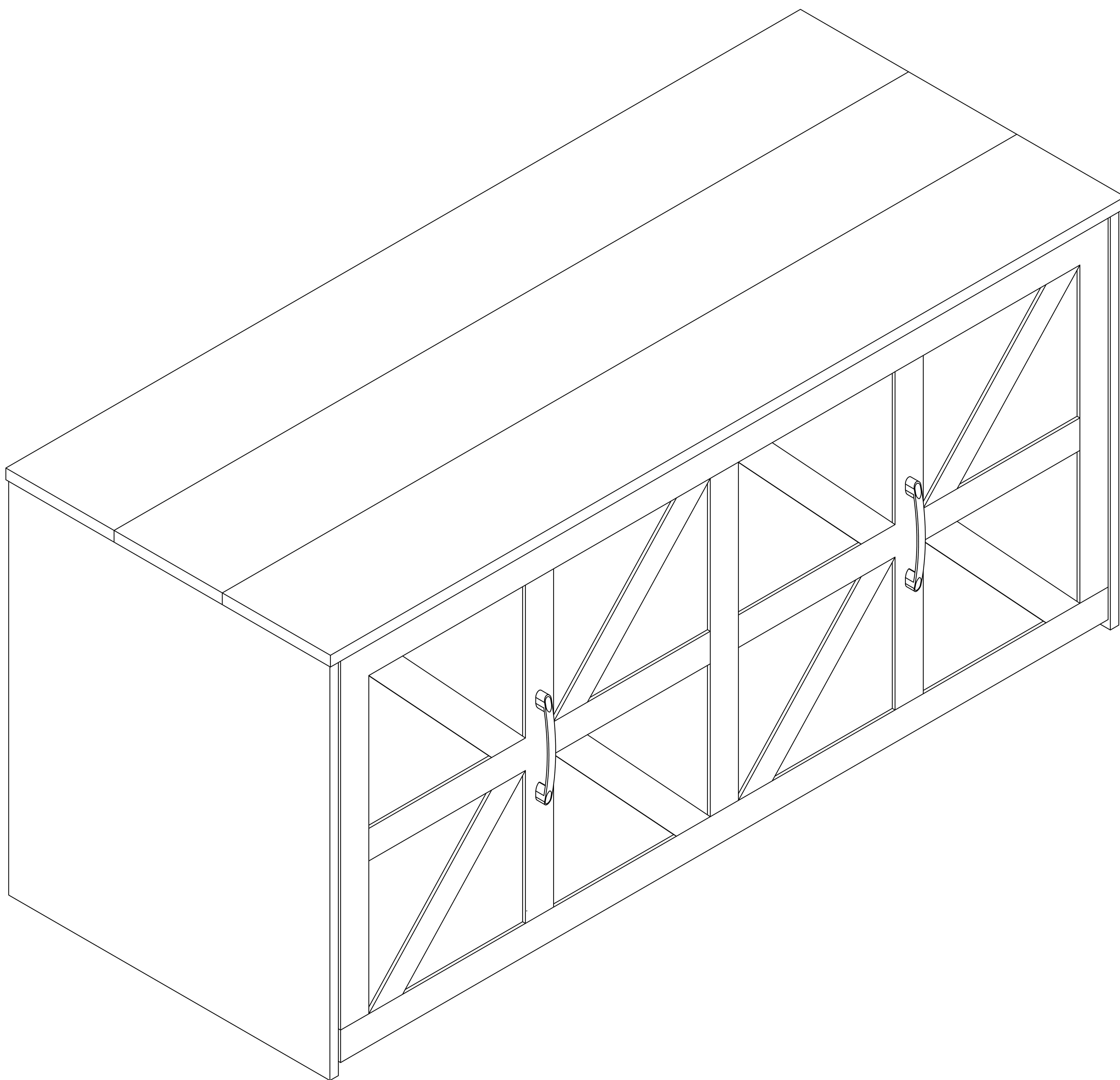

I1502510-F

# EXPLOSION FIGURE

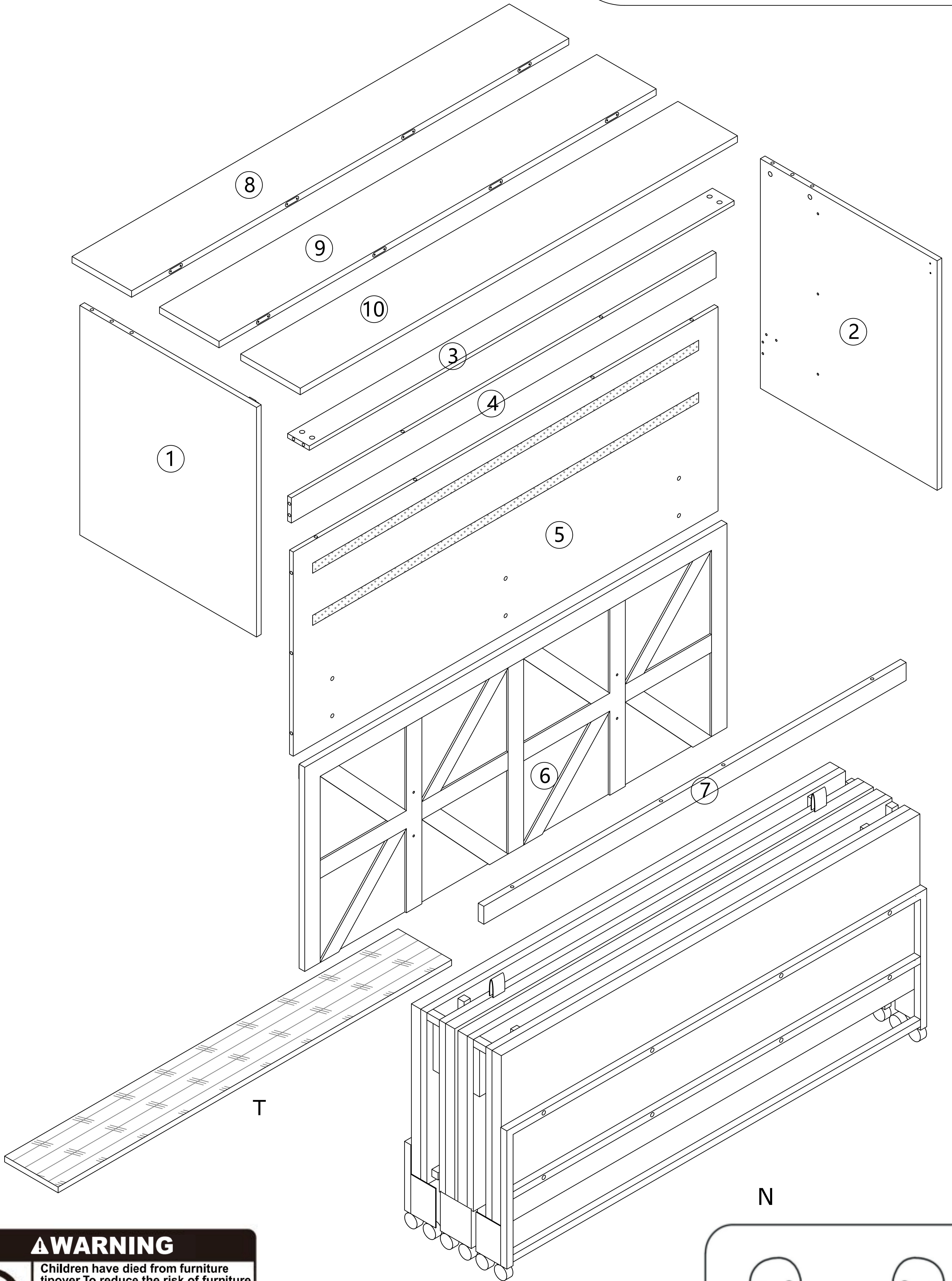

## ⚠ WARNING

Children have died from furniture tipover. To reduce the risk of furniture tipover:

- ALWAYS install Anti-tip device provided.
- NEVER put a TV on this product.
- NEVER allow children to stand, climb or hang on drawers, doors, or shelves.
- NEVER open more than one drawer at a time.
- Place heaviest items in the lowest drawers.

*This is a permanent label.  
Do not remove!*

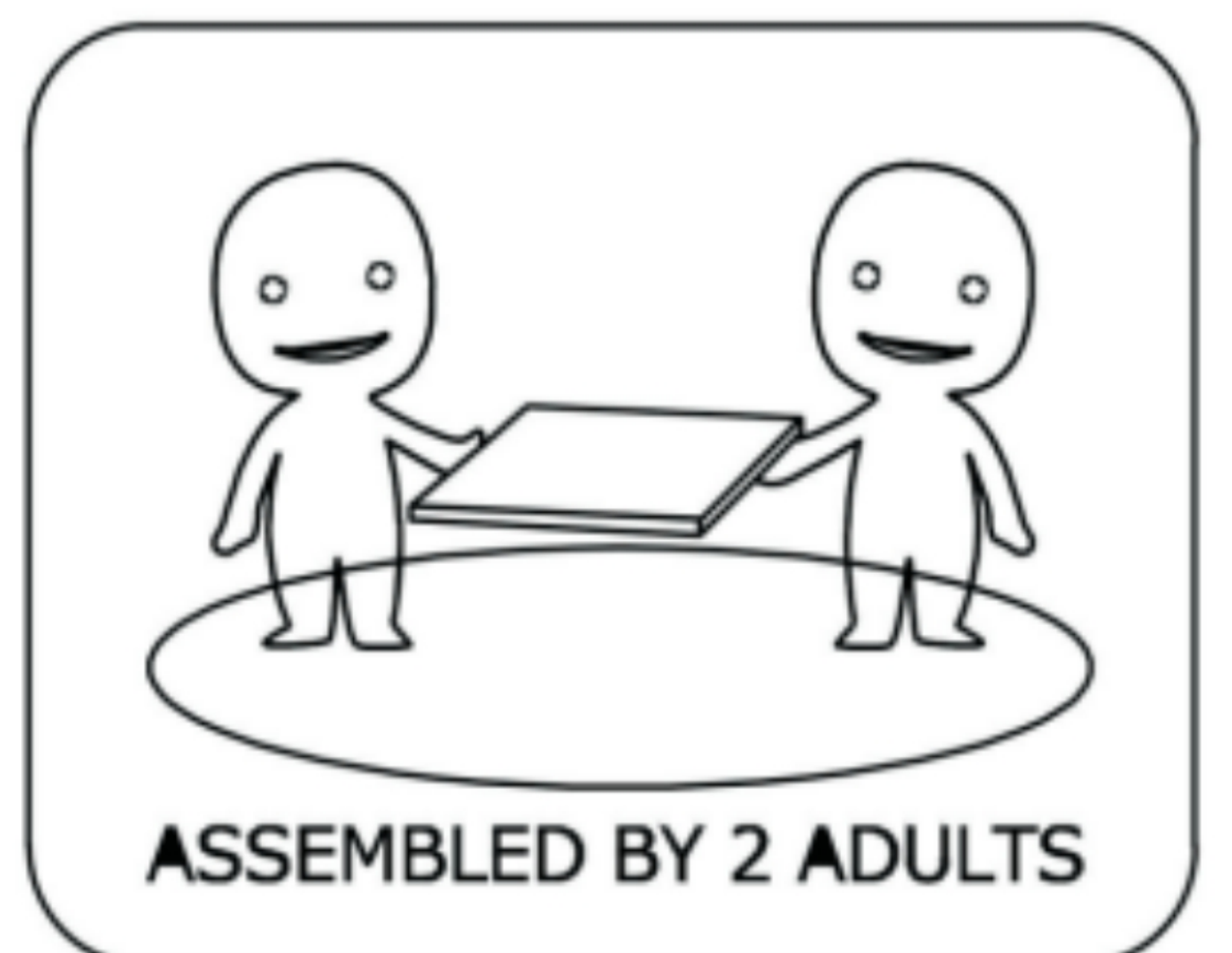

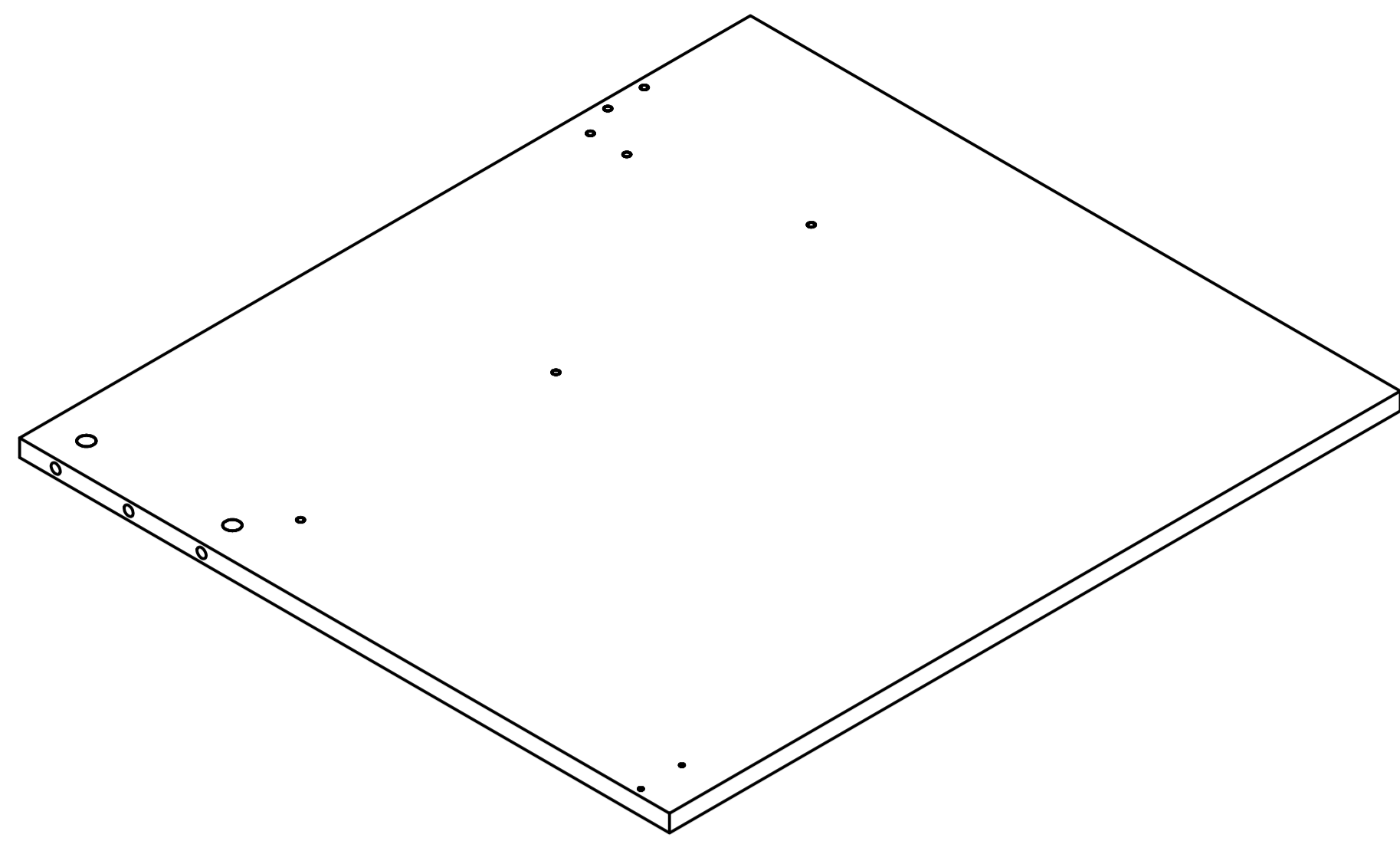

① x1

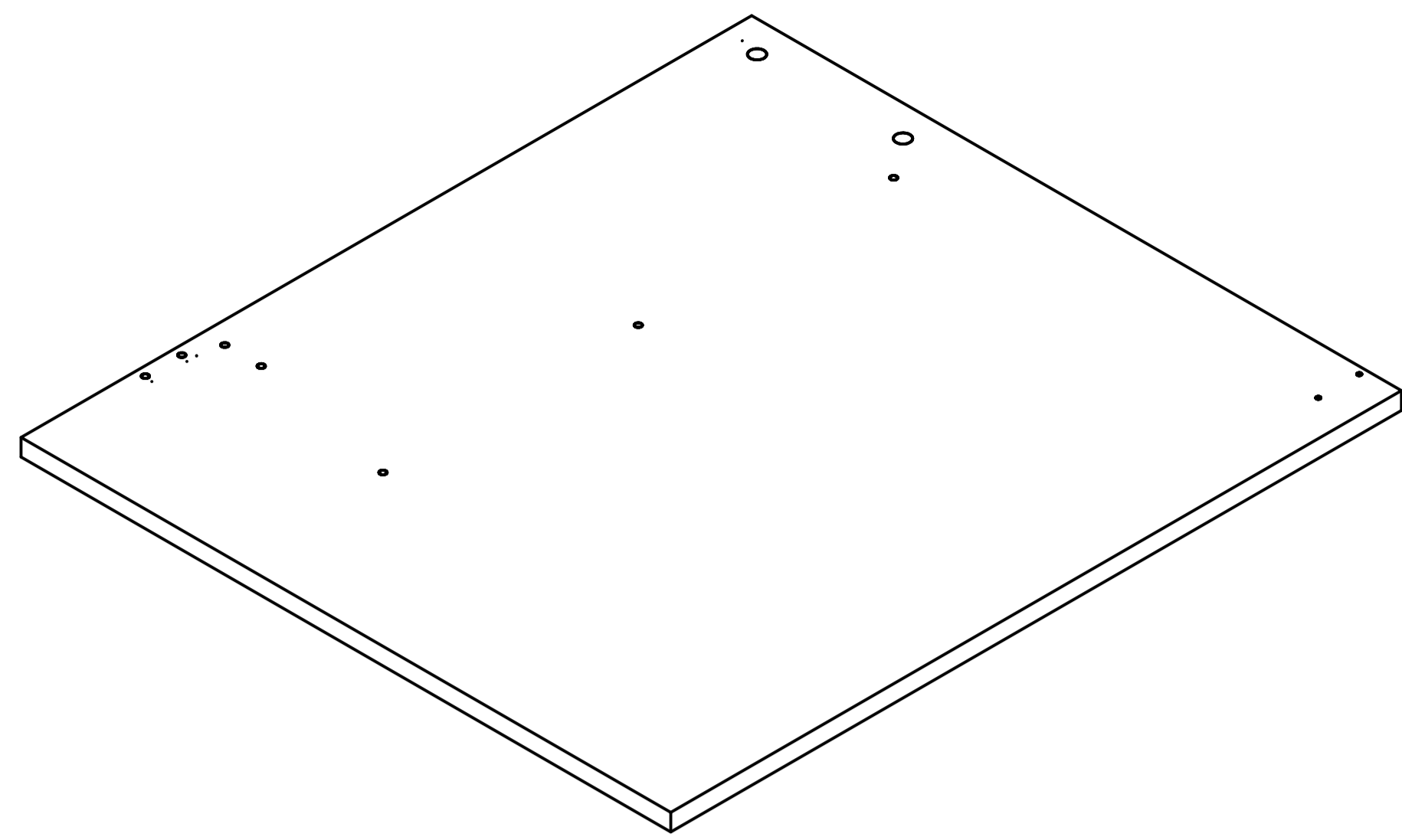

② x1

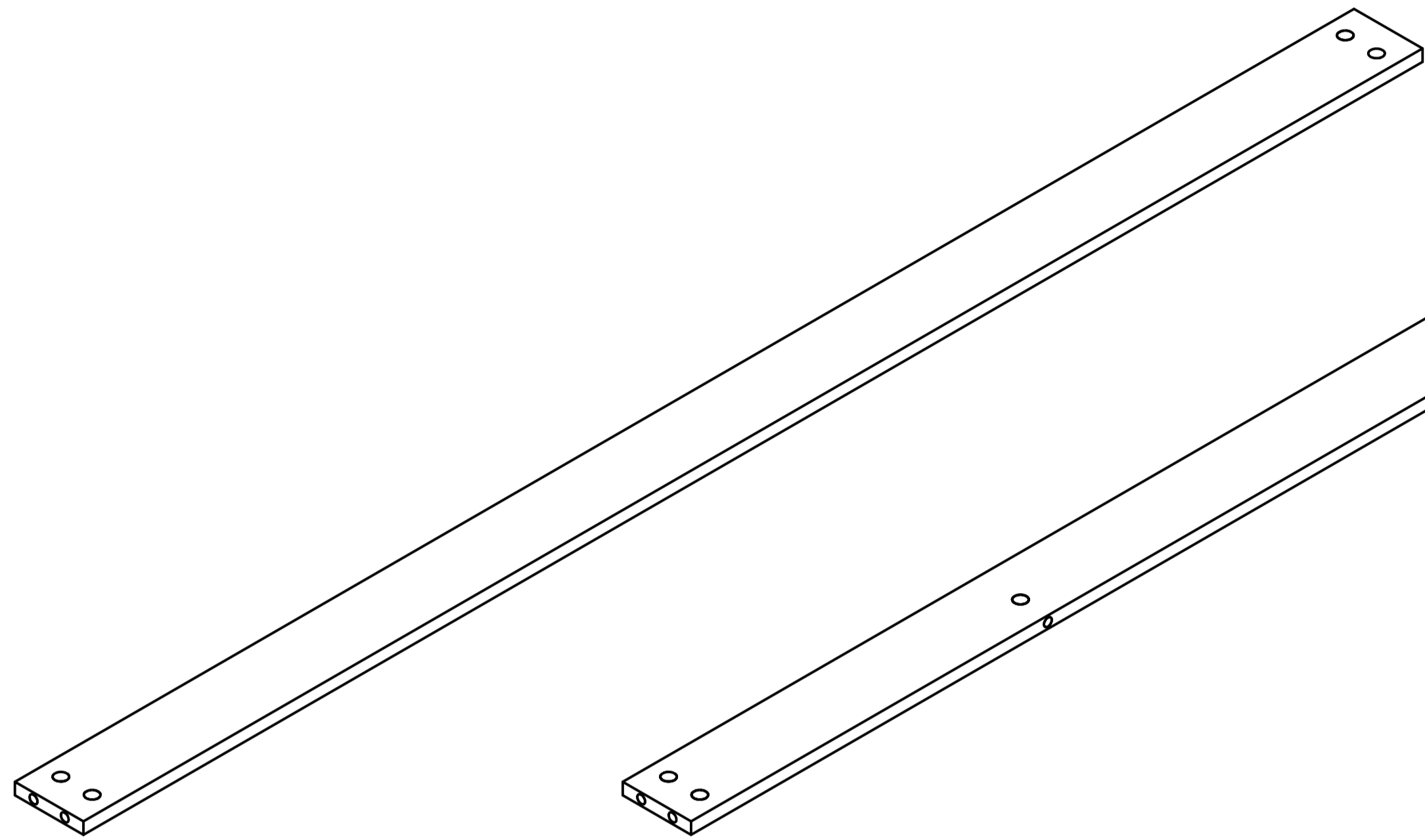

③ x1

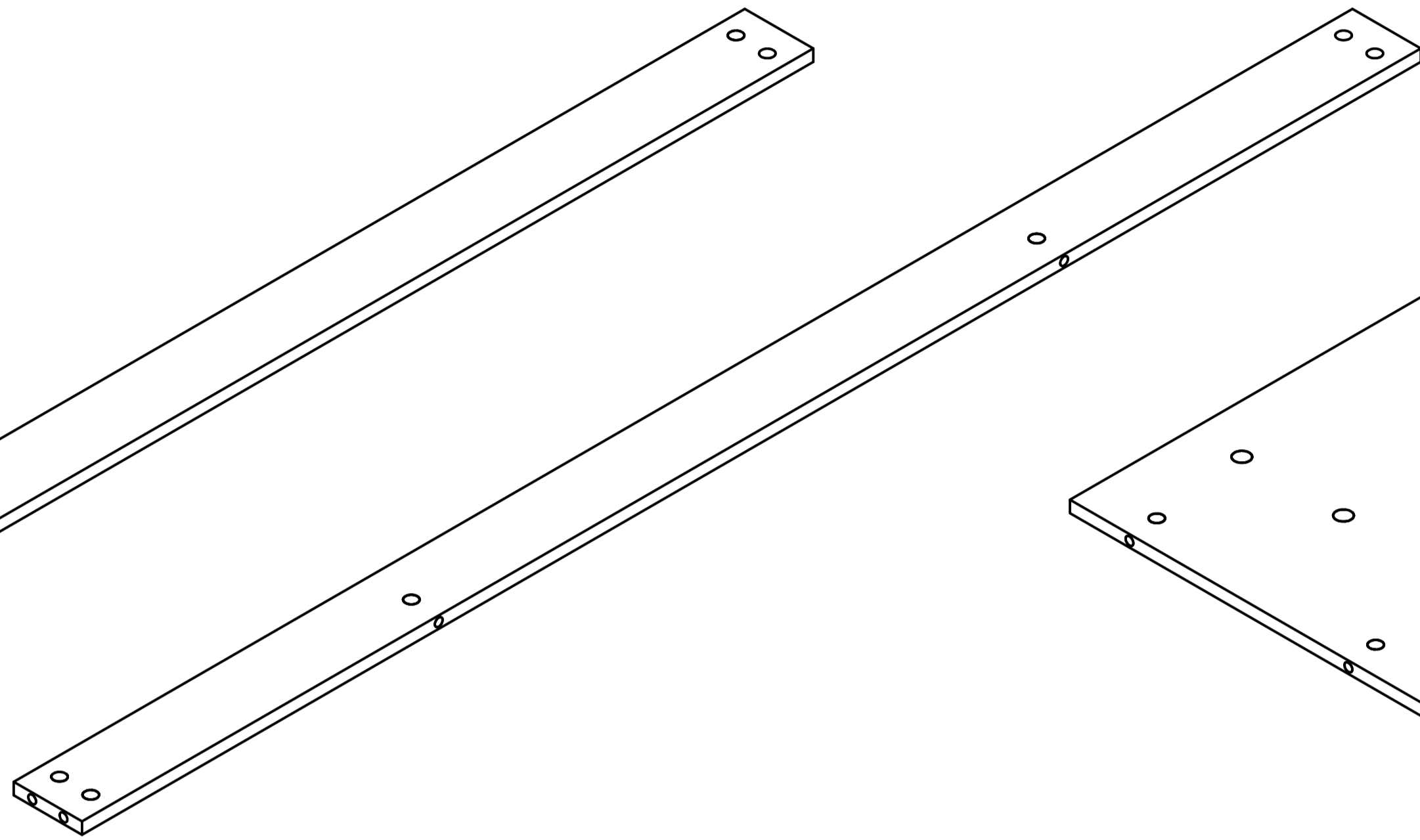

④ x1

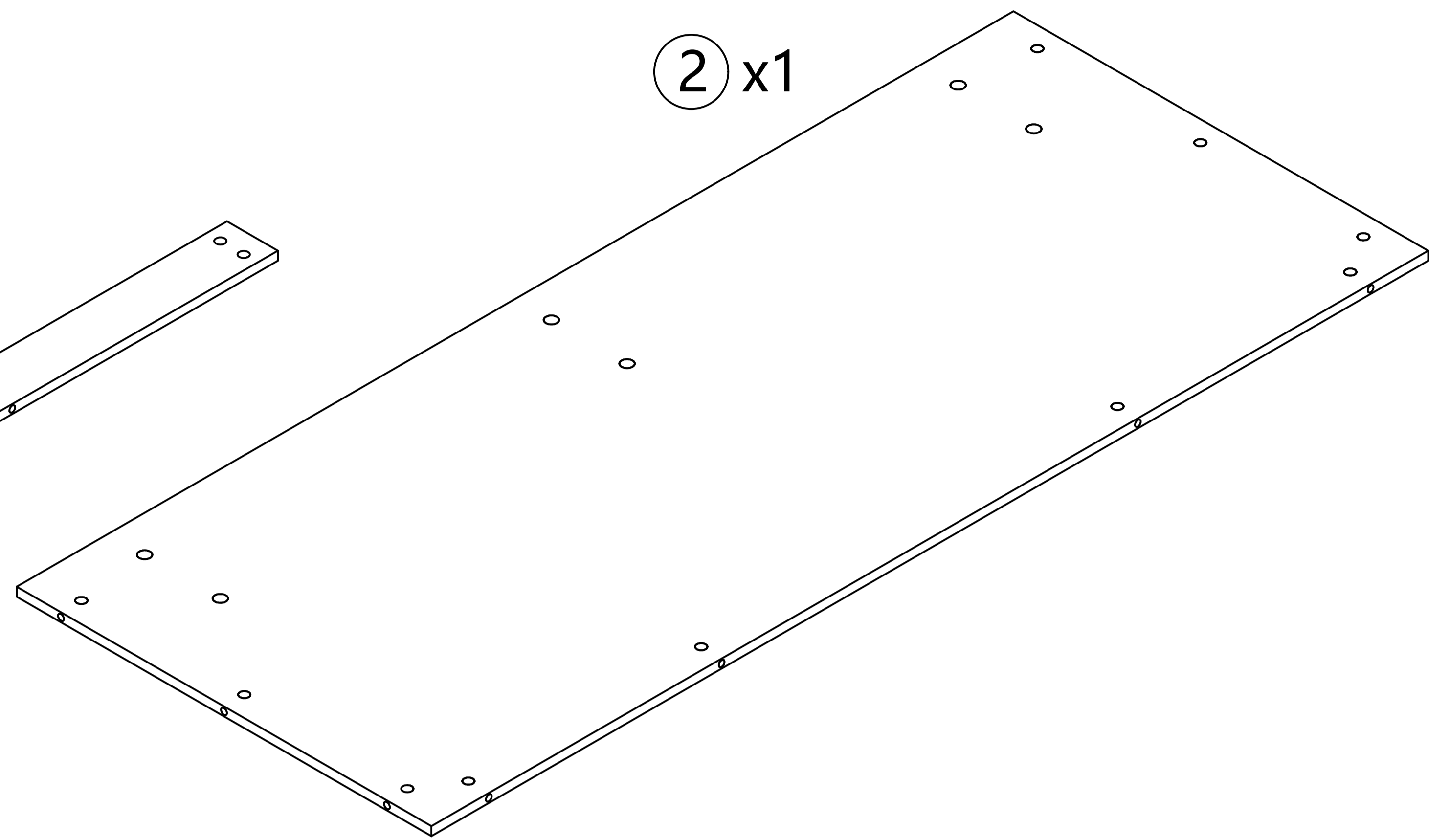

⑤ x1

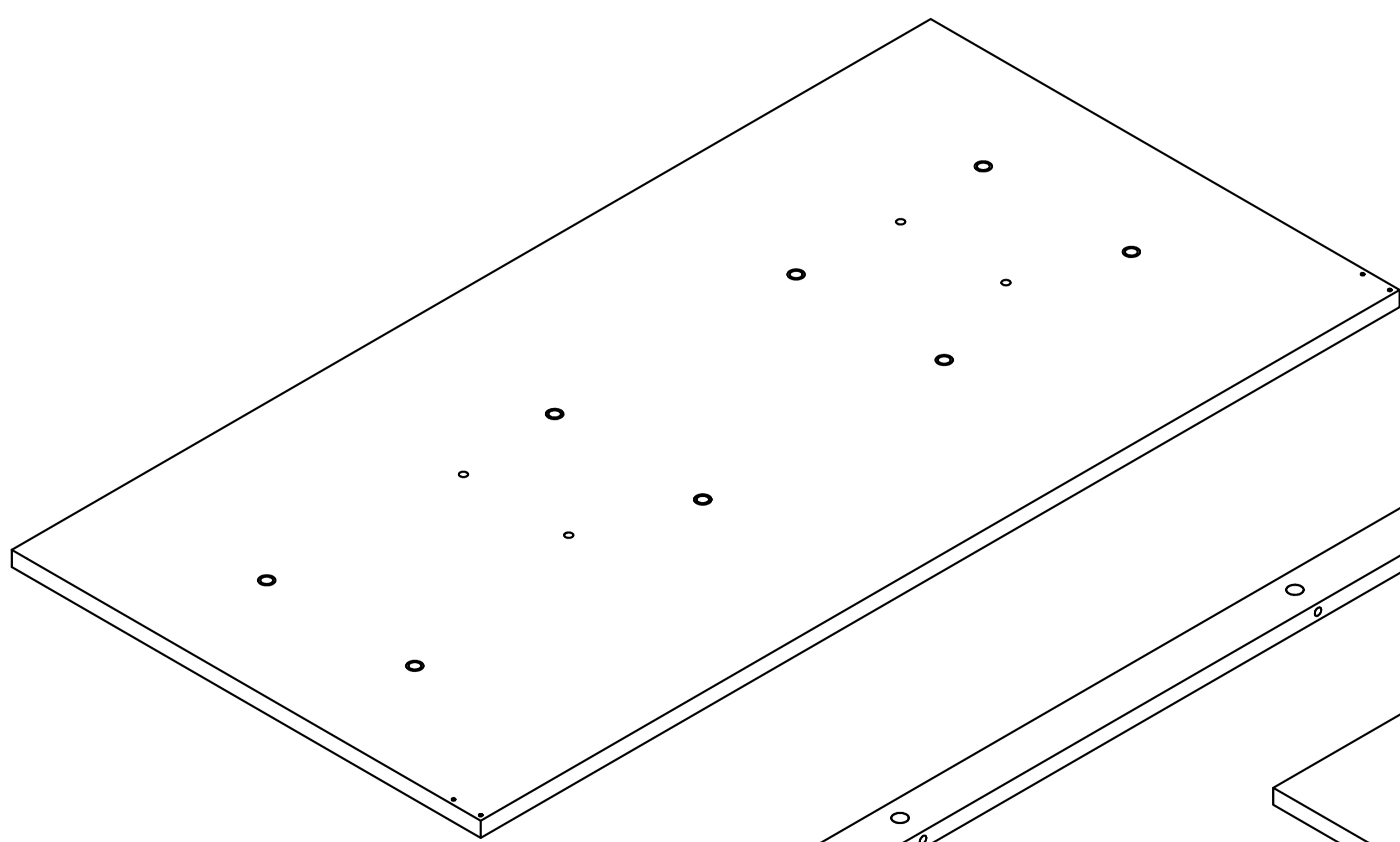

⑥ x1

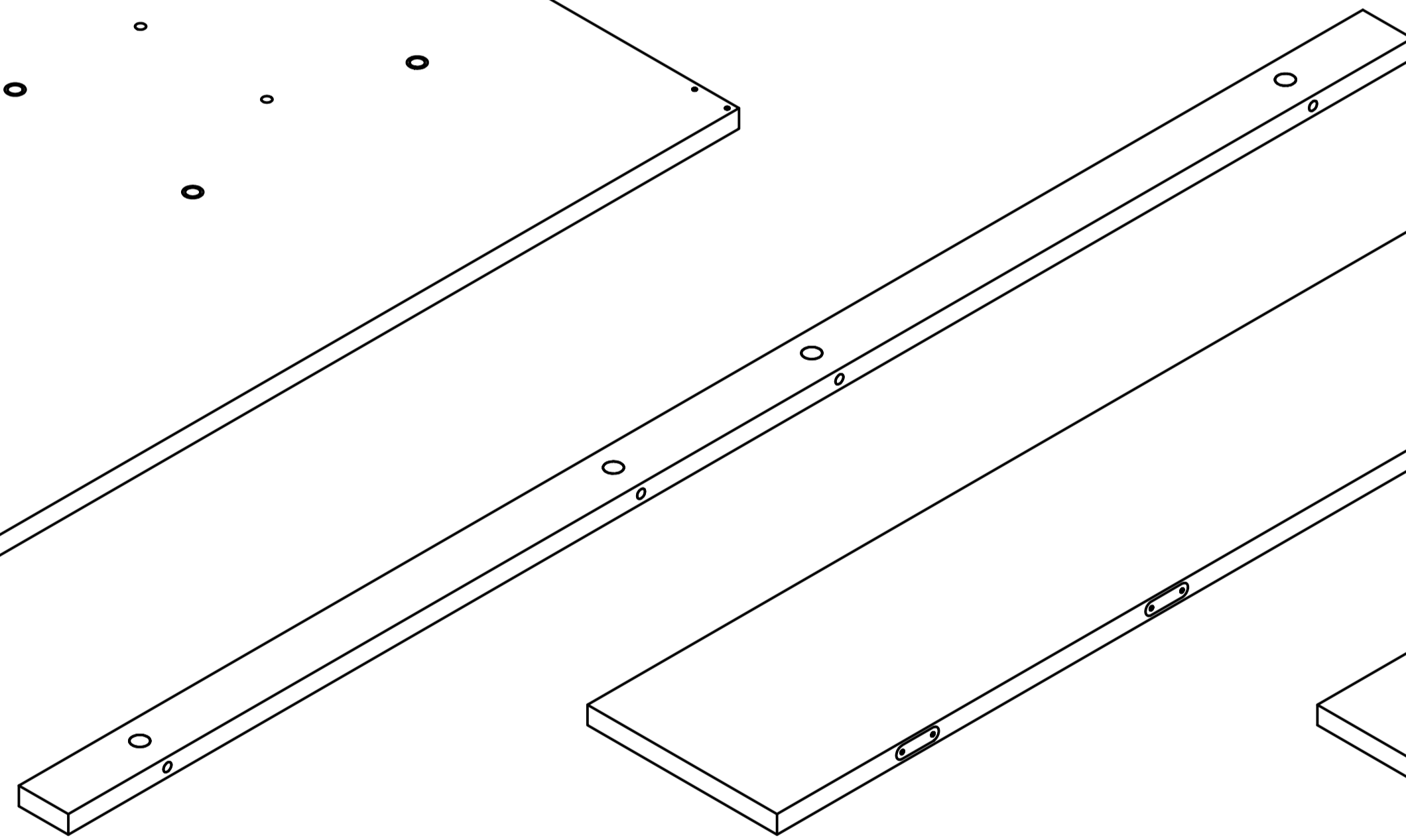

⑦ x1

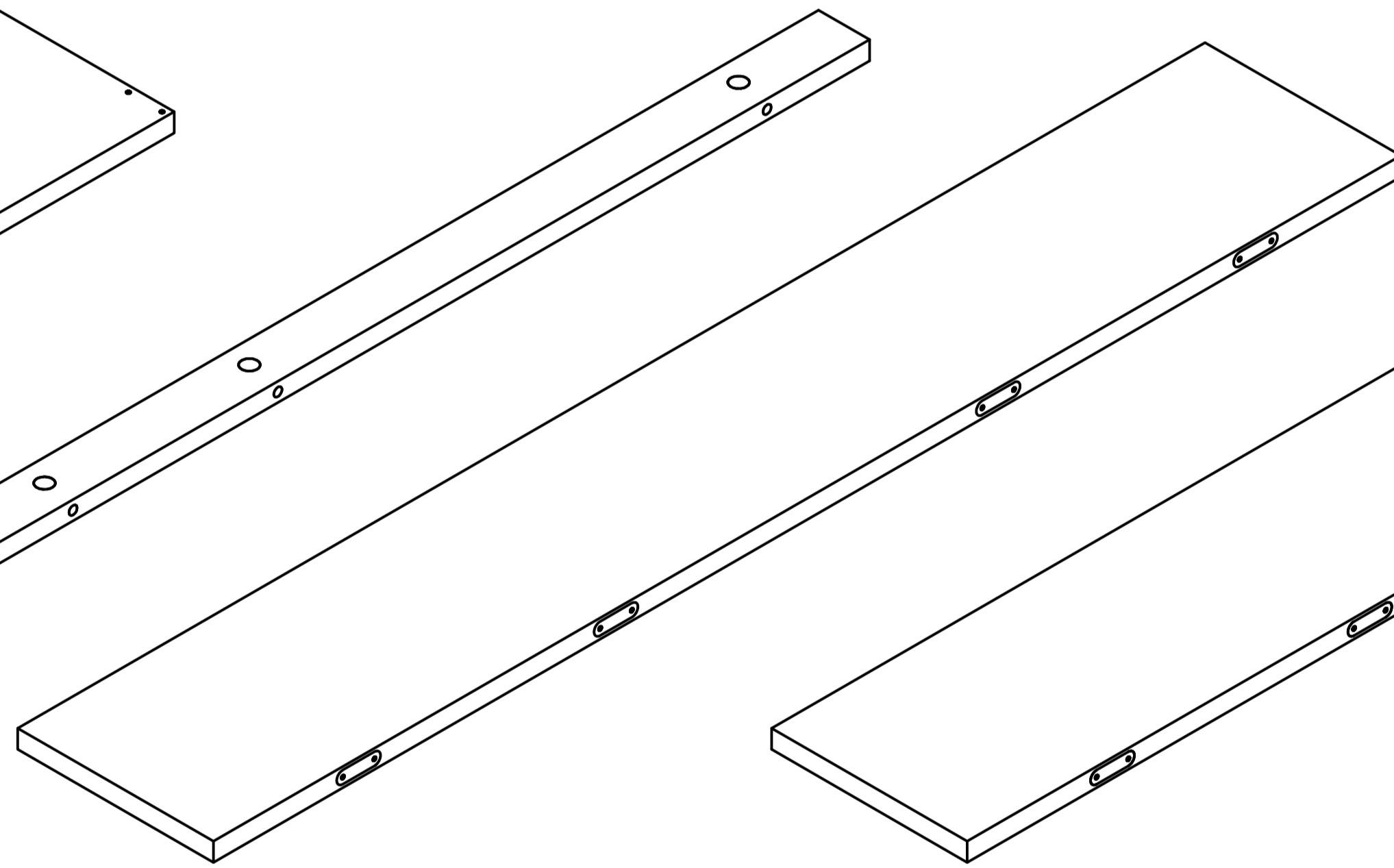

⑧ x1

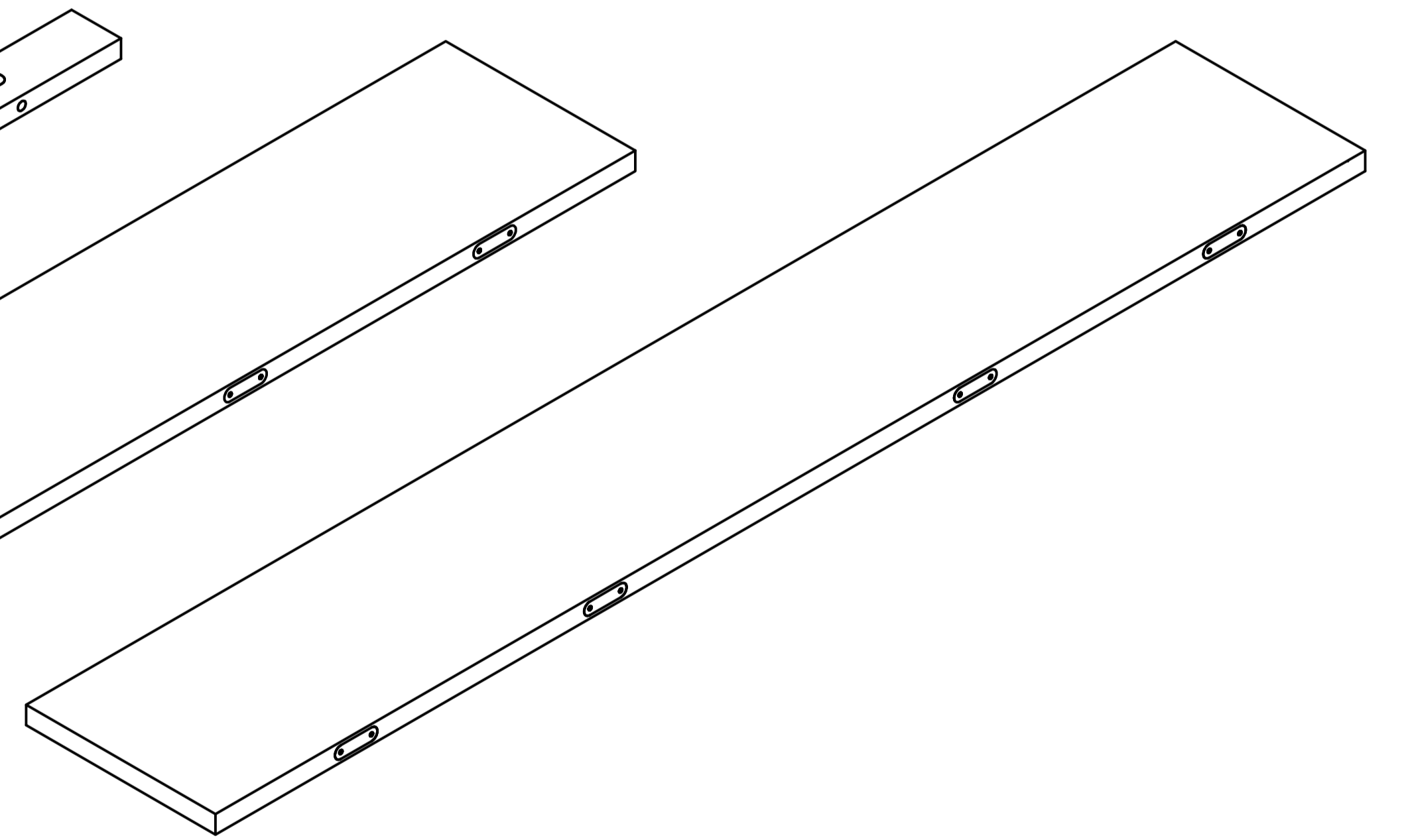

⑨ x1

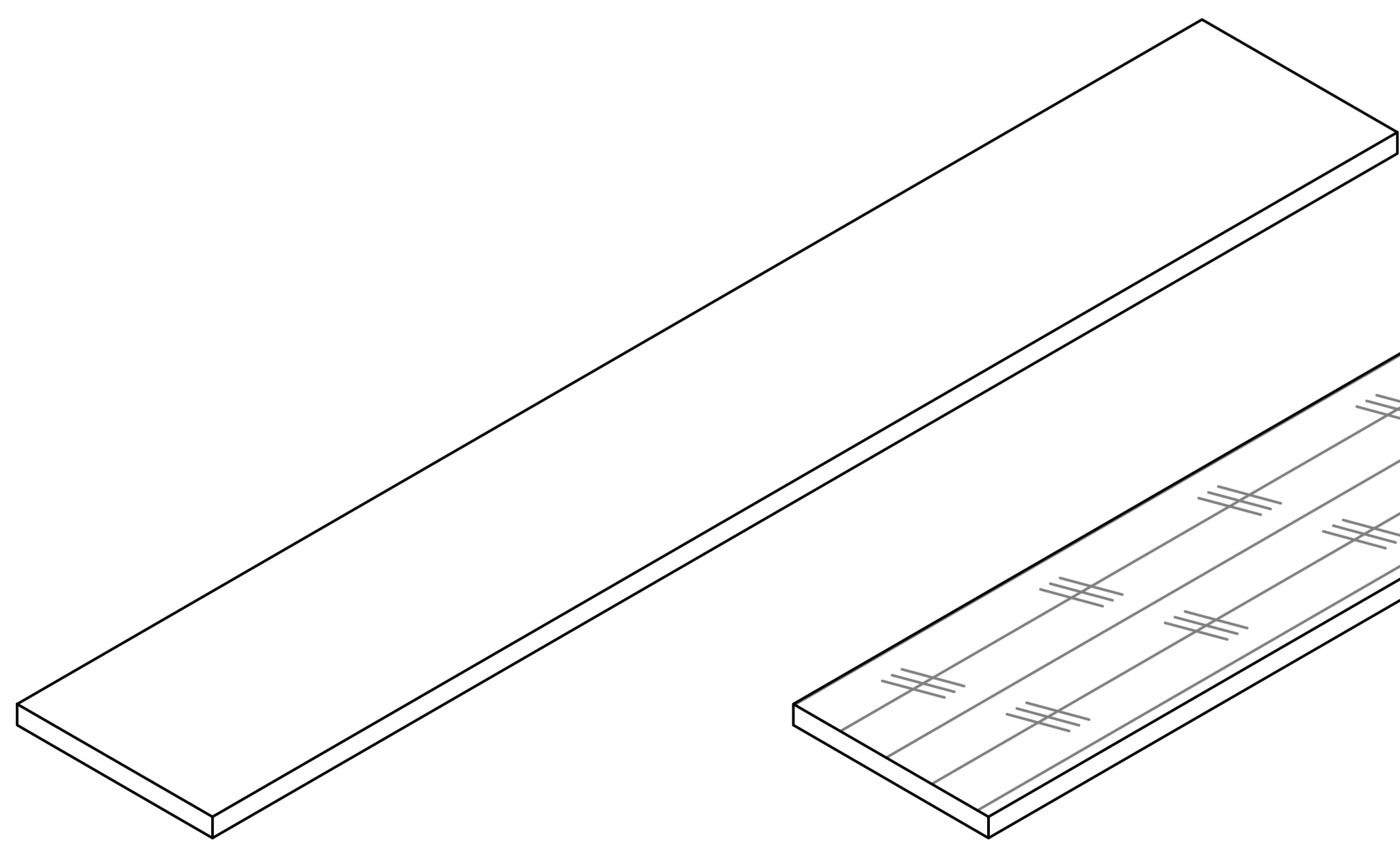

⑩ x1

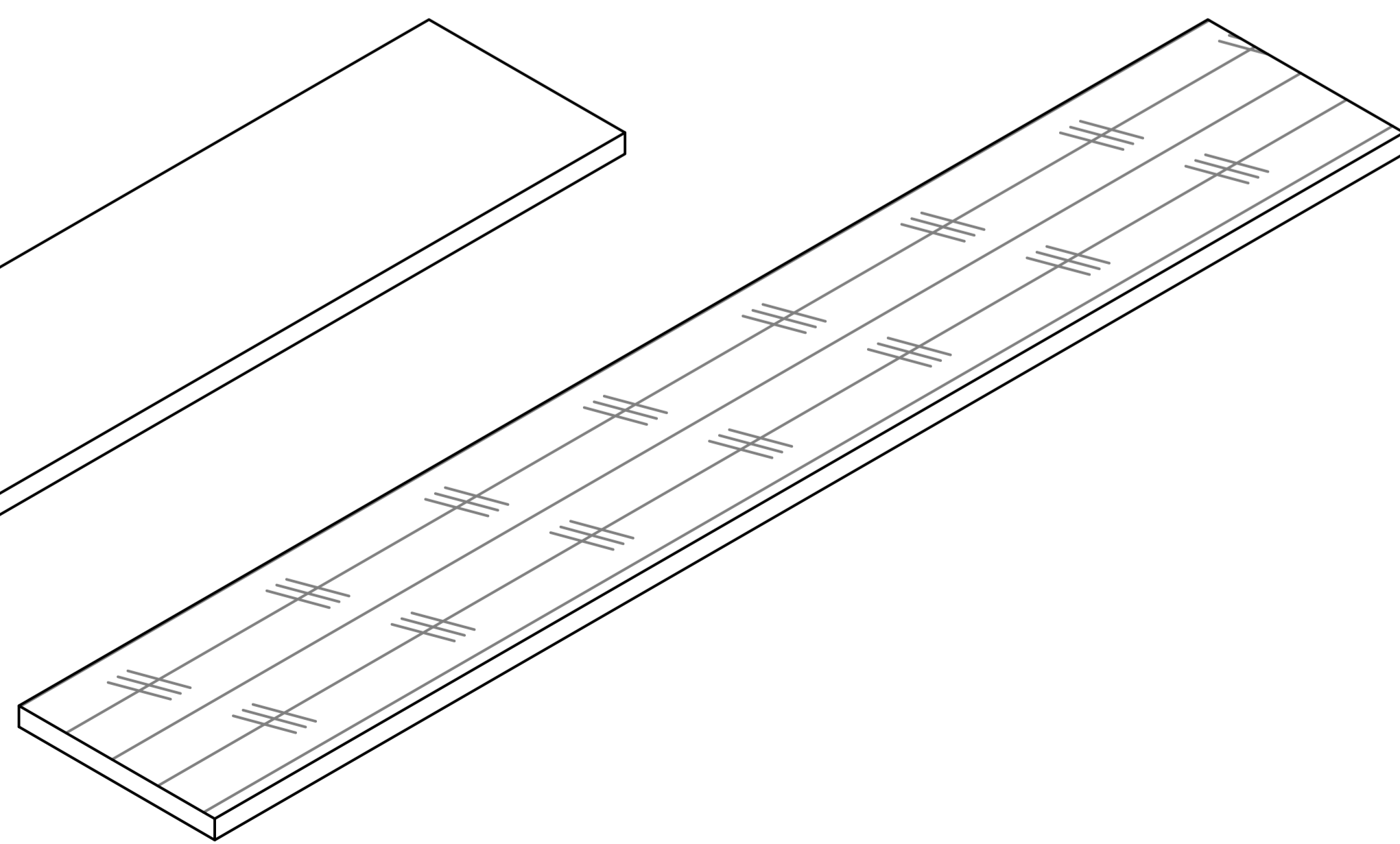

T x1

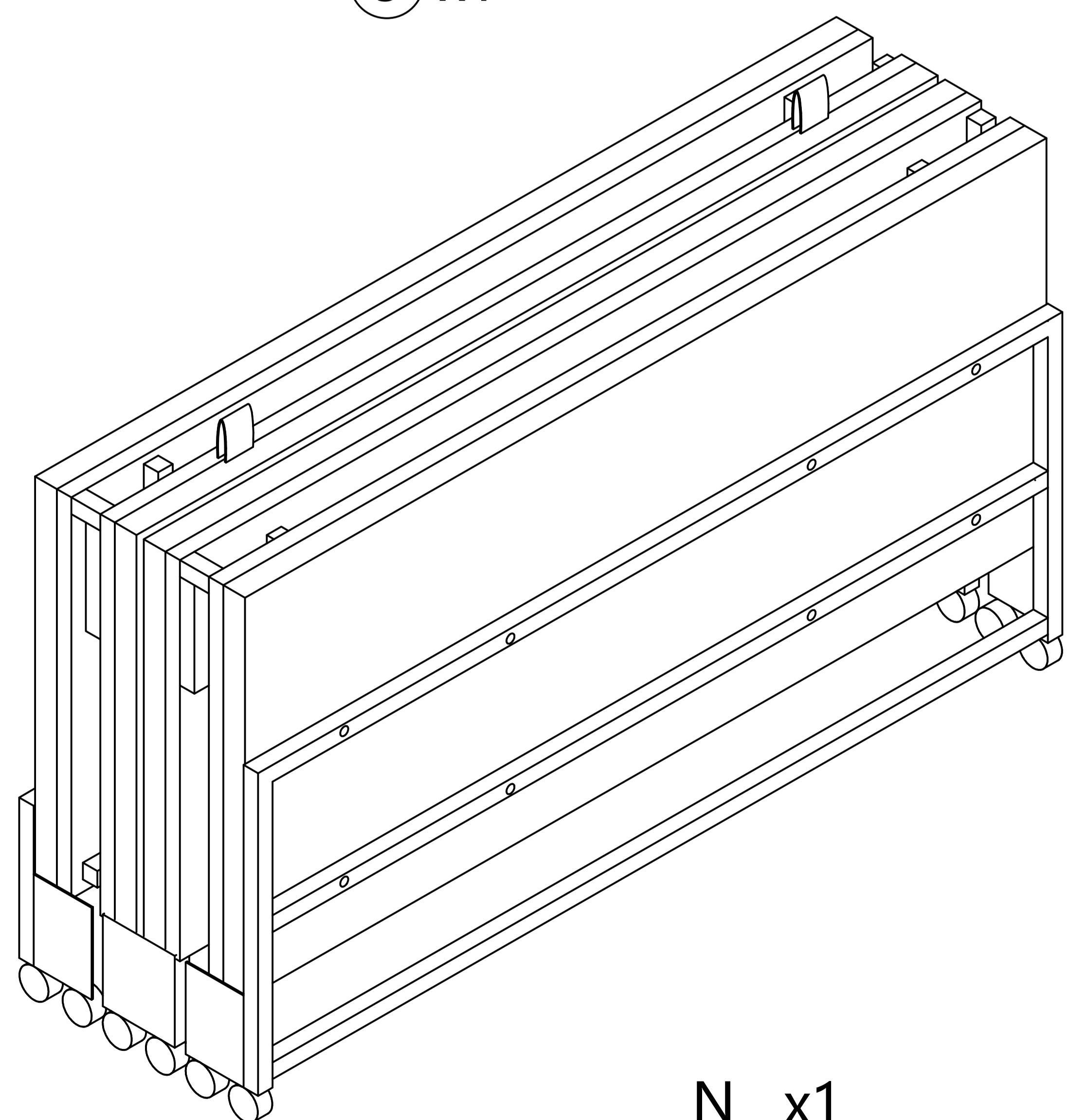

N x1

<p><b>A x 24</b></p>  <p>∅ 12 x 10 mm</p>	<p><b>B x 28</b></p>  <p>∅ 6 x 35 mm</p>	<p><b>C x 2</b></p>  <p>∅ 8 x 30 mm</p>	<p><b>D x 40</b></p>  <p>∅ 4 x 14 mm</p>
<p><b>E x 2</b></p> 	<p><b>F x 4</b></p>  <p>∅ 15 x 12 mm</p>	<p><b>G x 2</b></p> 	<p><b>H x 14</b></p> 
<p><b>J x 2</b></p> 	<p><b>K x 4</b></p>  <p>∅ 4 x 19 mm</p>	<p><b>M x 8</b></p> 	<p><b>N x 1</b></p> 
<p><b>O x 6</b></p>  <p>∅ 6 x 50 mm</p>	<p><b>P x 8</b></p>  <p>∅ 6 x 25 mm</p>	<p><b>Q x 4</b></p>  <p>Plastic gasket</p>	<p><b>R x 8</b></p>  <p>Iron gasket</p>
<p><b>S x 6</b></p> 	<p><b>T x 1</b></p> 	<p><b>U</b></p> 	<p><b>W</b></p> 

## Cam Lock Fastening System

This Cam Lock Fastening System will be used throughout the assembly process

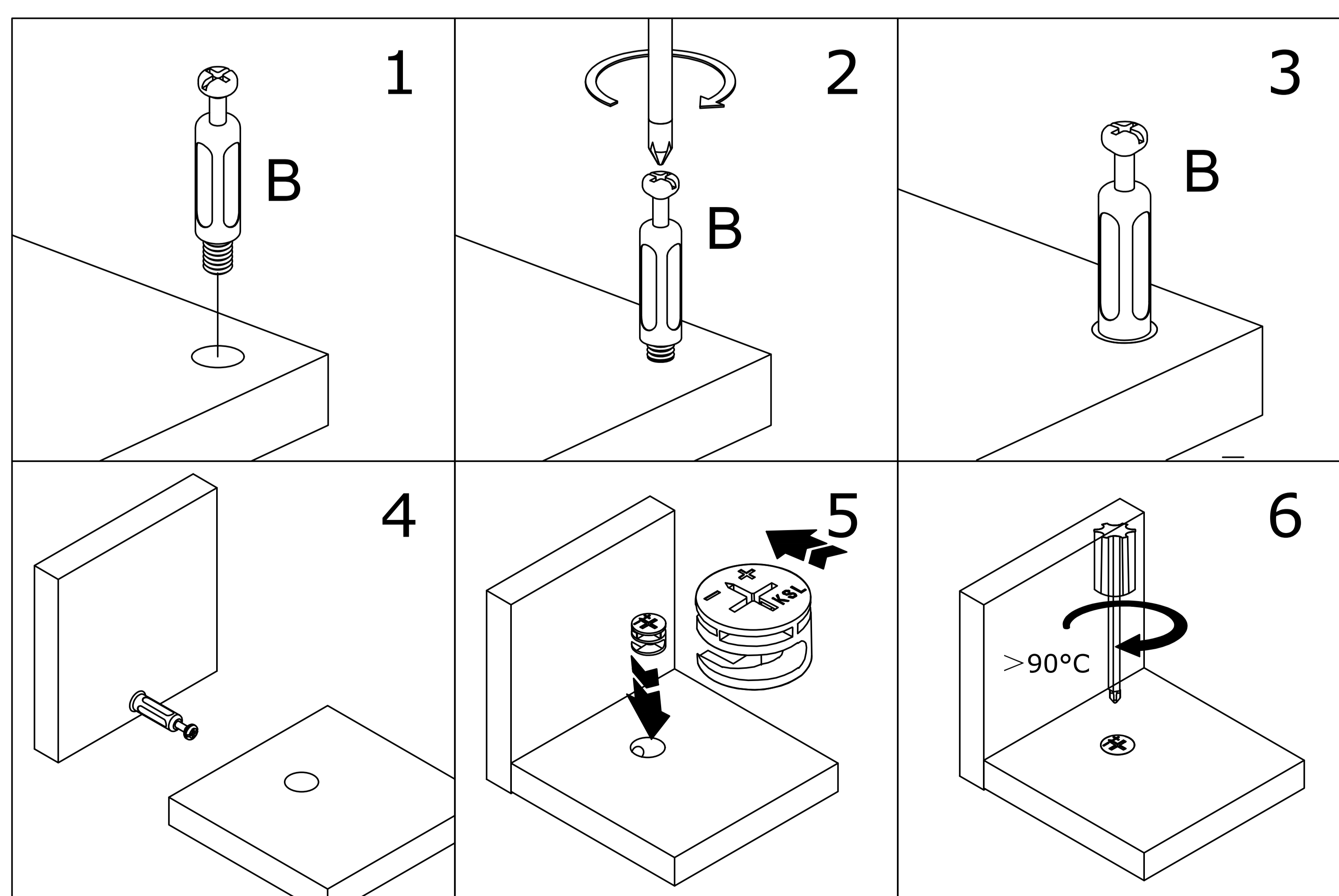
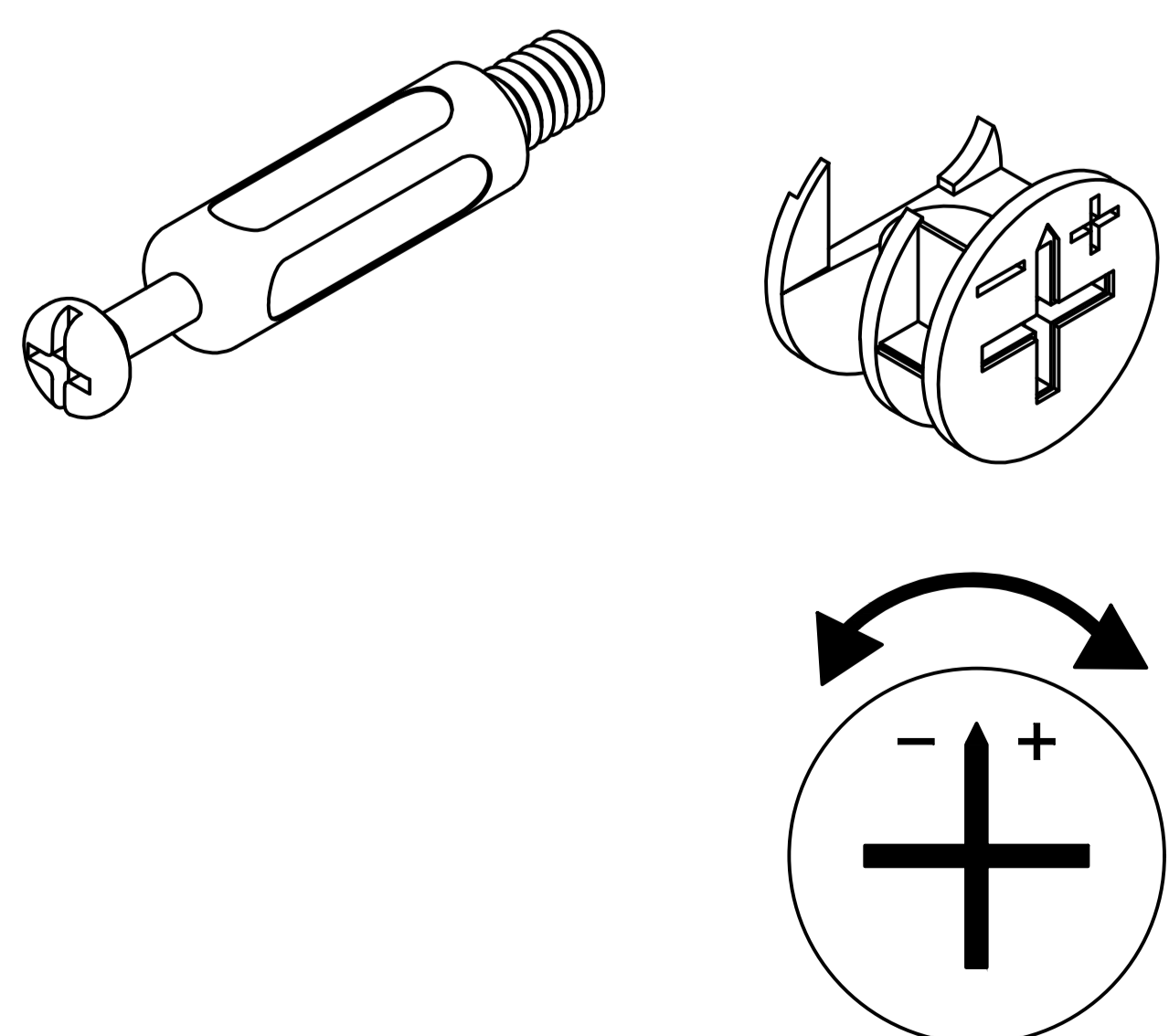

Point the opening towards the edge of the board.

1

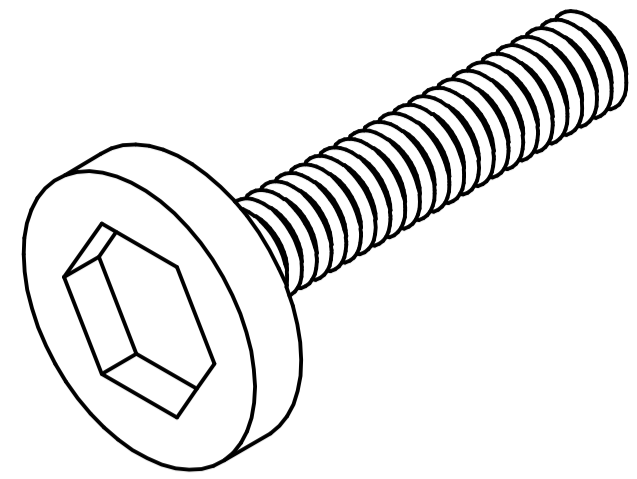
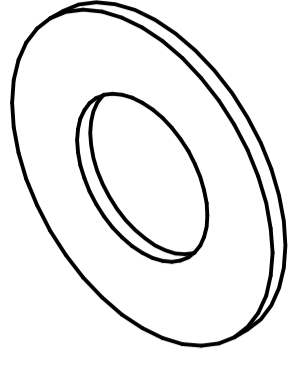
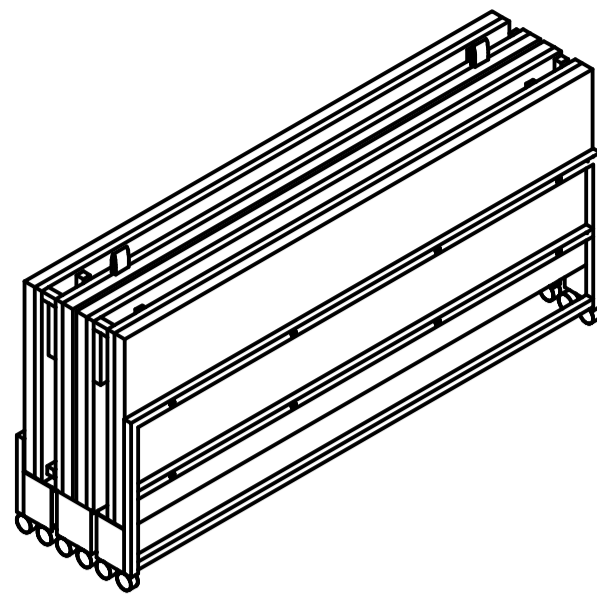
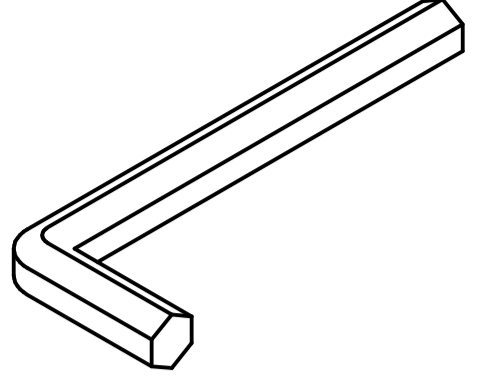
<p>P x 8</p>  <p>Ø 6 x 25 mm</p>	<p>R x 8</p>  <p>Iron gasket</p>	<p>N x 1</p> 		<p>U</p> 
---	---	--	--	--

- Refer to the illustration.  
Screw (P) passes through (R) and is connected and fixed to (N).

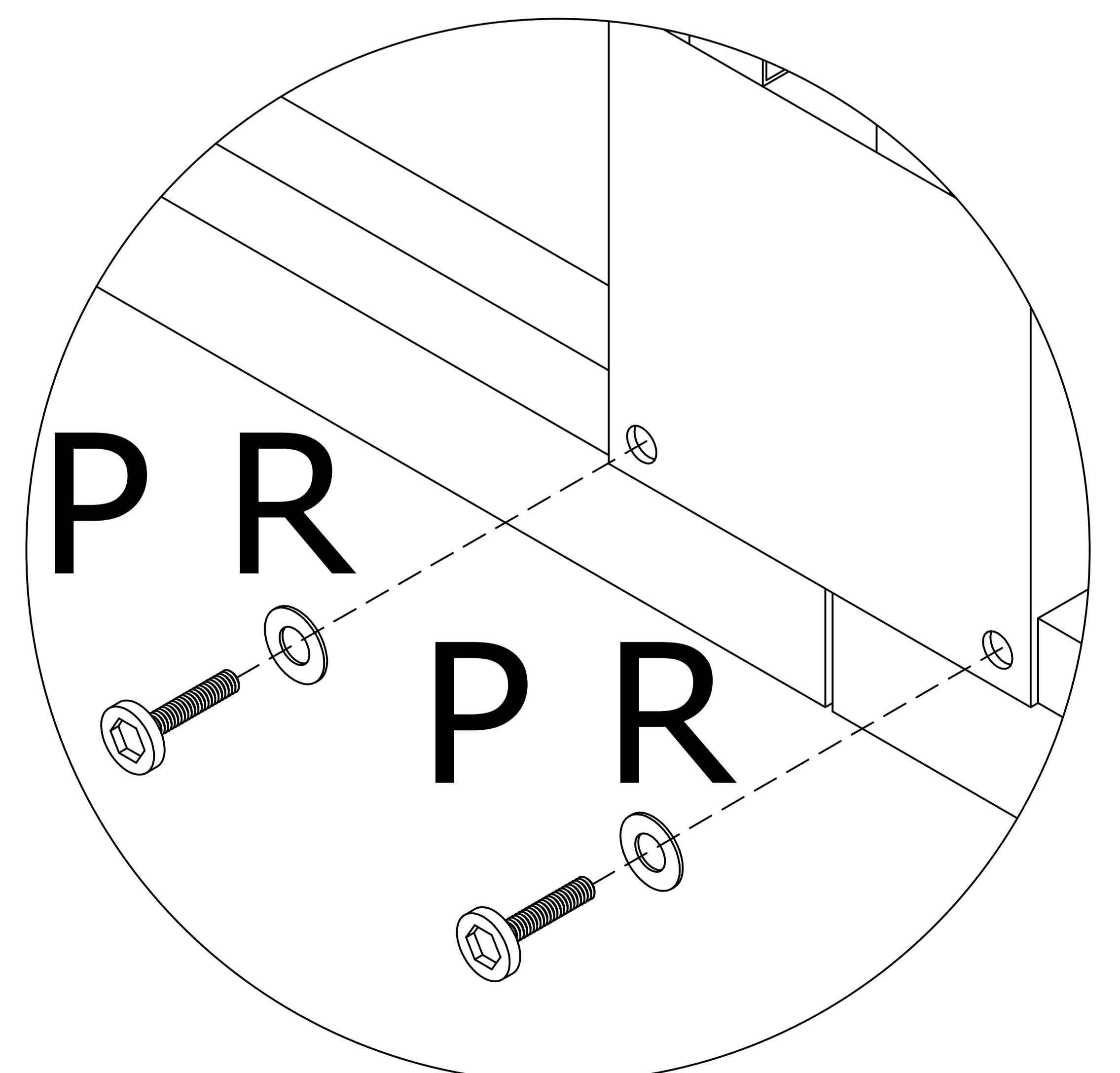
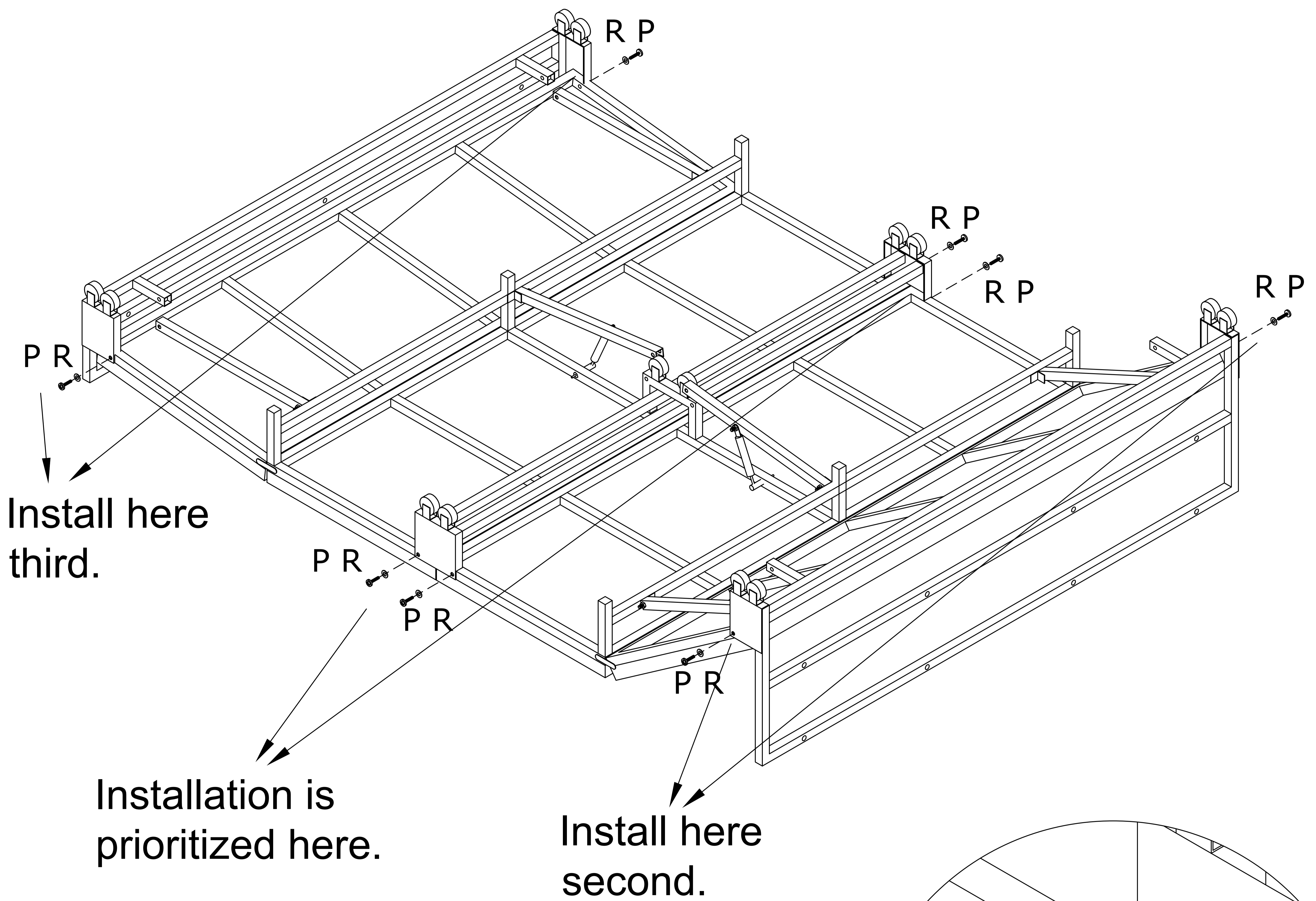

2

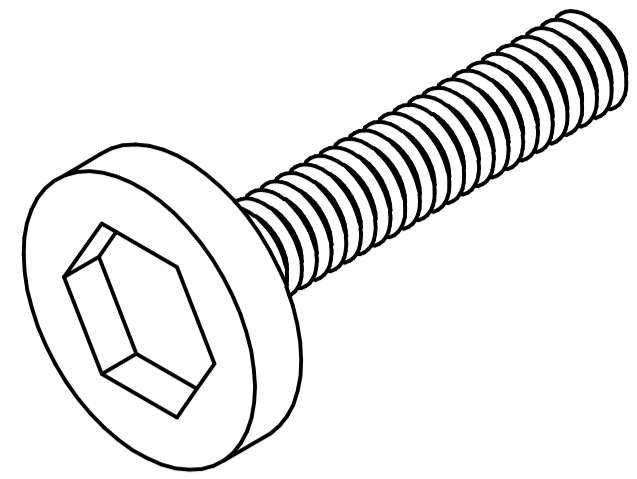
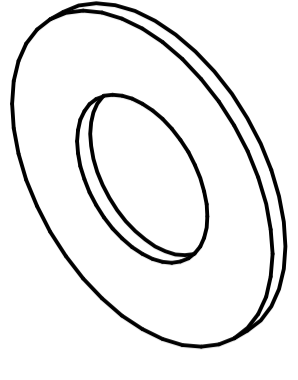
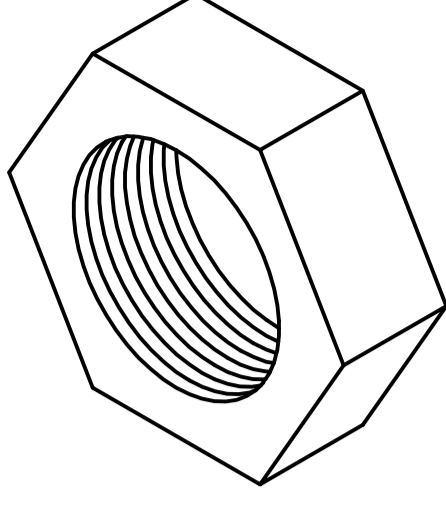
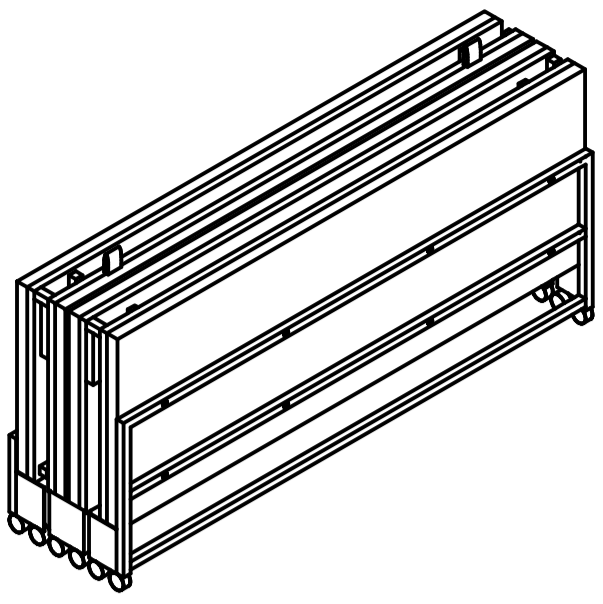
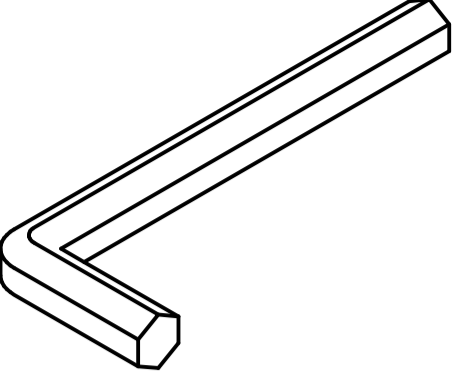
<p>O x 2</p>  <p>Ø 6 x 50 mm</p>	<p>Q x 4</p>  <p>Plastic gasket</p>	<p>S x 2</p> 	<p>N x 1</p> 	<p>U</p> 
---	--	--	--	--

- Refer to the illustration.  
Screw (O) passes through (Q), connects (S) and fixes it.

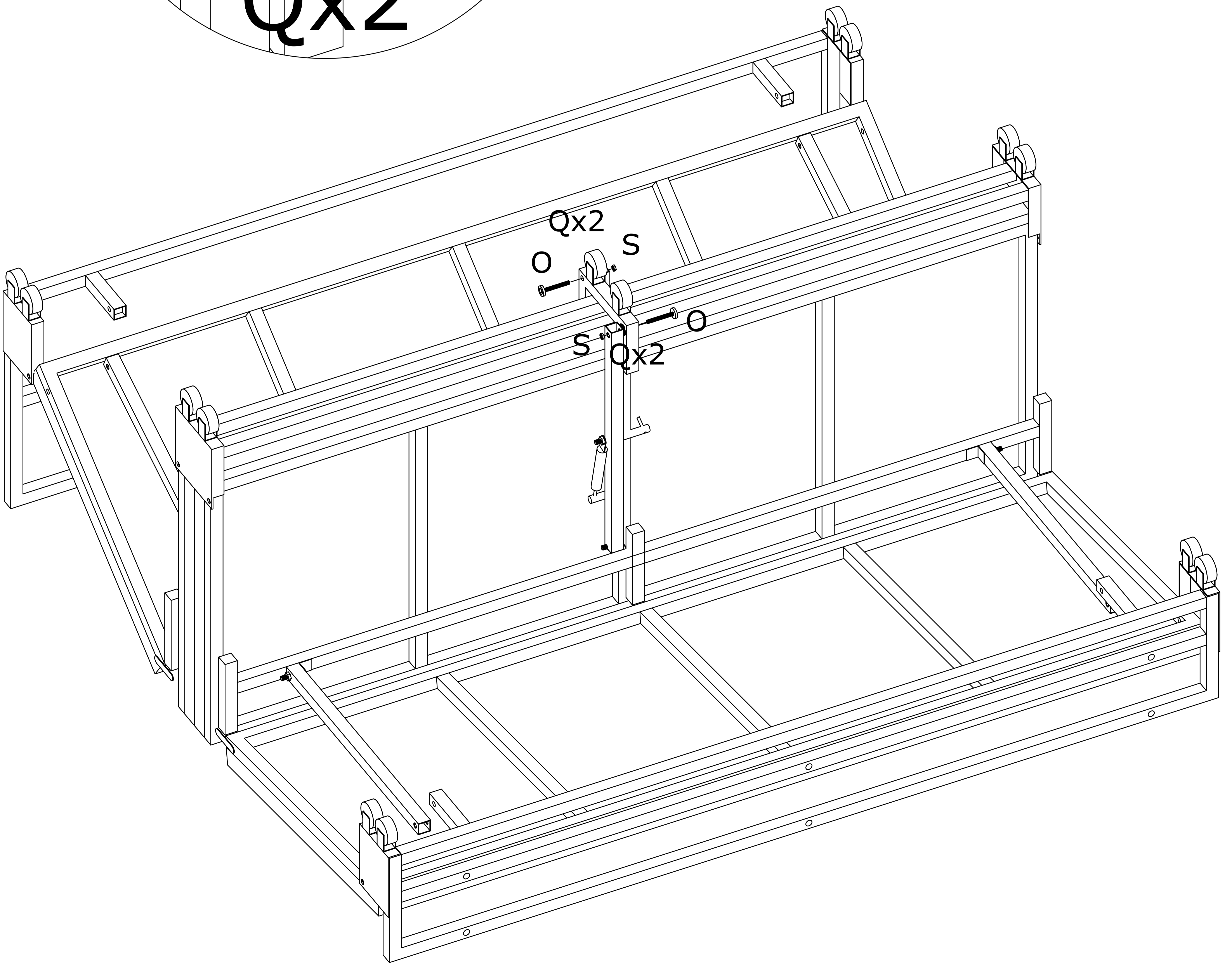
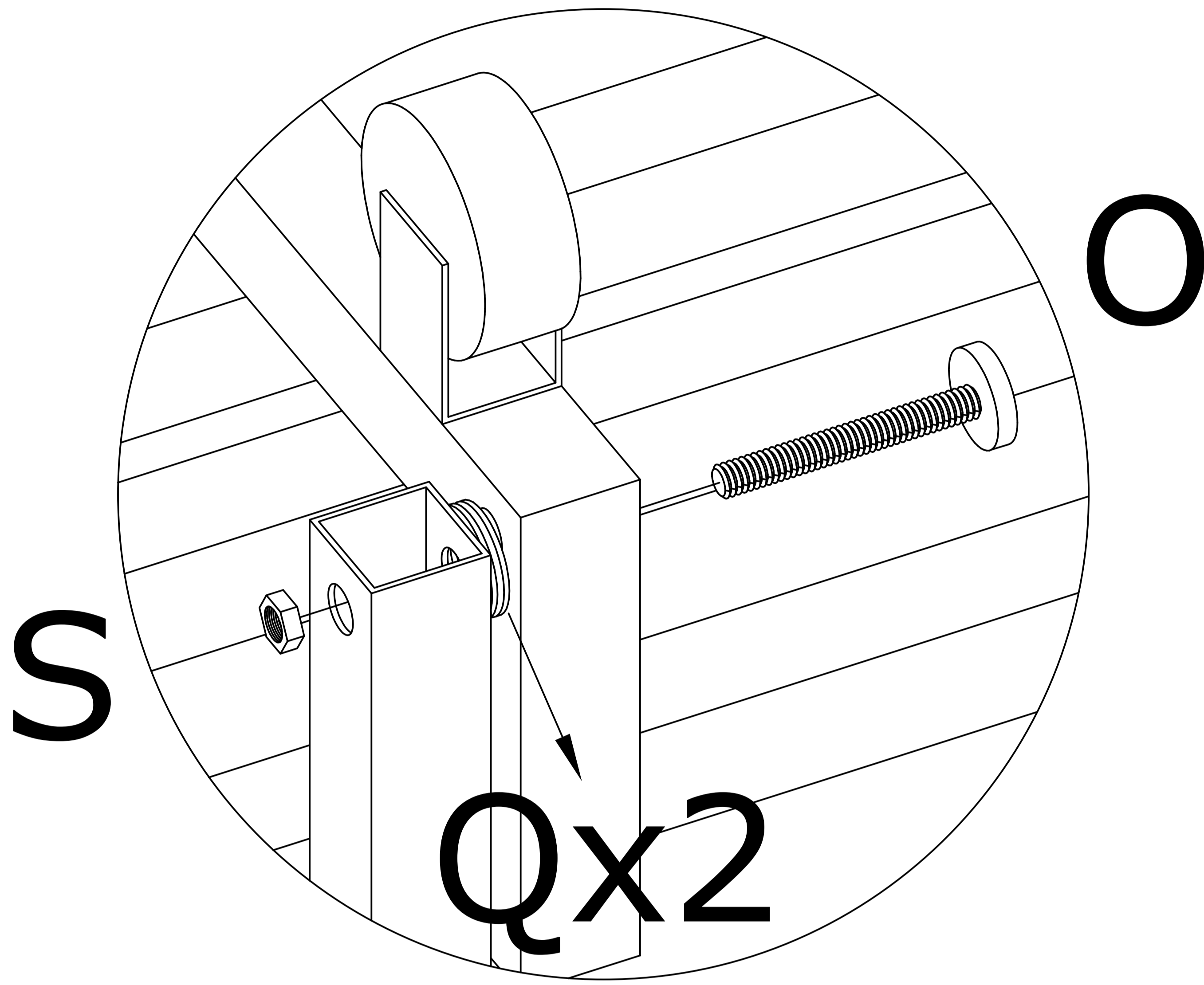
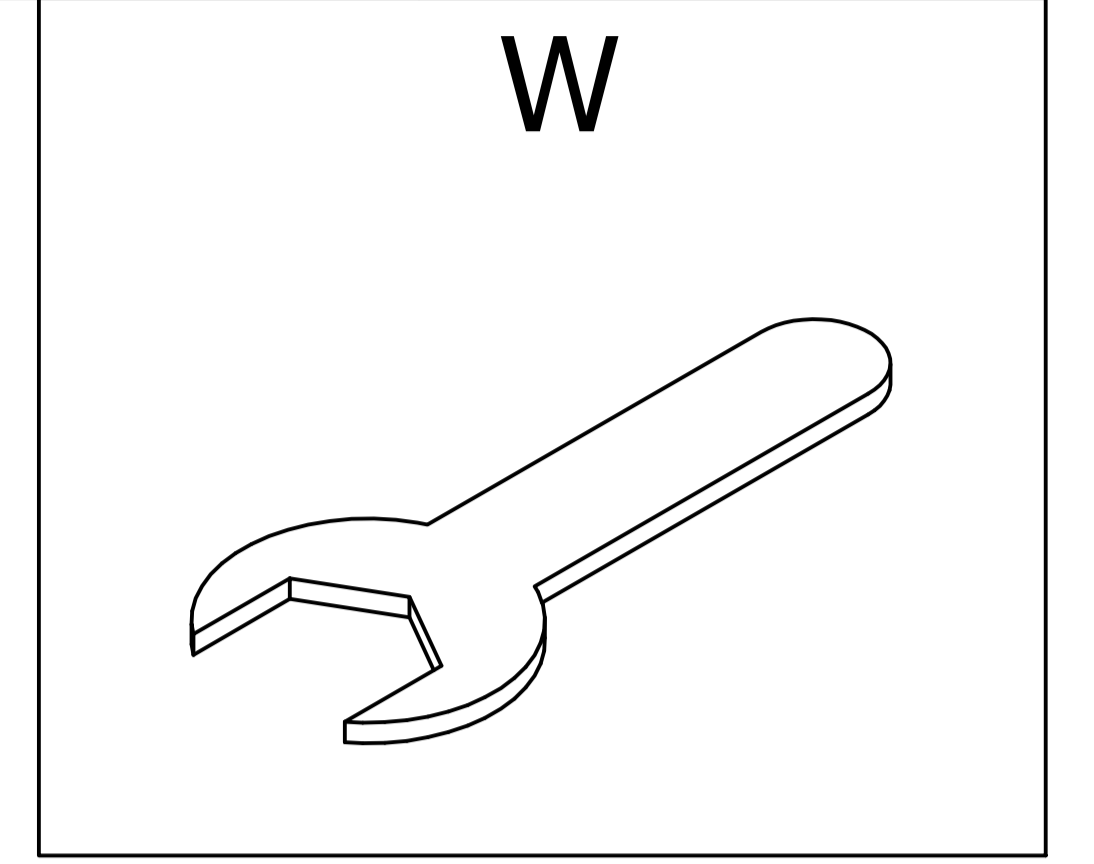

3

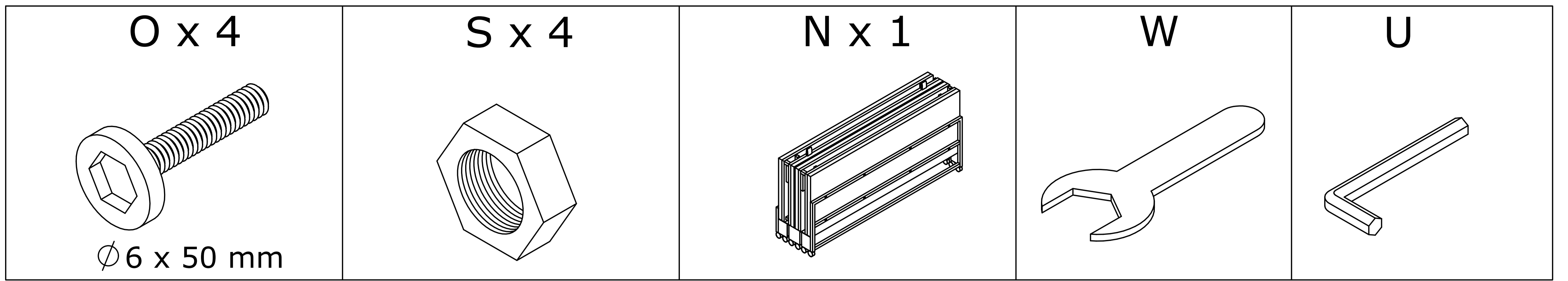

- Refer to the illustration.  
Screw (O) passes through (N) and is connected and fixed to (S).

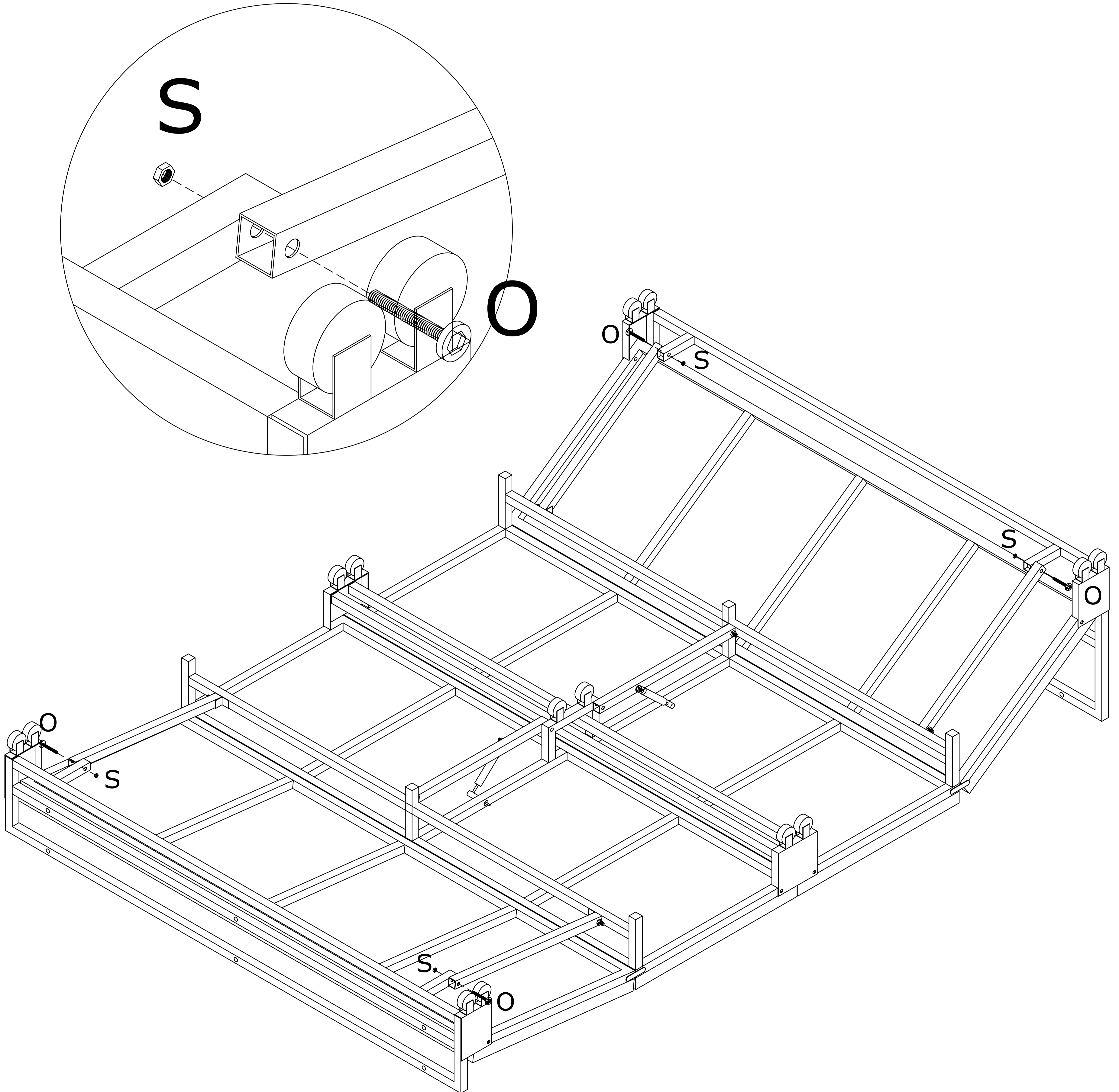

4

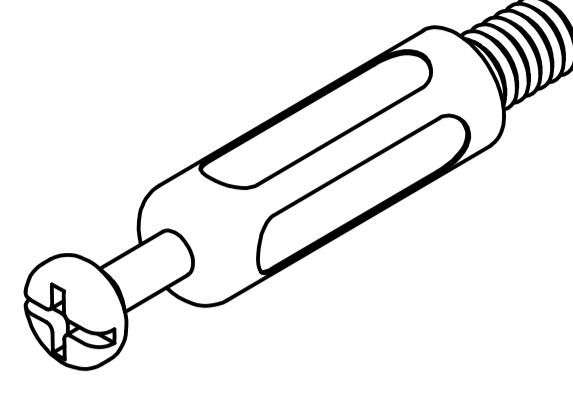
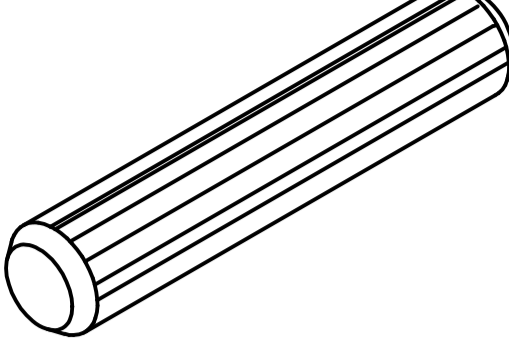
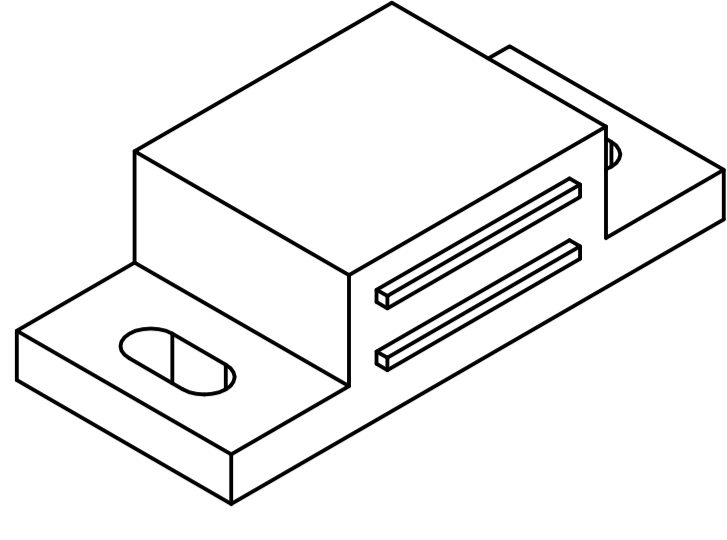
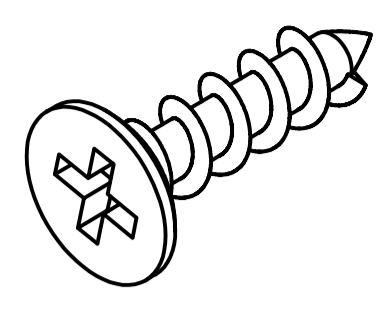
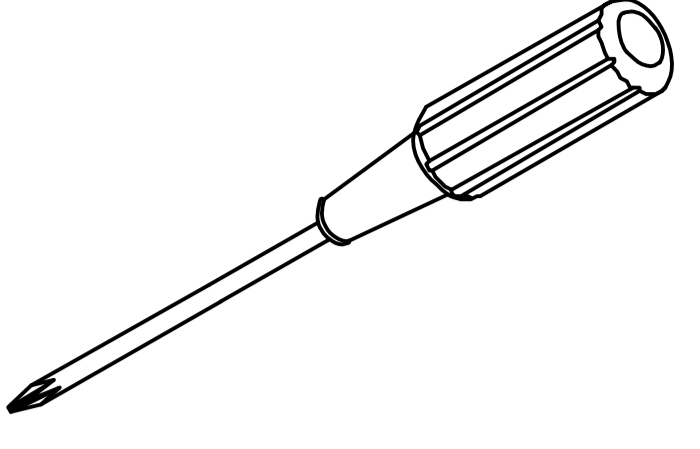
<b>B x 14</b>  Ø 6 x 35 mm	<b>C x 2</b>  Ø 8 x 30 mm	<b>E x 2</b> 	<b>D x 4</b>  Ø 4 x 14 mm	
---	--	---	--	---

- Refer to the illustration.  
Screw (B) into panels (1) and (2),  
fix (E) with screw (D), and insert  
wooden rod (C).

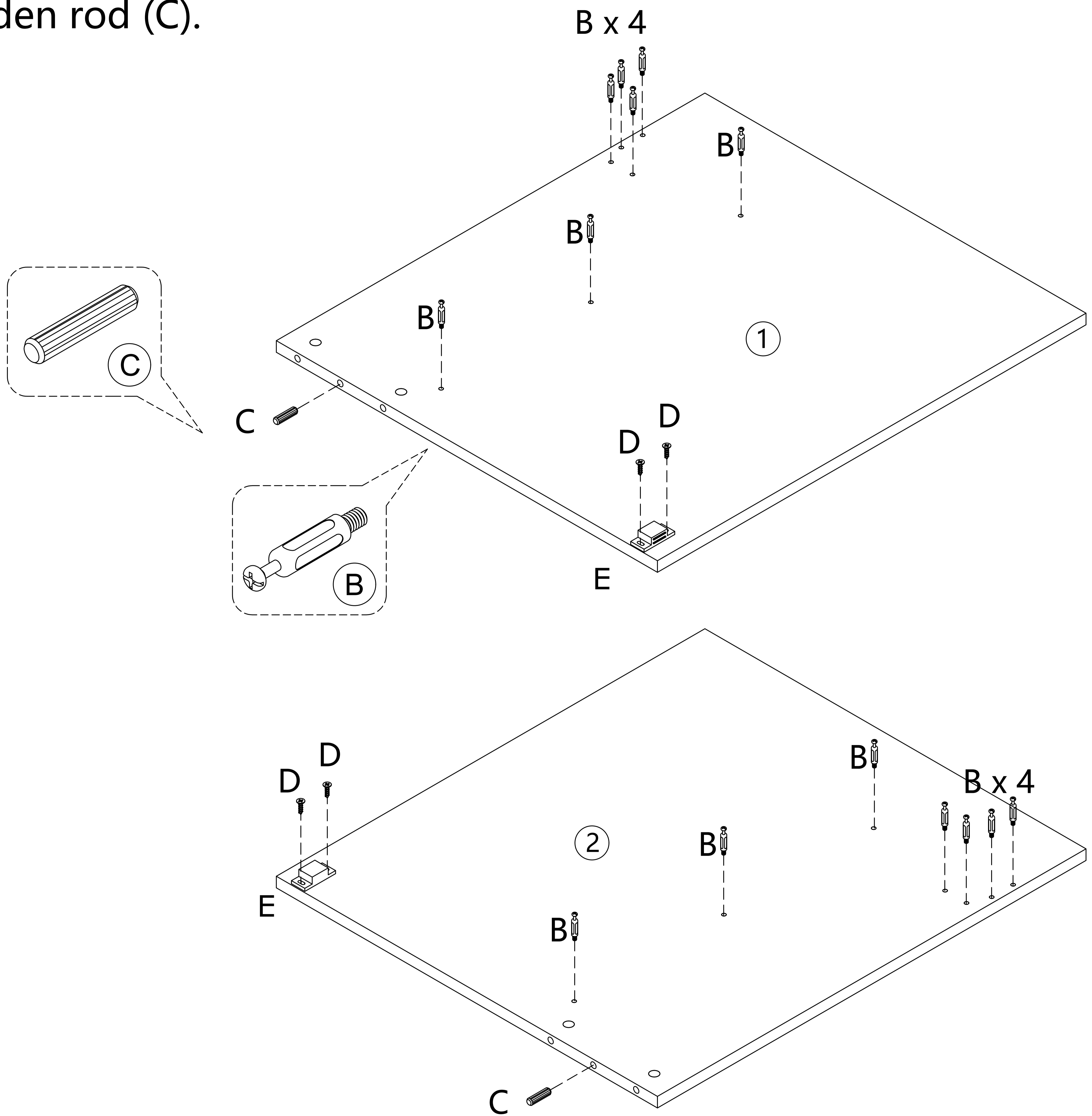

### Reference case images

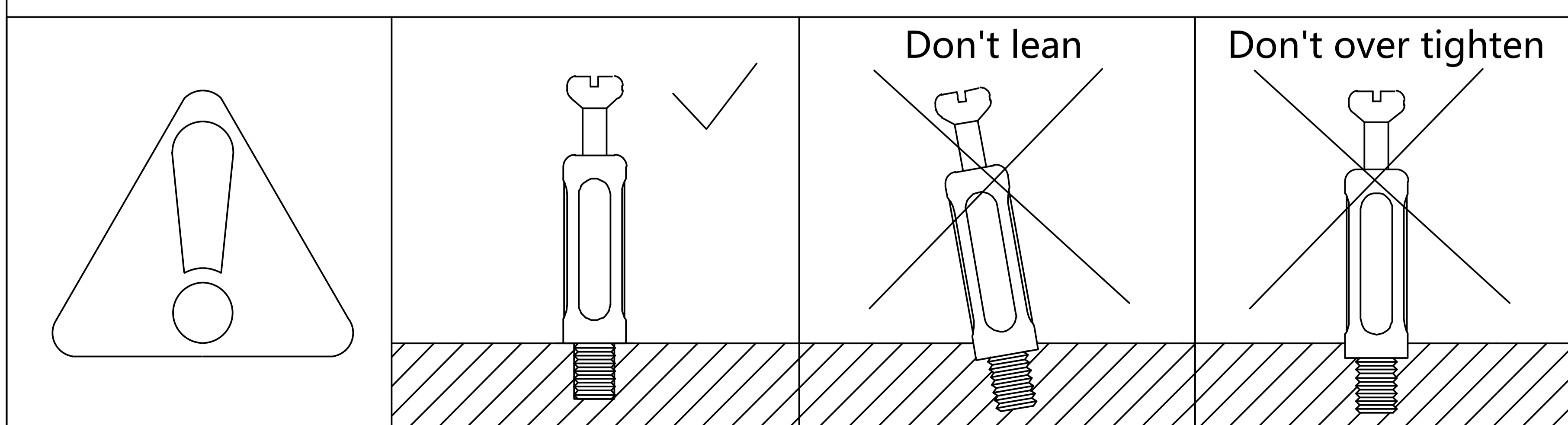

5

<p>A x 2</p>  <p>Ø 12 x 10 mm</p>	<p>B x 2</p>  <p>Ø 6 x 35 mm</p>		
--	---	--	---

- Refer to the illustration.  
Screw (B) into panel (3), flip it 180 degrees, connect it with (4), and tighten the lock catch (A).

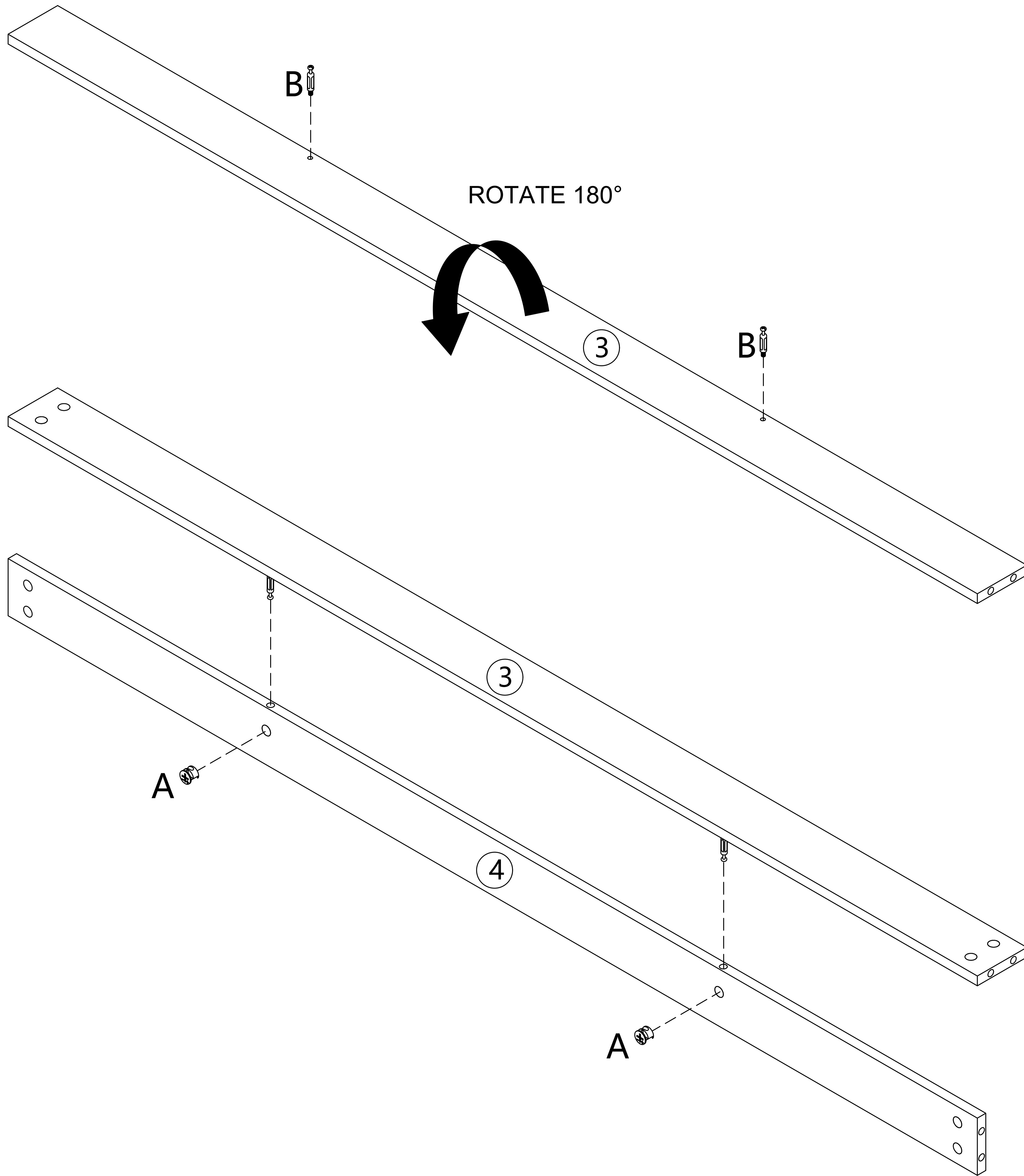

### Reference case images

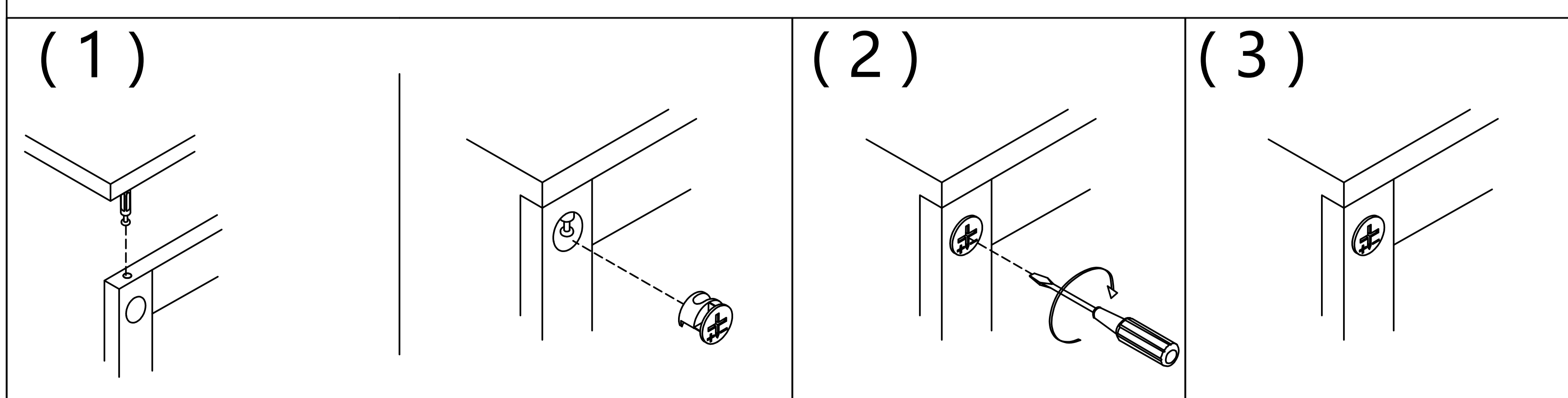

6

A x 14

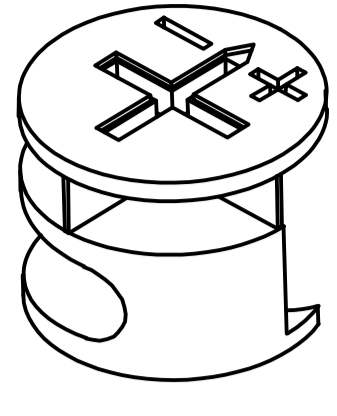

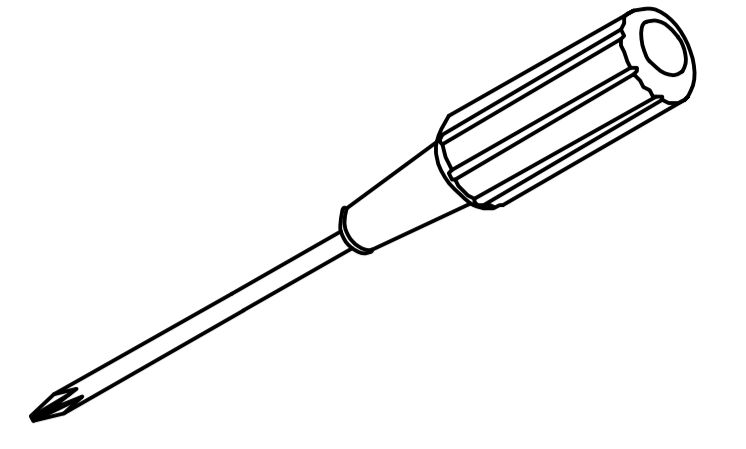

Ø 12 x 10 mm

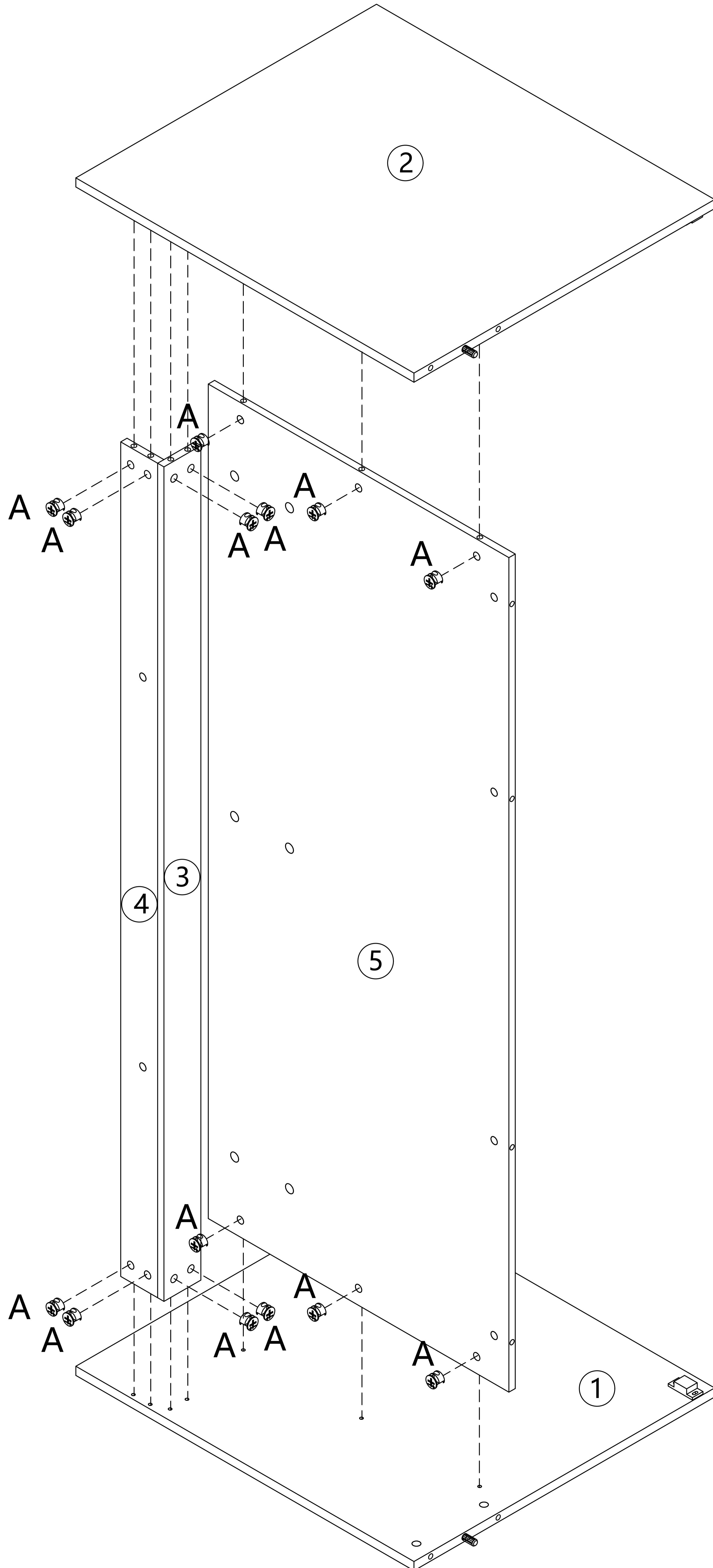

- Refer to the illustration.  
Connect (1), (2) with (3), (4), (5), and tighten the lock catch (A).

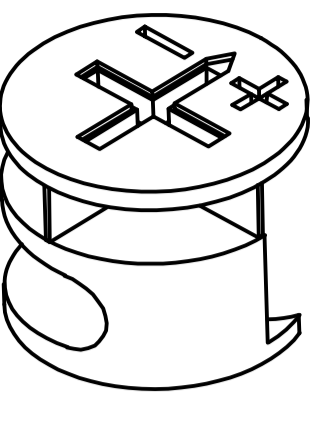
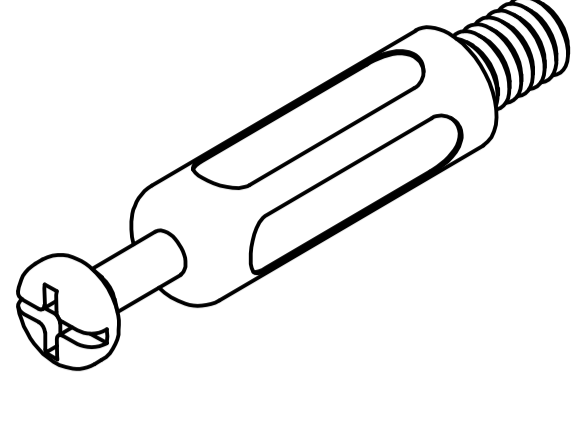
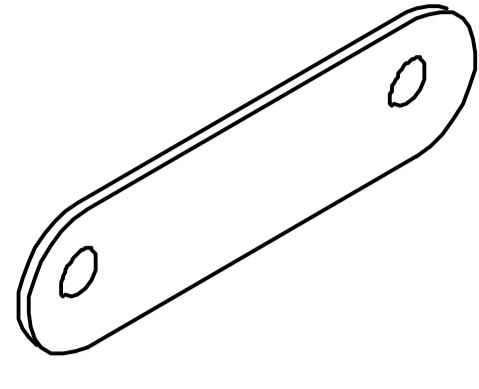
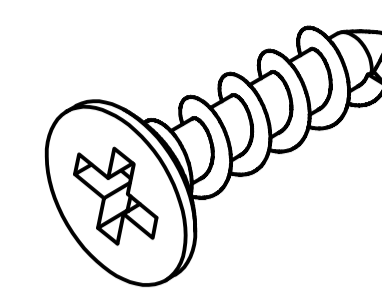

7

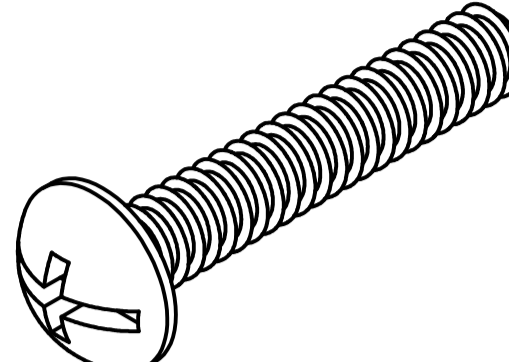
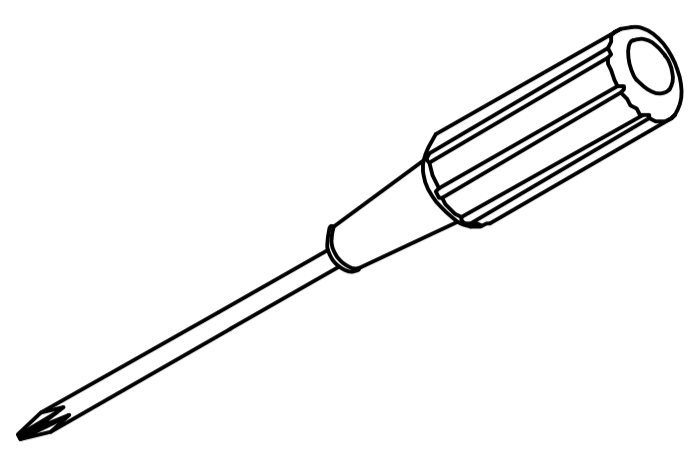
<b>F x 4</b>  Ø 15 x 12 mm	<b>B x 4</b>  Ø 6 x 35 mm	<b>G x 2</b> 	<b>D x 4</b>  Ø 4 x 14 mm	
		<b>J x 2</b> 	<b>K x 4</b>  Ø 4 x 19 mm	

- Refer to the illustration. Screw (B) into panel (6), connect it with (7), tighten the lock catch (A), fix (G) with screw (D), and fix (J) with screw (K).

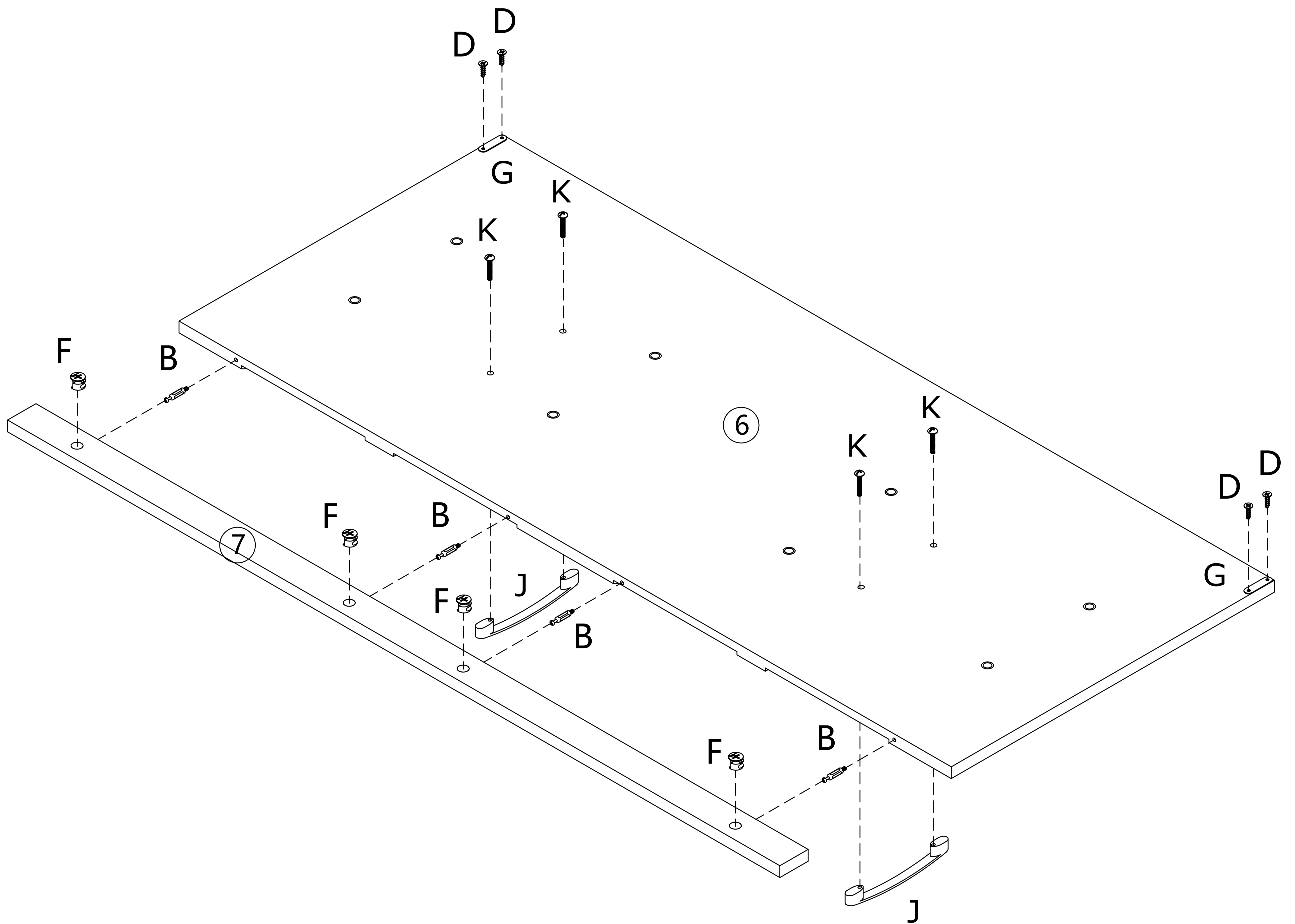

### Reference case images

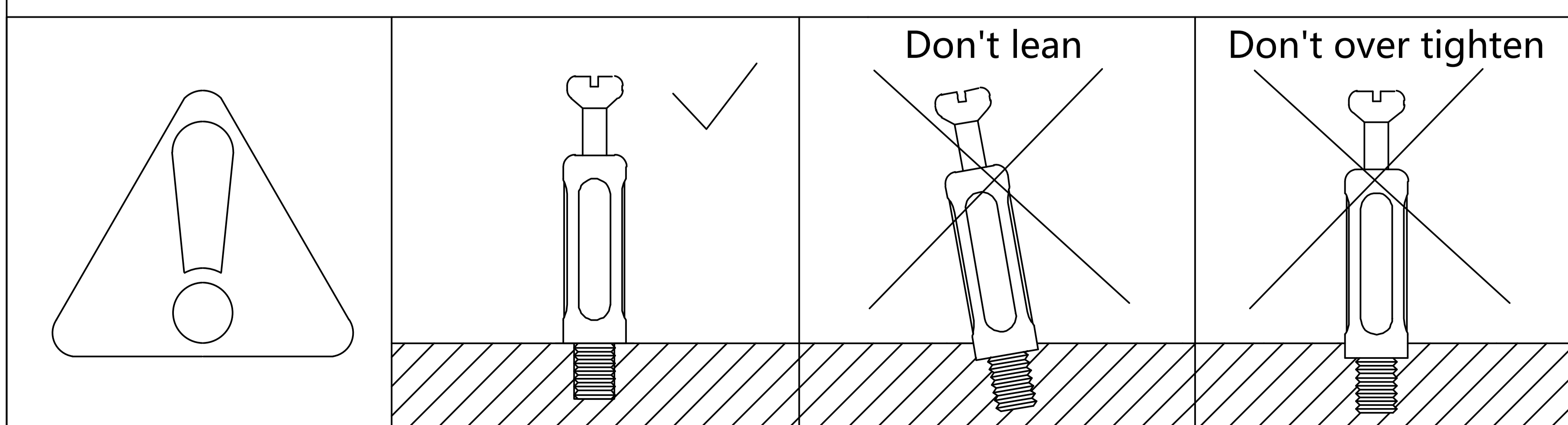

8

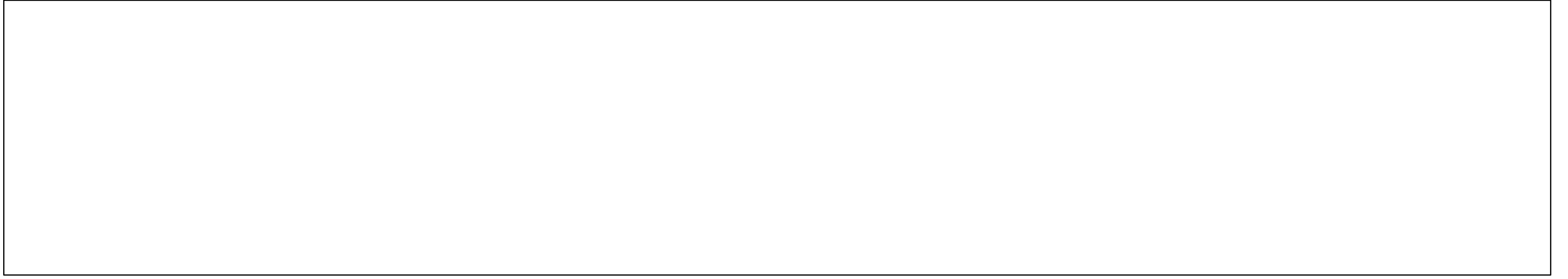

- Refer to the illustration.  
Paste and connect (T) and (5).

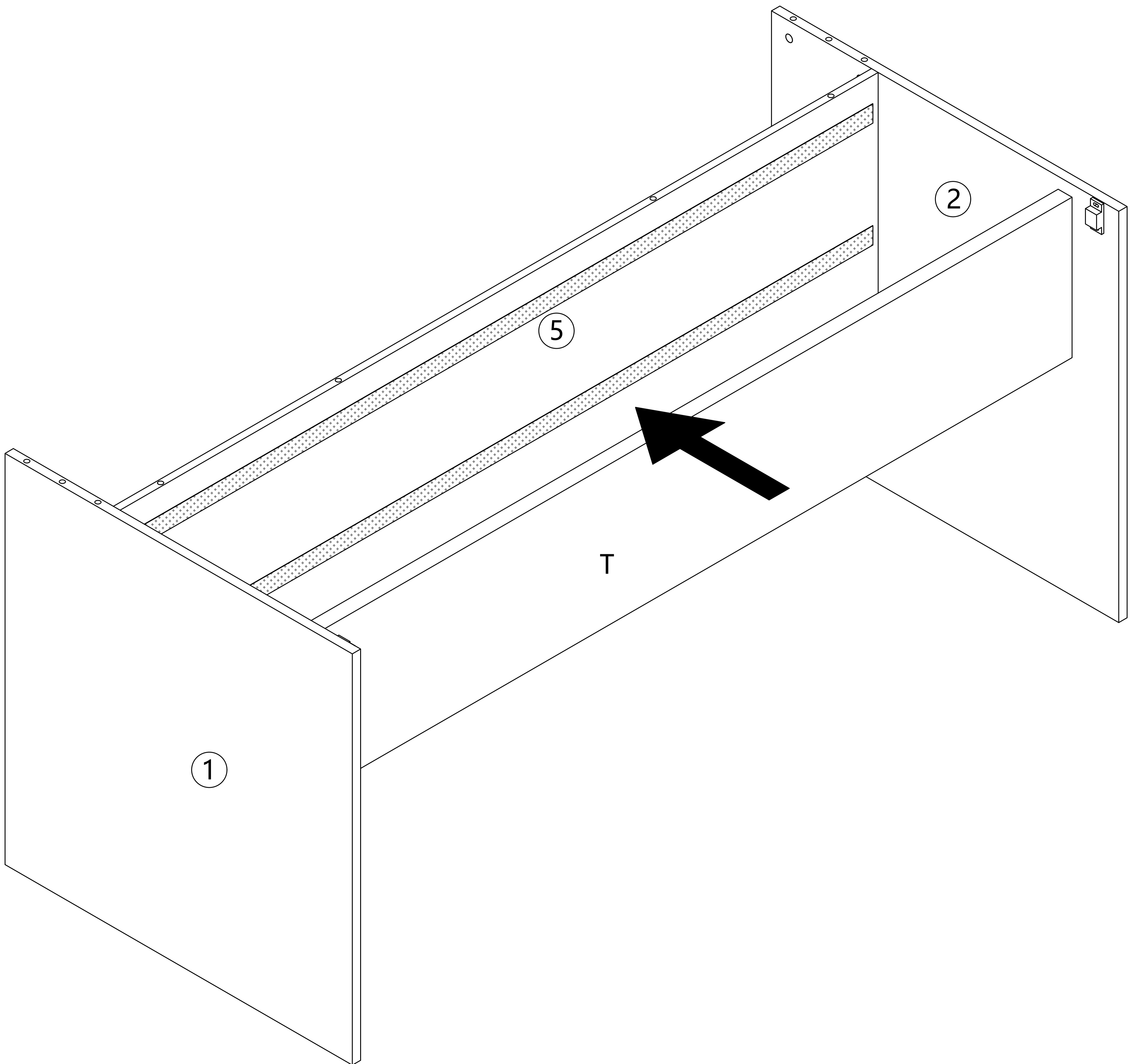

9



- Refer to the illustration.  
Connect the folding bed (N) to (5) and fix it with screws (H).

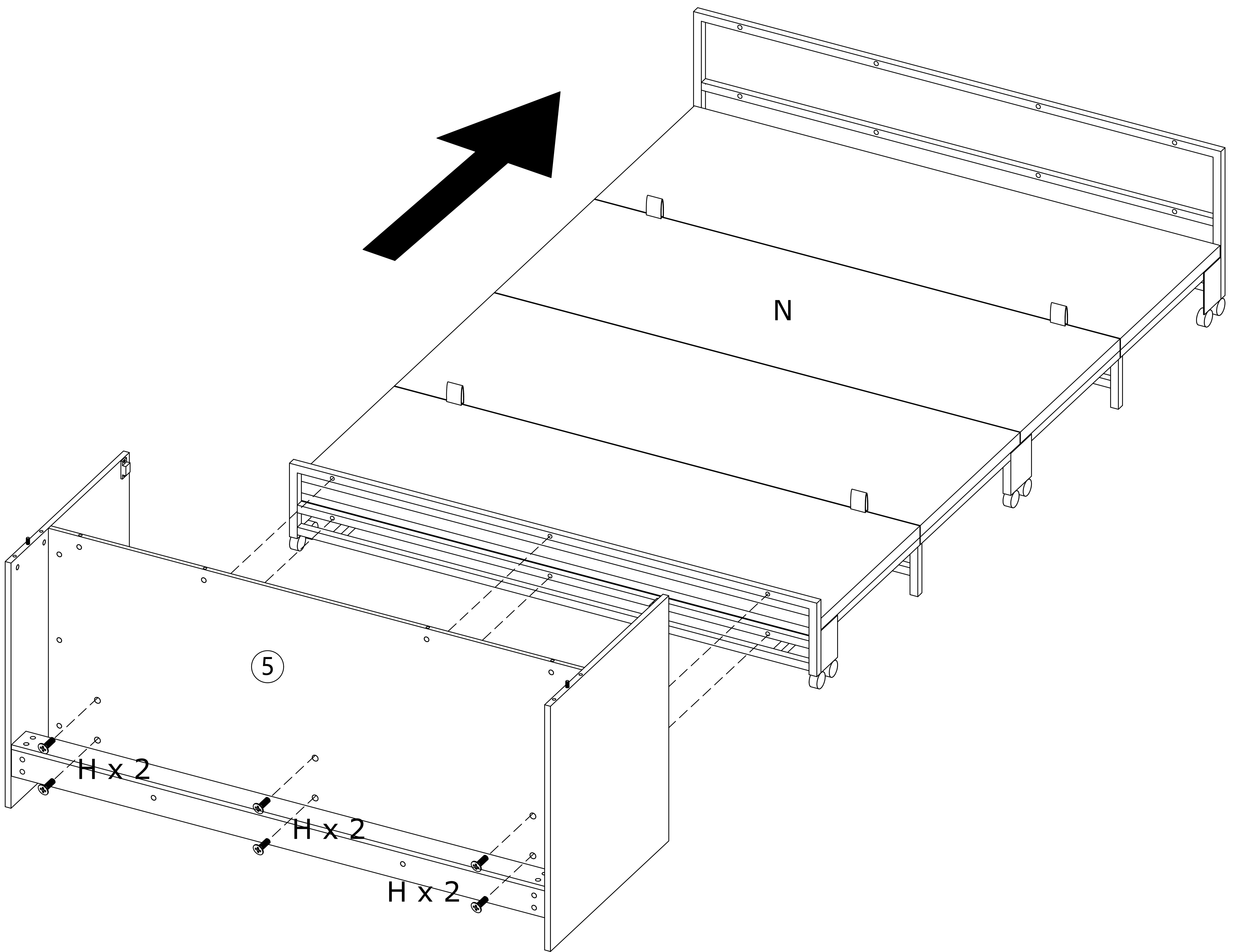

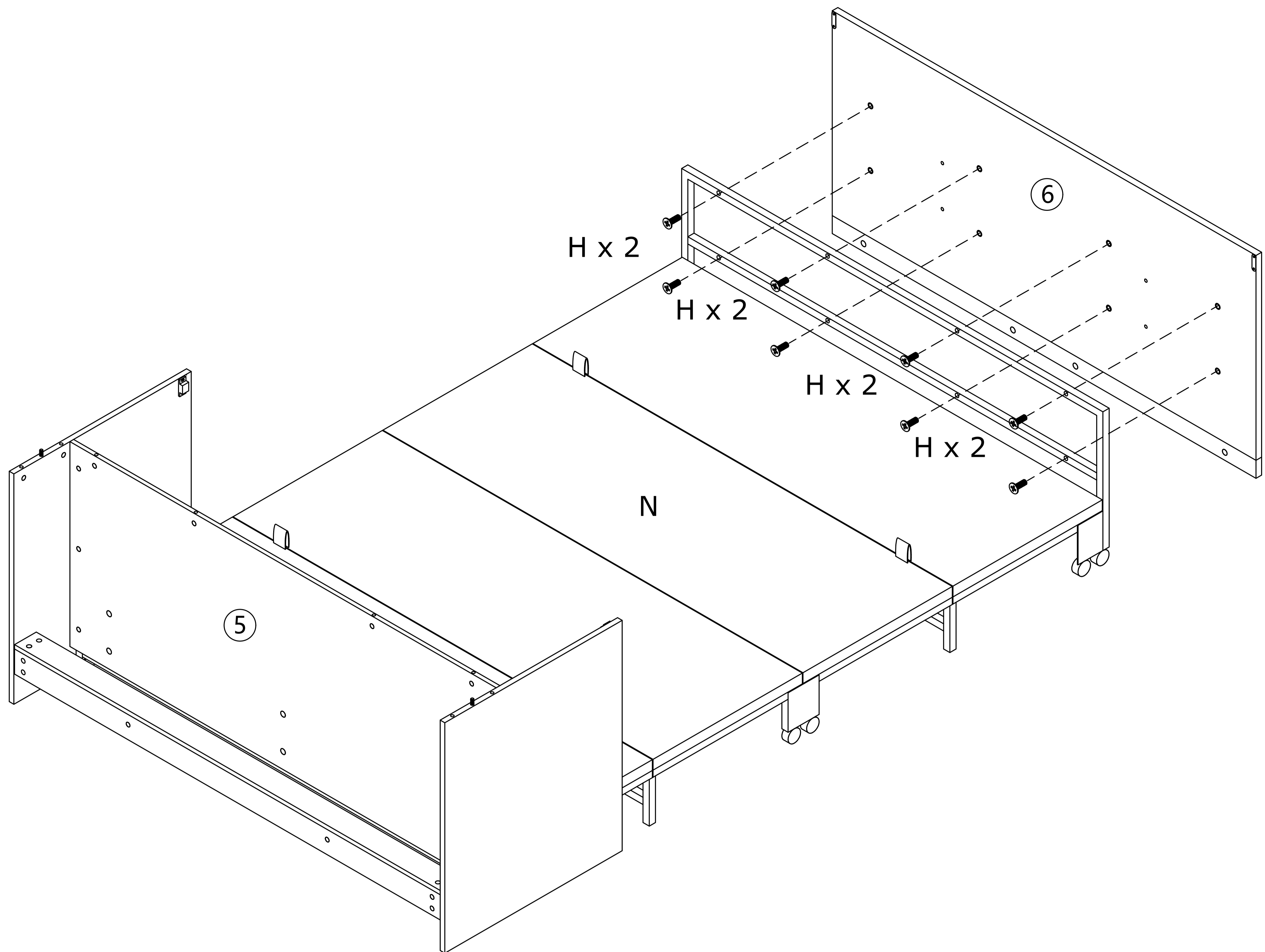

## Installation Notes

1.Special Instructions for Step 10: During installation, first screw all screws of type H into their corresponding holes one by one (note: do not fully tighten them at this point). After all screws have been successfully inserted into the holes, then tighten them uniformly to secure.

2.Tips for Fitting Metal Parts: Due to normal dimensional tolerances within a certain range for metal parts, if you encounter slight fitting issues during installation, please adjust patiently before proceeding to ensure a secure installation.



12

A x 8

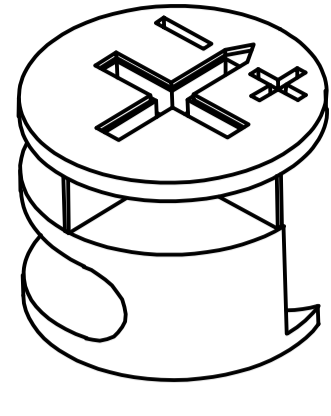

Ø 12 x 10 mm

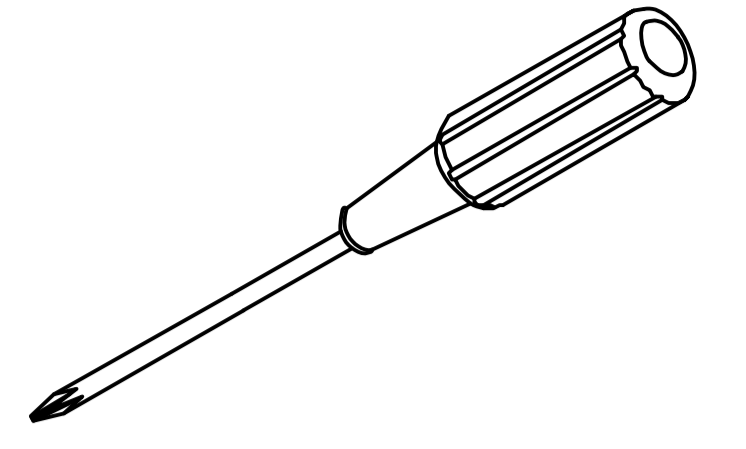

- Refer to the illustration.  
Connect (1), (2), (5) with (8) and tighten the lock catch (A).

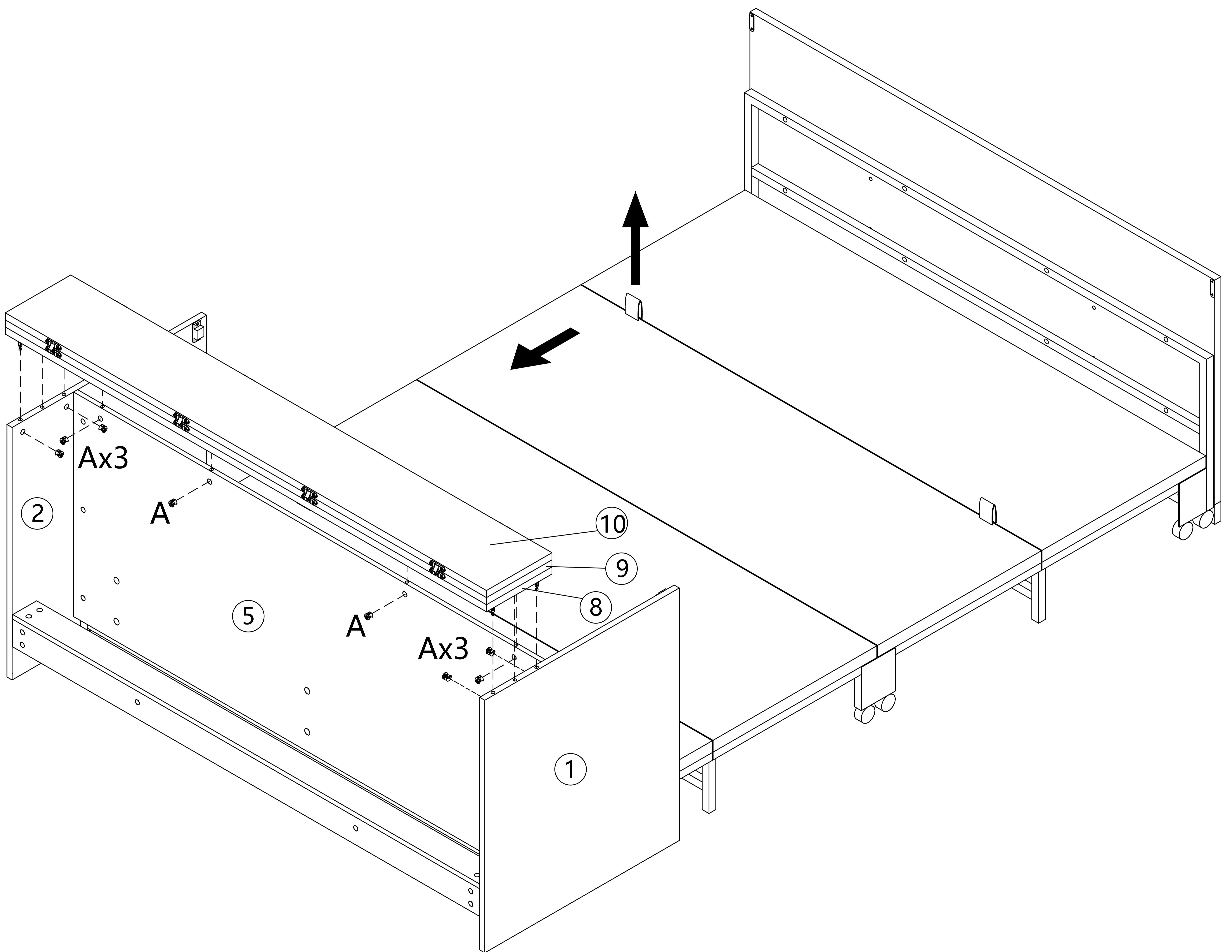

13

- Refer to the illustration.  
Flip panels (8) and (9).

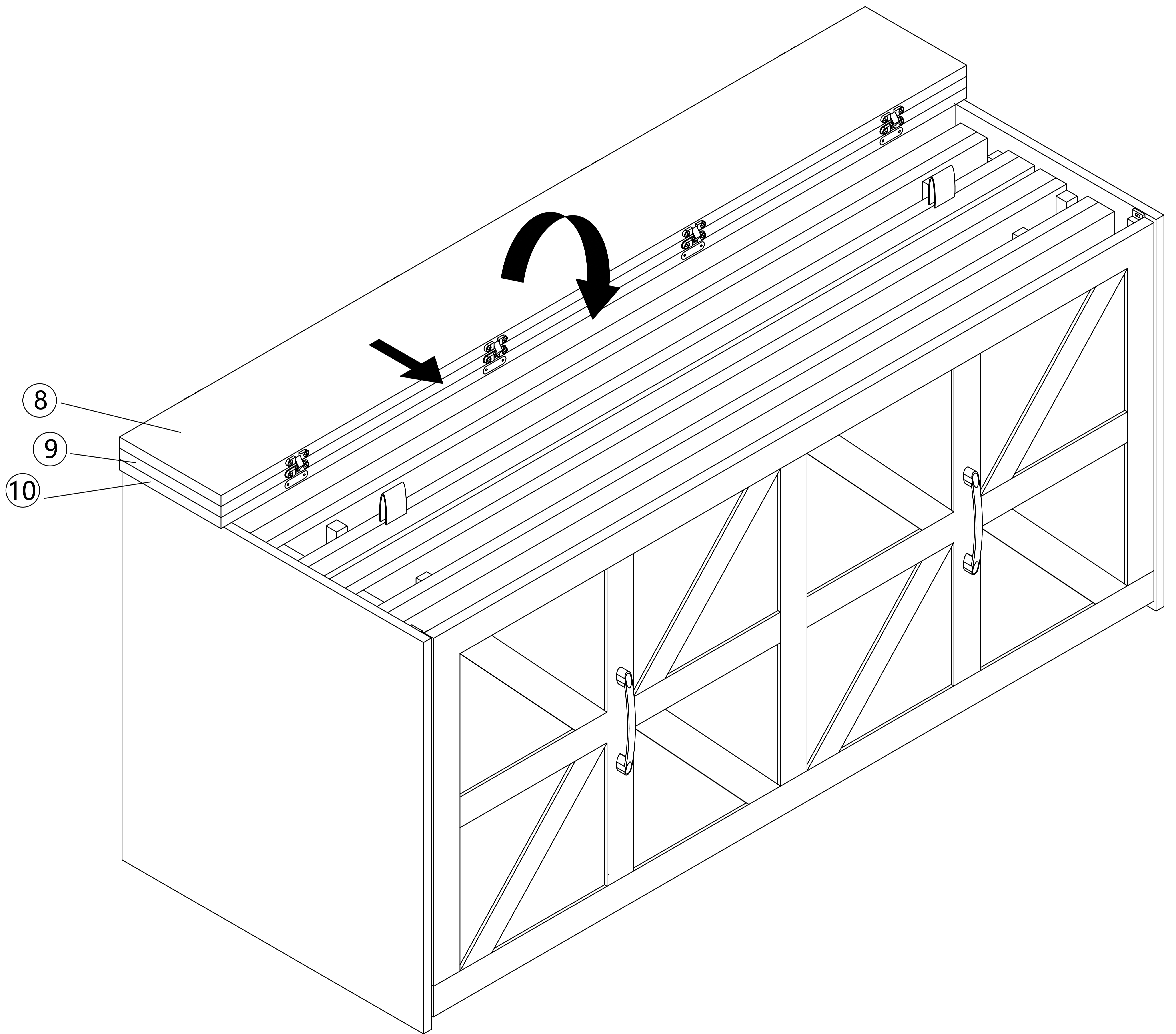

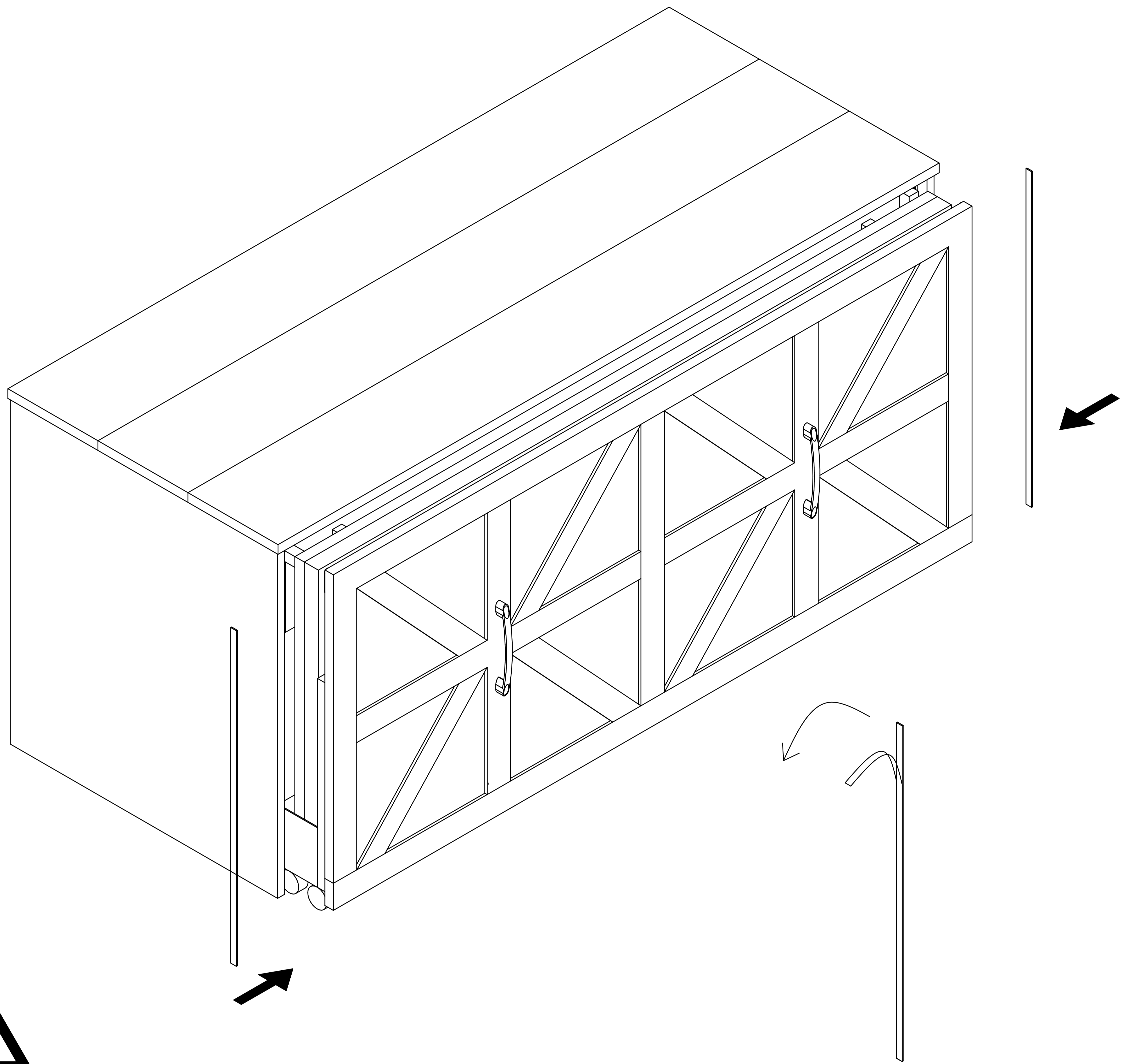

### Steps for Installing the Seal Strip

1. After the cabinet is fully assembled, take out the seal strip.
2. Peel off the protective paper from the adhesive layer on the back of the seal strip.
3. Accurately stick the treated seal strip to the designated position on the side of the door panel.

Note: Ensure the side of the door panel is clean and dry before installation to guarantee a firm bond.

14

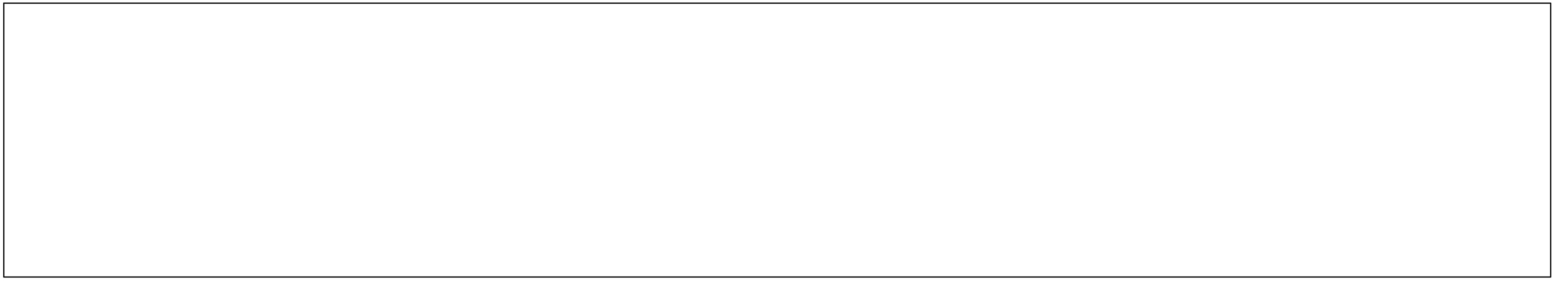

-Installation complete.

