

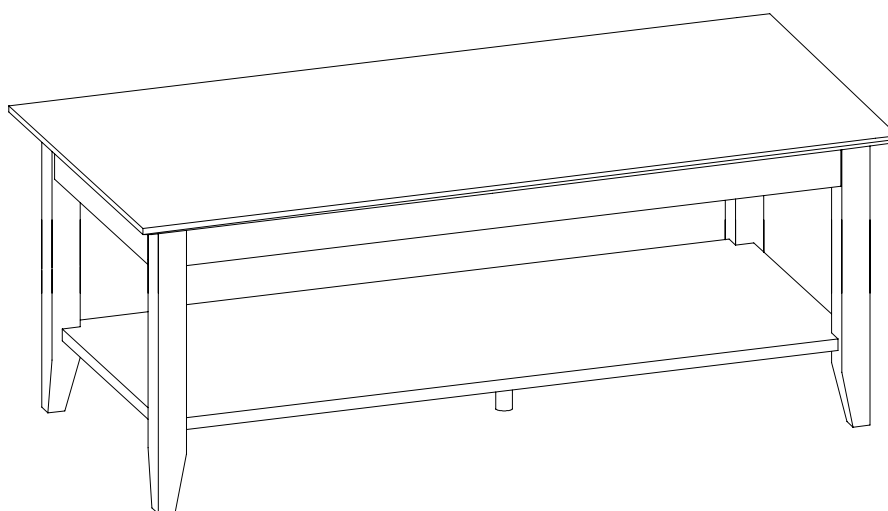

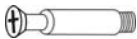







# COFFEE TABLE WITH SHELF

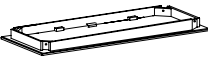

## HARDWARE LIST

CODE	NAME	FIGURE	Q'TY
A	CAM BOLTS ( 6.5*35mmL )		4PCS
B	CAM LOCKS ( Ø15x9mm )		4PCS
C	ALLEN SCREW ( Ø1/4*45mmL )		4PCS
D	WASHER ( Ø1/4*16mmL )		4PCS
E	LOCK WASHER (Ø1/4*11*1.5mmL)		4PCS
F	ALLEN WRENCH ( 4*21*57mmL )		1PC

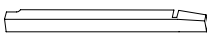
## PARTS LIST

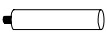
CODE	NAME	FIGURE	Q'TY
1	TOP PANEL		1PC
2	BOTTOM PANEL		1PC
3	LEG		4PCS
4	COLOR STICK		1PC
5	BOTTOM LEG		1PC



Please do not return to the store  
 . Broken or Missing Parts?  
 . Need help with Assembly?

1. SCREW CAMBOLTS (A) INTO LEGS (3) AND PLACE CAMLOCKS (B) INTO BOTTOM PANEL (2).

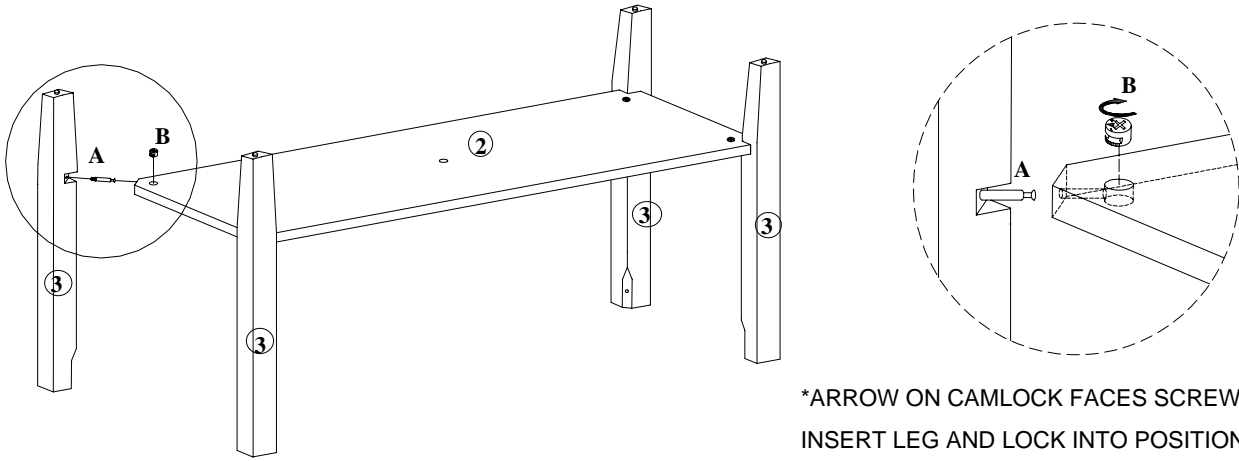

\*ARROW ON CAMLOCK FACES SCREW HOLE  
INSERT LEG AND LOCK INTO POSITION  
BY TURNING CAMLOCK CLOCKWISE

HARDWARE  
NEEDED

A x 4
B x 4

**STEP 1**

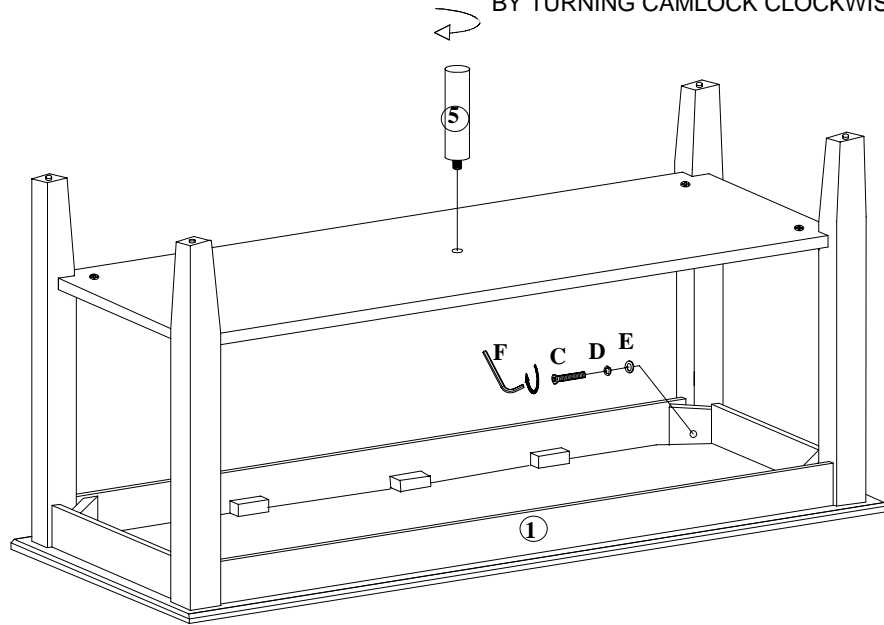

2. PLACE LEG ASSEMBLY ONTO TOP (1) AND FASTEN WITH ALLEN SCREWS (C) AND WASHERS (D) AND (E).

HARDWARE  
NEEDED

C x 4
D x 4
E x 4
F x 1

**STEP 2**

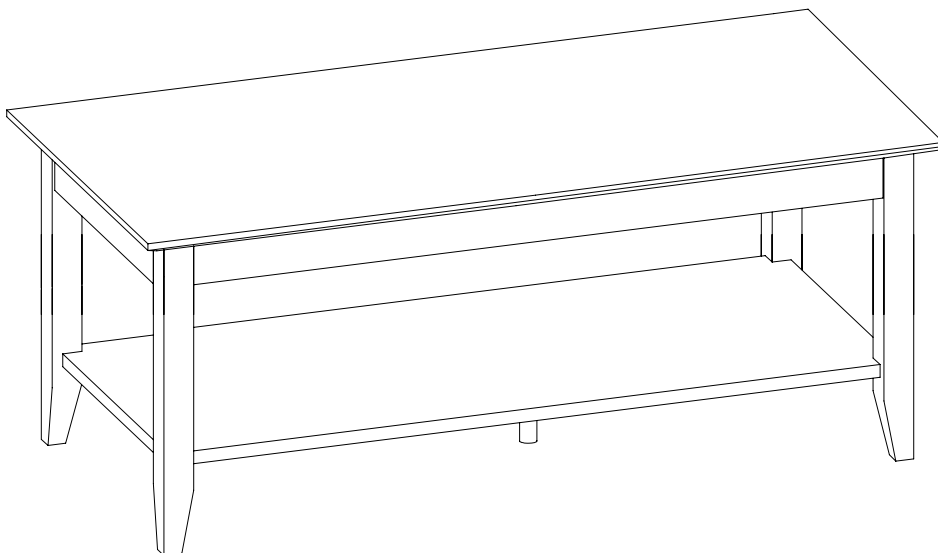

**STEP 3**