

# *ASSEMBLY INSTRUCTIONS*



# ASSEMBLY INSTRUCTIONS

## ASSEMBLY TIPS:

1. Remove hardware from box and sort by size.
2. Please check to see that all hardware and parts are present prior to start of assembly.
3. Please follow attached instructions in the same sequence as numbered to assure fast & easy assembly.



### WARNING!

1. Don't attempt to repair or modify parts that are broken or defective. Please contact the store immediately.
2. This product is for home use only and not intended for commercial establishments.



ASSEMBLY TIME

20 MINUTES

## PARTS IDENTIFICATION

### B1 ( BOX 1 )

A HEADBOARD PANEL

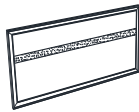

1PC

B FOOTBOARD

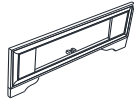

1PC

C RIGHT HEADBOARD LEG

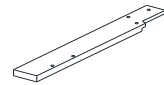

1PC

D LEFT HEADBOARD LEG

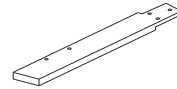

1PC

### B2 ( BOX 2 )

E BED RAIL

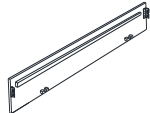

2PCS

F CONCEAL PANEL



3PCS

G BED SLAT



3PCS

G2 BED SLAT WITH STOPPER

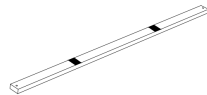

2PCS

H DRAWER BOTTOM TRESTLE BAR

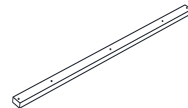

1PC

I DRAWER SUPPORT RAIL



1PC

J DRAWER SUPPORT LEG WITH LEVELER



1PC

### B3 ( BOX 3 )

K DRAWER BOX

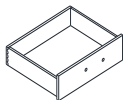

1PC

HB 205111T(B1) FROM BOX 1 HEADBOARD COMPLETE



1PC

B 205111T(B1) FROM BOX 1 FOOTBOARD

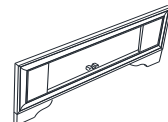

1PC

# ASSEMBLY INSTRUCTIONS

## ASSEMBLY TIPS:

1. Remove hardware from box and sort by size.
2. Please check to see that all hardware and parts are present prior to start of assembly.
3. Please follow attached instructions in the same sequence as numbered to assure fast & easy assembly.







## WARNING!









1. Don't attempt to repair or modify parts that are broken or defective. Please contact the store immediately.
2. This product is for home use only and not intended for commercial establishments.

## HARDWARE IDENTIFICATION

### Z-B1 (BOX 1) - HARDWARE PACK IS LOCATED IN 205111T (B1)

|   |                                    |   |      |   |   |   |      |
|---|------------------------------------|---|------|---|---|---|------|
| 1 | <b>BOLT</b><br>(M6 x 30mm - BLK)   |  | 6PCS | 3 | <b>FLAT WASHER</b><br>(1/4"ID x 13mm - BLK) |  | 6PCS |
| 2 | <b>LOCK WASHER</b><br>(1/4" - BLK) |  | 6PCS | 4 | <b>ALLEN WRENCH</b><br>(M4 x 60mm - BLK)    |  | 1PC  |

### Z-B2 (BOX 2) - HARDWARE PACK IS LOCATED IN 205111T (B2)

|   |  |   |       |    |  |   |     |
|---|--|---|-------|----|--|---|-----|
| 5 | <b>FLAT HEAD SCREW</b><br>(M4 x 32mm - RBW)  |  | 13PCS | 9  | <b>LOCK WASHER</b><br>(1/4" - BLK)             |  | 1PC |
| 6 | <b>PAN HEAD SCREW</b><br>(M3.5 x 20mm - BLK) |  | 15PCS | 10 | <b>FLAT WASHER</b><br>(1/4"ID x 13mm - BLK)    |  | 1PC |
| 7 | <b>SHORT BOLT</b><br>(M6 x 35mm - BLK)       |  | 1PC   | 11 | <b>SMALL ALLEN WRENCH</b><br>(M4 x 60mm - BLK) |  | 1PC |
| 8 | <b>LONG BOLT</b><br>(M6 x 50mm - BLK)        |  | 1PC   | 12 | <b>BIG ALLEN WRENCH</b><br>(M5 x 65mm - BLK)   |  | 1PC |

## NOTE:

Phillips head screw driver is required in the assembly process; however, manufacturer does not provide this item.

# ASSEMBLY INSTRUCTIONS

## STEP 1

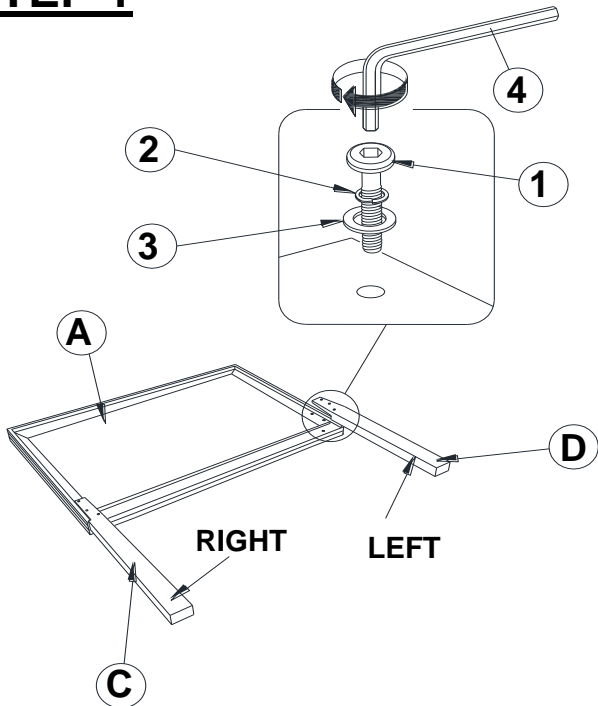

**\*\*BACK VIEW\*\***

Note : Please take note of the marking sticker (L&R) on the leg.

## STEP 2

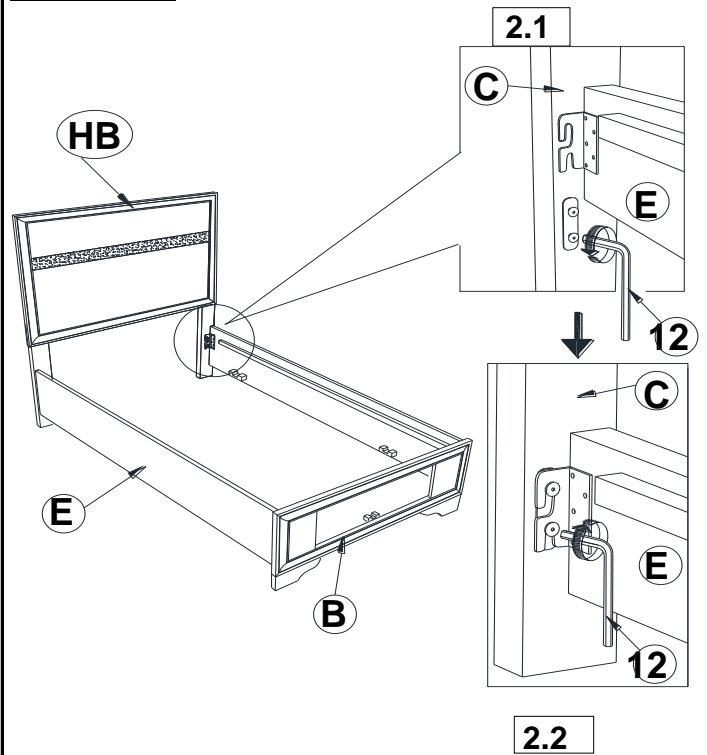

## STEP 3

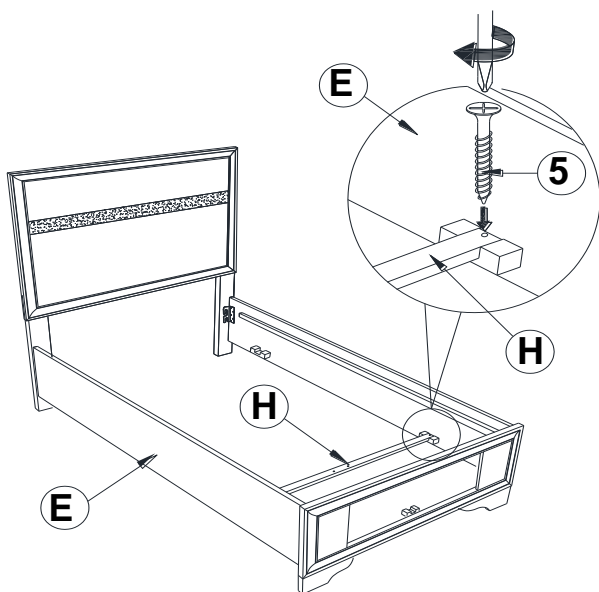

## STEP 4

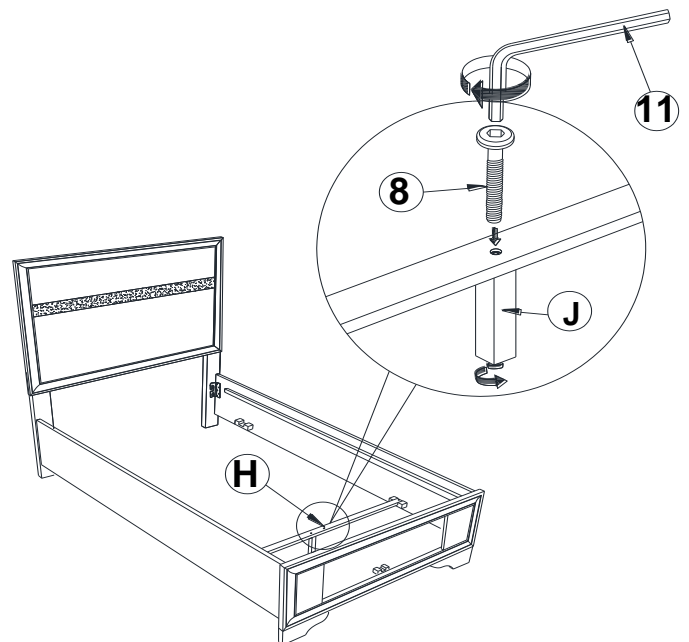

# ASSEMBLY INSTRUCTIONS

## STEP 5

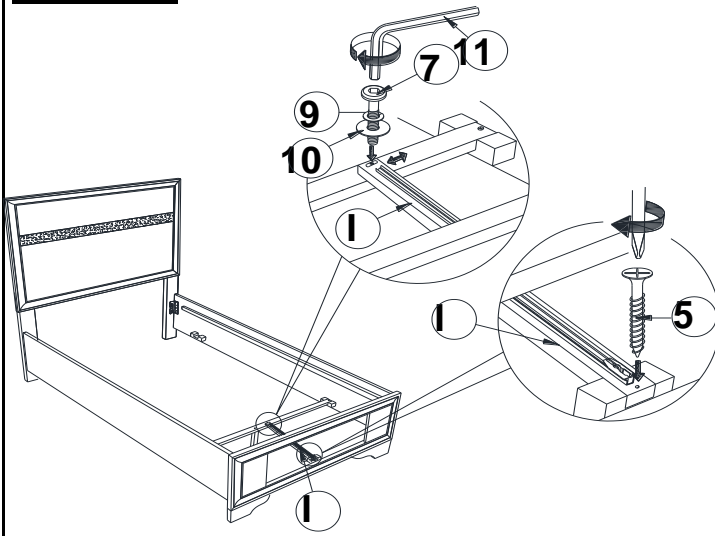

## STEP 6

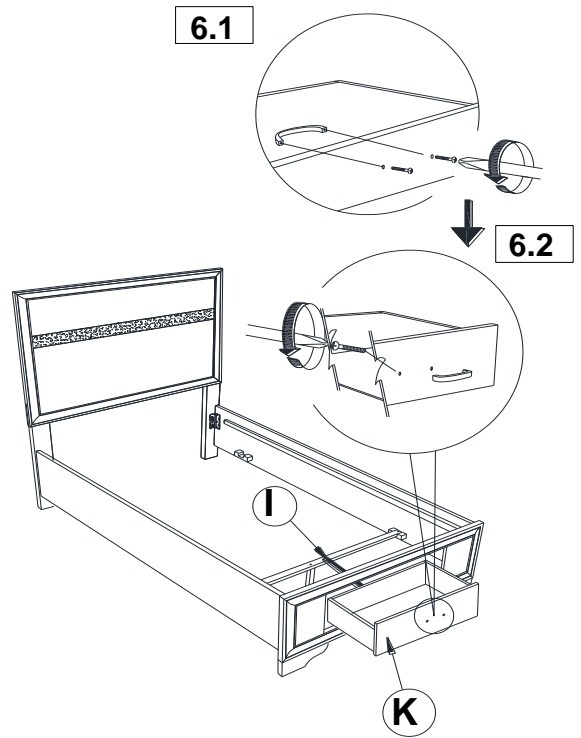

## STEP 7

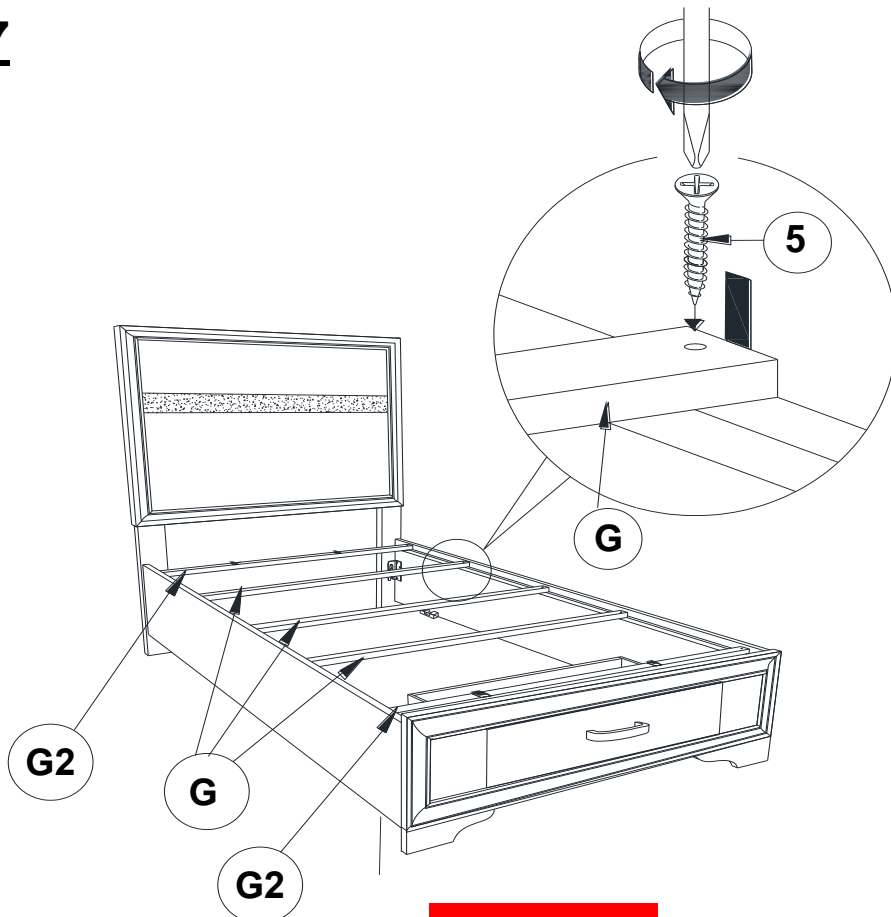

# ASSEMBLY INSTRUCTIONS

## STEP 8

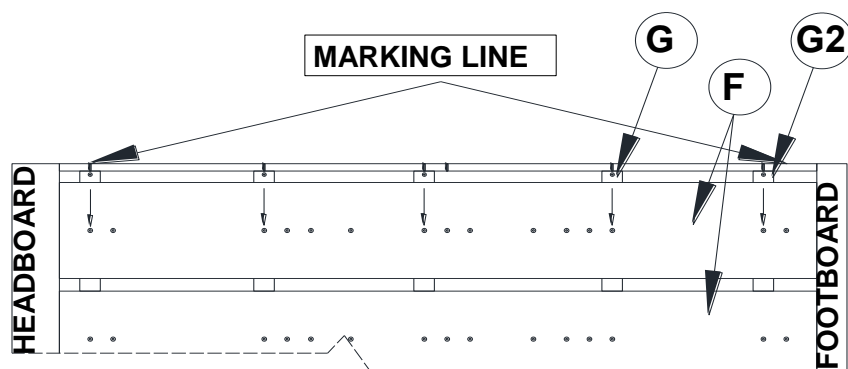

TIGHTEN THE PANHEAD SCREW (6) BY FOLLOW THE ARROW AS SHOWN

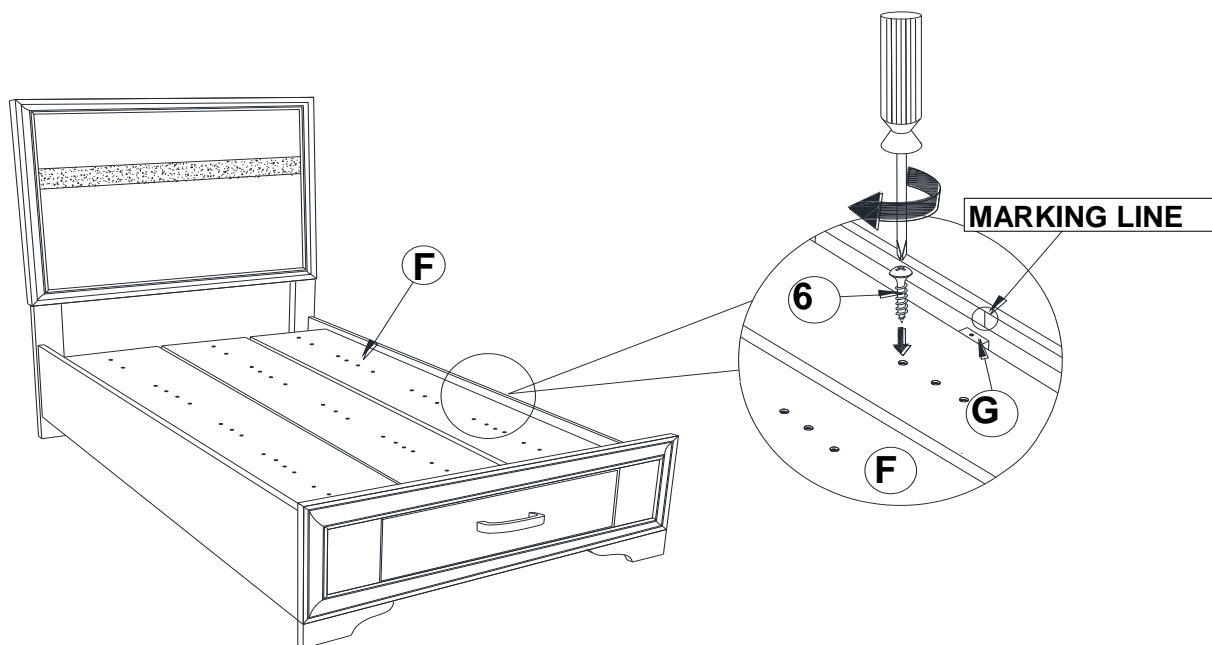

## STEP 9

## COMPLETE

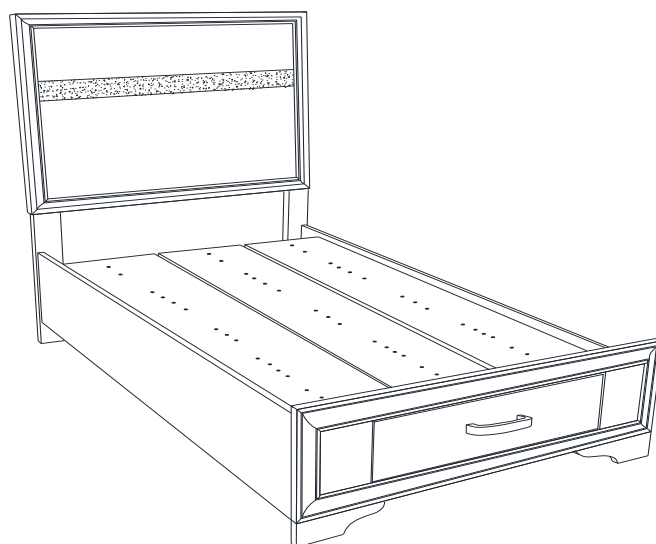

Inner Size: 54.50"W X 76.00"D

Inner Size of Drawer: 20.00"W X 15.00"D X 4.00"H X 0.25"T

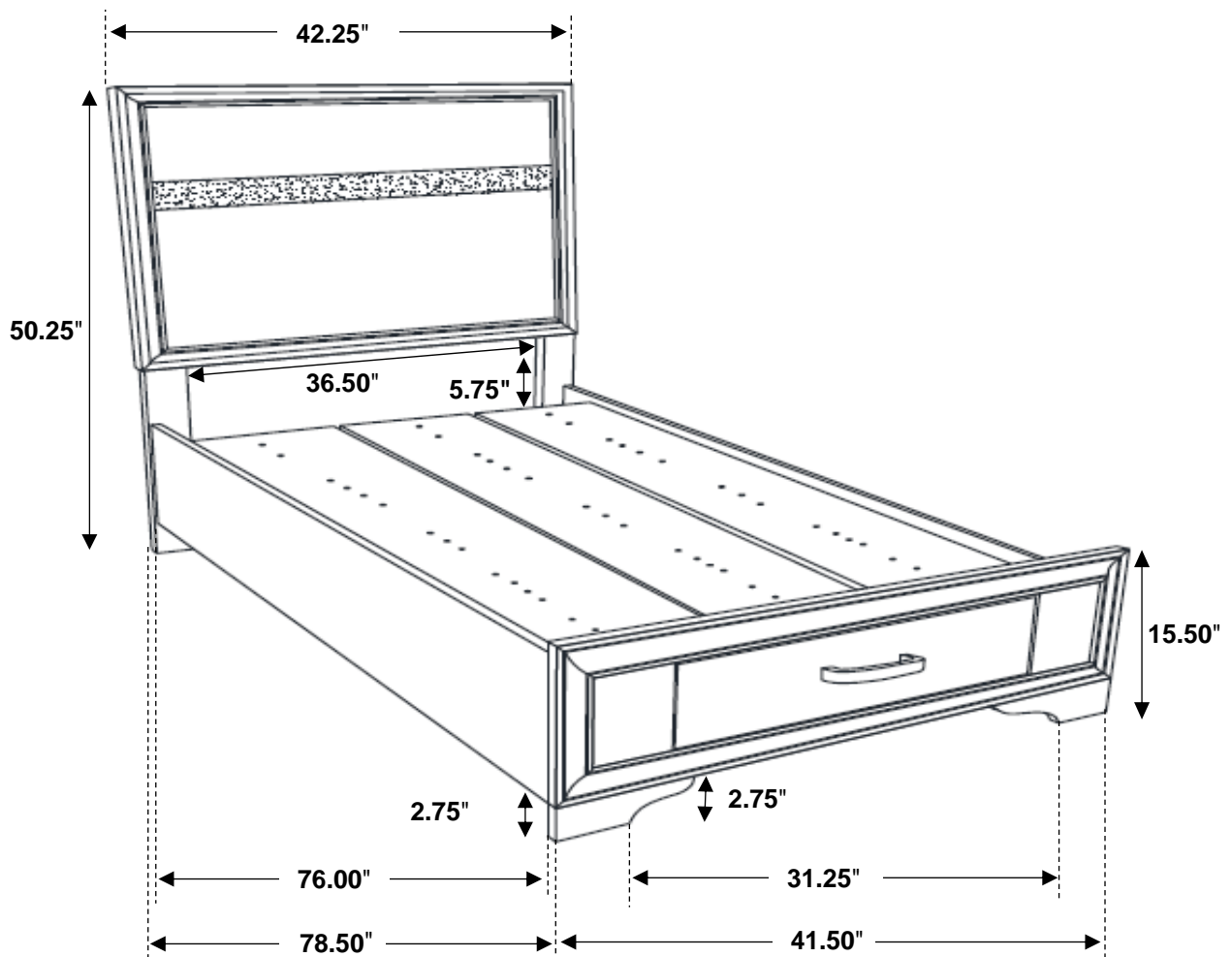

Note: Dimension tolerance  $\pm 5\%$

# *ASSEMBLY INSTRUCTIONS*



# ASSEMBLY INSTRUCTIONS

## ASSEMBLY TIPS:

1. Remove hardware from box and sort by size.
2. Please check to see that all hardware and parts are present prior to start of assembly.
3. Please follow attached instructions in the same sequence as numbered to assure fast & easy assembly.



### WARNING!

1. Don't attempt to repair or modify parts that are broken or defective. Please contact the store immediately.
2. This product is for home use only and not intended for commercial establishments.



ASSEMBLY TIME

5 MINUTES

## PARTS IDENTIFICATION

A NIGHTSTAND

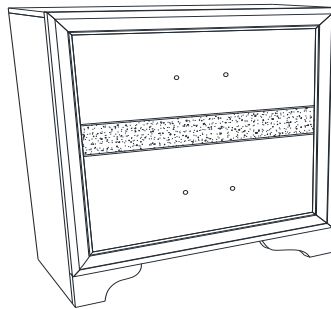

1PC

### NOTE:

Phillips head screw driver is required in the assembly process; however, manufacturer does not provide this item.

## STEP 1

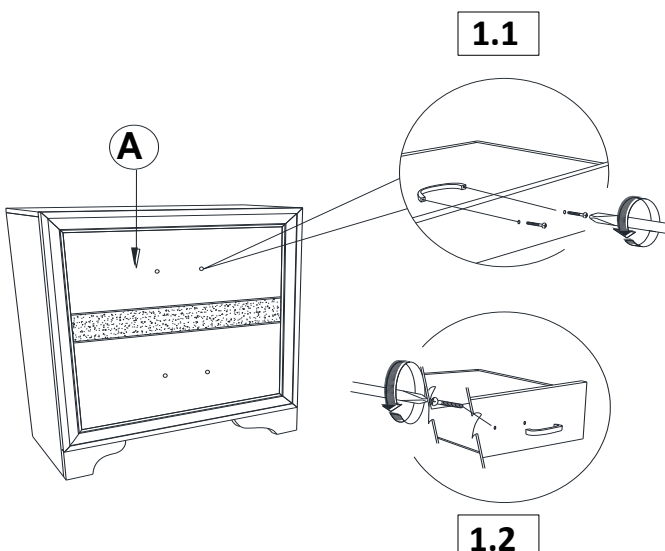

## STEP 2 COMPLETE

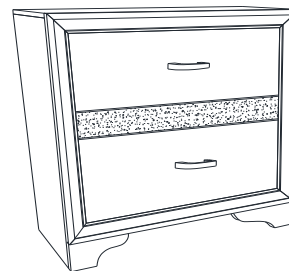



# *ASSEMBLY INSTRUCTIONS*



# ASSEMBLY INSTRUCTIONS

## ASSEMBLY TIPS:

1. Remove hardware from box and sort by size.
2. Please check to see that all hardware and parts are present prior to start of assembly.
3. Please follow attached instructions in the same sequence as numbered to assure fast & easy assembly.



### WARNING!

1. Don't attempt to repair or modify parts that are broken or defective. Please contact the store immediately.
2. This product is for home use only and not intended for commercial establishments.



ASSEMBLY TIME

5 MINUTES

## PARTS IDENTIFICATION

A DRESSER

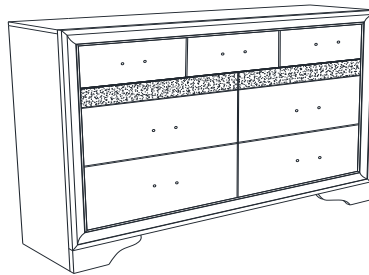

1PC

### NOTE:

Phillips head screw driver is required in the assembly process; however, manufacturer does not provide this item.

## STEP 1

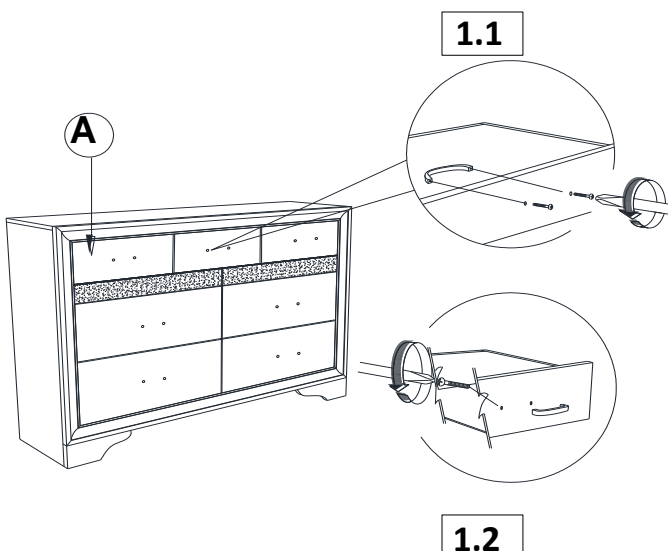

## STEP 2 COMPLETE



Inner Size of Drawer A: 17.00"W X 12.50"D X 5.00"H X 0.25"T

Inner Size of Drawer B: 26.00"W X 12.50"D X 1.25"H X 0.25"T

Inner Size of Drawer C: 26.75" W X 12.50"D X 6.00"H X 0.25"T

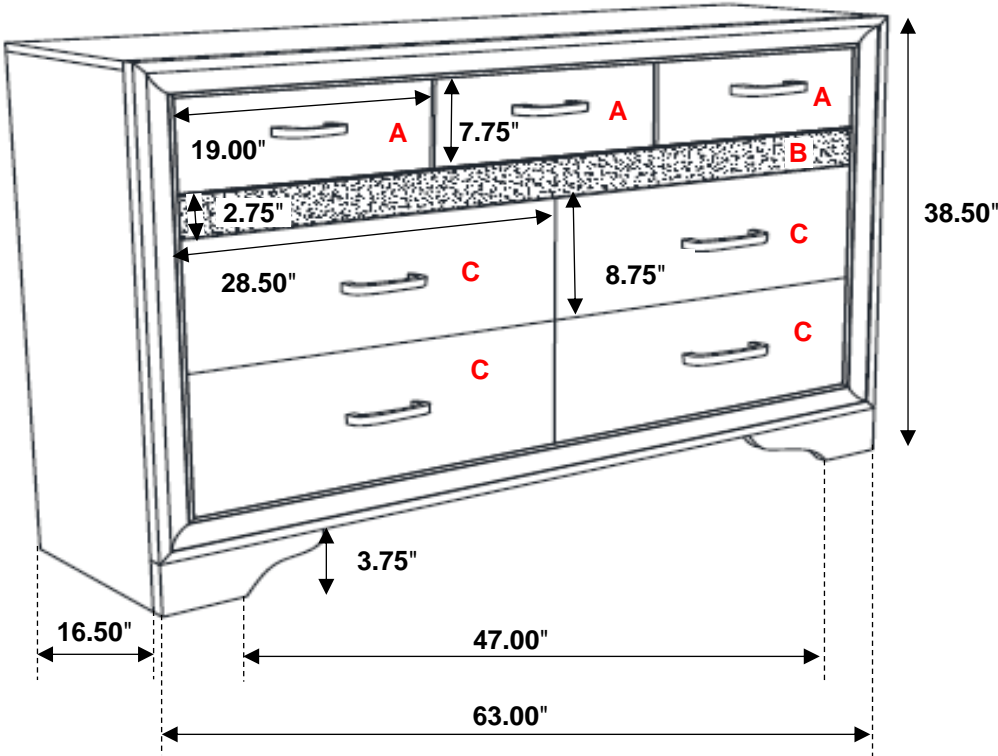

Note: Dimension tolerance  $\pm 5\%$

# *ASSEMBLY INSTRUCTIONS*



# ASSEMBLY INSTRUCTIONS

## ASSEMBLY TIPS:

1. Remove hardware from box and sort by size.
2. Please check to see that all hardware and parts are present prior to start of assembly.
3. Please follow attached instructions in the same sequence as numbered to assure fast & easy assembly.



### WARNING!



1. Don't attempt to repair or modify parts that are broken or defective. Please contact the store immediately.
2. This product is for home use only and not intended for commercial establishments.





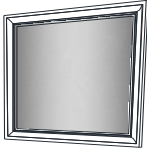
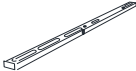

ASSEMBLY TIME

10 MINUTES

## PARTS IDENTIFICATION

|   |                                     |   |     |   |  |   |      |
|---|-------------------------------------|---|-----|---|--|---|------|
| A | MIRROR                              |    | 1PC | C | MIRROR SUPPORT<br>(PACKED WITH MIRROR) |  | 2PCS |
| B | DRESSER<br>FROM BOX ITEM<br>#205113 |  | 1PC |   |  |   |      |

## HARDWARE IDENTIFICATION

|   |                                 |   |      |   |                                       |   |      |
|---|---------------------------------|---|------|---|---------------------------------------|---|------|
| 1 | SHORT BOLT<br>(M6 x 35mm - BLK) |  | 4PCS | 4 | FLAT WASHER<br>(1/4" ID x 19mm - BLK) |  | 8PCS |
| 2 | LONG BOLT<br>(M6 x 40mm - BLK)  |  | 4PCS | 5 | ALLEN WRENCH<br>(M4 x 60MM - BLK)     |  | 1PC  |
| 3 | LOCK WASHER<br>(1/4" - BLK)     |  | 8PCS |   |                                       |   |      |

# ASSEMBLY INSTRUCTIONS

## STEP 1

ARROW MARKING FACE UPWARD

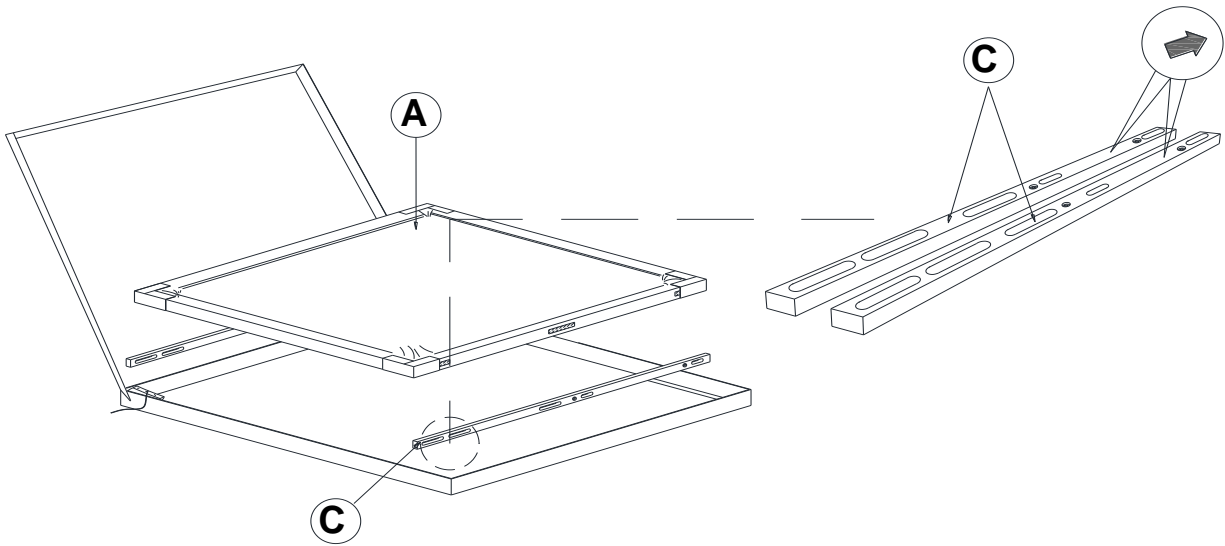

## STEP 2

ARROW MARKING FACE UPWARD

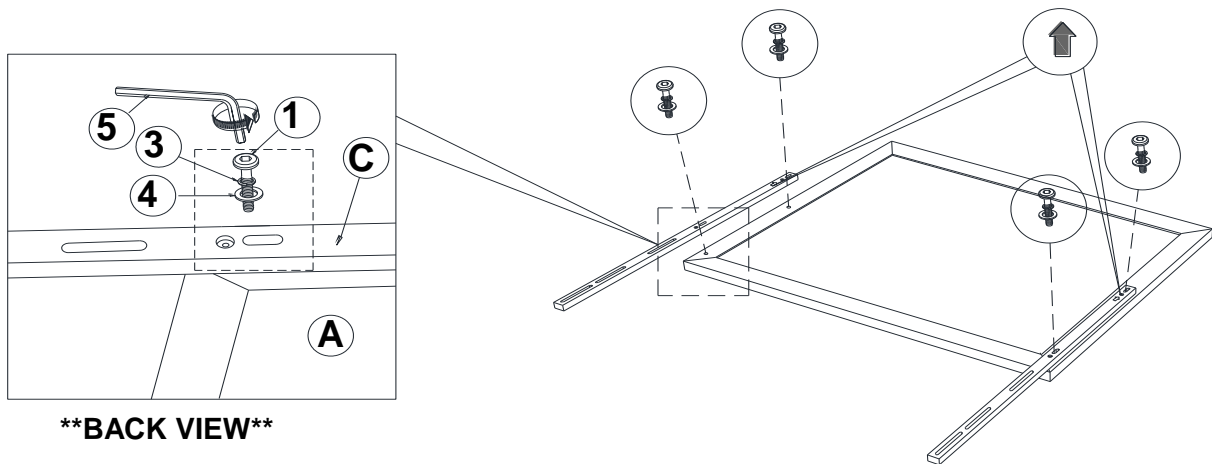

**\*\*BACK VIEW\*\***

# ASSEMBLY INSTRUCTIONS

## STEP 3

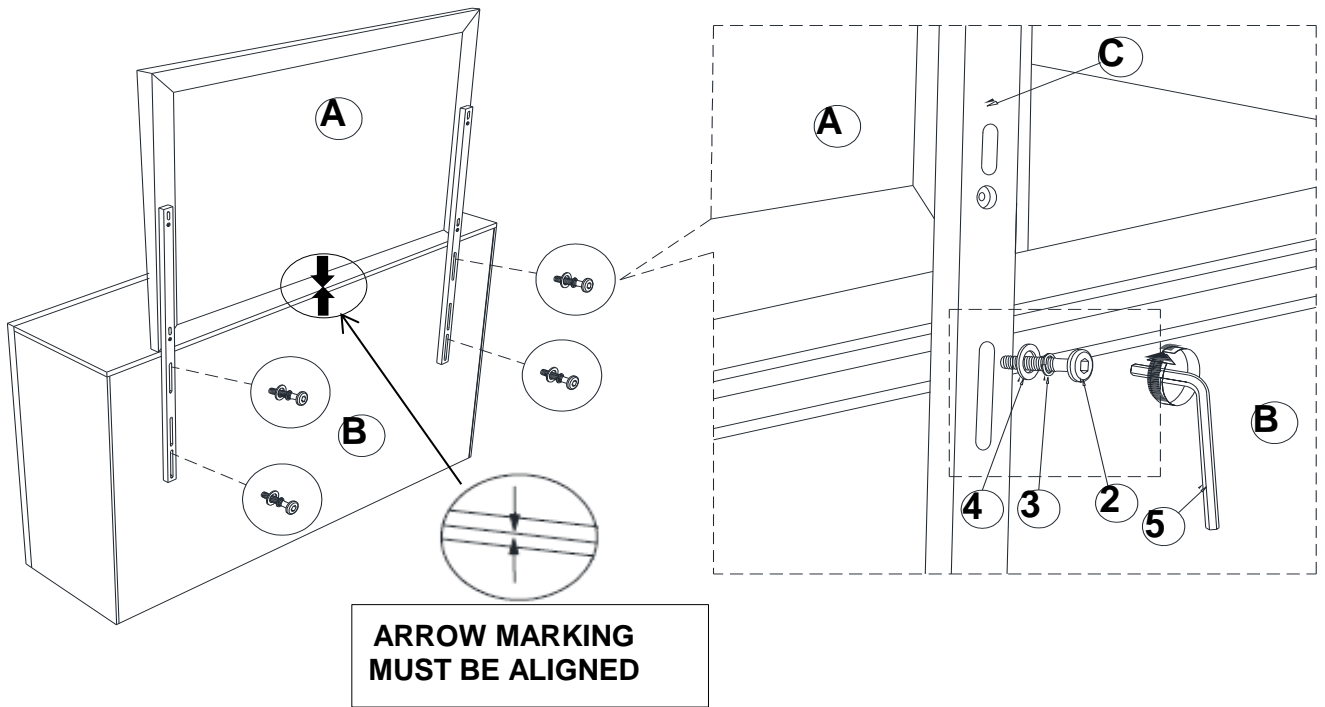

## STEP 4 COMPLETE



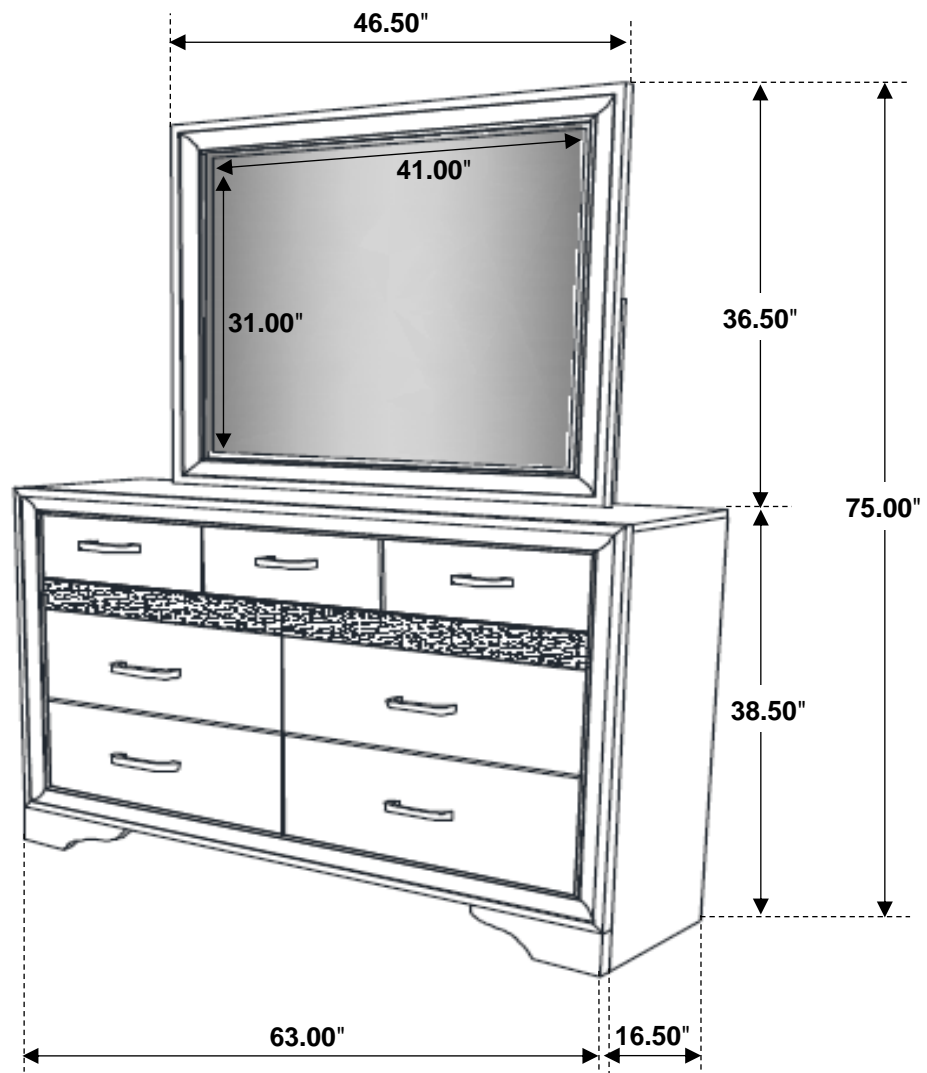

**Note: Dimension tolerance  $\pm 5\%$**