

BLAKE TALL CABINET

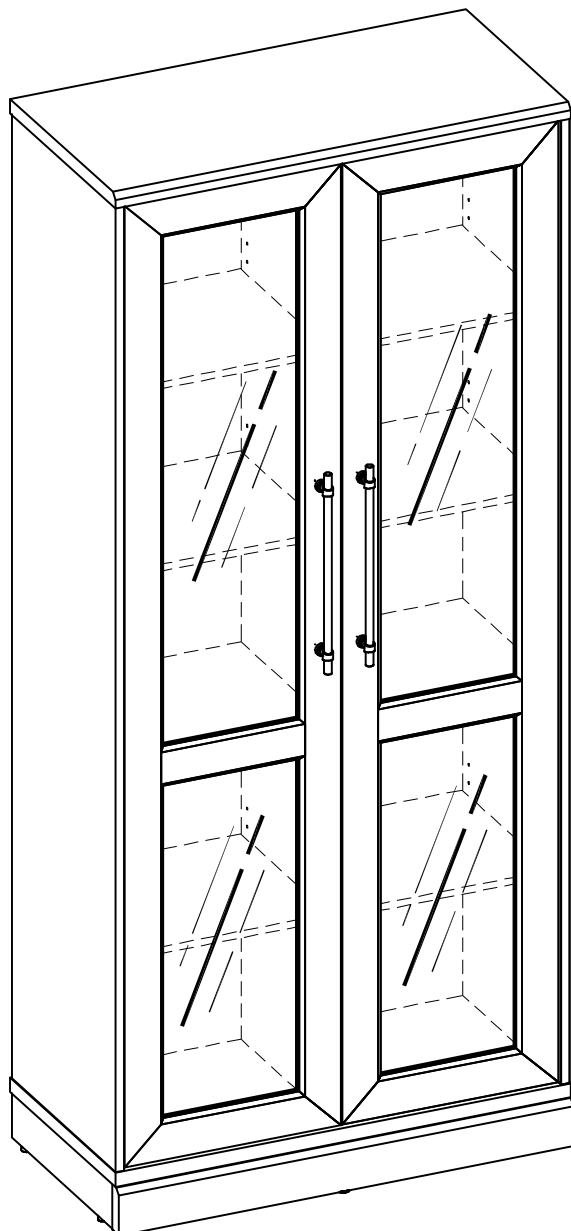

ASSEMBLY INSTRUCTIONS

mopio[®]

Join Mopio Club and enjoy your 1-Year Warranty

We've got more for you. Be part of **Mopio Club** and enjoy:

- Privileged Customer Care
- 10% Off Your Next Purchase (no min spend)
- 1-Year Free Warranty
- Early Access To Upcoming Launches

Scan the QR code or go to the link to find out more:
www.mopio.com/club



Chat With Us!

For any enquiries or issues regarding your purchase, chat with us
at www.mopio.com/chat.

Or connect with us through other channels:

✉ help@mopio.com

📘 @mopioinc

🌐 www.mopio.com

Before you start...

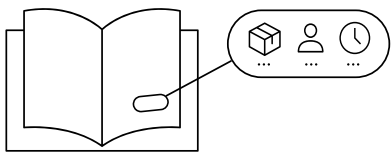

Ensure you have received all cartons and familiarize yourself with the workload. Make sure there are enough helping hands to assist you, and that you have allocated the time required to assemble your new product.

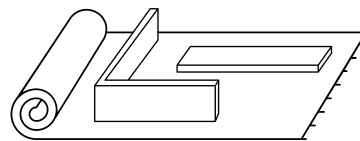

Make sure you have cleared enough space in your home for the assembly. We recommend protecting your floor with a mat or cardboard to avoid scratches during the assembly process.

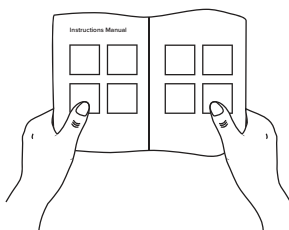

Read instructions carefully and check no parts are missing.

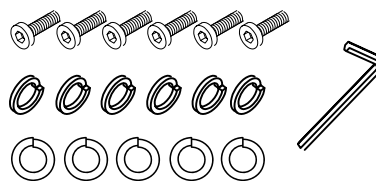

Lay out all hardware on a soft surface so you can easily identify them.

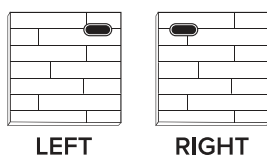

Carefully identify all components in order to differentiate which pieces are left and right.

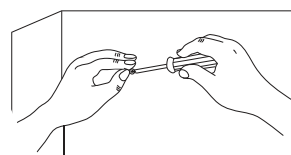

Install your new product carefully following the instructions. Don't skip ahead!

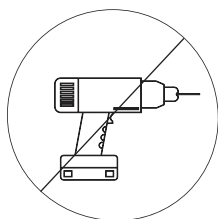

DO NOT over tighten screws or use a drill. It will damage the product.

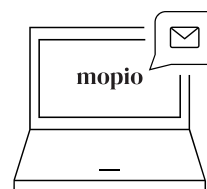

If you need further assistance with assembling your Mopio product, please chat with us at www.mopio.com#chat.

Parts

? **Missing parts? Or feeling stuck?**
 Chat with us at www.mopio.com#chat

▶ **Watch demo video at:**
www.mopio.com/pages/assembly-guide

- | | | | |
|---------------|---------------|---------------|---------------|
| □ ① x1 | □ ⑤ x1 | □ ⑨ x1 | □ ⑬ x1 |
| □ ② x1 | □ ⑥ x2 | □ ⑩ x1 | □ ⑭ x1 |
| □ ③ x1 | □ ⑦ x6 | □ ⑪ x1 | □ ⑮ x1 |
| □ ④ x1 | □ ⑧ x1 | □ ⑫ x1 | □ ⑯ x1 |

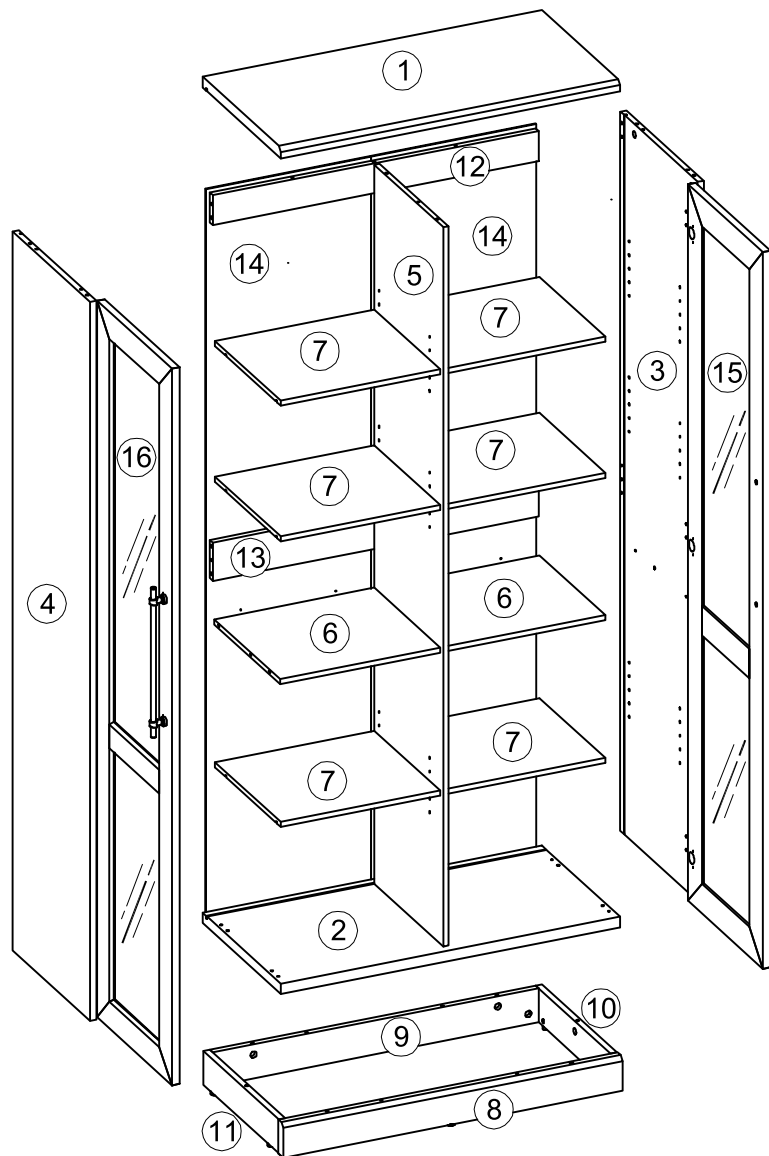

Hardware

Missing parts? Or feeling stuck?
Chat with us at www.mopio.com#chat

Watch demo video at:
www.mopio.com/pages/assembly-guide

- | | | |
|---|--|---|
| <input type="checkbox"/> Cambolt
Ø 6 x 35 mm
(A) x31 | <input type="checkbox"/> Shelf Pin
(H) x24 | <input type="checkbox"/> Rear Clam
(N) x5 |
| <input type="checkbox"/> Camlock
Ø 15 mm
(B) x31 | <input type="checkbox"/> Hinge
(I) x6 | <input type="checkbox"/> Screw
Ø 4 x 12 mm
(O) x9 |
| <input type="checkbox"/> Screw Cap
Ø 25 mm
(C) x14 | <input type="checkbox"/> Screw
Ø 7 x 14 mm
(J) x12 | <input type="checkbox"/> Wedge
(P) x16 |
| <input type="checkbox"/> Dowel
Ø 6 x 30 mm
(D) x28 | <input type="checkbox"/> Adjustable
Leveller
(K) x1 | <input type="checkbox"/> Screw
Ø 6 x 19 mm
(Q) x16 |
| <input type="checkbox"/> Screw
Ø 7 x 52 mm
(E) x6 | <input type="checkbox"/> Adjustable
Leveller
(L) x4 | <input type="checkbox"/> Wall Tipping
(R) x2 |
| <input type="checkbox"/> Handle
(F) x2 | <input type="checkbox"/> Barrel Nut
(M) x5 | <input type="checkbox"/> Screw
Ø 6 x 19 mm
(S) x2 |
| <input type="checkbox"/> Bolt
M4 x 25 mm
(G) x4 | | |

- This product will require 2hrs for assembly. We hope that you will enjoy the assembly process and hang in there!
- There are inner box(es) that include components required to complete this assembly.
- Please do not completely tighten all the hardware, until each assembly step is complete.
- Before discarding the packaging, please use the checklist to ensure that you have all the parts required to assemble your product. Please kindly note you will need the original package if you want to return the product later.
- If parts are missing or damaged, we will gladly ship your replacements parts free of charge. Please contact us at help@mopio.com or chat with us at www.mopio.com#chat.

x1

x2

120 mins

Pre-Assembly

Panels and boards are not packed in accordance to assembly step. Suggestion to unpack everything before starting.

A string is attached to hardware box for easy access.

Step 1

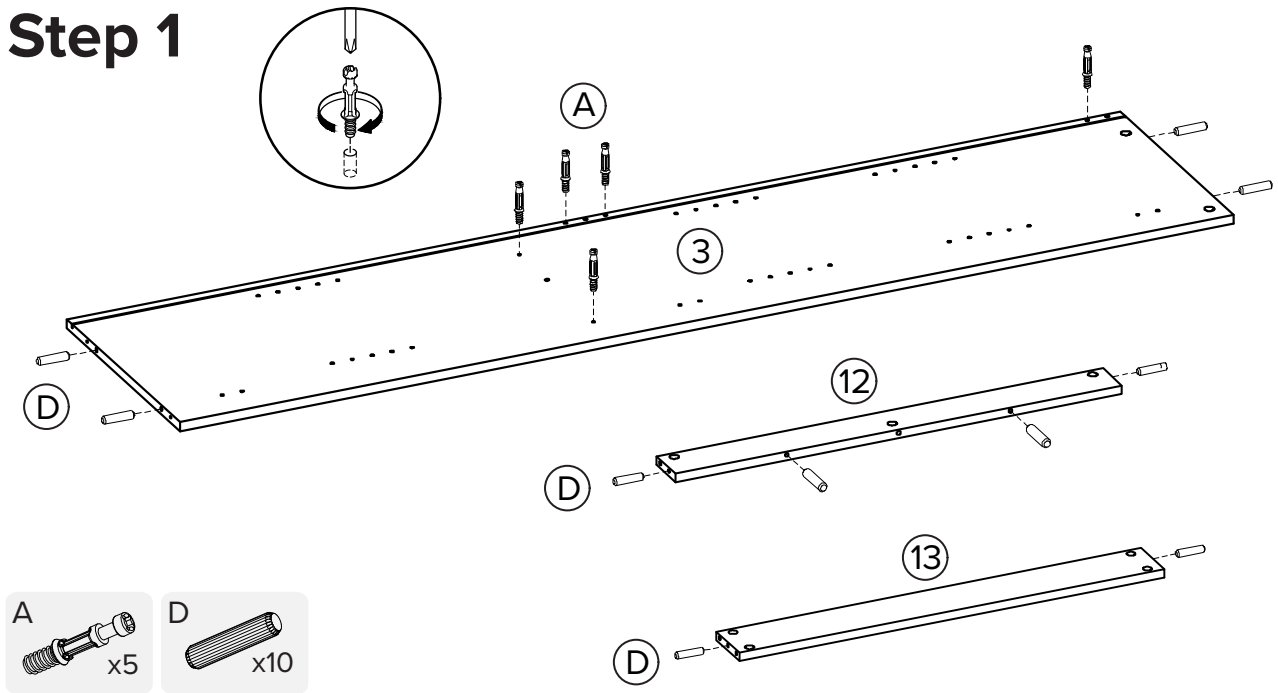

Step 2

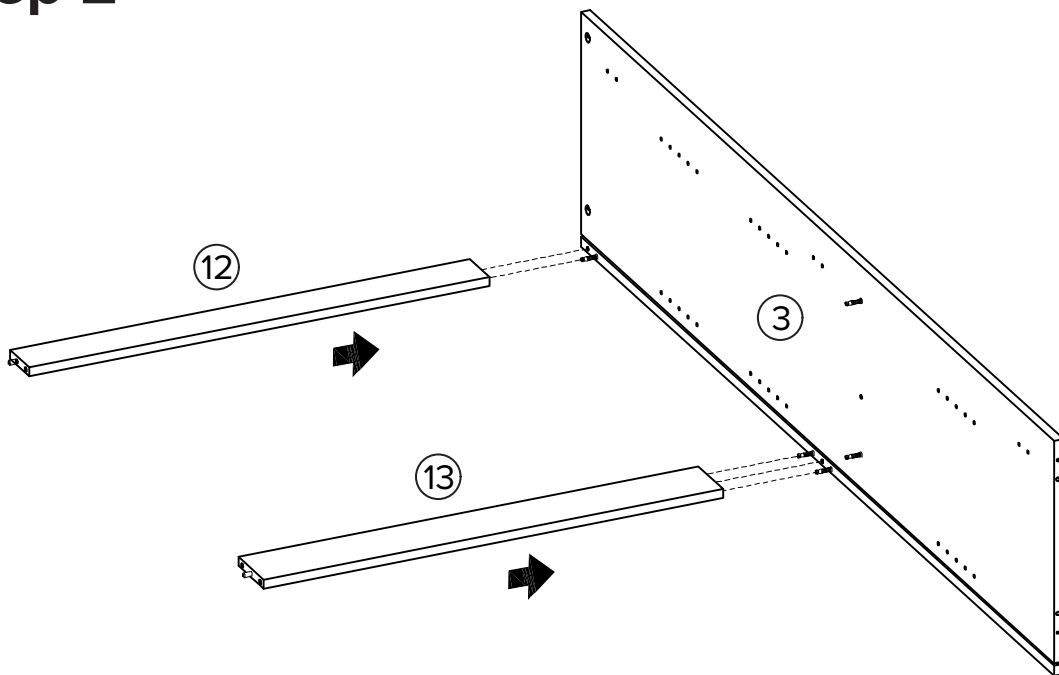

Step 3

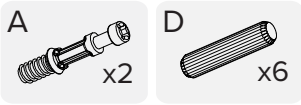
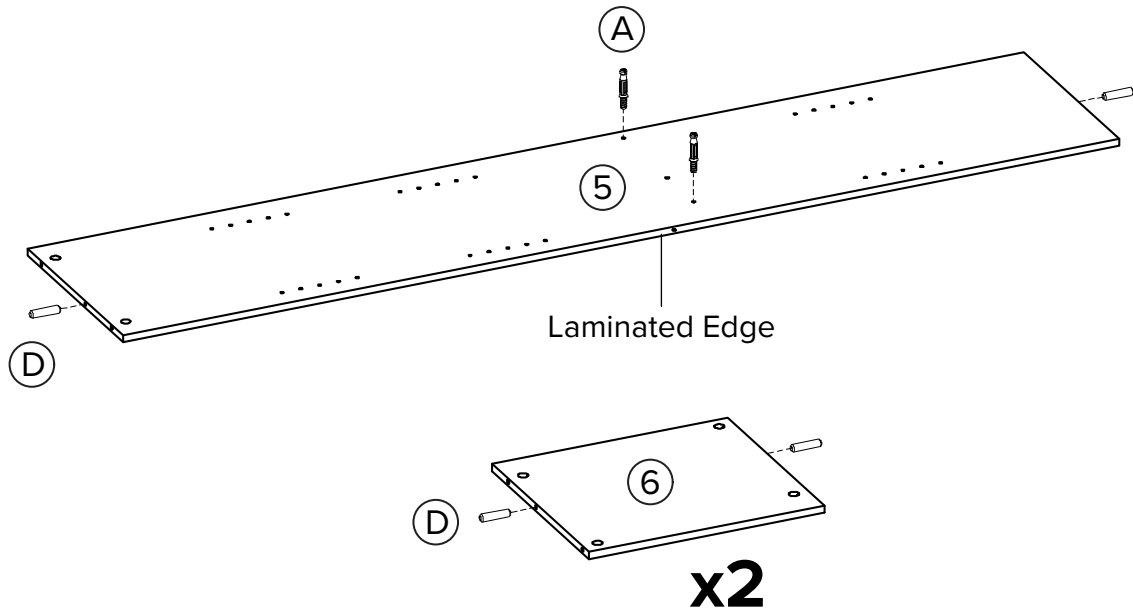

Step 4

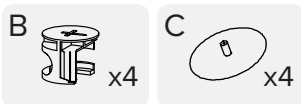
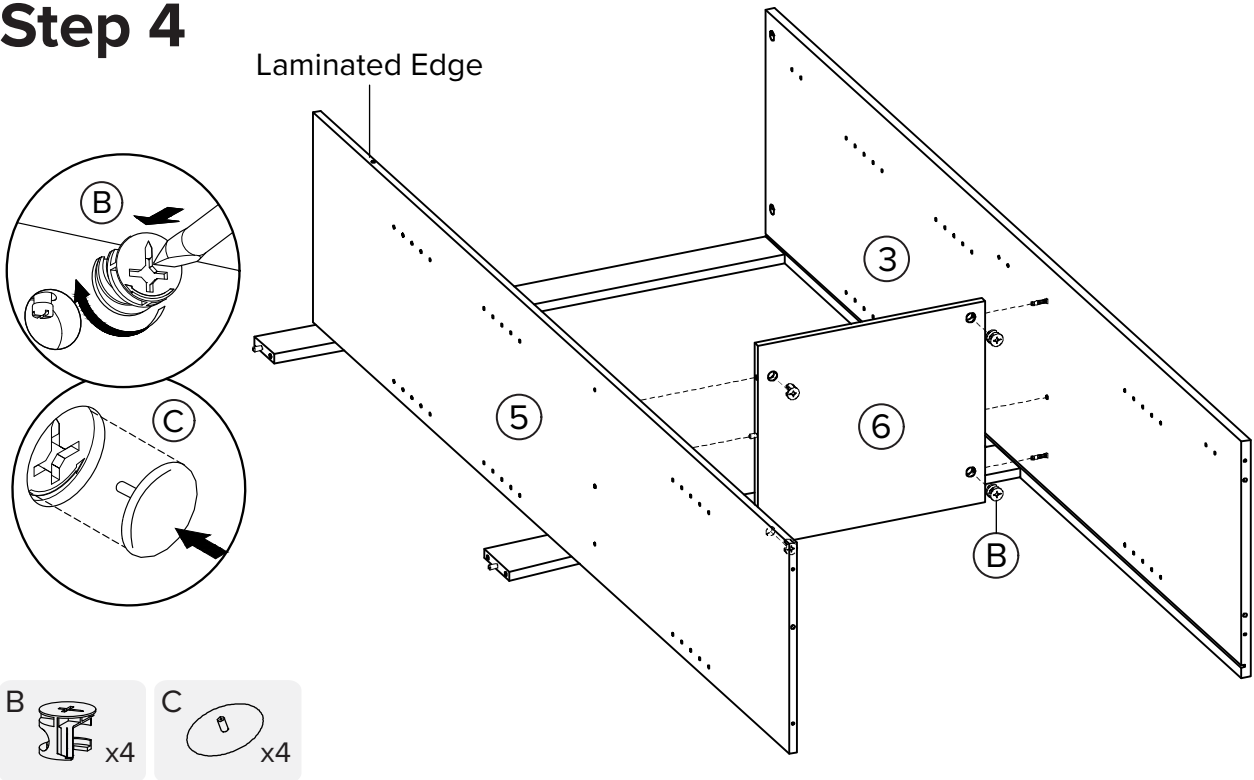

Step 5

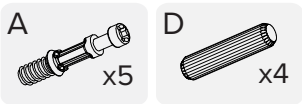
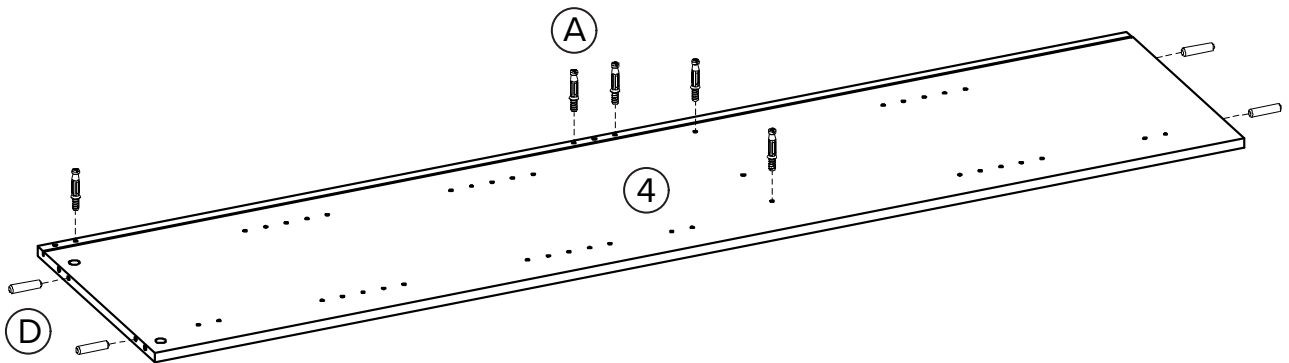

Step 6

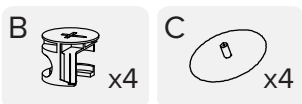
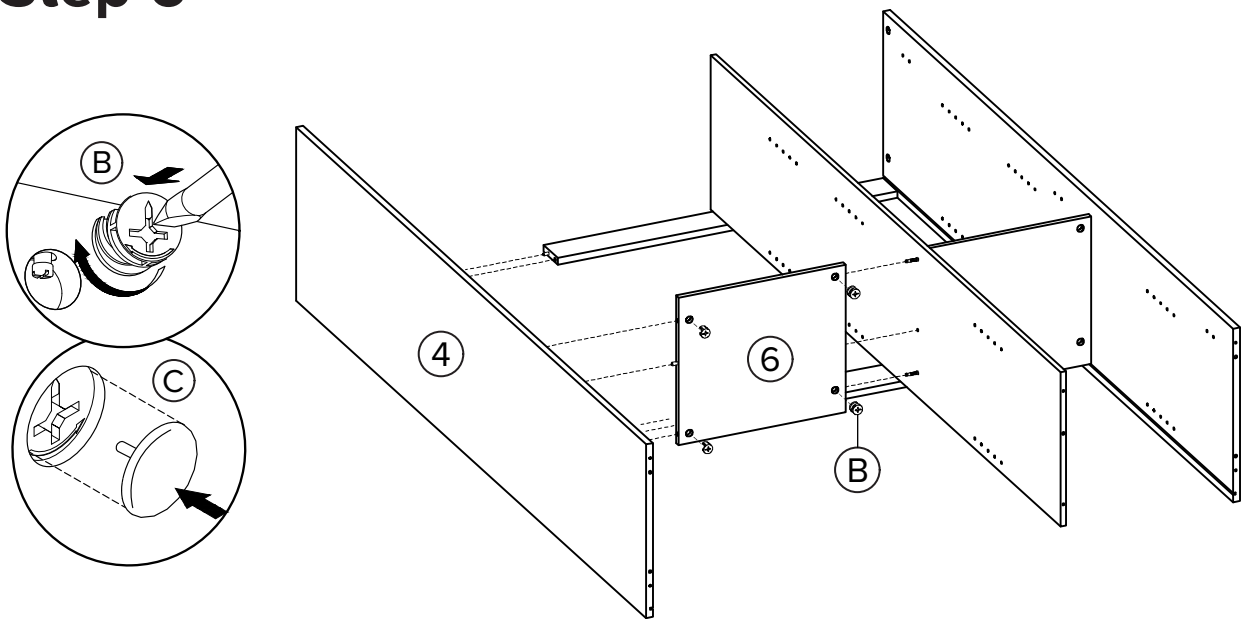

Step 7

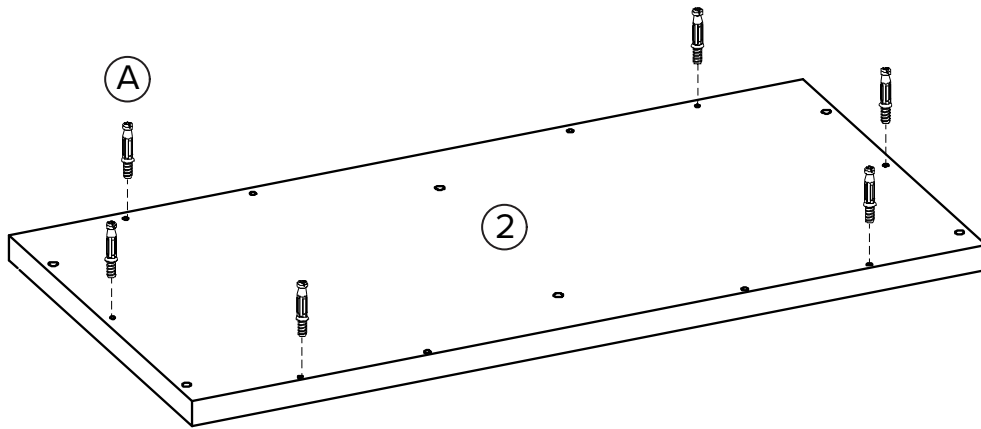

Step 8

Ensure that all the grooves are aligned before assembling.

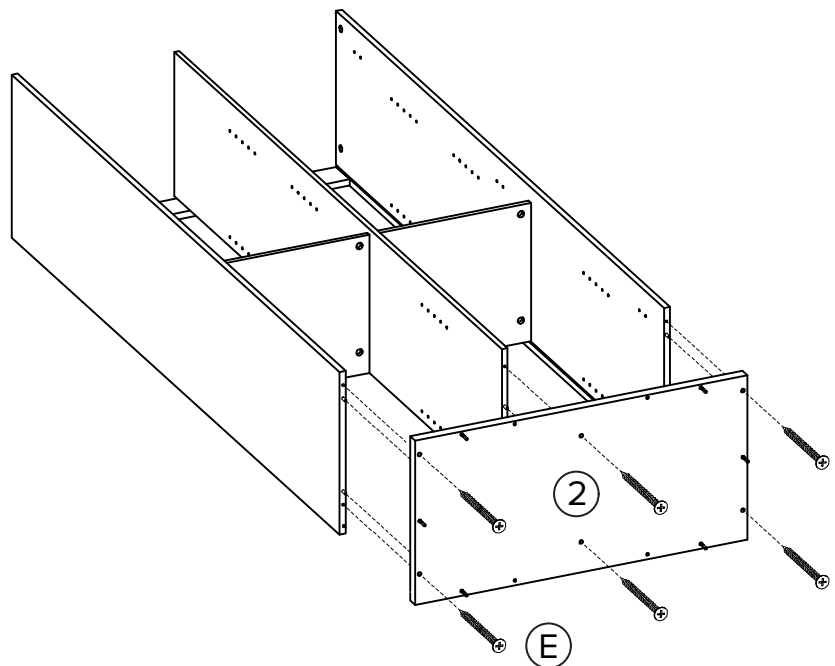

Step 9

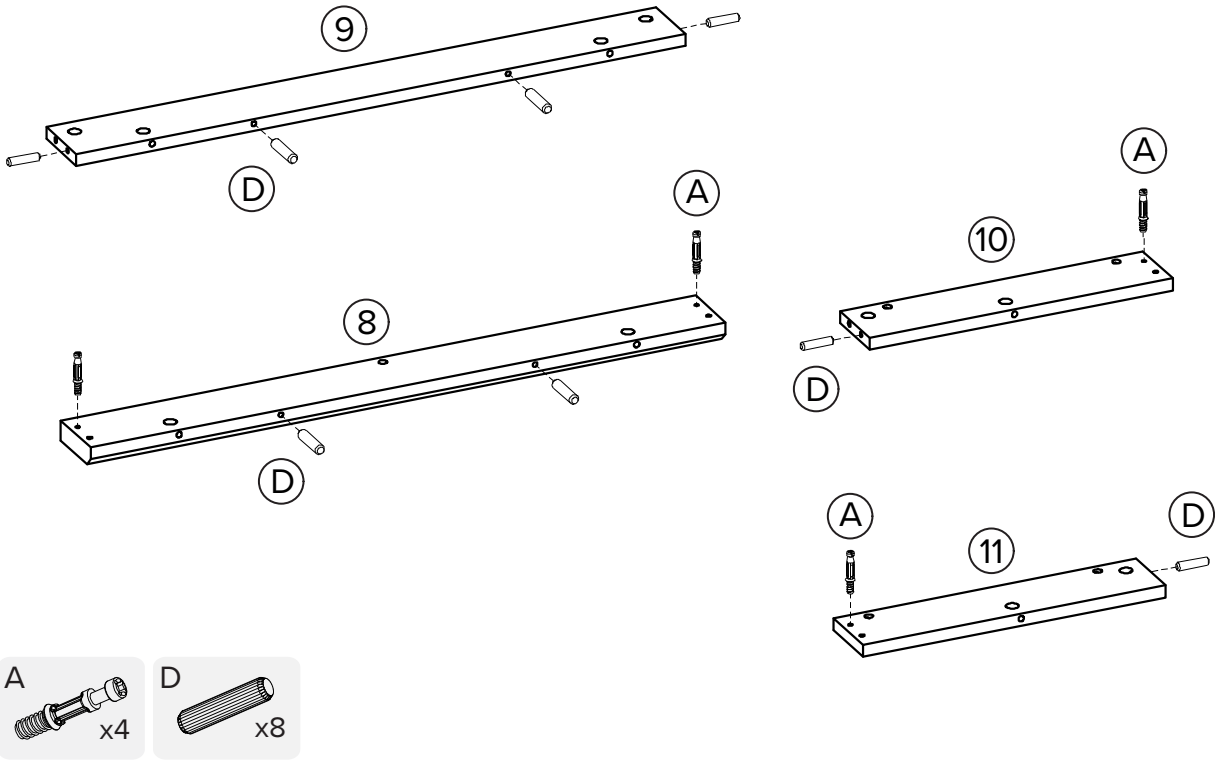

Step 10

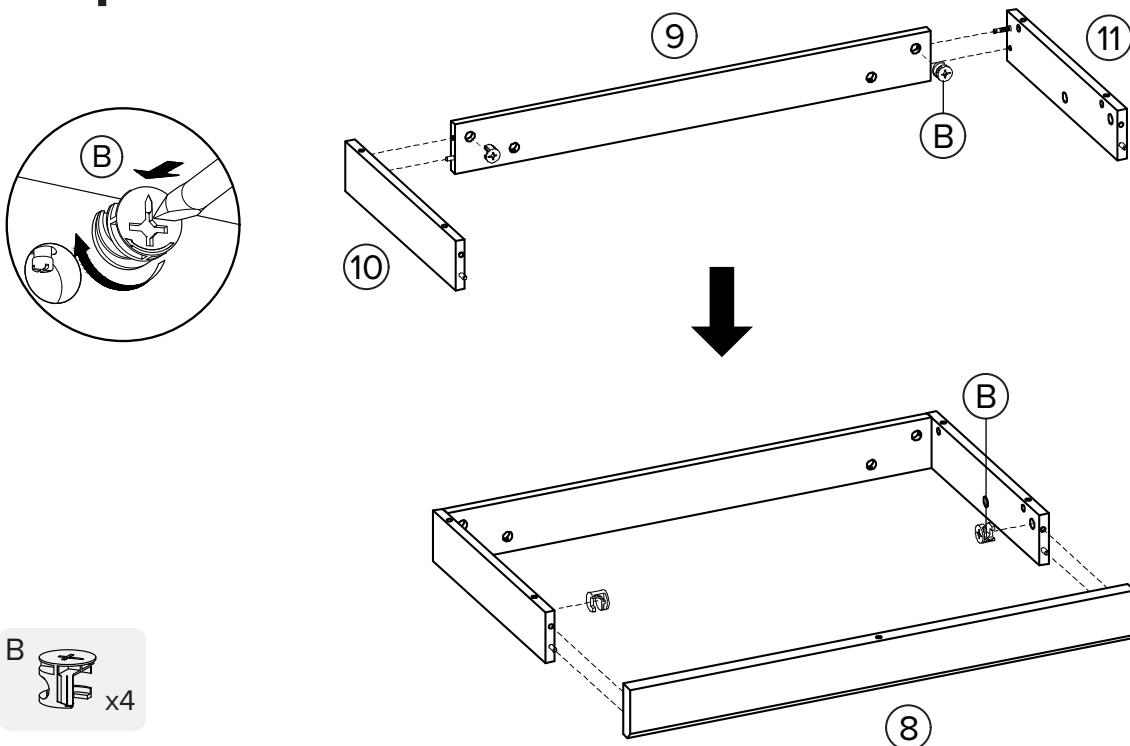

Step 11

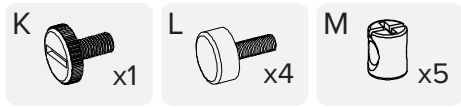
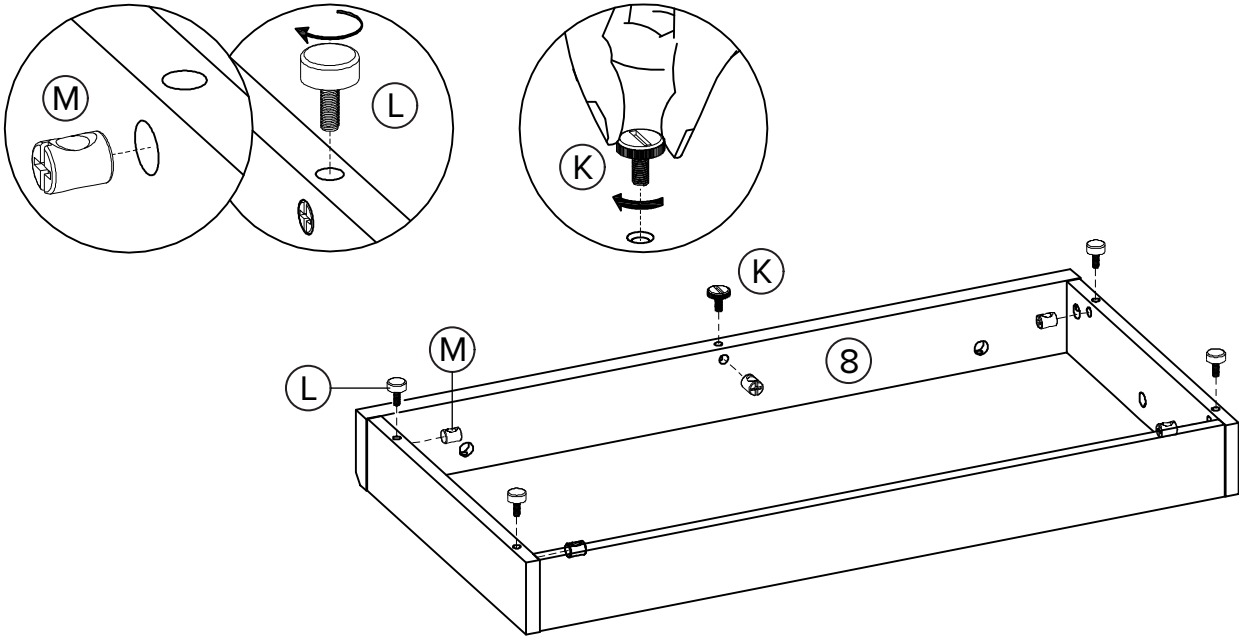

Step 12

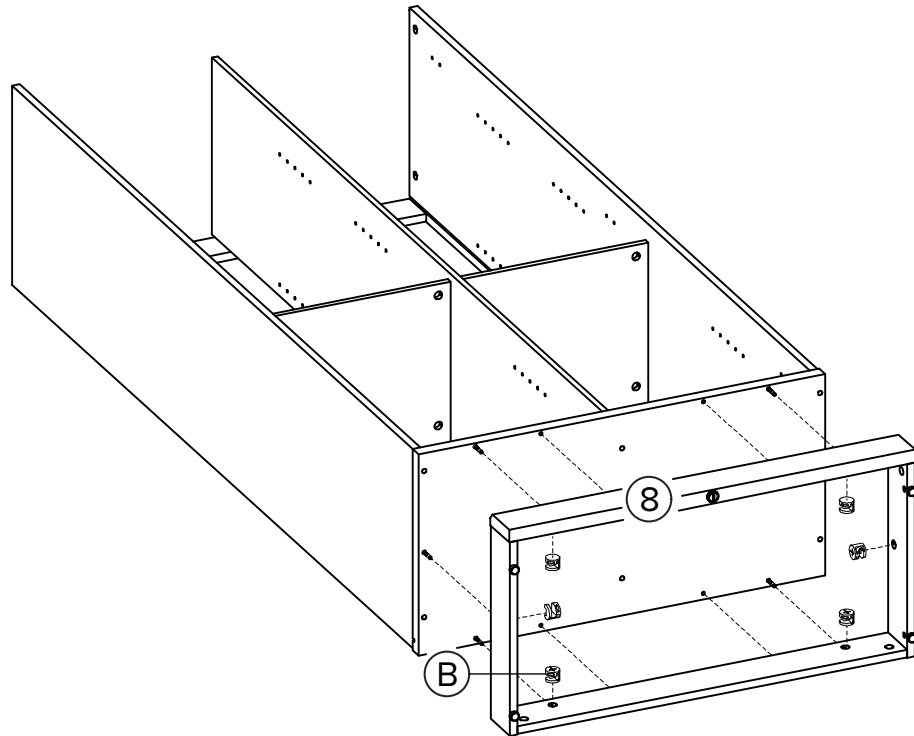
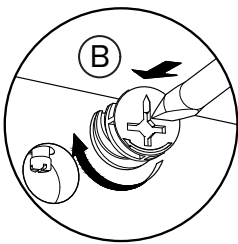

Step 13

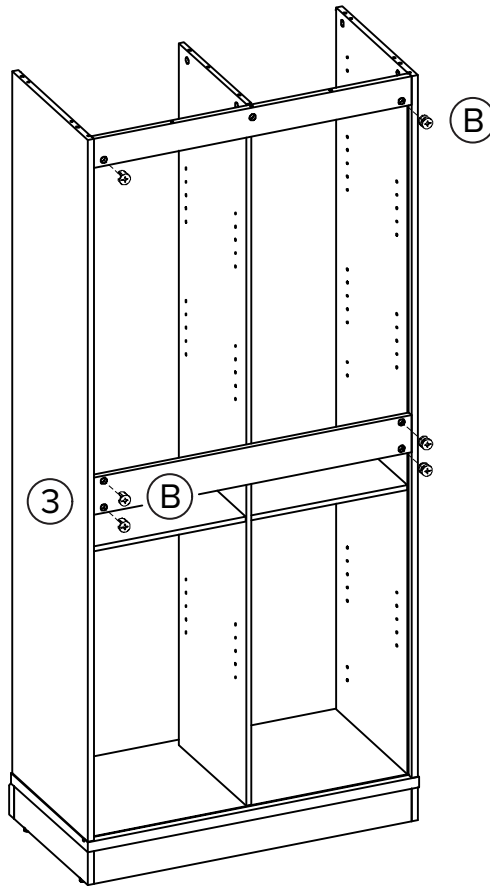
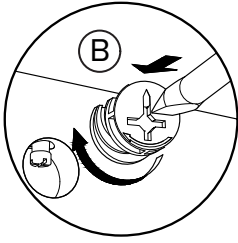

Step 14

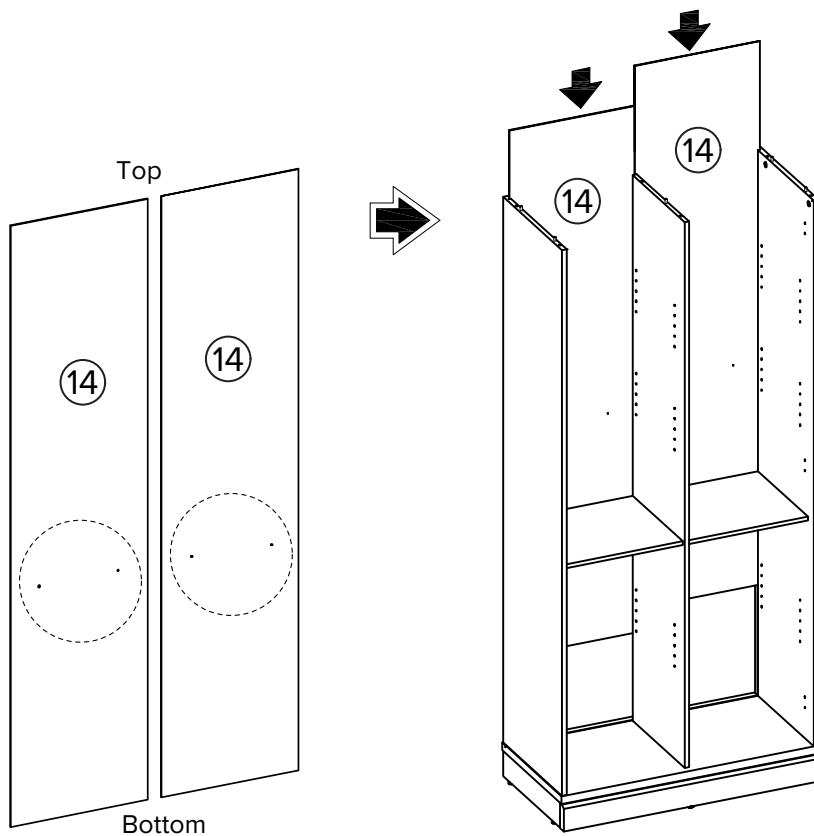

Step 15

The Camlock (B) at the back of the product does not have a Screw Cap (C).

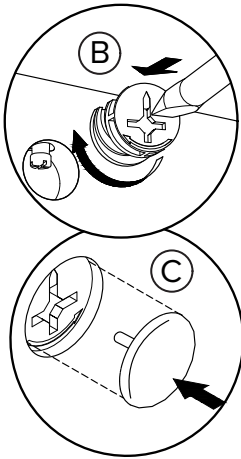
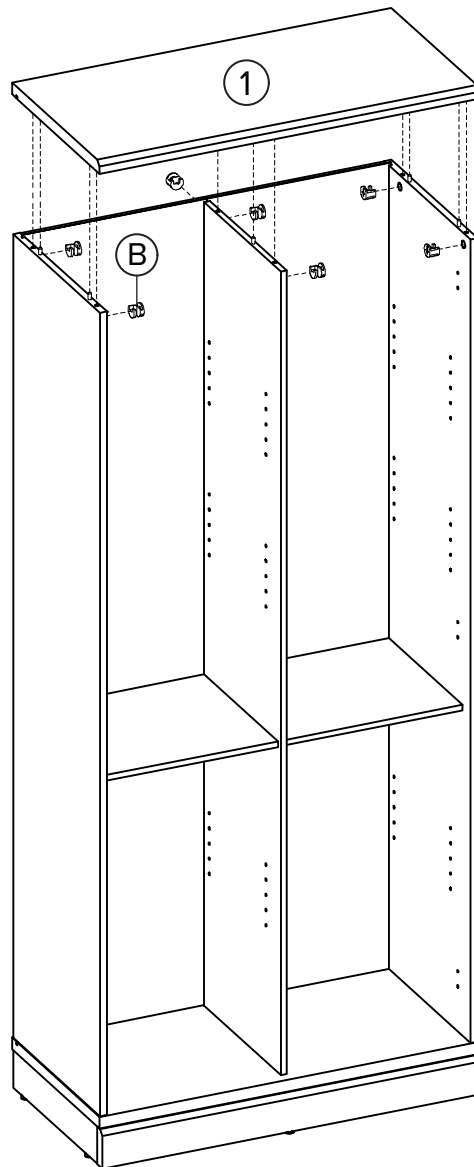
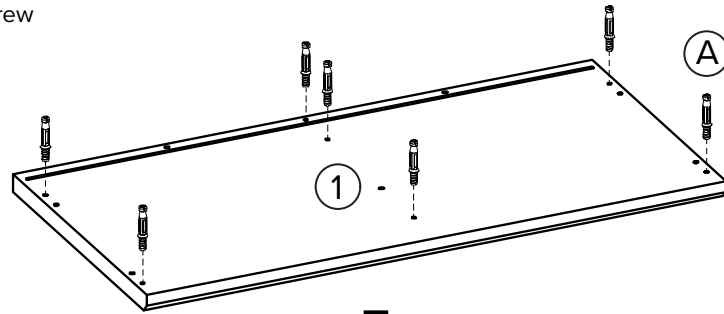



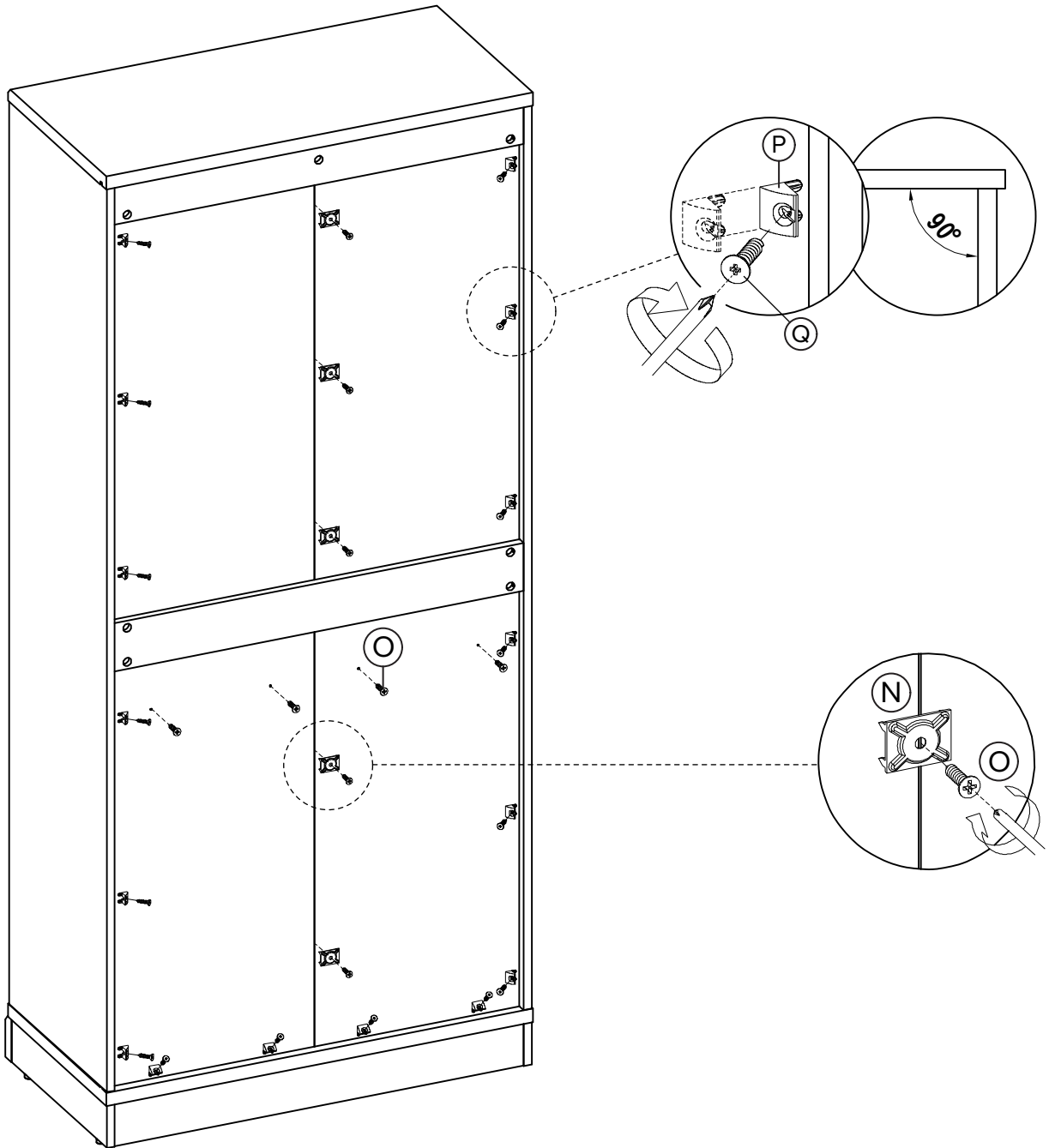

 **Missing parts? Or feeling stuck?**
Chat with us at www.mopio.com#chat

 **Watch demo video at:**
www.mopio.com/pages/assembly-guide

Step 16



- N  x5
- O  x9
- P  x16
- Q  x16

 **Missing parts? Or feeling stuck?**
Chat with us at www.mopio.com/#chat

 **Watch demo video at:**
www.mopio.com/pages/assembly-guide

Step 17

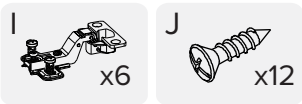
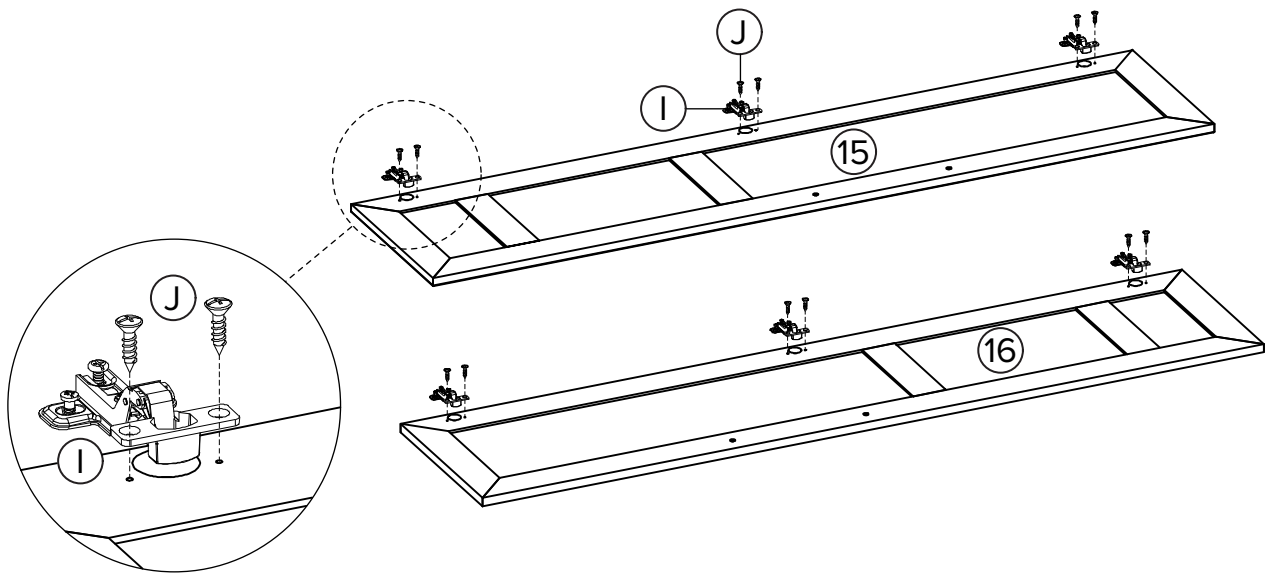

Step 18

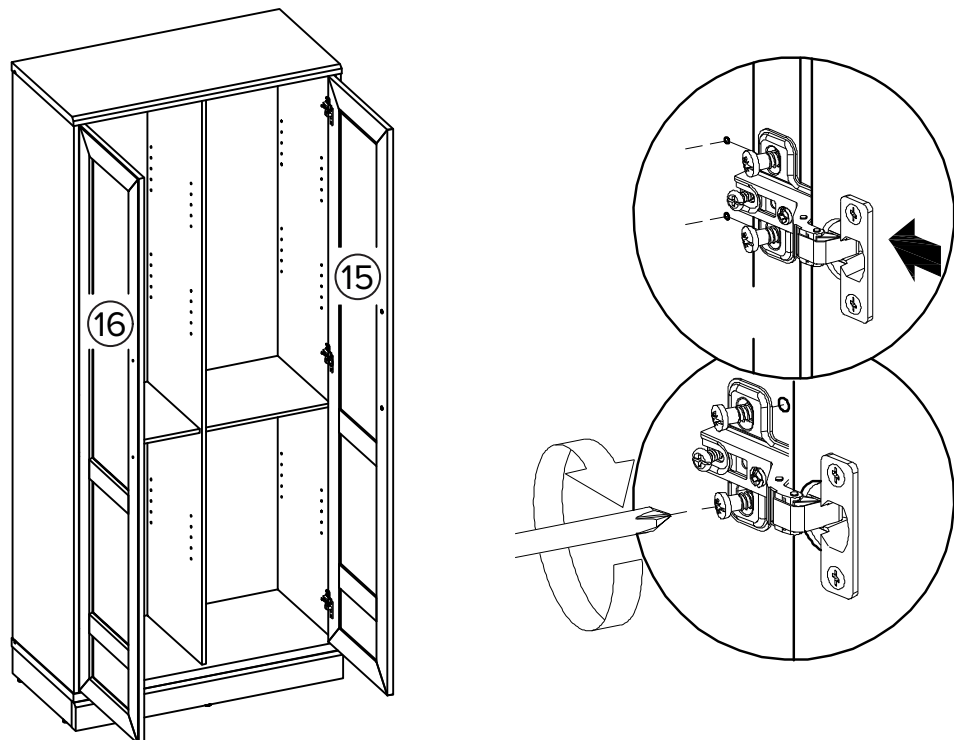

Step 19

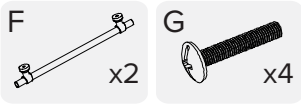
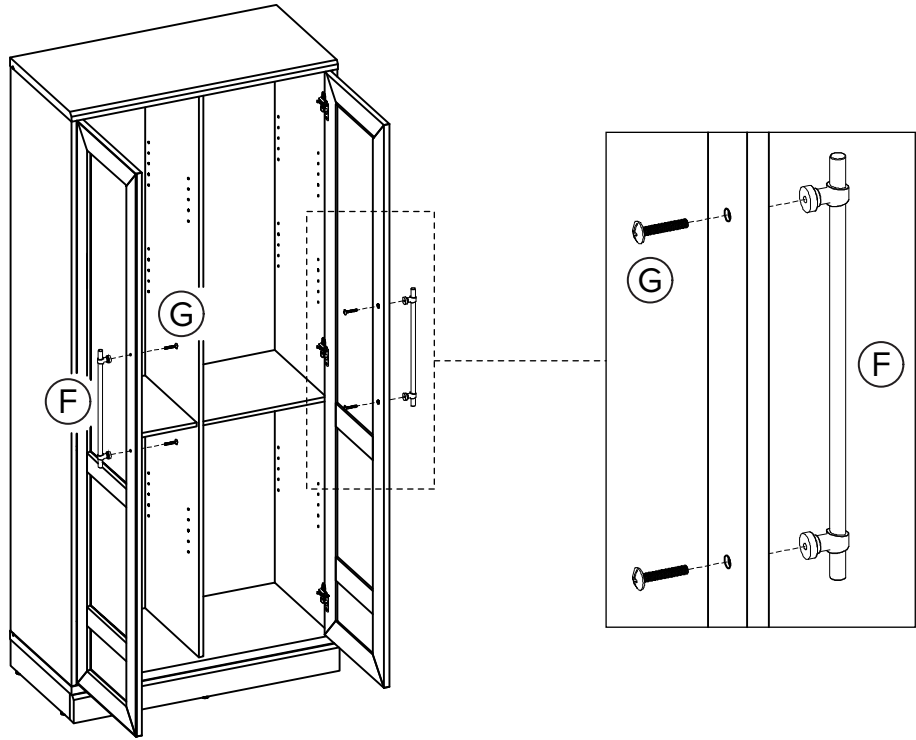

Step 20

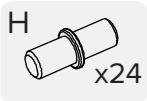
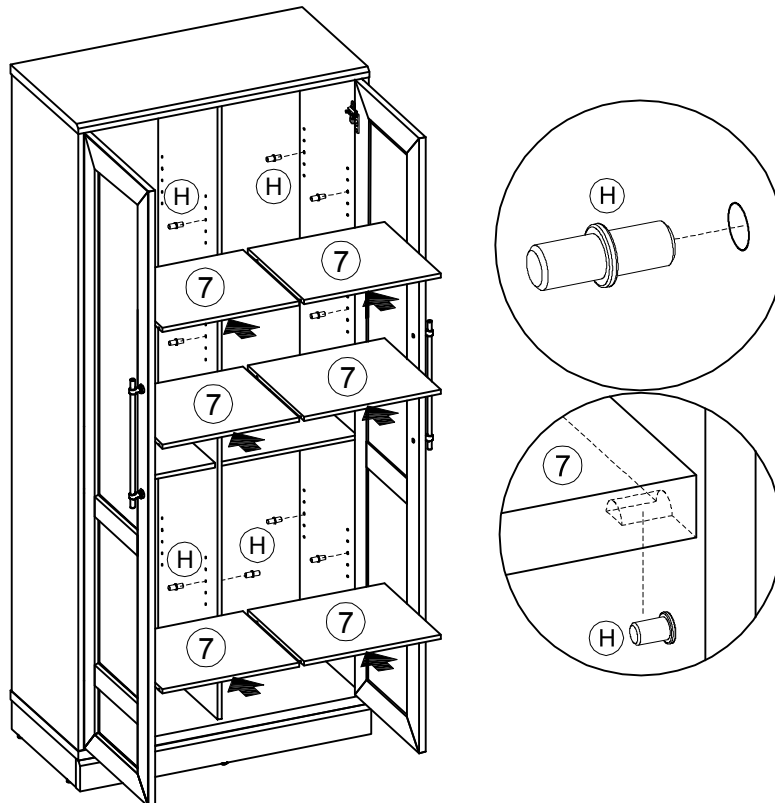

Missing parts? Or feeling stuck?
Chat with us at www.mopio.com/chat

Watch demo video at:
www.mopio.com/pages/assembly-guide

Step 21

To Adjust

To adjust the door in a front and back direction, loosen front screw a little and back screw completely. Push the door and re-tighten the back screw.

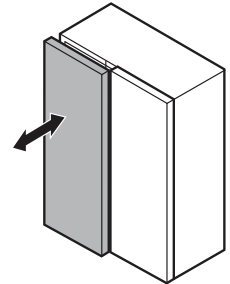
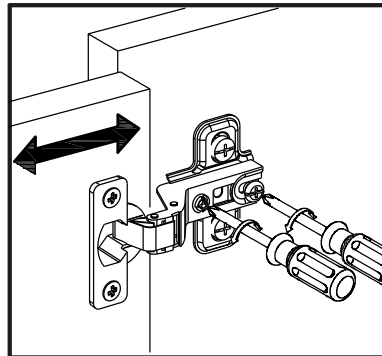

To adjust the door in a left right direction, adjust the front screw.

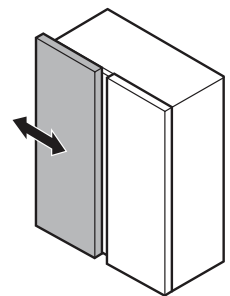
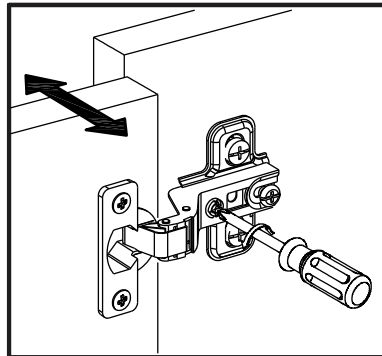

To adjust the door in an up down direction, loosen the screw on the mounting plate as shown. You may need to loosen 2 hinges in order to perform this adjustment. Push the door up or down to preferred position before retightening it

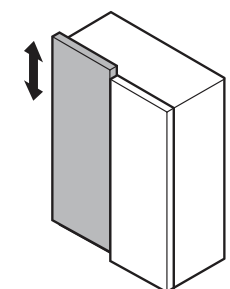
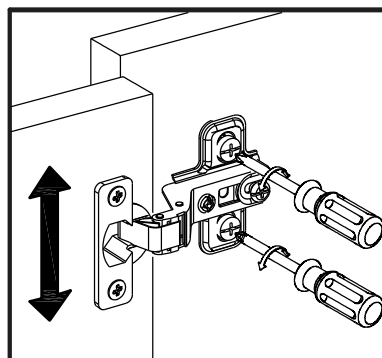

Step 22

Anti-tip Kit

To prevent injury and property damage from unexpected tipping of furniture, we highly recommend installation of the anti-tip kit included with this product.

Check periodically the screw and change the screw position if it start to lose.

Fasten Wall Tipping (R) to Top Panel with Screws (S). With help, move the product into position.

Mark fixing hole on wall and remove product. Where necessary, drill holes and mount hardware.

Reposition product and fix using hardware recommended.



Please seek professional advice if unsure of wall constructions.

Properly fixing furniture to your wall will depend on the wall material: concrete, drywall, masonry, or wood will require the appropriate hardware.

Wall anchor is not provided, please source the right wall anchor according to the wall type.

Please consult with your local hardware store to ensure you are using the correct hardware for your wall type.



This anti-tip kit is not a substitute for proper adult supervision. This anti-tip kit may provide protection against tipping furniture.

Teach and do not allow children to climb on furniture or drawers. Always keep the heavy load at the bottom of the drawer. Do not put toys or objects on the top of dresser that can attract children to climb.

By installing anti-tip kit, you acknowledge that you are fully aware of the safety requirement and accept to adhere to it. Illustrations in this guide are for reference only and may be slightly **different** from the actual object.

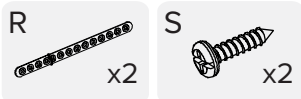
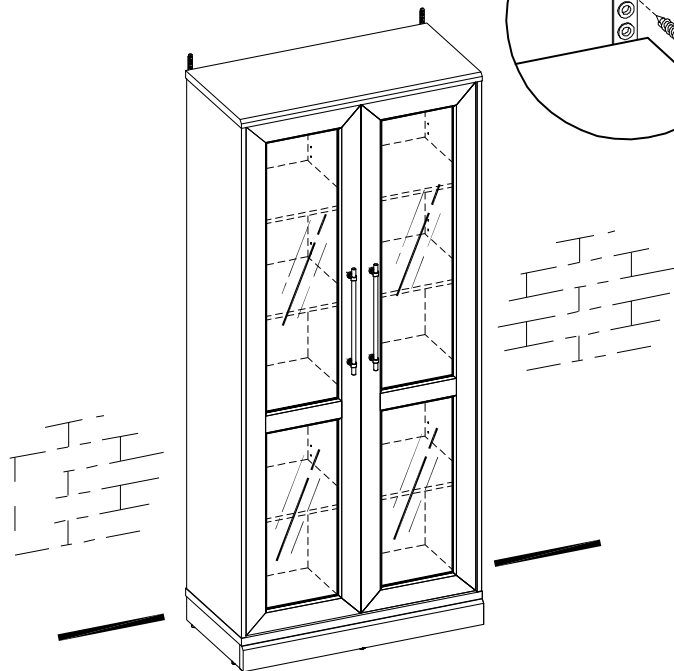
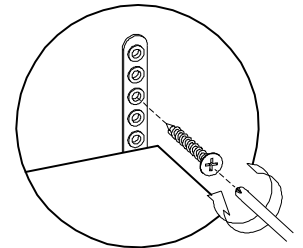
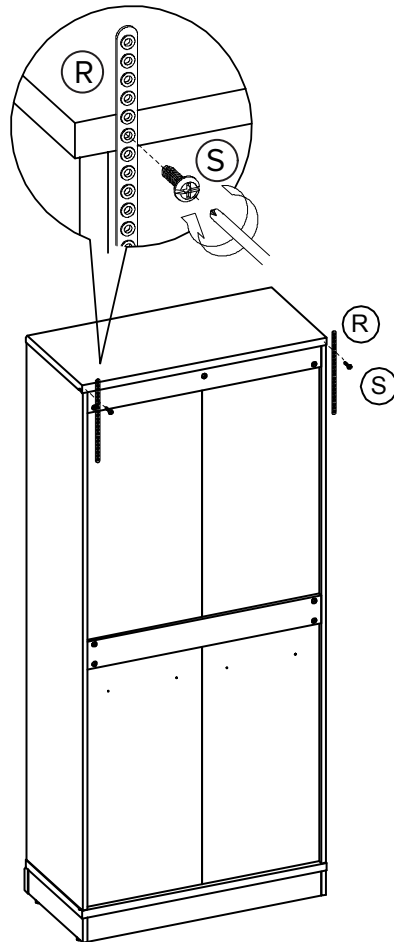

Finished!

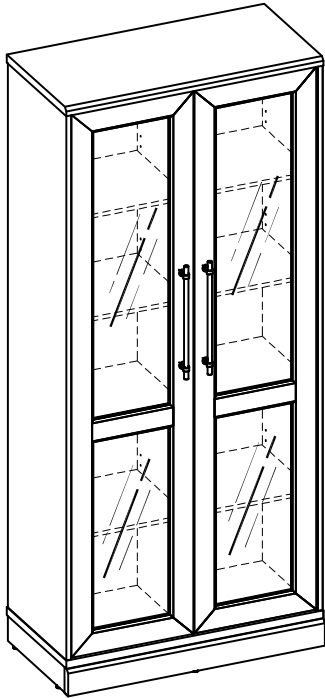

Congratulations, you have made it through the assembly process! We're almost there!☆

Please perform following checks to ensure assembly is properly done.

- To ensure the stability of the product, ensure that all wedges have been properly installed on Step 16.
- If the door's gap misaligns, please refer to Step 21.
- Ensure wall anti-tipping is installed, please refer to page 18.

Move your Mopio product carefully, with 2 people lifting it to the preferred location. Clean the product with a dry cloth. You are all set!

Enjoy your fresh and updated living space thanks to the addition of your new Mopio product!



Missing parts? Or feeling stuck?
Chat with us at www.mopio.com/#chat



Watch demo video at:
www.mopio.com/pages/assembly-guide

Care

Instructions

Your furniture, if treated with respect and love, will last you a long time. Each piece requires light maintenance to maximize its longevity.

Few quick tips before using this product:

1. Recommended weight for the top is 40 lbs and 15 lbs for each of the shelf compartment.
2. Avoid uneven weight distribution for long time as it may cause damage to the product shape.
3. Check and tighten the camlock and screw periodically as it may loose over the time.
4. Check anti tipping screw periodically, change the screw position if it start to lose.

How to take care of it?

1. Avoid direct sunlight or use curtains or blinds to limit the sun exposure to the product.
2. Clean the product regularly with a dry, soft cloth.
3. Avoid using abrasive or liquid cleanser.
4. Avoid placing hot objects onto the top surface.
5. Spillage may damage the surface. Clean immediately with a dry cloth.
6. We recommend using placemats or coasters underneath glasses, cups, bowls or plates to prevent scratches to the table surface.

Follow the care instructions and look after your furniture, in return, your furniture will look after you.

We hope to see you soon!

Frequently Asked Questions

1. What should I do if my product received is incomplete?

Mopio products are flat packed and come in separate boxes. Once your order has dispatched and been sent with Fedex, you will receive an email with tracking information. Please note that Fedex may deliver your boxes in separate deliveries. Kindly follow the tracking information, allowing all boxes to be received before starting assembly. If you need further assistance on deliveries tracking, feel free to reach out to us at www.mopio.com#chat or help@mopio.com.

2. What should I do if my shipment is damaged or products received are defective?

We're sorry to hear that! Please email us at help@mopio.com or chat with us at www.mopio.com#chat and provide a detailed description of the damage, as well as photos (or videos, where appropriate) showing the damage. We will do our best to resolve the issue as soon as possible.

3. Can replacement parts be ordered?

Yes. Simply write to our customer service team at help@mopio.com or chat with us at www.mopio.com#chat, let us know your order ID and we will be happy to assist further.

4. Who do I contact for repair queries?

You may write to us at help@mopio.com specifying your queries and we will be able to assist you further.

5. What warranty do you offer for your products?

You'll just need to submit your warranty registration upon receiving product at www.mopio.com/warranty/register and it comes with one year warranty period. You can print a copy of your order from Order Details in Amazon and upload it as your proof of purchase. More details can be found in **Warranty section**.

6. How do I claim my warranty?

Easy! Just email us at help@mopio.com and provide a detailed description of the fault as well as photos.

7. What should I do if I want to return the product?

We offer 30-day return policy upon product received. To initiate a return request, please message us through Amazon or contact our customer service team at help@mopio.com or www.mopio.com#chat with your reason of returning so we can facilitate the request and assist you further. For more details on the return policy, please refer to **Return section**.

1-Year Limited Warranty Information

Please read this limited warranty carefully. To ensure your warranty remains valid, you must comply with the following conditions. This warranty covers only manufacturing defects and does not include damages caused by misuse of the product. Full details are available at <https://mopio.com/pages/product-warranty>.

Activate within 30 Days

Activate your warranty within 30 days of receiving the product at <https://mopio.com/pages/mopioclub>.

Warranty against manufacturing defects, starts from the date of receipt. A valid proof of purchase is required for warranty claims. The manufacturer's warranty and financial responsibility are applicable only to the products.

Proper Use Definition

Proper use means that the product was not abused by the User, according to the manufacturer's definition.

Inspection and Costs

The manufacturer requires inspection of the product to determine the warranty claim. Transportation or removal costs are the responsibility of the consumer.

Usage Conditions

The product should be used on a level surface where all legs touch the floor evenly, allowing even weight distribution. This warranty only covers replacement of legs and not any other parts.

Resolution of Claims

If a manufacturing defect occurs, the manufacturer will repair or replace the product at its discretion. The manufacturer reserves the right to substitute materials or models and cannot guarantee that replacement parts will match existing ones.