

Product Assembly Instructions

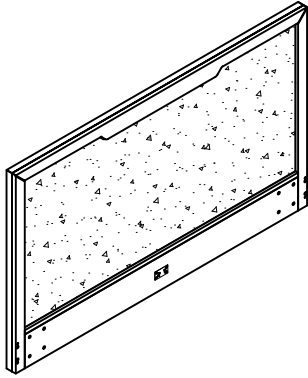

A: Head x 1

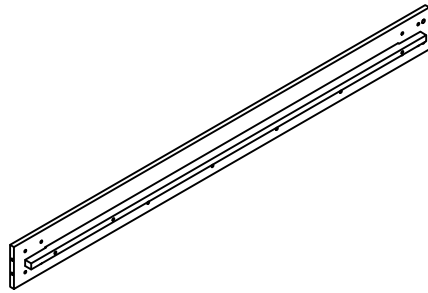

B: Side x 2



I: Bolt / M8*20mm x 48



K: Washer / Dia 19mm x 52



L: Washer / Dia 12mm x 52



M: Allen wrench x 1

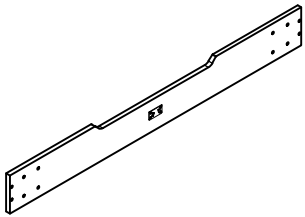

C: End x 1

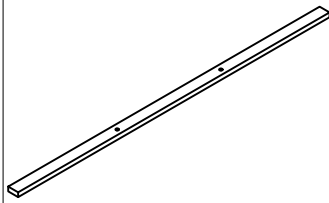

D: Support x 1

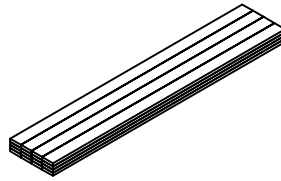

E: Slat x 16

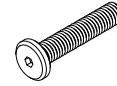

N: Bolt M8*40mm x 2

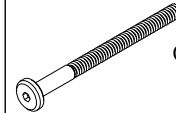

O: Bolt M6*90mm x 4



P: Insert nut x 4



F: Bracket x 4

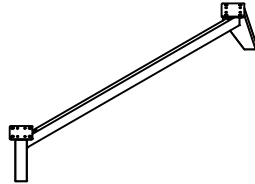

G: Leg x 2

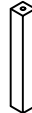

H: Support Leg x 2



Q: Screw / M4*30mm x 8



R: Dowel / Dia10*30mm x 8

STEP 1

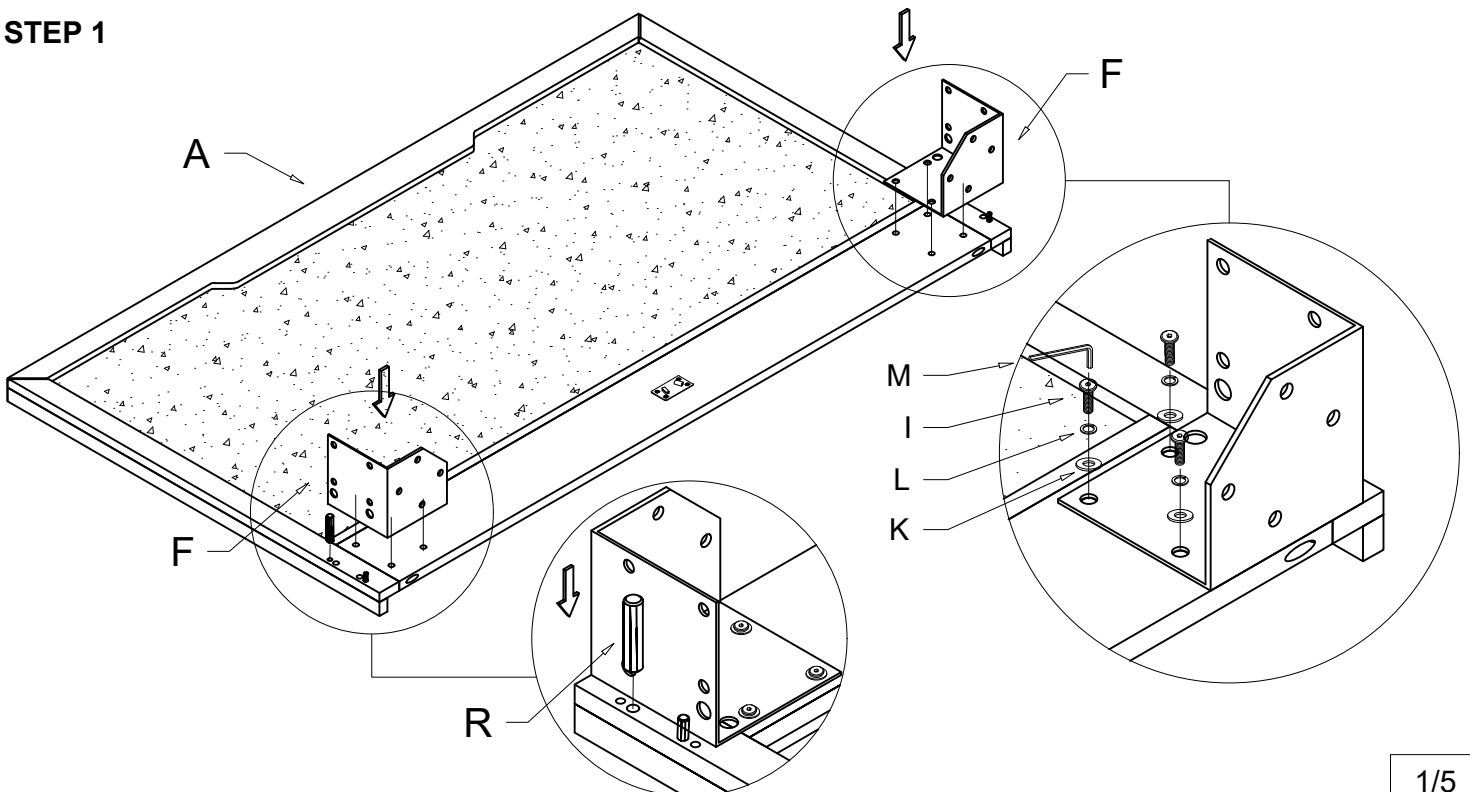

STEP 2

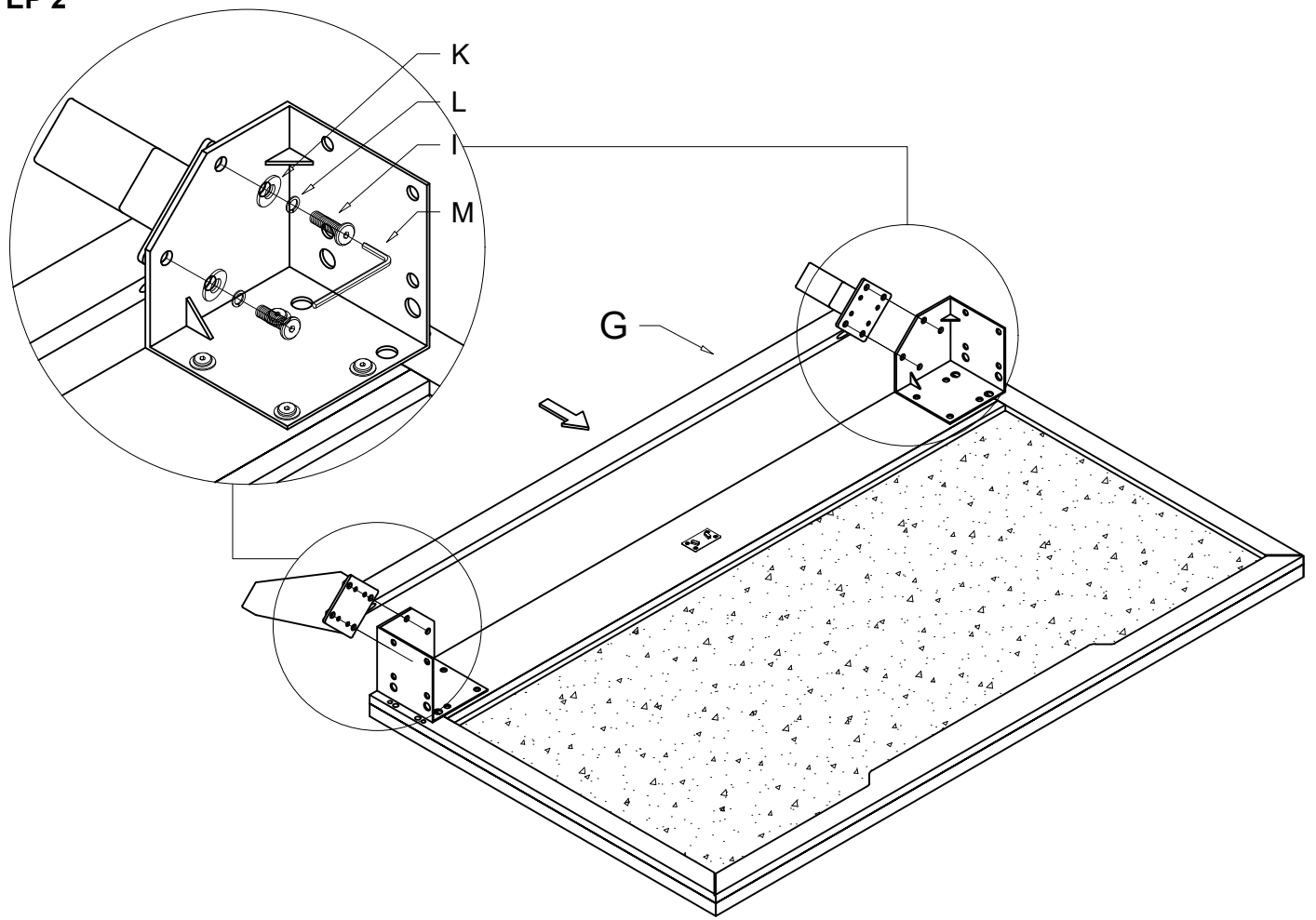

STEP 3

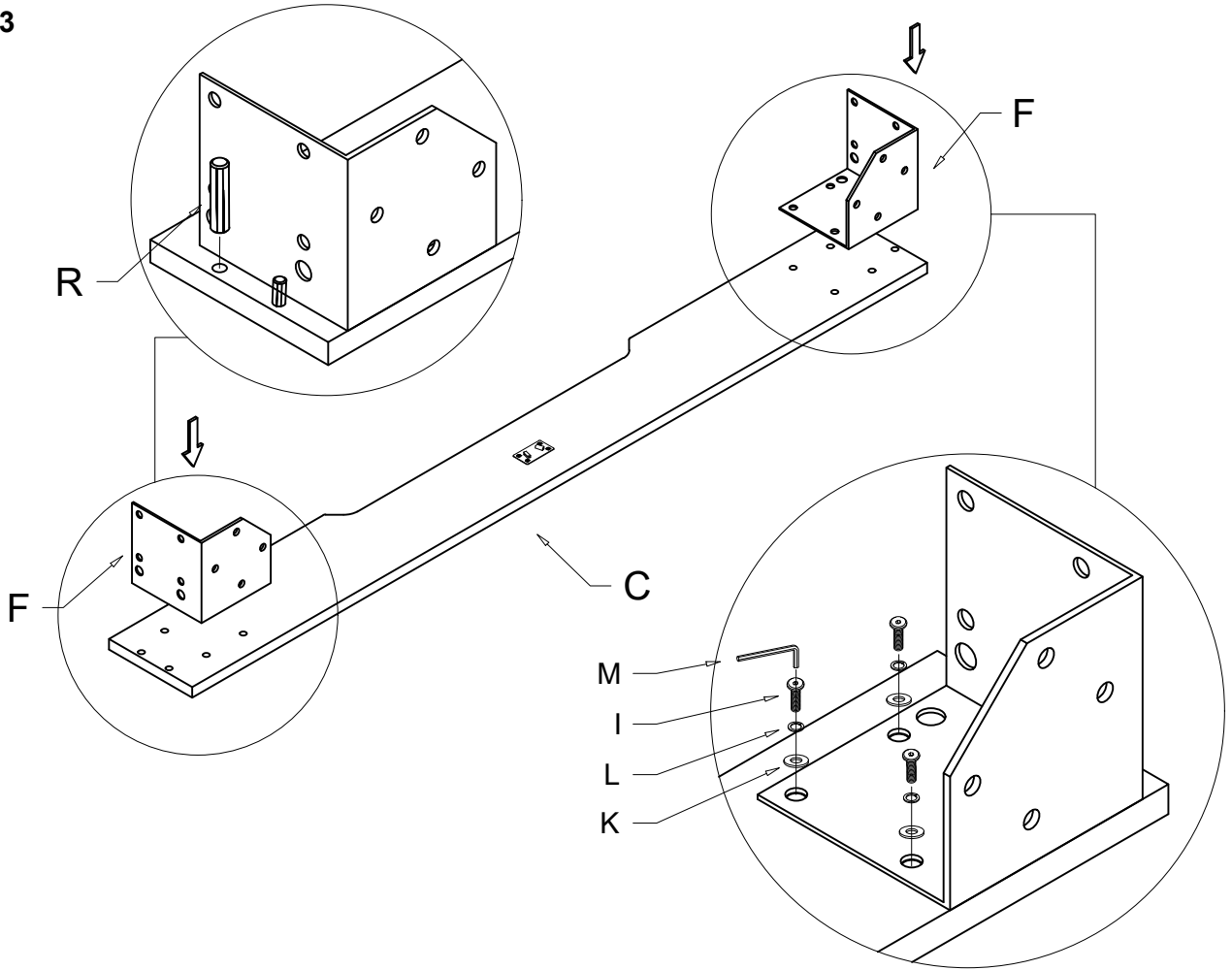

STEP 4

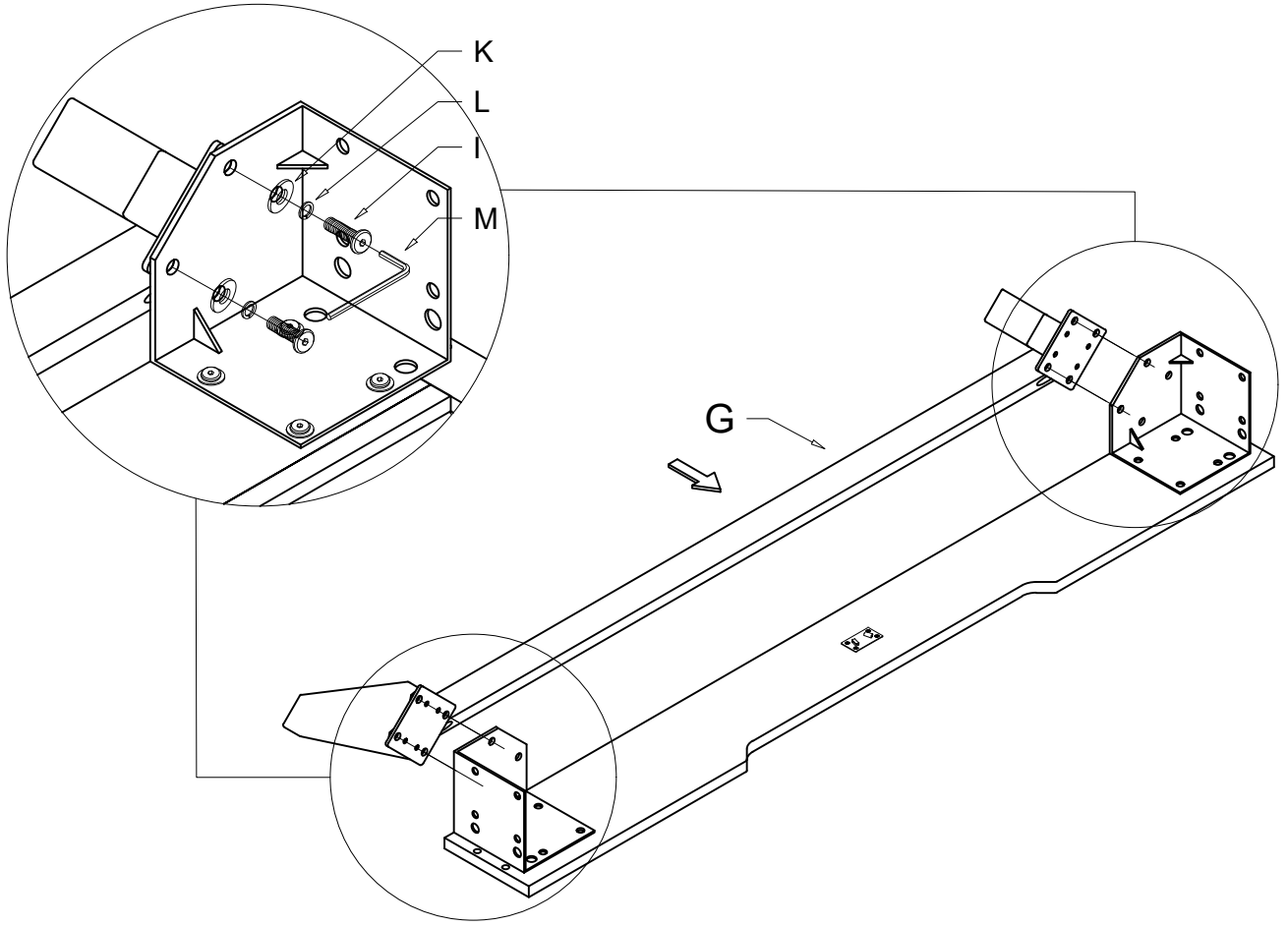

STEP 5

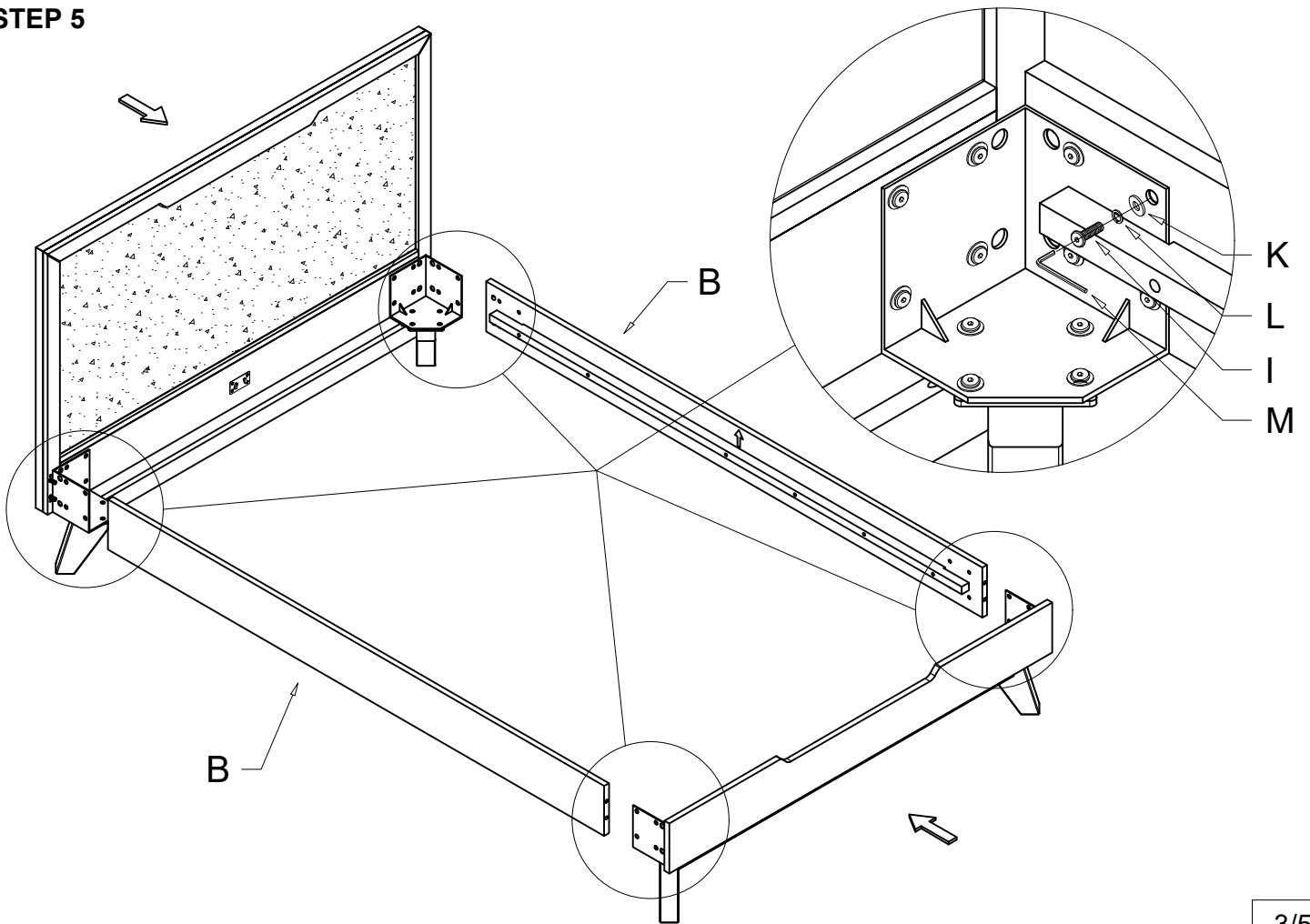

STEP 6

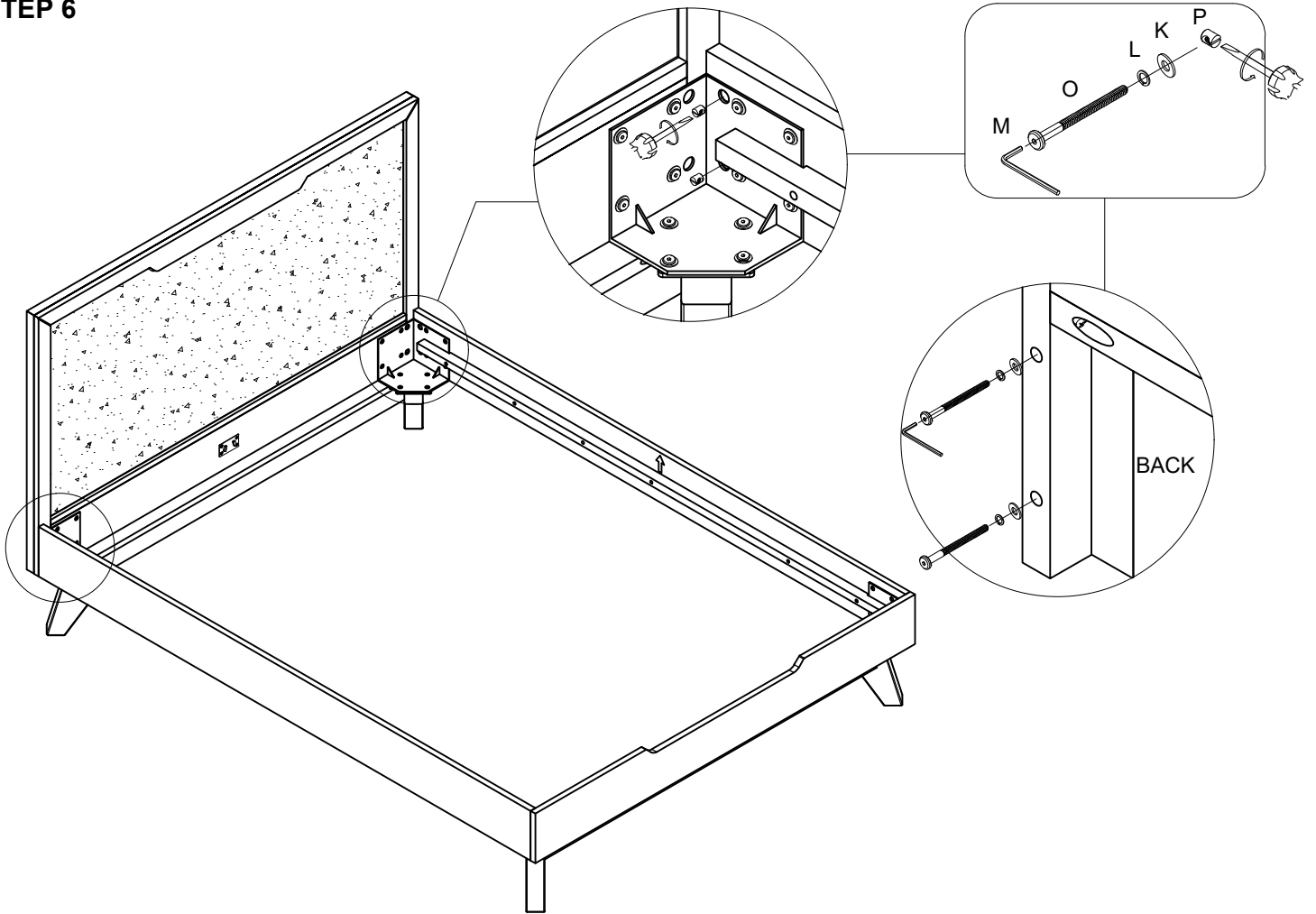

STEP 7

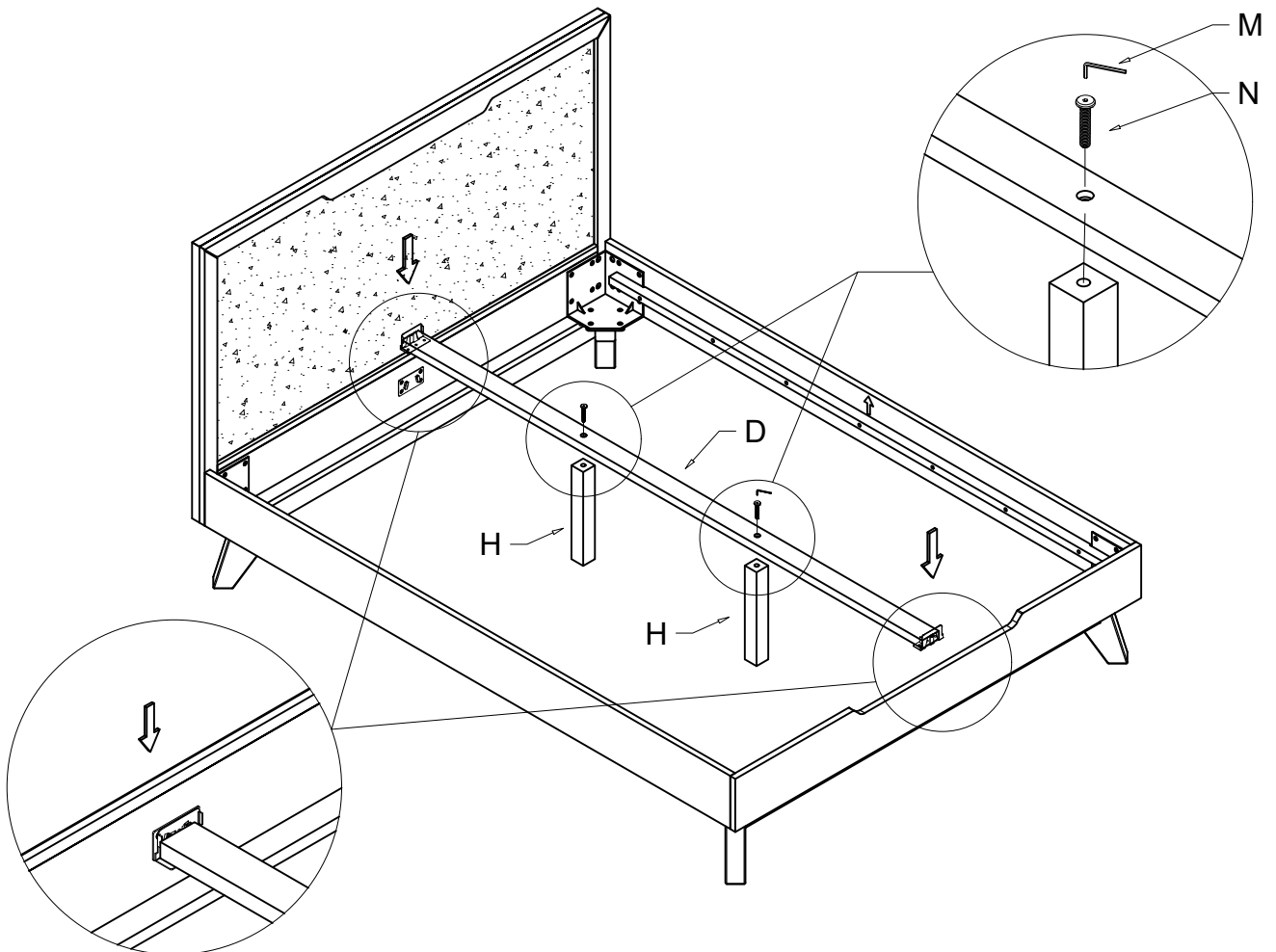

STEP 8

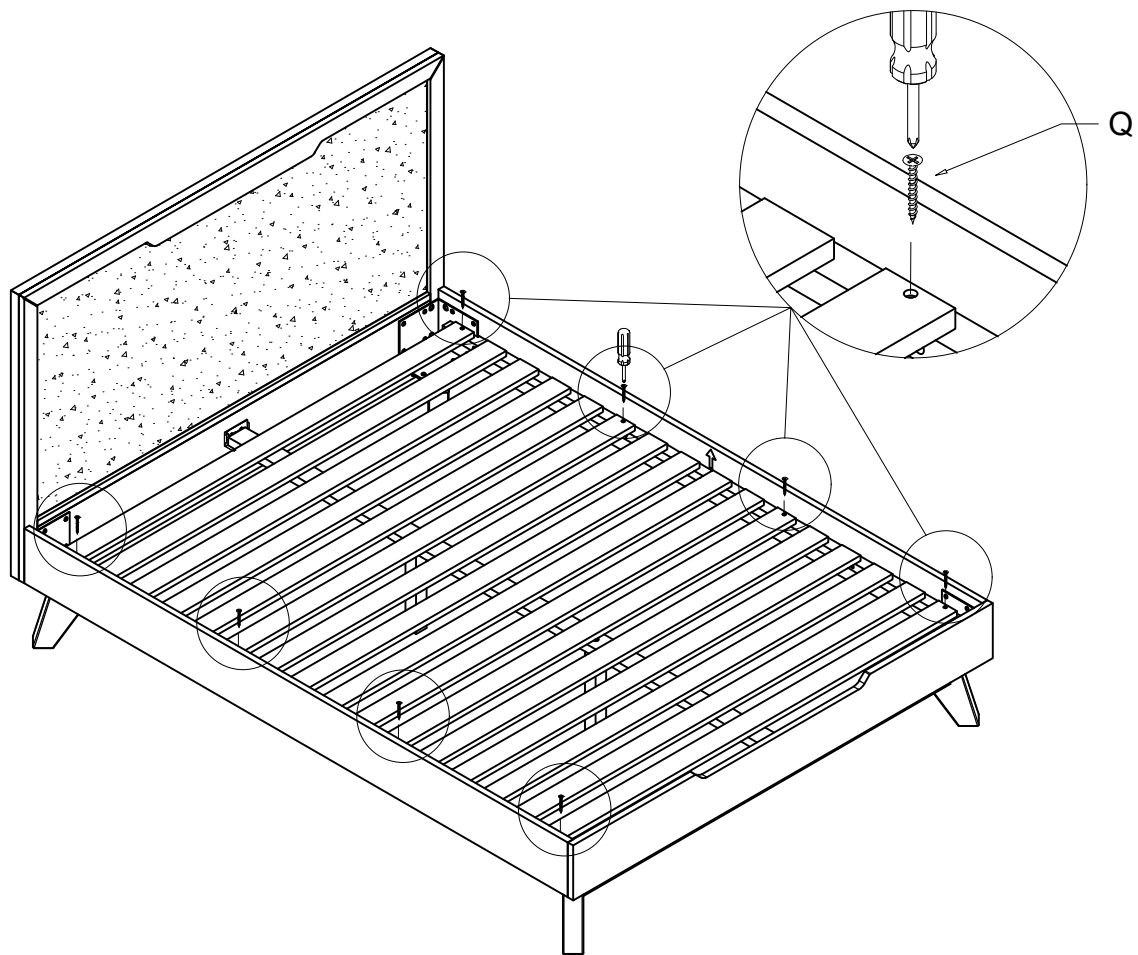

FINISHED

