







## SLIDING-DOOR WINDOW PANE MEDIA CABINET

**PLEASE FIND HARDWARE IN RED POLYBAG BEFORE DISCARDING PACKING MATERIAL.**

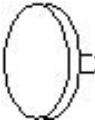
<b>HARDWARE LIST</b>			
<p>(1) CAM-LOCKS <span style="float: right;">8PCS</span></p> 	<p>(5) T-BOLTS <span style="float: right;">4PCS</span></p> 		
<p>(2) COVERS <span style="float: right;">8PCS</span></p> 	<p>(6) SHELF SUPPORTS <span style="float: right;">20PCS</span></p> 		
<p>(3) CAM-BOLTS <span style="float: right;">8PCS</span></p> 	<p>(7) WOOD SCREWS <span style="float: right; color: red;">32PCS</span></p>  <p style="text-align: right;">Ø2.6 x 10mm</p>		
<p>(4) MACHINE SCREWS <span style="float: right;">4PCS</span> Ø1/4" x 2-1/4"</p> 	<p>(8) WOOD DOWELS <span style="float: right;">4PCS</span></p>  <p style="text-align: right;">Ø8 x 30mm</p>		

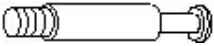
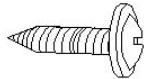
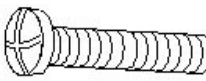
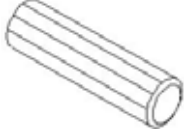
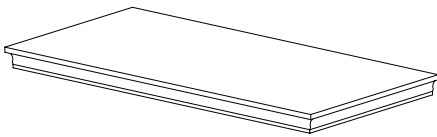
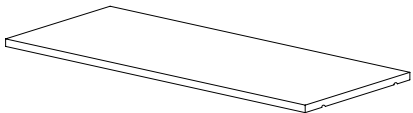
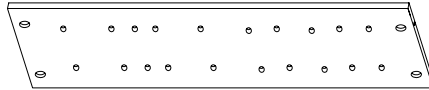
<b>PARTS LIST</b>			
<p>(A) TOP PANEL <span style="float: right;">1PC</span></p> 	<p>(F) ADJUSTABLE SHELVES <span style="float: right;">5PCS</span></p> 		
<p>(B) LEFT SIDE PANEL <span style="float: right;">1PC</span></p> 	<p>(G) RIGHT BACK PANEL <span style="float: right;">1PC</span></p> 		
<p>(C) RIGHT SIDE PANEL <span style="float: right;">1PC</span></p> 	<p>(H) LEFT BACK PANEL <span style="float: right;">1PC</span></p> 		

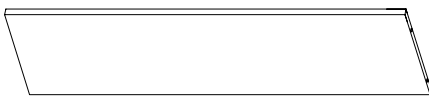
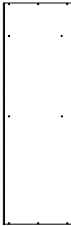
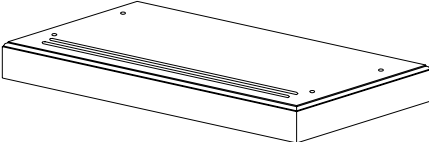
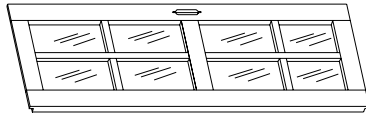
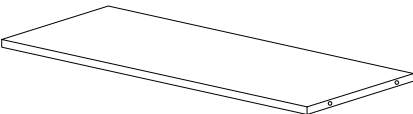
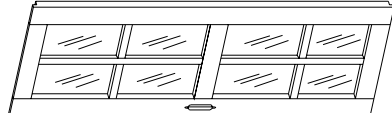
<p>(D) BASE 1PC</p> 	<p>(I) LEFT DOOR 1PC</p> 
<p>(E) FIXED SHELVES 2PCS</p> 	<p>(J) RIGHT DOOR 1PC</p> 

## ASSEMBLY INSTRUCTION

1. SELECT A SMOOTH, SOFT SURFACE TO PREVENT SCRATCHING FINISH. YOU MAY NEED A PHILLIP SCREWDRIVER.
2. PLACE LEFT SIDE PANEL (B) SMOOTH SIDE ON FLAT SURFACE, THEN SCREW 2 CAM-BOLTS (3) INTO PRETHREADED INSERT HOLES ON SIDE PANEL (B) UNTIL STOP. (PLEASE DO NOT OVERTIGHTEN CAM-BOLTS). ALSO PUSH 2 WOOD DOWELS (8) INTO LARGE OPENING HOLES INTO LEFT SIDE PANEL (B). REPEAT SAME PROCEDURE FOR RIGHT SIDE PANEL (C). AS FIGURE 1 SHOWN.
3. NOW, INSERT CAM-BOLTS (3), WOOD DOWELS (8) INTO PREDRILLED HOLES ON ENDS OF FIXED SHELVES (E) AND FIT INTO CORRESPONDING HOLES ON INSIDE OF LEFT AND RIGHT SIDE PANELS (B, C). INSERT CAM-LOCKS (1) INTO BIG HOLES ON INSIDE OF LEFT AND RIGHT SIDE PANELS (B, C) WITH SLOT FOR SCREWDRIVER FACING OUTWARD. ROTATE CAM-LOCKS (1) CLOCKWISE TO SECURE CAM-BOLTS (3). PUSH COVERS (2) INTO CAM-LOCKS (1). AS FIGURE 1 SHOWN.
4. INSERT T-BOLTS (5) INTO PREDRILLED HOLES ON INSIDE OF LEFT AND RIGHT SIDE PANELS (B, C). INSERT MACHINE SCREWS (4) THROUGH PREDRILLED HOLES ON UNDERSIDE OF BASE (D) AND TIGHTEN INTO T-BOLTS (5). PLEASE NOTE THAT IF SCREWS DO NOT TIGHTEN, ROTATE T-BOLTS (5) SO THAT THREADS OF T-BOLTS (5) FACING MACHINE SCREWS (4). AS FIGURE 1 SHOWN.

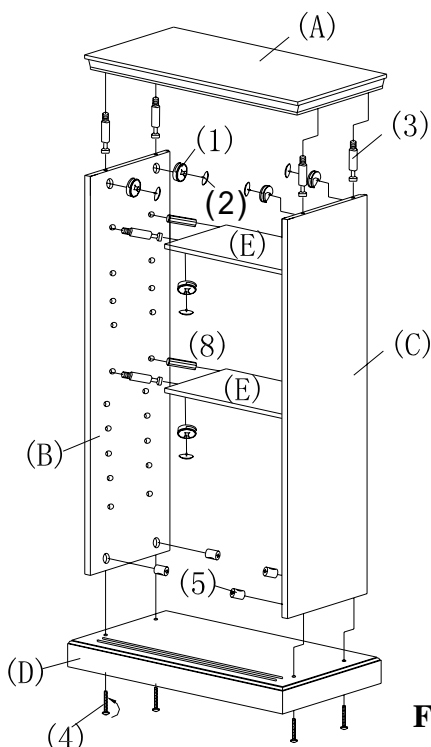

FIGURE 1

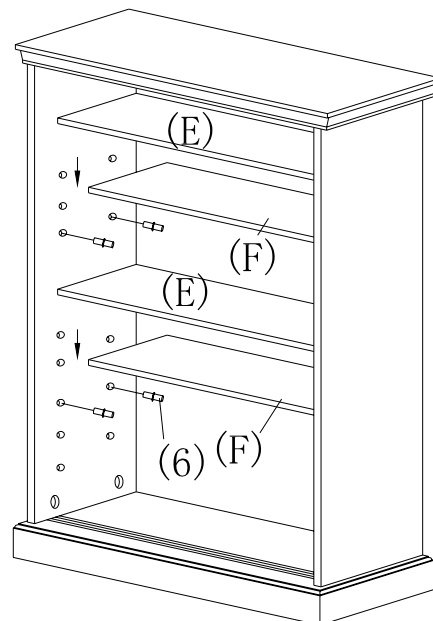
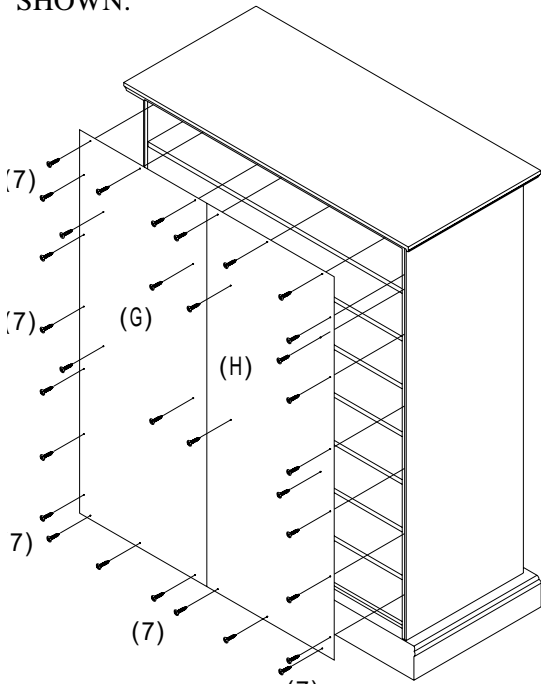
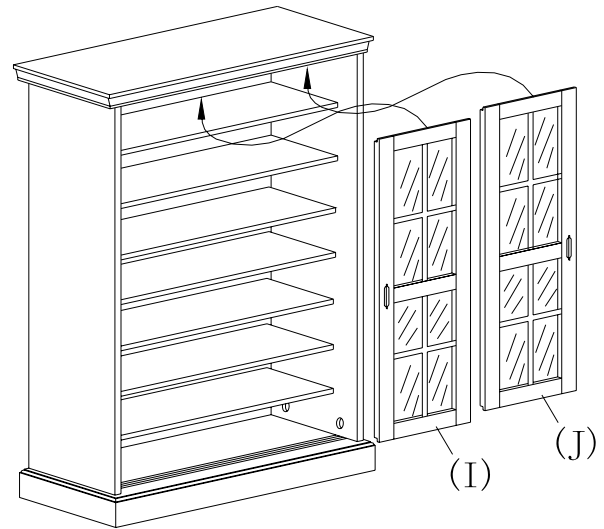

FIGURE 2

5. TIGHTEN CAM-BOLTS (3) INTO THREADED HOLES ON UNDERSIDE OF TOP PANEL (A) AND FIT INTO CORRESPONDING HOLES ON TOP EDGES OF LEFT AND RIGHT SIDE PANELS (B, C). INSERT CAM-LOCKS (1) INTO BIG HOLES ON INSIDE OF LEFT AND RIGHT SIDE PANELS (B, C) WITH SLOT FOR SCREWDRIVER FACING OUTWARD. ROTATE CAM-LOCKS (1) CLOCKWISE TO SECURE CAM-BOLTS (3). PUSH COVERS (2) INTO CAM-LOCKS (1). AS FIGURE 1 SHOWN.
6. FIT SHELF SUPPORTS (6) INTO PREDRILLED HOLES ON INSIDE OF LEFT AND RIGHT SIDE PANELS (B, C). PUT ADJUSTABLE SHELVES (F) ON EACH SHELF SUPPORTS (6) MATCHING THE POSITION OF GROOVES ON ADJUSTABLE SHELVES (F). AS FIGURE 2 SHOWN.
7. ATTACH LEFT AND RIGHT BACK PANELS (H, G) INTO SLOTS OF PARTS (A, B, C, D). INSERT WOOD SCREWS (7) THROUGH PREDRILLED HOLES ON LEFT AND RIGHT BACK PANELS (G, H) AND TIGHTEN INTO REAR EDGES OF PARTS (A, B, C, D). AS FIGURE 3 SHOWN.
8. FIT LEFT AND RIGHT DOORS (I, J) INTO GROOVES ON TOP PANEL AND BASE (A, D). AS FIGURE 4 SHOWN.



(7) **FIGURE 3**



**FIGURE 4**

**SHOWN BACK VIEW FOR ASSEMBLY PURPOSES.**



**READY**

**YOUR NEW SLIDING-DOOR WINDOW PANE MEDIA CABINET IS FINISHED AND READY TO USE.**

**"We will ship parts if available" "This is not a warranty"**

**PARTS REPLACEMENT FORM**

Customer Name

PARTS  
LETTER

PART  
DESCRIPTION

QUANTITY  
NEEDED

Street, City, State, Zip

Phone#

\_\_\_\_\_  
\_\_\_\_\_  
Please indicate where you purchased this item.  
Store/website/catalog

\_\_\_\_\_  
\_\_\_\_\_  
Please indicate color/size/style number